

GLOBAL
EDITION



CRYPTOGRAPHY AND NETWORK SECURITY

Principles and Practice

EIGHTH EDITION

WILLIAM STALLINGS



**CRYPTOGRAPHY AND
NETWORK SECURITY**
PRINCIPLES AND PRACTICE
EIGHTH EDITION
GLOBAL EDITION

William Stallings



Product Management: Gargi Banerjee and Paromita Banerjee
Content Strategy: Shabnam Dohutia, Aurko Mitra, Afshaan Khan, and Sharon Thekkekara
Product Marketing: Wendy Gordon, Ashish Jain, and Ellen Harris
Supplements: Bedasree Das
Digital Studio: Vikram Medepalli and Naina Singh
Rights and Permissions: Rimpay Sharma and Akanksha Bhatti
Cover Art: Gorodenkoff / Shutterstock

Credits and acknowledgments borrowed from other sources and reproduced, with permission, in this textbook appear on the appropriate page within text.

Pearson Education Limited
KAO Two
KAO Park
Hockham Way
Harlow
CM17 9SR
United Kingdom

and Associated Companies throughout the world

Visit us on the World Wide Web at: www.pearsonglobaleditions.com

Please contact <https://support.pearson.com/getsupport/s/contactsupport> with any queries on this content.

© Pearson Education Limited 2023

The right of William Stallings to be identified as the author of this work has been asserted by him in accordance with the Copyright, Designs and Patents Act 1988.

Authorized adaptation from the United States edition, entitled *Cryptography and Network Security: Principles and Practice*, ISBN 978-0-13-670722-6 by William Stallings published by Pearson Education © 2020.

All rights reserved. No part of this publication may be reproduced, stored in a retrieval system, or transmitted in any form or by any means, electronic, mechanical, photocopying, recording or otherwise, without either the prior written permission of the publisher or a license permitting restricted copying in the United Kingdom issued by the Copyright Licensing Agency Ltd, Saffron House, 6–10 Kirby Street, London EC1N 8TS. For information regarding permissions, request forms and the appropriate contacts within the Pearson Education Global Rights & Permissions department, please visit www.pearsoned.com/permissions/.

Attributions of third-party content appear on the appropriate page within the text.

Unless otherwise indicated herein, any third-party trademarks that may appear in this work are the property of their respective owners and any references to third-party trademarks, logos or other trade dress are for demonstrative or descriptive purposes only. Such references are not intended to imply any sponsorship, endorsement, authorization, or promotion of Pearson's products by the owners of such marks, or any relationship between the owner and Pearson Education, Inc. or its affiliates, authors, licensees, or distributors.

This eBook is a standalone product and may or may not include all assets that were part of the print version. It also does not provide access to other Pearson digital products like Revel. The publisher reserves the right to remove any material in this eBook at any time.

ISBN 10: 1-292-43748-0 (print)
ISBN 13: 978-1-292-43748-4 (print)
eBook ISBN 13: 978-1-292-43749-1

British Library Cataloguing-in-Publication Data

A catalogue record for this book is available from the British Library

*For Tricia: never dull, never boring,
the smartest and bravest person I know*

This page is intentionally left blank

CONTENTS

Notation 10

Preface 12

About the Author 19

PART ONE: BACKGROUND 21

Chapter 1 Information and Network Security Concepts 21

- 1.1** Cybersecurity, Information Security, and Network Security 23
- 1.2** The OSI Security Architecture 26
- 1.3** Security Attacks 27
- 1.4** Security Services 30
- 1.5** Security Mechanisms 33
- 1.6** Cryptography 33
- 1.7** Network Security 36
- 1.8** Trust and Trustworthiness 37
- 1.9** Standards 41
- 1.10** Key Terms, Review Questions, and Problems 42

Chapter 2 Introduction to Number Theory 44

- 2.1** Divisibility and the Division Algorithm 45
- 2.2** The Euclidean Algorithm 47
- 2.3** Modular Arithmetic 51
- 2.4** Prime Numbers 59
- 2.5** Fermat's and Euler's Theorems 62
- 2.6** Testing for Primality 66
- 2.7** The Chinese Remainder Theorem 69
- 2.8** Discrete Logarithms 71
- 2.9** Key Terms, Review Questions, and Problems 76
- Appendix 2A The Meaning of Mod 80

PART TWO: SYMMETRIC CIPHERS 83

Chapter 3 Classical Encryption Techniques 83

- 3.1** Symmetric Cipher Model 84
- 3.2** Substitution Techniques 90
- 3.3** Transposition Techniques 105
- 3.4** Key Terms, Review Questions, and Problems 106

Chapter 4 Block Ciphers and the Data Encryption Standard 112

- 4.1** Traditional Block Cipher Structure 113
- 4.2** The Data Encryption Standard 123
- 4.3** A DES Example 125
- 4.4** The Strength of DES 128

6 CONTENTS

- 4.5 Block Cipher Design Principles 129
- 4.6 Key Terms, Review Questions, and Problems 131
- Chapter 5 Finite Fields 135**
 - 5.1 Groups 137
 - 5.2 Rings 139
 - 5.3 Fields 140
 - 5.4 Finite Fields of the Form $GF(p)$ 141
 - 5.5 Polynomial Arithmetic 145
 - 5.6 Finite Fields of the Form $GF(2^n)$ 151
 - 5.7 Key Terms, Review Questions, and Problems 163
- Chapter 6 Advanced Encryption Standard 165**
 - 6.1 Finite Field Arithmetic 167
 - 6.2 AES Structure 168
 - 6.3 AES Transformation Functions 174
 - 6.4 AES Key Expansion 184
 - 6.5 An AES Example 187
 - 6.6 AES Implementation 191
 - 6.7 Key Terms, Review Questions, and Problems 196
 - Appendix 6A Polynomials with Coefficients in $GF(2^8)$ 197
- Chapter 7 Block Cipher Operation 201**
 - 7.1 Multiple Encryption and Triple DES 202
 - 7.2 Electronic CodeBook 207
 - 7.3 Cipher Block Chaining Mode 210
 - 7.4 Cipher Feedback Mode 212
 - 7.5 Output Feedback Mode 214
 - 7.6 Counter Mode 216
 - 7.7 XTS-AES Mode for Block-Oriented Storage Devices 218
 - 7.8 Format-Preserving Encryption 225
 - 7.9 Key Terms, Review Questions, and Problems 239
- Chapter 8 Random Bit Generation and Stream Ciphers 244**
 - 8.1 Principles of Pseudorandom Number Generation 246
 - 8.2 Pseudorandom Number Generators 252
 - 8.3 Pseudorandom Number Generation Using a Block Cipher 255
 - 8.4 Stream Ciphers 260
 - 8.5 RC4 262
 - 8.6 Stream Ciphers Using Feedback Shift Registers 264
 - 8.7 True Random Number Generators 272
 - 8.8 Key Terms, Review Questions, and Problems 281
- PART THREE: ASYMMETRIC CIPHERS 285**
 - Chapter 9 Public-Key Cryptography and RSA 285**
 - 9.1 Principles of Public-Key Cryptosystems 287
 - 9.2 The RSA Algorithm 296
 - 9.3 Key Terms, Review Questions, and Problems 309

Chapter 10 Other Public-Key Cryptosystems 314

- 10.1** Diffie–Hellman Key Exchange 315
- 10.2** Elgamal Cryptographic System 319
- 10.3** Elliptic Curve Arithmetic 322
- 10.4** Elliptic Curve Cryptography 331
- 10.5** Key Terms, Review Questions, and Problems 335

PART FOUR: CRYPTOGRAPHIC DATA INTEGRITY ALGORITHMS 337**Chapter 11 Cryptographic Hash Functions 337**

- 11.1** Applications of Cryptographic Hash Functions 339
- 11.2** Two Simple Hash Functions 344
- 11.3** Requirements and Security 346
- 11.4** Secure Hash Algorithm (SHA) 352
- 11.5** SHA-3 362
- 11.6** Key Terms, Review Questions, and Problems 374

Chapter 12 Message Authentication Codes 378

- 12.1** Message Authentication Requirements 379
- 12.2** Message Authentication Functions 380
- 12.3** Requirements for Message Authentication Codes 388
- 12.4** Security of MACs 390
- 12.5** MACs Based on Hash Functions: HMAC 391
- 12.6** MACs Based on Block Ciphers: DAA and CMAC 396
- 12.7** Authenticated Encryption: CCM and GCM 399
- 12.8** Key Wrapping 405
- 12.9** Pseudorandom Number Generation Using Hash Functions and MACs 410
- 12.10** Key Terms, Review Questions, and Problems 413

Chapter 13 Digital Signatures 416

- 13.1** Digital Signatures 418
- 13.2** ElGamal Digital Signature Scheme 421
- 13.3** Schnorr Digital Signature Scheme 422
- 13.4** NIST Digital Signature Algorithm 423
- 13.5** Elliptic Curve Digital Signature Algorithm 427
- 13.6** RSA-PSS Digital Signature Algorithm 430
- 13.7** Key Terms, Review Questions, and Problems 435

Chapter 14 Lightweight Cryptography and Post-Quantum Cryptography 438

- 14.1** Lightweight Cryptography Concepts 439
- 14.2** Lightweight Cryptographic Algorithms 448
- 14.3** Post-Quantum Cryptography Concepts 456
- 14.4** Post-Quantum Cryptographic Algorithms 462
- 14.5** Key Terms and Review Questions 472

PART FIVE: MUTUAL TRUST 473**Chapter 15 Cryptographic Key Management and Distribution 473**

- 15.1** Symmetric Key Distribution Using Symmetric Encryption 474
- 15.2** Symmetric Key Distribution Using Asymmetric Encryption 478

8 CONTENTS

- 15.3 Distribution of Public Keys 481
- 15.4 X.509 Certificates 485
- 15.5 Public-Key Infrastructure 494
- 15.6 Key Terms, Review Questions, and Problems 496
- Chapter 16 User Authentication 500**
 - 16.1 Remote User-Authentication Principles 501
 - 16.2 Remote User-Authentication Using Symmetric Encryption 507
 - 16.3 Kerberos 510
 - 16.4 Remote User-Authentication Using Asymmetric Encryption 524
 - 16.5 Federated Identity Management 526
 - 16.6 Key Terms, Review Questions, and Problems 530
- PART SIX: NETWORK AND INTERNET SECURITY 533**
- Chapter 17 Transport-Level Security 533**
 - 17.1 Web Security Considerations 534
 - 17.2 Transport Layer Security 536
 - 17.3 HTTPS 551
 - 17.4 Secure Shell (SSH) 553
 - 17.5 Review Questions and Problems 564
- Chapter 18 Wireless Network Security 566**
 - 18.1 Wireless Security 567
 - 18.2 Mobile Device Security 570
 - 18.3 IEEE 802.11 Wireless Lan Overview 574
 - 18.4 IEEE 802.11i Wireless Lan Security 580
 - 18.5 Key Terms, Review Questions, and Problems 595
- Chapter 19 Electronic Mail Security 597**
 - 19.1 Internet Mail Architecture 599
 - 19.2 Email Formats 601
 - 19.3 Email Threats and Comprehensive Email Security 607
 - 19.4 S/MIME 609
 - 19.5 DNSSEC 619
 - 19.6 DNS-Based Authentication of Named Entities 622
 - 19.7 Sender Policy Framework 625
 - 19.8 DomainKeys Identified Mail 628
 - 19.9 Domain-Based Message Authentication, Reporting, and Conformance 634
 - 19.10 Key Terms, Review Questions, and Problems 639
- Chapter 20 IP Security 640**
 - 20.1 IP Security Overview 641
 - 20.2 IP Security Policy 643
 - 20.3 Encapsulating Security Payload 648
 - 20.4 Combining Security Associations 656
 - 20.5 Internet Key Exchange 659
 - 20.6 Key Terms, Review Questions, and Problems 667
- Chapter 21 Network Endpoint Security 669**
 - 21.1 Firewalls 670
 - 21.2 Intrusion Detection Systems 680

21.3	Malicious Software	685
21.4	Distributed Denial of Service Attacks	688
21.5	Key Terms, Review Questions, and Problems	693
Chapter 22 Cloud Security 698		
22.1	Cloud Computing	699
22.2	Cloud Security Concepts	709
22.3	Cloud Security Risks and Countermeasures	711
22.4	Cloud Security as a Service	719
22.5	An Open-Source Cloud Security Module	722
22.6	Key Terms and Review Questions	723
Chapter 23 Internet of Things (IoT) Security 725		
23.1	The Internet of Things	726
23.2	IoT Security Concepts and Objectives	731
23.3	An Open-Source IoT Security Module	737
23.4	Key Terms and Review Questions	742
Appendix A Basic Concepts from Linear Algebra 744		
A.1	Operations on Vectors and Matrices	745
A.2	Linear Algebra Operations over \mathbb{Z}_n	748
Appendix B Measures of Secrecy and Security 751		
B.1	Conditional Probability	752
B.2	Perfect Secrecy	752
B.3	Information and Entropy	756
B.4	Entropy and Secrecy	762
B.5	Min-Entropy	763
Appendix C Data Encryption Standard 766		
Appendix D Simplified AES 774		
D.1	Overview	775
D.2	S-AES Encryption and Decryption	777
D.3	Key Expansion	780
D.4	The S-Box	781
D.5	S-AES Structure	781
ANNEX D.1	Arithmetic in $\text{GF}(2^4)$	783
ANNEX D.2	The Mix Column Function	784
Appendix E Mathematical Basis of the Birthday Attack 786		
E.1	Related Problem	787
E.2	The Birthday Paradox	787
E.3	Useful Inequality	789
E.4	The General Case of Duplications	790
E.5	Overlap Between Two Sets	791
Glossary 793		
References 804		
Index 815		
Acronyms 832		

NOTATION

Symbol	Expression	Meaning
D, K	$D(K, Y)$	Symmetric decryption of ciphertext Y using secret key K
D, PR_a	$D(PR_a, Y)$	Asymmetric decryption of ciphertext Y using A's private key PR_a
D, PU_a	$D(PU_a, Y)$	Asymmetric decryption of ciphertext Y using A's public key PU_a
E, K	$E(K, X)$	Symmetric encryption of plaintext X using secret key K
E, PR_a	$E(PR_a, X)$	Asymmetric encryption of plaintext X using A's private key PR_a
E, PU_a	$E(PU_a, X)$	Asymmetric encryption of plaintext X using A's public key PU_a
K		Secret key
PR_a		Private key of user A
PU_a		Public key of user A
MAC, K	$MAC(K, X)$	Message authentication code of message X using secret key K
$GF(p)$		The finite field of order p , where p is prime. The field is defined as the set Z_p together with the arithmetic operations modulo p .
$GF(2^n)$		The finite field of order 2^n
Z_n		Set of nonnegative integers less than n
gcd	$\text{gcd}(i, j)$	Greatest common divisor; the largest positive integer that divides both i and j with no remainder on division.
mod	$a \bmod m$	Remainder after division of a by m
mod, \equiv	$a \equiv b \pmod{m}$	$a \bmod m = b \bmod m$
mod, $\not\equiv$	$a \not\equiv b \pmod{m}$	$a \bmod m \neq b \bmod m$
dlog	$\text{dlog}_{a,p}(b)$	Discrete logarithm of the number b for the base $a \pmod{p}$
φ	$\phi(n)$	The number of positive integers less than n and relatively prime to n . This is Euler's totient function.
Σ	$\sum_{i=1}^n a_i$	$a_1 + a_2 + \dots + a_n$
Π	$\prod_{i=1}^n a_i$	$a_1 \times a_2 \times \dots \times a_n$

Symbol	Expression	Meaning
	$i j$	i divides j , which means that there is no remainder when j is divided by i
,	$ a $	Absolute value of a
	$x y$	x concatenated with y
\approx	$x \approx y$	x is approximately equal to y
\oplus	$x \oplus y$	Exclusive-OR of x and y for single-bit variables; Bitwise exclusive-OR of x and y for multiple-bit variables
[,]	$\lfloor x \rfloor$	The largest integer less than or equal to x
\in	$x \in S$	The element x is contained in the set S .
\longleftrightarrow	$A \longleftrightarrow (a_1, a_2, \dots, a_k)$	The integer A corresponds to the sequence of integers (a_1, a_2, \dots, a_k)

PREFACE

What's New in The Eighth Edition	12
Objectives	13
Support of ACM/IEEE Computer Science Curricula 2013	13
Plan of The Text	14
Instructor Support Materials	14
Projects and Other Student Exercises	15
The Sage Computer Algebra System	16
Acknowledgments	17
Acknowledgments for the Global Edition	18

WHAT'S NEW IN THE EIGHTH EDITION

Since the seventh edition of this book was published, the field has seen continued innovations and improvements. In this new edition, I try to capture these changes while maintaining a broad and comprehensive coverage of the entire field. To begin this process of revision, the seventh edition of this book was extensively reviewed by a number of professors who teach the subject and by professionals working in the field. The result is that, in many places, the narrative has been clarified and tightened, and illustrations have been improved.

Beyond these refinements to improve pedagogy and user-friendliness, there have been substantive changes throughout the book. Roughly the same chapter organization has been retained, but much of the material has been revised and new material has been added. The most noteworthy changes are as follows:

- **Trust and trustworthiness:** Chapter 1 includes a new section describing these two concepts, which are key concepts in computer and network security.
- **Stream ciphers:** With the growing importance of stream ciphers, the treatment of stream ciphers has been significantly expanded. There is a new section on stream ciphers based on linear feedback shift registers (LFSRs), and several examples of contemporary stream ciphers are provided.
- **Lightweight cryptography:** The Internet of Things and other small embedded systems require new approaches to cryptography to accommodate the low power requirements, minimum memory, and limited processing power of IoT devices. Two new sections cover this rapidly emerging topic.
- **Post-quantum cryptography:** In anticipation of the potential threat posed by quantum computers, there has been considerable research and development of cryptographic algorithms that are resistant to the threat. Two new sections cover this rapidly emerging topic.

- **Cloud security:** The discussion of cloud security has been expanded, and an entire chapter is devoted to this topic in the new edition.
- **IoT network security:** Similarly, IoT networks have resulted in new requirements for network security protocols, which are covered.

OBJECTIVES

It is the purpose of this book to provide a practical survey of both the principles and practice of cryptography and network security. In the first part of the book, the basic issues to be addressed by a network security capability are explored by providing a tutorial and survey of cryptography and network security technology. The latter part of the book deals with the practice of network security: practical applications that have been implemented and are in use to provide network security.

The subject, and therefore this book, draws on a variety of disciplines. In particular, it is impossible to appreciate the significance of some of the techniques discussed in this book without a basic understanding of number theory and some results from probability theory. Nevertheless, an attempt has been made to make the book self-contained. The book not only presents the basic mathematical results that are needed but provides the reader with an intuitive understanding of those results. Such background material is introduced as needed. This approach helps to motivate the material that is introduced, and the author considers this preferable to simply presenting all of the mathematical material in a lump at the beginning of the book.

SUPPORT OF ACM/IEEE COMPUTER SCIENCE CURRICULA 2013

The book is intended for both academic and professional audiences. As a textbook, it is intended as a one-semester undergraduate course in cryptography and network security for computer science, computer engineering, and electrical engineering majors. This edition supports the recommendations of the ACM/IEEE Computer Science Curricula 2013 (CS2013). CS2013 adds Information Assurance and Security (IAS) to the curriculum recommendation as one of the Knowledge Areas in the Computer Science Body of Knowledge. The document states that IAS is now part of the curriculum recommendation because of the critical role of IAS in computer science education. CS2013 divides all course work into three categories: Core-Tier 1 (all topics should be included in the curriculum), Core-Tier-2 (all or almost all topics should be included), and elective (desirable to provide breadth and depth). In the IAS area, CS2013 recommends topics in Fundamental Concepts and Network Security in Tier 1 and Tier 2, and Cryptography topics as elective. This text covers virtually all of the topics listed by CS2013 in these three categories.

The book also serves as a basic reference volume and is suitable for self-study.

PLAN OF THE TEXT

The book is divided into six parts.

- Background
- Symmetric Ciphers
- Asymmetric Ciphers
- Cryptographic Data Integrity Algorithms
- Mutual Trust
- Network and Internet Security

The book includes a number of pedagogic features, including the use of the computer algebra system Sage and numerous figures and tables to clarify the discussions. Most chapters include a list of key words, review questions, suggestions for further reading, and recommended Web sites. Most chapters also include homework problems. The book also includes an extensive glossary, a list of frequently used acronyms, and a bibliography. In addition, a test bank is available to instructors.

INSTRUCTOR SUPPORT MATERIALS

The major goal of this text is to make it as effective a teaching tool for this exciting and fast-moving subject as possible. This goal is reflected both in the structure of the book and in the supporting material. The text is accompanied by the following supplementary material that will aid the instructor:

- **Solutions manual:** Solutions to all end-of-chapter Review Questions and Problems.
- **Projects manual:** Suggested project assignments for all of the project categories listed below.
- **PowerPoint slides:** A set of slides covering all chapters, suitable for use in lecturing.
- **PDF files:** Reproductions of all figures and tables from the book.
- **Test bank:** A chapter-by-chapter set of questions with a separate file of answers.
- **Supplemental homework problems and solutions:** To aid the student in understanding the material, a separate set of homework problems with solutions are available.

All of these support materials are available at the **Instructor Resource Center (IRC)** for this textbook, which can be reached through the publisher's Web site www.pearsonglobaleditions.com.

PROJECTS AND OTHER STUDENT EXERCISES

For many instructors, an important component of a cryptography or network security course is a project or set of projects by which the student gets hands-on experience to reinforce concepts from the text. This book provides an unparalleled degree of support, including a project's component in the course. The IRC not only includes guidance on how to assign and structure the projects, but also includes a set of project assignments that covers a broad range of topics from the text:

- **Sage projects:** Described in the next section.
- **Hacking project:** Exercise designed to illuminate the key issues in intrusion detection and prevention.
- **Block cipher projects:** A lab that explores the operation of the AES encryption algorithm by tracing its execution, computing one round by hand, and then exploring the various block cipher modes of use. The lab also covers DES. In both cases, an online Java applet is used (or can be downloaded) to execute AES or DES.
- **Lab exercises:** A series of projects that involve programming and experimenting with concepts from the book.
- **Research projects:** A series of research assignments that instruct the student to research a particular topic on the Internet and write a report.
- **Programming projects:** A series of programming projects that cover a broad range of topics and that can be implemented in any suitable language on any platform.
- **Practical security assessments:** A set of exercises to examine current infrastructure and practices of an existing organization.
- **Firewall projects:** A portable network firewall visualization simulator, together with exercises for teaching the fundamentals of firewalls.
- **Case studies:** A set of real-world case studies, including learning objectives, case description, and a series of case discussion questions.
- **Writing assignments:** A set of suggested writing assignments, organized by chapter.
- **Reading/report assignments:** A list of papers in the literature—one for each chapter—that can be assigned for the student to read and then write a short report.
- **Discussion topics:** These topics can be used in a classroom, chat room, or message board environment to explore certain areas in greater depth and to foster student collaboration.

This diverse set of projects and other student exercises enables the instructor to use the book as one component in a rich and varied learning experience and to tailor a course plan to meet the specific needs of the instructor and students.

THE SAGE COMPUTER ALGEBRA SYSTEM

One of the most important features of this book is the use of Sage for cryptographic examples and homework assignments. Sage is an open-source, multiplatform, freeware package that implements a very powerful, flexible, and easily learned mathematics and computer algebra system. Unlike competing systems (such as Mathematica, Maple, and MATLAB), there are no licensing agreements or fees involved. Thus, Sage can be made available on computers and networks at school, and students can individually download the software to their own personal computers for use at home. Another advantage of using Sage is that students learn a powerful, flexible tool that can be used for virtually any mathematical application, not just cryptography.

The use of Sage can make a significant difference to the teaching of the mathematics of cryptographic algorithms. Two documents available at the IRC support student use of Sage. The first document provides a large number of examples of the use of Sage covering many cryptographic concepts. The second document provides exercises in each of these topic areas to enable the student to gain hands-on experience with cryptographic algorithms. This appendix is available to instructors at the IRC for this book. It also includes a section on how to download and get started with Sage, a section on programming with Sage, and exercises that can be assigned to students in the following categories:

- **Chapter 2—Introduction to Number Theory:** Euclidean and extended Euclidean algorithms, polynomial arithmetic, $GF(2^4)$, Euler's Totient function, Miller Rabin, factoring, modular exponentiation, discrete logarithm, and Chinese remainder theorem.
- **Chapter 3—Classical Encryption Techniques:** Affine ciphers and the Hill cipher.
- **Chapter 4—Block Ciphers and the Data Encryption Standard:** Exercises based on SDES.
- **Chapter 6—Advanced Encryption Standard:** Exercises based on SAES.
- **Chapter 8—Random Bit Generation and Stream Ciphers:** Blum Blum Shub, linear congruential generator, and ANSI X9.17 PRNG.
- **Chapter 9—Public-Key Cryptography and RSA:** RSA encrypt/decrypt and signing.
- **Chapter 10—Other Public-Key Cryptosystems:** Diffie-Hellman, elliptic curve.
- **Chapter 11—Cryptographic Hash Functions:** Number-theoretic hash function.
- **Chapter 13—Digital Signatures:** DSA.

ACKNOWLEDGMENTS

This new edition has benefited from review by a number of people who gave generously of their time and expertise. The following people reviewed all or a large part of the manuscript: Hossein Beyzavi (Marymount University), Donald F. Costello (University of Nebraska Lincoln), James Haralambides (Barry University), Tenette Prevatte (Fayetteville Technical Community College), Anand Seetharam (California State University Monterey Bay), Tenette Prevatte (Fayetteville Technical Community College), Marius C. Silaghi (Florida Institute of Technology), Shambhu Upadhyaya (University at Buffalo), Rose Volynskiy (Howard Community College), Katherine Winters (University of Tennessee at Chattanooga), Zhengping Wu (California State University at San Bernardino), Liangliang Xiao (Frostburg State University), Seong-Moo (Sam) Yoo (The University of Alabama in Huntsville), and Hong Zhang (Armstrong State University).

Thanks also to the people who provided detailed technical reviews of one or more chapters: Amaury Behague, Olivier Blazy, Dhananjoy Dey, Matt Frost, Markus Koskinen, Manuel J. Martínez, Veena Nayak, Pritesh Prajapati, Bernard Roussely, Jim Sweeney, Jim Tunnicliffe, and Jose Rivas Vidal.

In addition, I was fortunate to have reviews of individual topics by “subject-area gurus,” including Jesse Walker of Intel (Intel’s Digital Random Number Generator), Russ Housley of Vigil Security (key wrapping), Joan Daemen (AES), Edward F. Schaefer of Santa Clara University (Simplified AES), Tim Mathews, formerly of RSA Laboratories (S/MIME), Alfred Menezes of the University of Waterloo (elliptic curve cryptography), William Sutton, Editor/Publisher of *The Cryptogram* (classical encryption), Avi Rubin of Johns Hopkins University (number theory), Michael Markowitz of Information Security Corporation (SHA and DSS), Don Davis of IBM Internet Security Systems (Kerberos), Steve Kent of BBN Technologies (X.509), and Phil Zimmerman (PGP).

Nikhil Bhargava (IIT Delhi) developed the set of online homework problems and solutions. Dan Shumow of Microsoft and the University of Washington developed all of the Sage examples and assignments. Professor Sreekanth Malladi of Dakota State University developed the hacking exercises. Lawrie Brown of the Australian Defence Force Academy provided the AES/DES block cipher projects and the security assessment assignments.

Sanjay Rao and Ruben Torres of Purdue University developed the laboratory exercises that appear in the IRC. The following people contributed project assignments that appear in the instructor’s supplement: Henning Schulzrinne (Columbia University); Cetin Kaya Koc (Oregon State University); and David Balenson (Trusted Information Systems and George Washington University). Kim McLaughlin developed the test bank.

Finally, I thank the many people responsible for the publication of this book, all of whom did their usual excellent job. This includes the staff at Pearson, particularly my editor Tracy Johnson and production manager Carole Snyder. Thanks also to the marketing and sales staffs at Pearson, without whose efforts this book would not be in front of you.

ACKNOWLEDGMENTS FOR THE GLOBAL EDITION

Pearson would like to acknowledge and thank the following for their work on the Global Edition.

Contributors

Issteffany Araujo (London Metropolitan University)

George Petrides

Somitra Sanadhya (IIT Jodhpur)

Wen-Nung Tsai (National Yang Ming Chiao Tung University)

Reviewers

Avik Chakraborti (University of Exeter)

Basel Halak (University of Southampton)

Erik Mårtensson (University of Bergen)

Vincent Rijmen (KU Leuven)

ABOUT THE AUTHOR

Dr. William Stallings has authored 18 textbooks, and, counting revised editions, over 70 books on computer security, computer networking, and computer architecture. His writings have appeared in numerous ACM and IEEE publications, including the *Proceedings of the IEEE* and *ACM Computing Reviews*. He has received the award 13 times for the best Computer Science textbook of the year from the Text and Academic Authors Association.

In over 30 years in the field, he has been a technical contributor, technical manager, and an executive with several high-technology firms. He has designed and implemented both TCP/IP-based and OSI-based protocol suites on a variety of computers and operating systems, ranging from microcomputers to mainframes. Currently he is an independent consultant whose clients have included computer and networking manufacturers and customers, software development firms, and leading-edge government research institutions.

He created and maintains the **Computer Science Student Resource Site** at <http://www.computer-sciencestudent.com/>. This site provides documents and links on a variety of subjects of general interest to computer science students and professionals. He is a member of the editorial board of *Cryptologia*, a scholarly journal devoted to all aspects of cryptology.

Dr. Stallings holds a PhD from the Massachusetts Institute of Technology in Computer Science and a B.S. from Notre Dame in electrical engineering.

This page is intentionally left blank

INFORMATION AND NETWORK SECURITY CONCEPTS

1.1 Cybersecurity, Information Security, and Network Security

Security Objectives

The Challenges of Information Security

1.2 The OSI Security Architecture

1.3 Security Attacks

Passive Attacks

Active Attacks

1.4 Security Services

Authentication

Access Control

Data Confidentiality

Data Integrity

Nonrepudiation

Availability Service

1.5 Security Mechanisms

1.6 Cryptography

Keyless Algorithms

Single-Key Algorithms

Two-Key Algorithms

1.7 Network Security

Communications Security

Device Security

1.8 Trust and Trustworthiness

A Trust Model

The Trust Model and Information Security

Establishing Trust Relationships

1.9 Standards

1.10 Key Terms, Review Questions, and Problems

LEARNING OBJECTIVES

After studying this chapter, you should be able to:

- ◆ Describe the key security requirements of confidentiality, integrity, and availability.
- ◆ Discuss the types of security threats and attacks that must be dealt with and give examples of the types of threats and attacks that apply to different categories of computer and network assets.
- ◆ Provide an overview of keyless, single-key, and two-key cryptographic algorithms.
- ◆ Provide an overview of the main areas of network security.
- ◆ Describe a trust model for information security.
- ◆ List and briefly describe key organizations involved in cryptography standards.

This book focuses on two broad areas: cryptography and network security. This overview chapter first looks at some of the fundamental principles of security, encompassing both information security and network security. These include the concepts of security attacks, security services, and security mechanisms. Next, the chapter introduces the two areas of cryptography and network security. Finally, the concepts of trust and trustworthiness are examined.

1.1 CYBERSECURITY, INFORMATION SECURITY, AND NETWORK SECURITY

It would be useful to start this chapter with a definition of the terms cybersecurity, information security, and network security. A reasonably comprehensive definition of cybersecurity is:

Cybersecurity is the protection of information that is stored, transmitted, and processed in a networked system of computers, other digital devices, and network devices and transmission lines, including the Internet. Protection encompasses confidentiality, integrity, availability, authenticity, and accountability. Methods of protection include organizational policies and procedures, as well as technical means such as encryption and secure communications protocols.

As subsets of cybersecurity, we can define the following:

- **Information security:** This term refers to preservation of confidentiality, integrity, and availability of information. In addition, other properties, such as authenticity, accountability, nonrepudiation, and reliability can also be involved.
- **Network security:** This term refers to protection of networks and their service from unauthorized modification, destruction, or disclosure, and provision of assurance that the network performs its critical functions correctly and there are no harmful side effects.

Cybersecurity encompasses information security, with respect to electronic information, and network security. Information security also is concerned with physical (e.g., paper-based) information. However, in practice, the terms cybersecurity and information security are often used interchangeably.

Security Objectives

The cybersecurity definition introduces three key objectives that are at the heart of information and network security:

- **Confidentiality:** This term covers two related concepts:
 - **Data¹ confidentiality:** Assures that private or confidential information is not made available or disclosed to unauthorized individuals.

¹We can define information as communication or representation of knowledge such as facts, data, or opinions in any medium or form, including textual, numerical, graphic, cartographic, narrative, or audiovisual; and data as information with a specific representation that can be produced, processed, or stored by a computer. Security literature typically does not make much of a distinction, nor does this book.

- **Privacy:** Assures that individuals control or influence what information related to them may be collected and stored and by whom and to whom that information may be disclosed.
- **Integrity:** This term covers two related concepts:
 - **Data integrity:** Assures that data (both stored and in transmitted packets) and programs are changed only in a specified and authorized manner. This concept also encompasses **data authenticity**, which means that a digital object is indeed what it claims to be or what it is claimed to be, and nonrepudiation, which is assurance that the sender of information is provided with proof of delivery and the recipient is provided with proof of the sender's identity, so neither can later deny having processed the information.
 - **System integrity:** Assures that a system performs its intended function in an unimpaired manner, free from deliberate or inadvertent unauthorized manipulation of the system.
- **Availability:** Assures that systems work promptly and service is not denied to authorized users.

These three concepts form what is often referred to as the **CIA triad**. The three concepts embody the fundamental security objectives for both data and for information and computing services. For example, the NIST standard FIPS 199 (*Standards for Security Categorization of Federal Information and Information Systems*) lists confidentiality, integrity, and availability as the three security objectives for information and for information systems. FIPS 199 provides a useful characterization of these three objectives in terms of requirements and the definition of a loss of security in each category:

- **Confidentiality:** Preserving authorized restrictions on information access and disclosure, including means for protecting personal privacy and proprietary information. A loss of confidentiality is the unauthorized disclosure of information.
- **Integrity:** Guarding against improper information modification or destruction, including ensuring information nonrepudiation and authenticity. A loss of integrity is the unauthorized modification or destruction of information.
- **Availability:** Ensuring timely and reliable access to and use of information. A loss of availability is the disruption of access to or use of information or an information system.

Although the use of the CIA triad to define security objectives is well established, some in the security field feel that additional concepts are needed to present a complete picture (Figure 1.1). Two of the most commonly mentioned are as follows:

- **Authenticity:** The property of being genuine and being able to be verified and trusted; confidence in the validity of a transmission, a message, or message originator. This means verifying that users are who they say they are and that each input arriving at the system came from a trusted source.

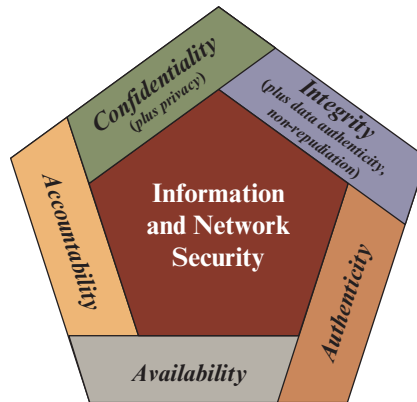

Figure 1.1 Essential Information and Network Security Objectives

- **Accountability:** The security goal that generates the requirement for actions of an entity to be traced uniquely to that entity. This supports nonrepudiation, deterrence, fault isolation, intrusion detection and prevention, and after-action recovery and legal action. Because truly secure systems are not yet an achievable goal, we must be able to trace a security breach to a responsible party. Systems must keep records of their activities to permit later forensic analysis to trace security breaches or to aid in transaction disputes.

The Challenges of Information Security

Information and network security are both fascinating and complex. Some of the reasons follow:

1. Security is not as simple as it might first appear to the novice. The requirements seem to be straightforward; indeed, most of the major requirements for security services can be given self-explanatory, one-word labels: confidentiality, authentication, nonrepudiation, and integrity. But the mechanisms used to meet those requirements can be quite complex, and understanding them may involve rather subtle reasoning.
2. In developing a particular security mechanism or algorithm, one must always consider potential attacks on those security features. In many cases, successful attacks are designed by looking at the problem in a completely different way, therefore exploiting an unexpected weakness in the mechanism.
3. Because of point 2, the procedures used to provide particular services are often counterintuitive. Typically, a security mechanism is complex, and it is not obvious from the statement of a particular requirement that such elaborate measures are needed. It is only when the various aspects of the threat are considered that elaborate security mechanisms make sense.
4. Having designed various security mechanisms, it is necessary to decide where to use them. This is true both in terms of physical placement (e.g., at what points

in a network are certain security mechanisms needed) and in a logical sense [e.g., at what layer or layers of an architecture such as TCP/IP (Transmission Control Protocol/Internet Protocol) should mechanisms be placed].

5. Security mechanisms typically involve more than a particular algorithm or protocol. They also require that participants be in possession of some secret information (e.g., an encryption key), which raises questions about the creation, distribution, and protection of that secret information. There also may be a reliance on communications protocols whose behavior may complicate the task of developing the security mechanism. For example, if the proper functioning of the security mechanism requires setting time limits on the transit time of a message from sender to receiver, then any protocol or network that introduces variable, unpredictable delays may render such time limits meaningless.
6. Information and network security are essentially a battle of wits between a perpetrator who tries to find holes and the designer or administrator who tries to close them. The great advantage that the attacker has is that he or she need only find a single weakness, while the designer must find and eliminate all weaknesses to achieve perfect security.
7. There is a natural tendency on the part of users and system managers to perceive little benefit from security investment until a security failure occurs.
8. Security requires regular, even constant, monitoring, and this is difficult in today's short-term, overloaded environment.
9. Security is still too often an afterthought to be incorporated into a system after the design is complete rather than being an integral part of the design process.
10. Many users and even security administrators view strong security as an impediment to efficient and user-friendly operation of an information system or use of information.

The difficulties just enumerated will be encountered in numerous ways as we examine the various security threats and mechanisms throughout this book.

1.2 THE OSI SECURITY ARCHITECTURE

To assess effectively the security needs of an organization and to evaluate and choose various security products and policies, the manager responsible for security needs some systematic way of defining the requirements for security and characterizing the approaches to satisfying those requirements. This is difficult enough in a centralized data processing environment; with the use of local and wide area networks, the problems are compounded.

ITU-T Recommendation X.800, *Security Architecture for OSI*, defines such a systematic approach. The open systems interconnection (OSI) security architecture is useful to managers as a way of organizing the task of providing security. Furthermore, because this architecture was developed as an international standard, computer and communications vendors have developed security

features for their products and services that relate to this structured definition of services and mechanisms.

For our purposes, the OSI security architecture provides a useful, if abstract, overview of many of the concepts that this book deals with. The OSI security architecture focuses on security attacks, mechanisms, and services. These can be defined briefly as:

- **Security attack:** Any action that compromises the security of information owned by an organization.
- **Security mechanism:** A process (or a device incorporating such a process) that is designed to detect, prevent, or recover from a security attack.
- **Security service:** A processing or communication service that enhances the security of the data processing systems and the information transfers of an organization. The services are intended to counter security attacks, and they make use of one or more security mechanisms to provide the service.

In the literature, the terms *threat* and *attack* are commonly used, with the following meanings:

- **Threat:** Any circumstance or event with the potential to adversely impact organizational operations (including mission, functions, image, or reputation), organizational assets, individuals, other organizations, or the Nation through an information system via unauthorized access, destruction, disclosure, modification of information, and/or denial of service.
- **Attack:** Any kind of malicious activity that attempts to collect, disrupt, deny, degrade, or destroy information system resources or the information itself.

The following three sections provide an overview of the concepts of attacks, services, and mechanisms. The key concepts that are covered are summarized in Figure 1.2.

1.3 SECURITY ATTACKS

A useful means of classifying security attacks, used both in X.800, is in terms of *passive attacks* and *active attacks* (Figure 1.2a). A passive attack attempts to learn or make use of information from the system but does not affect system resources. An active attack attempts to alter system resources or affect their operation.

Passive Attacks

Passive attacks are in the nature of **eavesdropping** on, or monitoring of, transmissions. The goal of the attacker is to obtain information that is being transmitted. Two types of passive attacks are the release of message contents and traffic analysis.

The release of message contents is easily understood. A telephone conversation, an electronic mail message, and a transferred file may contain sensitive or confidential information. We would like to prevent an opponent from learning the contents of these transmissions.

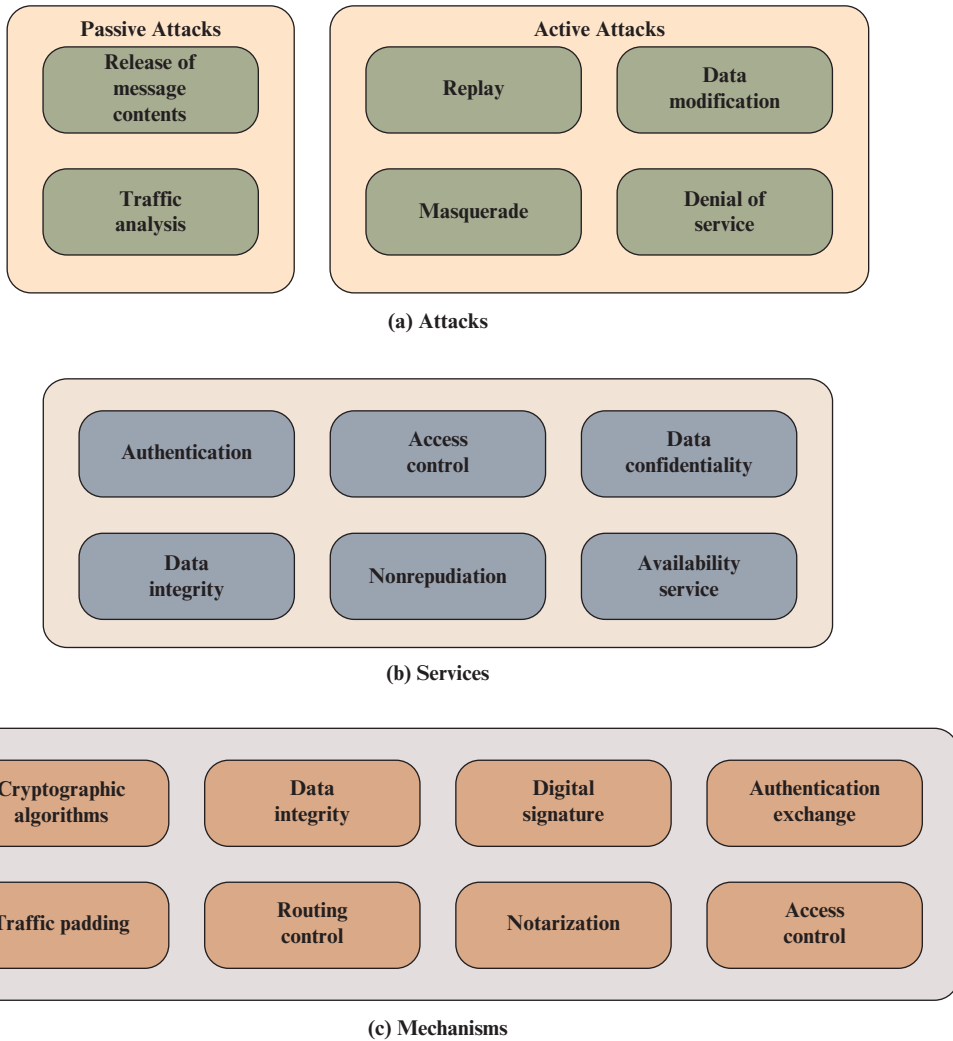

Figure 1.2 Key Concepts in Security

A second type of passive attack, traffic analysis, is subtler. Suppose that we had a way of masking the contents of messages or other information traffic so that opponents, even if they captured the message, could not extract the information from the message. The common technique for masking contents is encryption. If we had encryption protection in place, an opponent might still be able to observe the pattern of these messages. The opponent could determine the location and identity of communicating hosts and could observe the frequency and length of messages being exchanged. This information might be useful in guessing the nature of the communication that was taking place.

Passive attacks are very difficult to detect because they do not involve any alteration of the data. Typically, the message traffic is sent and received in an apparently normal fashion and neither the sender nor receiver is aware that a third party

has read the messages or observed the traffic pattern. However, it is feasible to prevent the success of these attacks, usually by means of encryption. Thus, the emphasis in dealing with passive attacks is on prevention rather than detection.

Active Attacks

Active attacks involve some modification of the data stream or the creation of a false stream and can be subdivided into four categories: replay, masquerade, modification of messages, and denial of service.

A **masquerade** takes place when one entity pretends to be a different entity. A masquerade attack usually includes one of the other forms of active attack. For example, authentication sequences can be captured and replayed after a valid authentication sequence has taken place, thus enabling an authorized entity with few privileges to obtain extra privileges by impersonating an entity that has those privileges.

Replay involves the passive capture of a data unit and its subsequent retransmission to produce an unauthorized effect.

Data modification simply means that some portion of a legitimate message is altered, or that messages are delayed or reordered, to produce an unauthorized effect. For example, a message stating, “Allow John Smith to read confidential file accounts” is modified to say, “Allow Fred Brown to read confidential file accounts.”

The **denial of service** prevents or inhibits the normal use or management of communication facilities. This attack may have a specific target; for example, an entity may suppress all messages directed to a particular destination (e.g., the security audit service). Another form of service denial is the disruption of an entire network, either by disabling the network or by overloading it with messages so as to degrade performance.

Active attacks present the opposite characteristics of passive attacks. Whereas passive attacks are difficult to detect, measures are available to prevent their success. On the other hand, it is quite difficult to prevent active attacks absolutely, because to do so would require physical protection of all communication facilities and paths at all times. Instead, the goal is to detect them and to recover from any disruption or delays caused by them. Because the detection has a deterrent effect, it may also contribute to prevention.

Figure 1.3 illustrates the types of attacks in the context of a client/server interaction. A passive attack (Figure 1.3b) does not disturb the information flow between the client and server, but is able to observe that flow.

A masquerade can take the form of a man-in-the-middle attack (Figure 1.3c). In this type of attack, the attacker intercepts masquerades as the client to the server and as the server to the client. We see specific applications of this attack in defeating key exchange and distribution protocols (Chapters 10 and 14) and in message authentication protocols (Chapter 11). More generally, it can be used to impersonate the two ends of a legitimate communication. Another form of masquerade is illustrated in Figure 1.3d. Here, an attacker is able to access server resources by masquerading as an authorized user.

Data modification may involve a **man-in-the middle attack**, in which the attacker selectively modifies communicated data between a client and server

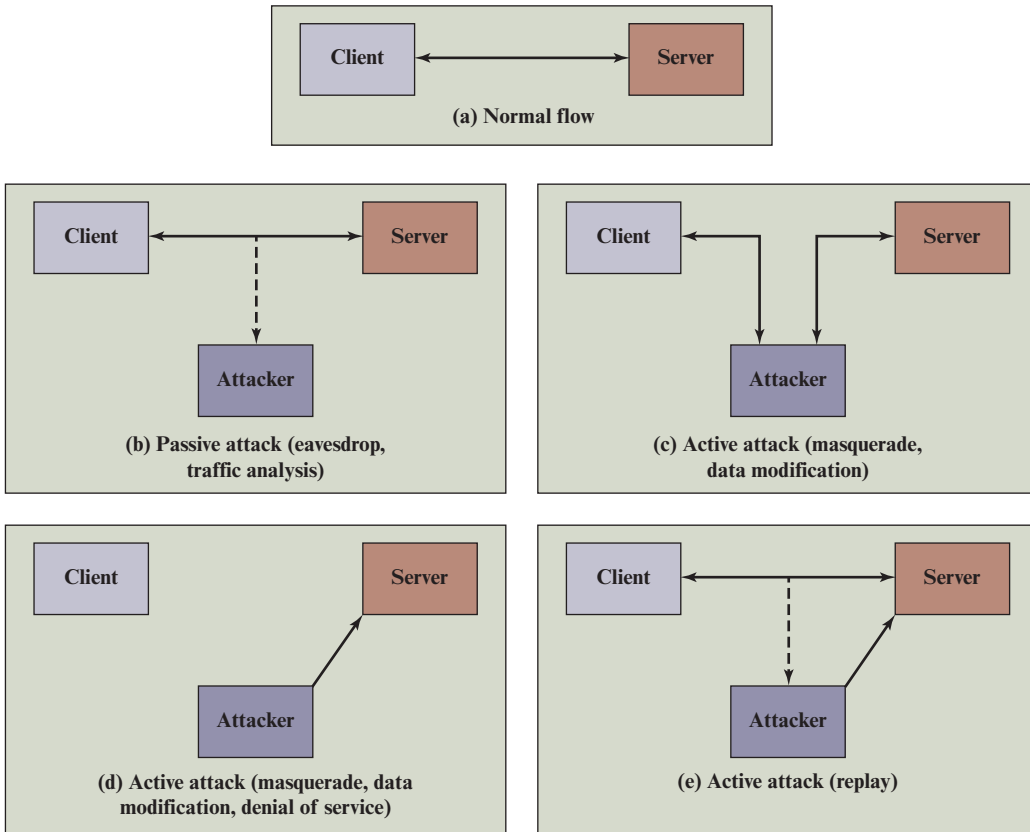

Figure 1.3 Security Attacks

(Figure 1.3c). Another form of data modification attack is the modification of data residing on a server or other system after an attacker gains unauthorized access (Figure 1.3d).

Figure 1.3e illustrates the replay attack. As in a passive attack, the attacker does not disturb the information flow between client and server, but does capture client message. The attacker can then subsequently replay any client message to the server.

Figure 1.3d also illustrates denial of service in the context of a client/server environment. The denial of service can take two forms: (1) flooding the server with an overwhelming amount of data; and (2) triggering some action on the server that consumes substantial computing resources.

1.4 SECURITY SERVICES

A security service is a capability that supports one or more of the security requirements (confidentiality, integrity, availability, authenticity, and accountability). Security services implement security policies and are implemented by security mechanisms.

The most important security services are shown in Figure 1.2b. We look at each category in turn.²

Authentication

The **authentication** service is concerned with assuring that a communication is authentic. In the case of a single message, such as a warning or alarm signal, the function of the authentication service is to assure the recipient that the message is from the source that it claims to be from. In the case of an ongoing interaction, such as the connection of a client to a server, two aspects are involved. First, at the time of connection initiation, the service assures that the two entities are authentic, that is, that each is the entity that it claims to be. Second, the service must assure that the connection is not interfered with in such a way that a third party can masquerade as one of the two legitimate parties for the purposes of unauthorized transmission or reception.

Two specific authentication services are defined in X.800:

- **Peer entity authentication:** Provides for the corroboration of the identity of a peer entity in an association. Two entities are considered peers if they implement the same protocol in different systems; for example, two TCP modules in two communicating systems. Peer entity authentication is provided for use at the establishment of, or at times during the data transfer phase of, a connection. It attempts to provide confidence that an entity is not performing either a masquerade or an unauthorized replay of a previous connection.
- **Data origin authentication:** Provides for the corroboration of the source of a data unit. It does not provide protection against the duplication or modification of data units. This type of service supports applications like electronic mail, where there are no ongoing interactions between the communicating entities.

Access Control

In the context of network security, access control is the ability to limit and control the access to host systems and applications via communications links. To achieve this, each entity trying to gain access must first be identified, or authenticated, so that access rights can be tailored to the individual.

Data Confidentiality

Confidentiality is the protection of transmitted data from passive attacks. With respect to the content of a data transmission, several levels of protection can be identified. The broadest service protects all user data transmitted between two users

²There is no universal agreement about many of the terms used in the security literature. For example, the term *integrity* is sometimes used to refer to all aspects of information security. The term *authentication* is sometimes used to refer both to verification of identity and to the various functions listed under integrity in this chapter. Our usage here agrees with X.800.

over a period of time. For example, when a TCP connection is set up between two systems, this broad protection prevents the release of any user data transmitted over the TCP connection. Narrower forms of this service can also be defined, including the protection of a single message or even specific fields within a message. These refinements are less useful than the broad approach and may even be more complex and expensive to implement.

The other aspect of confidentiality is the protection of traffic flow from analysis. This requires that an attacker not be able to observe the source and destination, frequency, length, or other characteristics of the traffic on a communications facility.

Data Integrity

As with confidentiality, integrity can apply to a stream of messages, a single message, or selected fields within a message. Again, the most useful and straightforward approach is total stream protection.

A connection-oriented integrity service, one that deals with a stream of messages, assures that messages are received as sent with no duplication, insertion, modification, reordering, or replays. The destruction of data is also covered under this service. Thus, the connection-oriented integrity service addresses both message stream modification and denial of service. On the other hand, a connectionless integrity service, one that deals with individual messages without regard to any larger context, generally provides protection against message modification only.

We can make a distinction between service with and without recovery. Because the integrity service relates to active attacks, we are concerned with detection rather than prevention. If a violation of integrity is detected, then the service may simply report this violation, and some other portion of software or human intervention is required to recover from the violation. Alternatively, there are mechanisms available to recover from the loss of integrity of data, as we will review subsequently. The incorporation of automated recovery mechanisms is, in general, the more attractive alternative.

Nonrepudiation

Nonrepudiation prevents either sender or receiver from denying a transmitted message. Thus, when a message is sent, the receiver can prove that the alleged sender in fact sent the message. Similarly, when a message is received, the sender can prove that the alleged receiver in fact received the message.

Availability Service

Availability is the property of a system, or a system resource being accessible and usable upon demand by an authorized system entity, according to performance specifications for the system (i.e., a system is available if it provides services according to the system design whenever users request them). A variety of attacks can result in the loss of or reduction in availability. Some of these attacks are amenable to automated countermeasures, such as authentication and encryption, whereas others require some sort of physical action to prevent or recover from loss of availability of elements of a distributed system.

X.800 treats availability as a property to be associated with various security services. However, it makes sense to call out specifically an availability service. An availability service is one that protects a system to ensure its availability. This service addresses the security concerns raised by denial-of-service attacks. It depends on proper management and control of system resources and thus depends on access control service and other security services.

1.5 SECURITY MECHANISMS

Figure 1.2c lists the most important security mechanisms discussed in this book. These mechanisms will be covered in the appropriate places in the book. So, we do not elaborate now, except to provide the following brief definitions.

- **Cryptographic algorithms:** We can distinguish between reversible cryptographic mechanisms and irreversible cryptographic mechanisms. A reversible cryptographic mechanism is simply an encryption algorithm that allows data to be encrypted and subsequently decrypted. Irreversible cryptographic mechanisms include hash algorithms and message authentication codes, which are used in digital signature and message authentication applications.
- **Data integrity:** This category covers a variety of mechanisms used to assure the integrity of a data unit or stream of data units.
- **Digital signature:** Data appended to, or a cryptographic transformation of, a data unit that allows a recipient of the data unit to prove the source and integrity of the data unit and protect against forgery.
- **Authentication exchange:** A mechanism intended to ensure the identity of an entity by means of information exchange.
- **Traffic padding:** The insertion of bits into gaps in a data stream to frustrate traffic analysis attempts.
- **Routing control:** Enables selection of particular physically or logically secure routes for certain data and allows routing changes, especially when a breach of security is suspected.
- **Notarization:** The use of a trusted third party to assure certain properties of a data exchange.
- **Access control:** A variety of mechanisms that enforce access rights to resources.

1.6 CRYPTOGRAPHY

Cryptography is a branch of mathematics that deals with the transformation of data. Cryptographic algorithms are used in many ways in information security and network security. Cryptography is an essential component in the secure storage and transmission of data, and in the secure interaction between parties. Parts Two through Five are devoted to this topic. Here we provide a very brief overview.

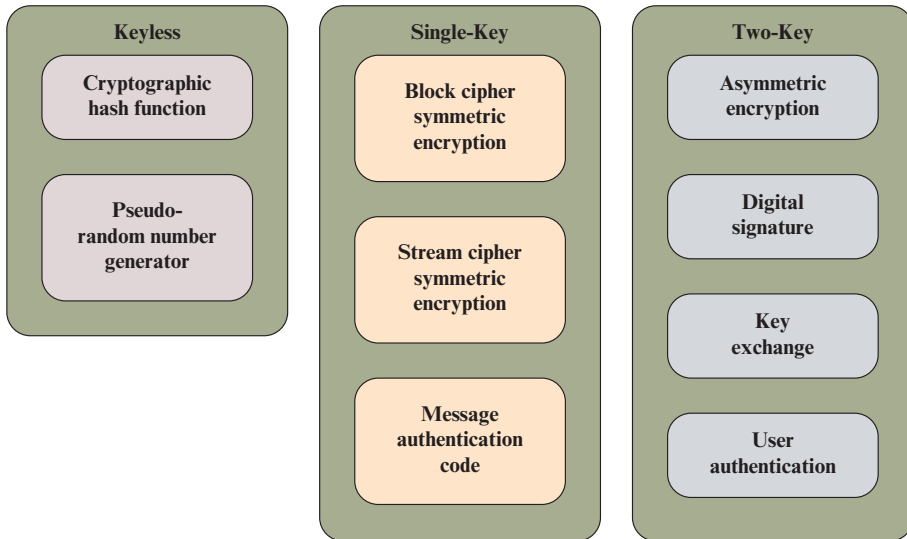

Figure 1.4 Cryptographic Algorithms

Cryptographic algorithms can be divided into three categories (Figure 1.4):

- **Keyless:** Do not use any keys during cryptographic transformations.
- **Single-key:** The result of a transformation is a function of the input data and a single key, known as a secret key.
- **Two-key:** At various stages of the calculation, two different but related keys are used, referred to as a private key and a public key.

Keyless Algorithms

Keyless algorithms are deterministic functions that have certain properties useful for cryptography.

One important type of keyless algorithm is the cryptographic hash function. A hash function turns a variable amount of text into a small, fixed-length value called a *hash value*, *hash code*, or *digest*. A **cryptographic hash function** is one that has additional properties that make it useful as part of another cryptographic algorithm, such as a message authentication code or a digital signature.

A **pseudorandom number generator** produces a deterministic sequence of numbers or bits that has the appearance of being a truly random sequence. Although the sequence appears to lack any definite pattern, it will repeat after a certain sequence length. Nevertheless, for some cryptographic purposes this apparently random sequence is sufficient.

Single-Key Algorithms

Single-key cryptographic algorithms depend on the use of a secret key. This key may be known to a single user; for example, this is the case for protecting stored data that is only going to be accessed by the data creator. Commonly, two parties share the

secret key so that communication between the two parties is protected. For certain applications, more than two users may share the same secret key. In this last case, the algorithm protects data from those outside the group who share the key.

Encryption algorithms that use a single key are referred to as **symmetric encryption algorithms**. With symmetric encryption, an encryption algorithm takes as input some data to be protected and a secret key and produces an unintelligible transformation on that data. A corresponding decryption algorithm takes the transformed data and the same secret key and recovers the original data. Symmetric encryption takes the following forms:

- **Block cipher:** A block cipher operates on data as a sequence of blocks. A typical block size is 128 bits. In most versions of the block cipher, known as modes of operation, the transformation depends not only on the current data block and the secret key but also on the content of preceding blocks.
- **Stream cipher:** A stream cipher operates on data as a sequence of bits. Typically, an exclusive-OR operation is used to produce a bit-by-bit transformation. As with the block cipher, the transformation depends on a secret key.

Another form of single-key cryptographic algorithm is the **message authentication code (MAC)**. A MAC is a data element associated with a data block or message. The MAC is generated by a cryptographic transformation involving a secret key and, typically, a cryptographic hash function of the message. The MAC is designed so that someone in possession of the secret key can verify the integrity of the message. Thus, the MAC algorithm takes as input a message and secret key and produces the MAC. The recipient of the message plus the MAC can perform the same calculation on the message; if the calculated MAC matches the MAC accompanying the message, this provides assurance that the message has not been altered.

Two-Key Algorithms

Two-key algorithms involve the use of two related keys. A private key is known only to a single user or entity, whereas the corresponding public key is made available to a number of users. Encryption algorithms that use two keys are referred to as **asymmetric encryption algorithms**. Asymmetric encryption can work in two ways:

1. An encryption algorithm takes as input some data to be protected and the private key and produces an unintelligible transformation on that data. A corresponding decryption algorithm takes the transformed data and the corresponding public key and recovers the original data. In this case, only the possessor of the private key can have performed the encryption and any possessor of the public key can perform the decryption.
2. An encryption algorithm takes as input some data to be protected and a public key and produces an unintelligible transformation on that data. A corresponding decryption algorithm takes the transformed data and the corresponding private key and recovers the original data. In this case, any possessor of the public key can have performed the encryption and only the possessor of the private key can perform the decryption.

Asymmetric encryption has a variety of applications. One of the most important is the **digital signature algorithm**. A digital signature is a value computed with a cryptographic algorithm and associated with a data object in such a way that any recipient of the data can use the signature to verify the data's origin and integrity. Typically, the signer of a data object uses the signer's private key to generate the signature, and anyone in possession of the corresponding public key can verify that validity of the signature.

Asymmetric algorithms can also be used in two other important applications. **Key exchange** is the process of securely distributing a symmetric key to two or more parties. **User authentication** is the process of authenticating that a user attempting to access an application or service is genuine and, similarly, that the application or service is genuine. These concepts are explained in detail in subsequent chapters.

1.7 NETWORK SECURITY

Network security is a broad term that encompasses security of the communications pathways of the network and the security of network devices and devices attached to the network (Figure 1.5).

Communications Security

In the context of network security, communications security deals with the protection of communications through the network, including measures to protect against both passive and active attacks (Figure 1.3).

Communications security is primarily implemented using network protocols. A network protocol consists of the format and procedures that governs the transmitting and receiving of data between points in a network. A protocol defines the structure of the individual data units (e.g., packets) and the control commands that manage the data transfer.

With respect to network security, a security protocol may be an enhancement that is part of an existing protocol or a standalone protocol. Examples of the former are IPsec, which is part of the Internet Protocol (IP) and IEEE 802.11i, which is part of the IEEE 802.11 Wi-Fi standard. Examples of the latter are Transport Layer Security (TLS) and Secure Shell (SSH). Part Six examines these and other secure network protocols.

One common characteristic of all of these protocols is that they use a number of cryptographic algorithms as part of the mechanism to provide security.

Device Security

The other aspect of network security is the protection of network devices, such as routers and switches, and end systems connected to the network, such as client systems and servers. The primary security concerns are intruders that gain access to the system to perform unauthorized actions, insert malicious software (malware), or overwhelm system resources to diminish availability. Three types of device security are noteworthy:

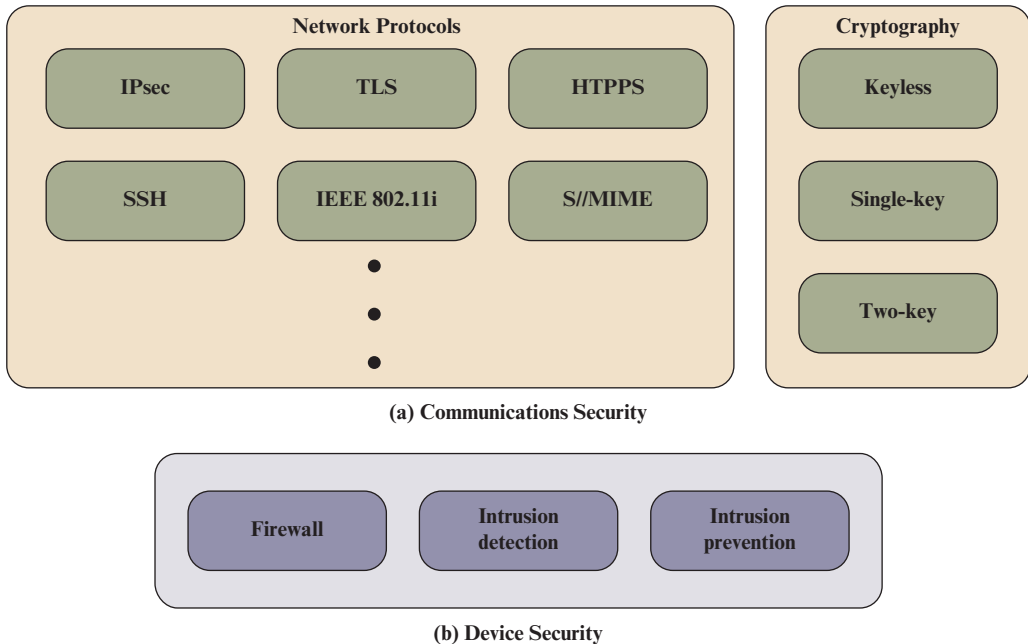

Figure 1.5 Key Elements of Network Security

- **Firewall:** A hardware and/or software capability that limits access between a network and devices attached to the network, in accordance with a specific security policy. The firewall acts as a filter that permits or denies data traffic, both incoming and outgoing, using a set of rules based on traffic content and/or traffic pattern.
- **Intrusion detection:** Hardware or software products that gather and analyze information from various areas within a computer or a network for the purpose of finding, and providing real-time or near-real-time warning of, attempts to access system resources in an unauthorized manner.
- **Intrusion prevention:** Hardware or software products designed to detect intrusive activity and attempt to stop the activity, ideally before it reaches its target.

These device security capabilities are more closely related to the field of computer security than network security. Accordingly, they are dealt with more briefly than communications security in Part Six. For a more detailed treatment, see [STAL18].

1.8 TRUST AND TRUSTWORTHINESS

The concepts of trust and trustworthiness are key concepts in computer and network security [SCHN91]. It will be useful to look first at a generalized model of trust and trustworthiness, and then apply these concepts to the topic of information security.

A Trust Model

One of the most widely accepted and most cited definitions of trust in the organizational science literature is from [MAYE95], which defines **trust** as follows: the willingness of a party to be vulnerable to the actions of another party based on the expectation that the other will perform a particular action important to the truster, irrespective of the ability to monitor or control that other party.

Three related concepts are relevant to a trust model:

- **Trustworthiness:** A characteristic of an entity that reflects the degree to which that entity is deserving of trust.
- **Propensity to trust:** A tendency to be willing to trust others across a broad spectrum of situations and trust targets. This suggests that every individual has some baseline level of trust that will influence the person's willingness to rely on the words and actions of others.
- **Risk:** A measure of the extent to which an entity is threatened by a potential circumstance or event, and typically a function of 1) the adverse impacts that would arise if the circumstance or event occurs; and 2) the likelihood of occurrence.

Figure 1.6, adapted from [MAYE95], illustrates the relationship among these concepts. Trust is a function of the truster's propensity to trust and the perceived trustworthiness of the trustee. Propensity can also be expressed as the level of risk that an entity (individual or organization) is prepared to tolerate.

Typically, a truster uses a number of factors to establish the trustworthiness of an entity. Three general factors are commonly cited:

- **Ability:** Also referred to as *competence*, this relates to the potential ability of the evaluated entity to do a given task or be entrusted with given information.
- **Benevolence:** This implies a disposition of goodwill towards the trusting party. That is, a trustworthy party does not intend to cause harm to the trusting party.
- **Integrity:** This can be defined as the truster's perception that the trustee adheres to a set of principles that the truster finds acceptable. Integrity implies that a benevolent party takes such measures are necessary to assure that it in fact does not cause harm to the trusting party.

The goal of trust, in the model of Figure 1.6, is to determine what course of action, if any, the trusting party is willing to take in relation to the trusted party. Based on the level of trust, and the perceived risk, the trusting party may decide to take some action that involves some degree of risk taking. The outcome of the risk taking could be a reliance on the trusted party to perform some action or the disclosure of information to the trusted party with the expectation that the information will be protected as agreed between the parties.

The Trust Model and Information Security

Trust is confidence that an entity will perform in a way that will not prejudice the security of the user of the system of which that entity is a part. Trust is always restricted to specific functions or ways of behavior and is meaningful only in the

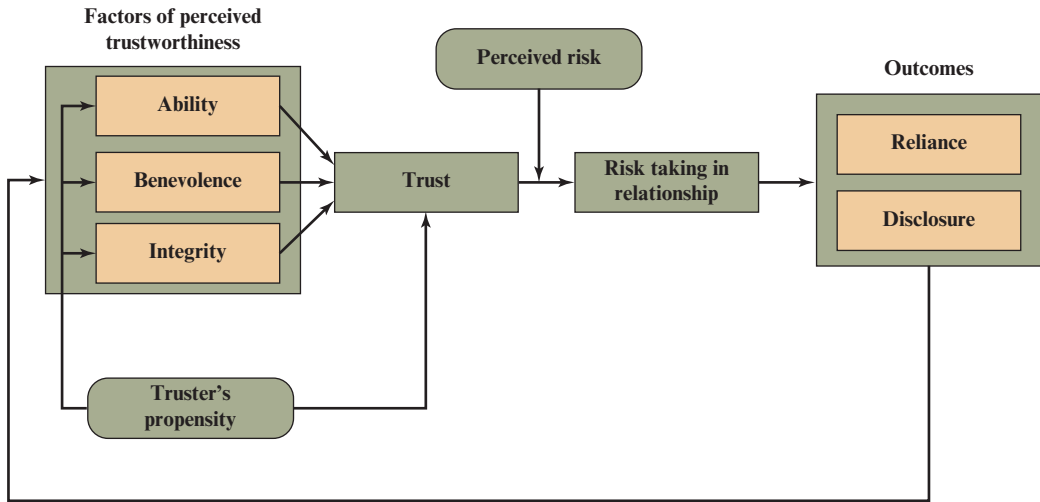

Figure 1.6 Trust Model

context of a security policy. Generally, an entity is said to trust a second entity when the first entity assumes that the second entity will behave exactly as the first entity expects. This trust may apply only for some specific function. In this context, the term *entity* may refer to a single hardware component or software module, a piece of equipment identified by make and model, a site or location, or an organization.

TRUSTWORTHINESS OF AN INDIVIDUAL Organizations need to be concerned about both internal users (employees, on-site contractors) and external users (customers, suppliers) of their information systems. With respect to internal users, an organization develops a level of trust in individuals by policies in the following two areas [STAL19]:

- **Human resource security:** Sound security practice dictates that information security requirements be embedded into each stage of the employment life cycle, specifying security-related actions required during the induction of each individual, their ongoing management, and termination of their employment. Human resource security also includes assigning ownership of information (including responsibility for its protection) to capable individuals and obtaining confirmation of their understanding and acceptance.
- **Security awareness and training:** This area refers to disseminating security information to all employees, including IT staff, IT security staff, and management, as well as IT users and other employees. A workforce that has a high level of security awareness and appropriate security training for each individual's role is as important, if not more important, than any other security countermeasure or control.

For external users, trust will depend on the context. In general terms, the factors of perceived trustworthiness and the truster's propensity, as depicted in Figure 1.6, determine the level of trust. Further, the issue of trust is mutual. That is, not only must an organization determine a level of trust towards external users, but external users

need to be concerned about the degree to which they can trust an information resource that they use. This mutual trust involves a number of practical consequences, including the use of a public-key infrastructure and user authentication protocols. These matters are explored in Part Five.

TRUSTWORTHINESS OF AN ORGANIZATION Most organizations rely, to a greater or lesser extent, on information system service and information provided by external organizations, as well as partnerships to accomplish missions and business functions. Examples are cloud service providers and companies that form part of the supply chain for the organization. To manage risk to the organization, it must establish trust relationships with these external organizations. NIST SP 800-39 (*Managing Information Security Risk*, March 2011) indicates that such trust relationships can be:

- Formally established, for example, by documenting the trust-related information in contracts, service-level agreements, statements of work, memoranda of agreement/understanding, or interconnection security agreements;
- Scalable and inter-organizational or intra-organizational in nature; and/or
- Represented by simple (bilateral) relationships between two partners or more complex many-to-many relationships among many diverse partners.

The requirements for establishing and maintaining trust depend on mission/business requirements, the participants involved in the trust relationship, the criticality/sensitivity of the information being shared or the types of services being rendered, the history between the organizations, and the overall risk to the organizations participating in the relationship.

As with individuals, trust related to organizations can involve the use of public-key infrastructure and user authentication, as well as the network security measures described in Part Six.

TRUSTWORTHINESS OF INFORMATION SYSTEMS SP 800-39 defines trustworthiness for information systems as the degree to which information systems (including the information technology products from which the systems are built) can be expected to preserve the confidentiality, integrity, and availability of the information being processed, stored, or transmitted by the systems across the full range of threats. Two factors affecting the trustworthiness of information systems are:

- **Security functionality:** The security features/functions employed within the system. These include cryptographic and network security technologies discussed throughout this book.
- **Security assurance:** The grounds for confidence that the security functionality is effective in its application. This area is addressed by security management techniques, such as auditing and incorporating security considerations into the system development life cycle [STAL19].

Establishing Trust Relationships

The methods used by an organization to establish a **trust relationship** with various entities will depend on a variety of factors, such as laws and regulations, risk tolerance, and the criticality and sensitivity of the relationship. SP 800-39 describes the following methods:

- **Validated trust:** Trust is based on evidence obtained by the trusting organization about the trusted organization or entity. The information may include information security policy, security measures, and level of oversight. An example would be for one organization to develop an application or information system and provide evidence (e.g., security plan, assessment results) to a second organization that supports the claims by the first organization that the application/system meets certain security requirements and/or addresses the appropriate security controls.
- **Direct historical trust:** This type of trust is based on the security-related track record exhibited by an organization in the past, particularly in interactions with the organization seeking to establish trust.
- **Mediated trust:** Mediated trust involves the use of a third party that is mutually trusted by two parties, with the third party providing assurance or guarantee of a given level of trust between the first two parties. An example of this form of trust establishment is the use of public-key certificate authorities, described in Chapter 14.
- **Mandated trust:** An organization establishes a level of trust with another organization based on a specific mandate issued by a third party in a position of authority. For example, an organization may be given the responsibility and the authority to issue public key certificates for a group of organizations.

An organization is likely to use a combination of these methods to establish relationships with a number of other entities.

1.9 STANDARDS

Many of the security techniques and applications described in this book have been specified as standards. Additionally, standards have been developed to cover management practices and the overall architecture of security mechanisms and services. Throughout this book, we describe the most important standards in use or being developed for various aspects of cryptography and network security. Various organizations have been involved in the development or promotion of these standards. The most important (in the current context) of these organizations are as follows:

- **National Institute of Standards and Technology:** NIST is a U.S. federal agency that deals with measurement science, standards, and technology related to U.S. government use and to the promotion of U.S. private-sector innovation. Despite its national scope, NIST Federal Information Processing Standards (FIPS) and Special Publications (SP) have a worldwide impact.
- **Internet Society:** ISOC is a professional membership society with worldwide organizational and individual membership. It provides leadership in addressing issues that confront the future of the Internet and is the organization home for the groups responsible for Internet infrastructure standards, including the Internet Engineering Task Force (IETF) and the Internet Architecture Board (IAB). These organizations develop Internet standards and related specifications, all of which are published as Requests for Comments (RFCs).

- **ITU-T:** The International Telecommunication Union (ITU) is an international organization within the United Nations System in which governments and the private sector coordinate global telecom networks and services. The ITU Telecommunication Standardization Sector (ITU-T) is one of the three sectors of the ITU. ITU-T's mission is the development of technical standards covering all fields of telecommunications. ITU-T standards are referred to as Recommendations.
- **ISO:** The International Organization for Standardization (ISO) is a worldwide federation of national standards bodies from more than 140 countries, one from each country. ISO is a nongovernmental organization that promotes the development of standardization and related activities with a view to facilitating the international exchange of goods and services and to developing cooperation in the spheres of intellectual, scientific, technological, and economic activity. ISO's work results in international agreements that are published as International Standards.

1.10 KEY TERMS, REVIEW QUESTIONS, AND PROBLEMS

Key Terms

access control	digital signature algorithms	pseudorandom number generator
active attack	eavesdropping	replay
asymmetric encryption algorithms	encryption	routing control
attack	firewall	security attack
authentication	information security	security mechanism
authentication exchange	intrusion detection	security service
authenticity	intrusion prevention	single-key algorithm
availability	key exchange	stream cipher
block cipher	keyless algorithm	symmetric encryption algorithms
confidentiality	man-in-the-middle attack	system integrity
cryptographic hash function	masquerade	threat
cryptography	message authentication code	trust
cybersecurity	network security	trust relationship
data authenticity	notarization	trustworthiness
data confidentiality	OSI security architecture	two-key algorithm
data integrity	passive attack	user authentication
data origin authentication	peer entity authentication	
denial of service	privacy	

Review Questions

- 1.1 What is the OSI security architecture?
- 1.2 List and briefly define the three key objectives of computer security.
- 1.3 List and briefly define categories of passive and active security attacks.
- 1.4 List and briefly define categories of security services.
- 1.5 List and briefly define categories of security mechanisms.
- 1.6 List and briefly define the fundamental security design principles.

- 1.7 Provide an overview of the three types of cryptographic algorithms.
- 1.8 Provide an overview of the two major elements of network security.
- 1.9 Briefly explain the concepts of trust and trustworthiness.

Problems

- 1.1 Consider an automated cash deposit machine in which users provide a card or an account number to deposit cash. Give examples of confidentiality, integrity, and availability requirements associated with the system, and, in each case, indicate the degree of importance of the requirement.
- 1.2 Repeat Problem 1.1 for a payment gateway system where a user pays for an item using their account via the payment gateway.
- 1.3 Consider a financial report publishing system used to produce reports for various organizations.
 - a. Give an example of a type of publication for which confidentiality of the stored data is the most important requirement.
 - b. Give an example of a type of publication in which data integrity is the most important requirement.
 - c. Give an example in which system availability is the most important requirement.
- 1.4 For each of the following assets, assign a low, moderate, or high impact level for the loss of confidentiality, availability, and integrity, respectively. Justify your answers.
 - a. A student maintaining a blog to post public information.
 - b. An examination section of a university that is managing sensitive information about exam papers.
 - c. An information system in a pathological laboratory maintaining the patient's data.
 - d. A student information system used for maintaining student data in a university that contains both personal, academic information and routine administrative information (not privacy related). Assess the impact for the two data sets separately and the information system as a whole.
 - e. A university library contains a library management system, which controls the distribution of books among the students of various departments. The library management system contains both the student data and the book data. Assess the impact for the two data sets separately and the information system as a whole.
- 1.5 It is useful to read some of the classic tutorial papers on computer security; these provide a historical perspective from which to appreciate current work and thinking. The following are good examples:

- Browne, P. "Computer Security—A Survey." *ACM SIGMIS Database*, Fall 1972.
- LAMP04 Lampson, B. "Computer Security in the Real World," *Computer*, June 2004.
- Saltzer, J., and Schroeder, M. "The Protection of Information in Computer Systems." *Proceedings of the IEEE*, September 1975.
- Shanker, K. "The Total Computer Security Problem: An Overview." *Computer*, June 1977.
- Summers, R. "An Overview of Computer Security." *IBM Systems Journal*, Vol. 23, No. 4, 1984.
- Ware, W., ed. *Security Controls for Computer Systems. RAND Report 609-1. October 1979.*

Read all of these papers. The papers are available at box.com/Crypto8e. Compose a 500–1000 word paper (or 8–12 slide PowerPoint presentation) that summarizes the key concepts that emerge from these papers, emphasizing concepts that are common to most or all of the papers.

INTRODUCTION TO NUMBER THEORY

2.1 Divisibility and The Division Algorithm

Divisibility
The Division Algorithm

2.2 The Euclidean Algorithm

Greatest Common Divisor
Finding the Greatest Common Divisor

2.3 Modular Arithmetic

The Modulus
Properties of Congruences
Modular Arithmetic Operations
Properties of Modular Arithmetic
Euclidean Algorithm Revisited
The Extended Euclidean Algorithm

2.4 Prime Numbers

2.5 Fermat's and Euler's Theorems

Fermat's Theorem
Euler's Totient Function
Euler's Theorem

2.6 Testing for Primality

Miller–Rabin Algorithm
A Deterministic Primality Algorithm
Distribution of Primes

2.7 The Chinese Remainder Theorem

2.8 Discrete Logarithms

The Powers of an Integer, Modulo n
Logarithms for Modular Arithmetic
Calculation of Discrete Logarithms

2.9 Key Terms, Review Questions, and Problems

Appendix 2A The Meaning of Mod

LEARNING OBJECTIVES

After studying this chapter, you should be able to:

- ◆ Understand the concept of divisibility and the division algorithm.
- ◆ Understand how to use the Euclidean algorithm to find the greatest common divisor.
- ◆ Present an overview of the concepts of modular arithmetic.
- ◆ Explain the operation of the extended Euclidean algorithm.
- ◆ Discuss key concepts relating to prime numbers.
- ◆ Understand Fermat's theorem.
- ◆ Understand Euler's theorem.
- ◆ Define Euler's totient function.
- ◆ Make a presentation on the topic of testing for primality.
- ◆ Explain the Chinese remainder theorem.
- ◆ Define discrete logarithms.

Number theory is pervasive in cryptographic algorithms. This chapter provides sufficient breadth and depth of coverage of relevant number theory topics for understanding the wide range of applications in cryptography. The reader familiar with these topics can safely skip this chapter.

The first three sections introduce basic concepts from number theory that are needed for understanding finite fields; these include divisibility, the Euclidean algorithm, and modular arithmetic. The reader may study these sections now or wait until ready to tackle Chapter 5 on finite fields.

Sections 2.4 through 2.8 discuss aspects of number theory related to prime numbers and discrete logarithms. These topics are fundamental to the design of asymmetric (public-key) cryptographic algorithms. The reader may study these sections now or wait until ready to read Part Three.

The concepts and techniques of number theory are quite abstract, and it is often difficult to grasp them intuitively without examples. Accordingly, this chapter includes a number of examples, each of which is highlighted in a shaded box.

2.1 DIVISIBILITY AND THE DIVISION ALGORITHM

Divisibility

We say that a nonzero b **divides** a if $a = mb$ for some m , where a , b , and m are integers. That is, b divides a if there is no remainder on division. The notation $b|a$ is commonly used to mean b divides a . Also, if $b|a$, we say that b is a **divisor** of a .

The positive divisors of 24 are 1, 2, 3, 4, 6, 8, 12, and 24.
 $13 \mid 182$; $-5 \mid 30$; $17 \mid 289$; $-3 \mid 33$; $17 \mid 0$

Subsequently, we will need some simple properties of divisibility for integers, which are as follows:

- If $a \mid 1$, then $a = \pm 1$.
- If $a \mid b$ and $b \mid a$, then $a = \pm b$.
- Any $b \neq 0$ divides 0.
- If $a \mid b$ and $b \mid c$, then $a \mid c$:

$$11 \mid 66 \text{ and } 66 \mid 198 \Rightarrow 11 \mid 198$$

- If $b \mid g$ and $b \mid h$, then $b \mid (mg + nh)$ for arbitrary integers m and n .

To see this last point, note that

- If $b \mid g$, then g is of the form $g = b \times g_1$ for some integer g_1 .
- If $b \mid h$, then h is of the form $h = b \times h_1$ for some integer h_1 .

So

$$mg + nh = mbg_1 + nbh_1 = b \times (mg_1 + nh_1)$$

and therefore b divides $mg + nh$.

$b = 7$; $g = 14$; $h = 63$; $m = 3$; $n = 2$
 $7 \mid 14$ and $7 \mid 63$.
 To show $7 \mid (3 \times 14 + 2 \times 63)$,
 we have $(3 \times 14 + 2 \times 63) = 7(3 \times 2 + 2 \times 9)$,
 and it is obvious that $7 \mid (7(3 \times 2 + 2 \times 9))$.

The Division Algorithm

Given any positive integer n and any nonnegative integer a , if we divide a by n , we get an integer quotient q and an integer remainder r that obey the following relationship:

$$a = qn + r \quad 0 \leq r < n; q = \lfloor a/n \rfloor \quad (2.1)$$

where $\lfloor x \rfloor$ is the largest integer less than or equal to x . Equation (2.1) is referred to as the division algorithm.¹

¹Equation (2.1) expresses a theorem rather than an algorithm, but by tradition, this is referred to as the division algorithm.

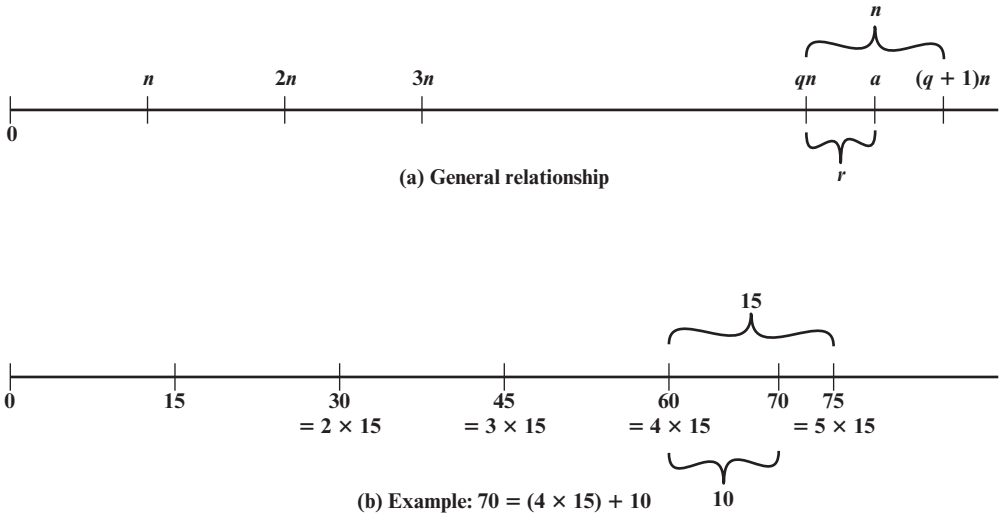

Figure 2.1 The Relationship $a = qn + r; 0 \leq r < n$

Figure 2.1a demonstrates that, given a and positive n , it is always possible to find q and r that satisfy the preceding relationship. Represent the integers on the number line; a will fall somewhere on that line (positive a is shown, a similar demonstration can be made for negative a). Starting at 0, proceed to $n, 2n$, up to qn , such that $qn \leq a$ and $(q + 1)n > a$. The distance from qn to a is r , and we have found the unique values of q and r . The remainder r is often referred to as a **residue**.

$$a = 11; \quad n = 7; \quad 11 = 1 \times 7 + 4; \quad r = 4 \quad q = 1$$

$$a = -11; \quad n = 7; \quad -11 = (-2) \times 7 + 3; \quad r = 3 \quad q = -2$$

Figure 2.1b provides another example.

2.2 THE EUCLIDEAN ALGORITHM

One of the basic techniques of number theory is the Euclidean algorithm, which is a simple procedure for determining the greatest common divisor of two positive integers. First, we need a simple definition: Two integers are **relatively prime** if and only if their only common positive integer factor is 1.

Greatest Common Divisor

Recall that nonzero b is defined to be a divisor of a if $a = mb$ for some m , where a, b , and m are integers. We will use the notation $\text{gcd}(a, b)$ to mean the **greatest common divisor** of a and b . The greatest common divisor of a and b is the largest integer that divides both a and b . We also define $\text{gcd}(0, 0) = 0$.

More formally, the positive integer c is said to be the greatest common divisor of a and b if

1. c is a divisor of a and of b .
2. any divisor of a and b is a divisor of c .

An equivalent definition is the following:

$$\gcd(a, b) = \max\{k, \text{ such that } k|a \text{ and } k|b\}$$

Because we require that the greatest common divisor be positive, $\gcd(a, b) = \gcd(a, -b) = \gcd(-a, b) = \gcd(-a, -b)$. In general, $\gcd(a, b) = \gcd(|a|, |b|)$.

$$\gcd(60, 24) = \gcd(60, -24) = 12$$

Also, because all nonzero integers divide 0, we have $\gcd(a, 0) = |a|$.

We stated that two integers a and b are relatively prime if and only if their only common positive integer factor is 1. This is equivalent to saying that a and b are relatively prime if $\gcd(a, b) = 1$.

8 and 15 are relatively prime because the positive divisors of 8 are 1, 2, 4, and 8, and the positive divisors of 15 are 1, 3, 5, and 15. So 1 is the only integer on both lists.

Finding the Greatest Common Divisor

We now describe an algorithm credited to Euclid for easily finding the greatest common divisor of two integers (Figure 2.2). This algorithm has broad significance in cryptography. The explanation of the algorithm can be broken down into the following points:

1. Suppose we wish to determine the greatest common divisor d of the integers a and b ; that is determine $d = \gcd(a, b)$. Because $\gcd(|a|, |b|) = \gcd(a, b)$, there is no harm in assuming $a \geq b > 0$.
2. Dividing a by b and applying the division algorithm, we can state:

$$a = q_1b + r_1 \quad 0 \leq r_1 < b \quad (2.2)$$

3. First consider the case in which $r_1 = 0$. Therefore b divides a and clearly no larger number divides both b and a , because that number would be larger than b . So we have $d = \gcd(a, b) = b$.
4. The other possibility from Equation (2.2) is $r_1 \neq 0$. For this case, we can state that $d|r_1$. This is due to the basic properties of divisibility: the relations $d|a$ and $d|b$ together imply that $d|(a - q_1b)$, which is the same as $d|r_1$.
5. Before proceeding with the Euclidian algorithm, we need to answer the question: What is the $\gcd(b, r_1)$? We know that $d|b$ and $d|r_1$. Now take any arbitrary integer c that divides both b and r_1 . Therefore, $c|(q_1b + r_1) = a$. Because c divides both a and b , we must have $c \leq d$, which is the greatest common divisor of a and b . Therefore $d = \gcd(b, r_1)$.

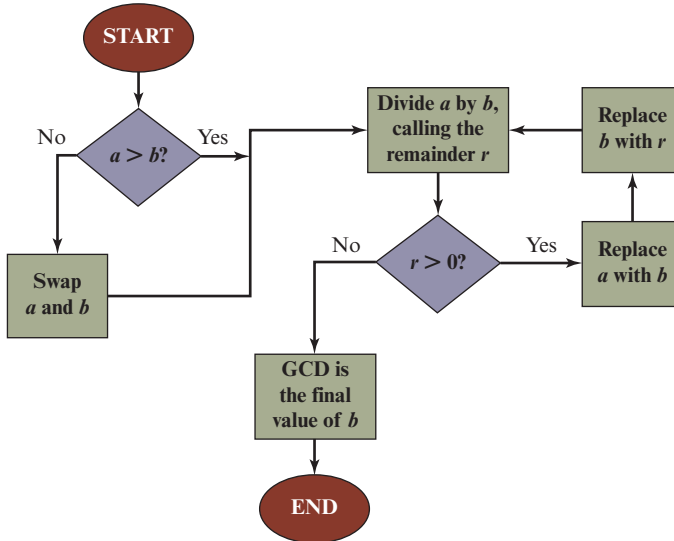

Figure 2.2 Euclidean Algorithm

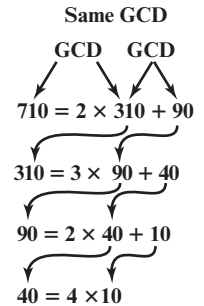

Figure 2.3 Euclidean Algorithm Example: $\text{gcd}(710, 310)$

Let us now return to Equation (2.2) and assume that $r_1 \neq 0$. Because $b > r_1$, we can divide b by r_1 and apply the division algorithm to obtain:

$$b = q_2 r_1 + r_2 \quad 0 \leq r_2 < r_1$$

As before, if $r_2 = 0$, then $d = r_1$ and if $r_2 \neq 0$, then $d = \text{gcd}(r_1, r_2)$. Note that the remainders form a descending series of nonnegative values and so must terminate when the remainder is zero. This happens, say, at the $(n + 1)$ th stage where r_{n-1} is divided by r_n . The result is the following system of equations:

$$\left. \begin{array}{l}
 a = q_1 b + r_1 \quad 0 < r_1 < b \\
 b = q_2 r_1 + r_2 \quad 0 < r_2 < r_1 \\
 r_1 = q_3 r_2 + r_3 \quad 0 < r_3 < r_2 \\
 \cdot \quad \quad \quad \cdot \\
 \cdot \quad \quad \quad \cdot \\
 \cdot \quad \quad \quad \cdot \\
 r_{n-2} = q_n r_{n-1} + r_n \quad 0 < r_n < r_{n-1} \\
 r_{n-1} = q_{n+1} r_n + 0 \\
 d = \text{gcd}(a, b) = r_n
 \end{array} \right\} \quad (2.3)$$

At each iteration, we have $d = \text{gcd}(r_i, r_{i+1})$ until finally $d = \text{gcd}(r_n, 0) = r_n$. Thus, we can find the greatest common divisor of two integers by repetitive application of the division algorithm. This scheme is known as the Euclidean algorithm. Figure 2.3 illustrates a simple example.

We have essentially argued from the top down that the final result is the $\text{gcd}(a, b)$. We can also argue from the bottom up. The first step is to show that r_n divides a and b . It follows from the last division in Equation (2.3) that r_n divides r_{n-1} . The next to last division shows that r_n divides r_{n-2} because it divides both

terms on the right. Successively, one sees that r_n divides all r_i 's and finally a and b . It remains to show that r_n is the largest divisor that divides a and b . If we take any arbitrary integer that divides a and b , it must also divide r_1 , as explained previously. We can follow the sequence of equations in Equation (2.3) down and show that c must divide all r_i 's. Therefore c must divide r_n , so that $r_n = \gcd(a, b)$.

Let us now look at an example with relatively large numbers to see the power of this algorithm:

To find $d = \gcd(a, b) = \gcd(1160718174, 316258250)$		
$a = q_1b + r_1$	$1160718174 = 3 \times 316258250 + 211943424$	$d = \gcd(316258250, 211943424)$
$b = q_2r_1 + r_2$	$316258250 = 1 \times 211943424 + 104314826$	$d = \gcd(211943424, 104314826)$
$r_1 = q_3r_2 + r_3$	$211943424 = 2 \times 104314826 + 3313772$	$d = \gcd(104314826, 3313772)$
$r_2 = q_4r_3 + r_4$	$104314826 = 31 \times 3313772 + 1587894$	$d = \gcd(3313772, 1587894)$
$r_3 = q_5r_4 + r_5$	$3313772 = 2 \times 1587894 + 137984$	$d = \gcd(1587894, 137984)$
$r_4 = q_6r_5 + r_6$	$1587894 = 11 \times 137984 + 70070$	$d = \gcd(137984, 70070)$
$r_5 = q_7r_6 + r_7$	$137984 = 1 \times 70070 + 67914$	$d = \gcd(70070, 67914)$
$r_6 = q_8r_7 + r_8$	$70070 = 1 \times 67914 + 2156$	$d = \gcd(67914, 2156)$
$r_7 = q_9r_8 + r_9$	$67914 = 31 \times 2156 + 1078$	$d = \gcd(2156, 1078)$
$r_8 = q_{10}r_9 + r_{10}$	$2156 = 2 \times 1078 + 0$	$d = \gcd(1078, 0) = 1078$
Therefore, $d = \gcd(1160718174, 316258250) = 1078$		

In this example, we begin by dividing 1160718174 by 316258250, which gives 3 with a remainder of 211943424. Next we take 316258250 and divide it by 211943424. The process continues until we get a remainder of 0, yielding a result of 1078.

It will be helpful in what follows to recast the above computation in tabular form. For every step of the iteration, we have $r_{i-2} = q_i r_{i-1} + r_i$, where r_{i-2} is the dividend, r_{i-1} is the divisor, q_i is the quotient, and r_i is the remainder. Table 2.1 summarizes the results.

Table 2.1 Euclidean Algorithm Example

Dividend	Divisor	Quotient	Remainder
$a = 1160718174$	$b = 316258250$	$q_1 = 3$	$r_1 = 211943424$
$b = 316258250$	$r_1 = 211943434$	$q_2 = 1$	$r_2 = 104314826$
$r_1 = 211943424$	$r_2 = 104314826$	$q_3 = 2$	$r_3 = 3313772$
$r_2 = 104314826$	$r_3 = 3313772$	$q_4 = 31$	$r_4 = 1587894$
$r_3 = 3313772$	$r_4 = 1587894$	$q_5 = 2$	$r_5 = 137984$
$r_4 = 1587894$	$r_5 = 137984$	$q_6 = 11$	$r_6 = 70070$
$r_5 = 137984$	$r_6 = 70070$	$q_7 = 1$	$r_7 = 67914$
$r_6 = 70070$	$r_7 = 67914$	$q_8 = 1$	$r_8 = 2156$
$r_7 = 67914$	$r_8 = 2156$	$q_9 = 31$	$r_9 = 1078$
$r_8 = 2156$	$r_9 = 1078$	$q_{10} = 2$	$r_{10} = 0$

2.3 MODULAR ARITHMETIC

The Modulus

If a is an integer and n is a positive integer, we define $a \bmod n$ to be the remainder when a is divided by n . The integer n is called the **modulus**. Thus, for any integer a , we can rewrite Equation (2.1) as follows:

$$\begin{aligned} a &= qn + r & 0 \leq r < n; q &= \lfloor a/n \rfloor \\ a &= \lfloor a/n \rfloor \times n + (a \bmod n) \end{aligned}$$

$$11 \bmod 7 = 4; \quad -11 \bmod 7 = 3$$

Two integers a and b are said to be **congruent modulo n** , if $(a \bmod n) = (b \bmod n)$. This is written as $a \equiv b \pmod{n}$.²

$$73 \equiv 4 \pmod{23}; \quad 21 \equiv -9 \pmod{10}$$

Note that if $a \equiv 0 \pmod{n}$, then $n \mid a$.

Properties of Congruences

Congruences have the following properties:

1. $a \equiv b \pmod{n}$ if $n \mid (a - b)$.
2. $a \equiv b \pmod{n}$ implies $b \equiv a \pmod{n}$.
3. $a \equiv b \pmod{n}$ and $b \equiv c \pmod{n}$ imply $a \equiv c \pmod{n}$.

To demonstrate the first point, if $n \mid (a - b)$, then $(a - b) = kn$ for some k . So we can write $a = b + kn$. Therefore, $(a \bmod n) = (\text{remainder when } b + kn \text{ is divided by } n) = (\text{remainder when } b \text{ is divided by } n) = (b \bmod n)$.

$$\begin{aligned} 23 &\equiv 8 \pmod{5} & \text{because } 23 - 8 &= 15 = 5 \times 3 \\ -11 &\equiv 5 \pmod{8} & \text{because } -11 - 5 &= -16 = 8 \times (-2) \\ 81 &\equiv 0 \pmod{27} & \text{because } 81 - 0 &= 81 = 27 \times 3 \end{aligned}$$

The remaining points are as easily proved.

²We have just used the operator *mod* in two different ways: first as a **binary operator** that produces a remainder, as in the expression $a \bmod b$; second as a **congruence relation** that shows the equivalence of two integers, as in the expression $a \equiv b \pmod{n}$. See Appendix 2A for a discussion.

Modular Arithmetic Operations

Note that, by definition (Figure 2.1), the $(\text{mod } n)$ operator maps all integers into the set of integers $\{0, 1, \dots, (n - 1)\}$. This suggests the question: Can we perform arithmetic operations within the confines of this set? It turns out that we can; this technique is known as **modular arithmetic**.

Modular arithmetic exhibits the following properties:

1. $[(a \text{ mod } n) + (b \text{ mod } n)] \text{ mod } n = (a + b) \text{ mod } n$
2. $[(a \text{ mod } n) - (b \text{ mod } n)] \text{ mod } n = (a - b) \text{ mod } n$
3. $[(a \text{ mod } n) \times (b \text{ mod } n)] \text{ mod } n = (a \times b) \text{ mod } n$

We demonstrate the first property. Define $(a \text{ mod } n) = r_a$ and $(b \text{ mod } n) = r_b$. Then we can write $a = r_a + jn$ for some integer j and $b = r_b + kn$ for some integer k . Then

$$\begin{aligned} (a + b) \text{ mod } n &= (r_a + jn + r_b + kn) \text{ mod } n \\ &= (r_a + r_b + (k + j)n) \text{ mod } n \\ &= (r_a + r_b) \text{ mod } n \\ &= [(a \text{ mod } n) + (b \text{ mod } n)] \text{ mod } n \end{aligned}$$

The remaining properties are proven as easily. Here are examples of the three properties:

$$\begin{aligned} 11 \text{ mod } 8 &= 3; 15 \text{ mod } 8 = 7 \\ [(11 \text{ mod } 8) + (15 \text{ mod } 8)] \text{ mod } 8 &= 10 \text{ mod } 8 = 2 \\ (11 + 15) \text{ mod } 8 &= 26 \text{ mod } 8 = 2 \\ [(11 \text{ mod } 8) - (15 \text{ mod } 8)] \text{ mod } 8 &= -4 \text{ mod } 8 = 4 \\ (11 - 15) \text{ mod } 8 &= -4 \text{ mod } 8 = 4 \\ [(11 \text{ mod } 8) \times (15 \text{ mod } 8)] \text{ mod } 8 &= 21 \text{ mod } 8 = 5 \\ (11 \times 15) \text{ mod } 8 &= 165 \text{ mod } 8 = 5 \end{aligned}$$

Exponentiation is performed by repeated multiplication, as in ordinary arithmetic.

To find $11^7 \text{ mod } 13$, we can proceed as follows:

$$\begin{aligned} 11^2 &= 121 \equiv 4 \pmod{13} \\ 11^4 &= (11^2)^2 \equiv 4^2 \equiv 3 \pmod{13} \\ 11^7 &= 11 \times 11^2 \times 11^4 \\ 11^7 &\equiv 11 \times 4 \times 3 \equiv 132 \equiv 2 \pmod{13} \end{aligned}$$

Thus, the rules for ordinary arithmetic involving addition, subtraction, and multiplication carry over into modular arithmetic.

Table 2.2 provides an illustration of modular addition and multiplication modulo 8. Looking at addition, the results are straightforward, and there is a regular pattern to the matrix. Both matrices are symmetric about the main diagonal in conformance to the **commutative** property of addition and multiplication. As in ordinary addition, there is an additive inverse, or negative, to each integer in modular arithmetic. In this case, the negative of an integer x is the integer y such that $(x + y) \bmod 8 = 0$. To find the additive inverse of an integer in the left-hand column, scan across the corresponding row of the matrix to find the value 0; the integer at the top of that column is the additive inverse; thus, $(2 + 6) \bmod 8 = 0$. Similarly, the entries in the multiplication table are straightforward. In modular arithmetic mod 8, the multiplicative inverse of x is the integer y such that $(x \times y) \bmod 8 = 1 \bmod 8$. Now, to find the multiplicative inverse of an integer from the multiplication table, scan across the matrix in the row for that integer to find the value 1; the integer at the top of that column is the multiplicative inverse; thus, $(3 \times 3) \bmod 8 = 1$. Note that not all integers mod 8 have a multiplicative inverse; more about that later.

Properties of Modular Arithmetic

Define the set Z_n as the set of nonnegative integers less than n :

$$Z_n = \{0, 1, \dots, (n - 1)\}$$

Table 2.2 Arithmetic Modulo 8

+	0	1	2	3	4	5	6	7
0	0	1	2	3	4	5	6	7
1	1	2	3	4	5	6	7	0
2	2	3	4	5	6	7	0	1
3	3	4	5	6	7	0	1	2
4	4	5	6	7	0	1	2	3
5	5	6	7	0	1	2	3	4
6	6	7	0	1	2	3	4	5
7	7	0	1	2	3	4	5	6

(a) Addition modulo 8

×	0	1	2	3	4	5	6	7
0	0	0	0	0	0	0	0	0
1	0	1	2	3	4	5	6	7
2	0	2	4	6	0	2	4	6
3	0	3	6	1	4	7	2	5
4	0	4	0	4	0	4	0	4
5	0	5	2	7	4	1	6	3
6	0	6	4	2	0	6	4	2
7	0	7	6	5	4	3	2	1

(b) Multiplication modulo 8

	w	$-w$	w^{-1}
0	0	0	—
1	1	7	1
2	2	6	—
3	3	5	3
4	4	4	—
5	5	3	5
6	6	2	—
7	7	1	7

(c) Additive and multiplicative inverse modulo 8

This is referred to as the **set of residues**, or **residue classes** $(\text{mod } n)$. To be more precise, each integer in Z_n represents a residue class. We can label the residue classes $(\text{mod } n)$ as $[0], [1], [2], \dots, [n - 1]$, where

$$[r] = \{a: a \text{ is an integer, } a \equiv r \pmod{n}\}$$

The residue classes $(\text{mod } 4)$ are

$$[0] = \{ \dots, -16, -12, -8, -4, 0, 4, 8, 12, 16, \dots \}$$

$$[1] = \{ \dots, -15, -11, -7, -3, 1, 5, 9, 13, 17, \dots \}$$

$$[2] = \{ \dots, -14, -10, -6, -2, 2, 6, 10, 14, 18, \dots \}$$

$$[3] = \{ \dots, -13, -9, -5, -1, 3, 7, 11, 15, 19, \dots \}$$

Of all the integers in a residue class, the smallest nonnegative integer is the one used to represent the residue class. Finding the smallest nonnegative integer to which k is congruent modulo n is called **reducing k modulo n** .

If we perform modular arithmetic within Z_n , the properties shown in Table 2.3 hold for integers in Z_n . We show in Chapter 5 that this implies that Z_n is a commutative ring with a multiplicative **identity element**.

There is one peculiarity of modular arithmetic that sets it apart from ordinary arithmetic. First, observe that (as in ordinary arithmetic) we can write the following:

$$\text{if } (a + b) \equiv (a + c) \pmod{n} \text{ then } b \equiv c \pmod{n} \quad (2.4)$$

$$(5 + 23) \equiv (5 + 7) \pmod{8}; 23 \equiv 7 \pmod{8}$$

Equation (2.4) is consistent with the existence of an additive inverse. Adding the additive inverse of a to both sides of Equation (2.4), we have

$$\begin{aligned} ((-a) + a + b) &\equiv ((-a) + a + c) \pmod{n} \\ b &\equiv c \pmod{n} \end{aligned}$$

Table 2.3 Properties of Modular Arithmetic for Integers in Z_n

Property	Expression
Commutative Laws	$(w + x) \pmod{n} = (x + w) \pmod{n}$ $(w \times x) \pmod{n} = (x \times w) \pmod{n}$
Associative Laws	$[(w + x) + y] \pmod{n} = [w + (x + y)] \pmod{n}$ $[(w \times x) \times y] \pmod{n} = [w \times (x \times y)] \pmod{n}$
Distributive Law	$[w \times (x + y)] \pmod{n} = [(w \times x) + (w \times y)] \pmod{n}$
Identities	$(0 + w) \pmod{n} = w \pmod{n}$ $(1 \times w) \pmod{n} = w \pmod{n}$
Additive Inverse $(-w)$	For each $w \in Z_n$, there exists a z such that $w + z \equiv 0 \pmod{n}$

However, the following statement is true only with the attached condition:

if $(a \times b) \equiv (a \times c) \pmod{n}$ **then** $b \equiv c \pmod{n}$ **if** a is relatively prime to n **(2.5)**

Recall that two integers are **relatively prime** if their only common positive integer factor is 1. Similar to the case of Equation (2.4), we can say that Equation (2.5) is consistent with the existence of a multiplicative inverse. Applying the multiplicative inverse of a to both sides of Equation (2.5), we have

$$\begin{aligned} ((a^{-1})ab) &\equiv ((a^{-1})ac) \pmod{n} \\ b &\equiv c \pmod{n} \end{aligned}$$

To see this, consider an example in which the condition of Equation (2.5) does not hold. The integers 6 and 8 are not relatively prime, since they have the common factor 2. We have the following:

$$6 \times 3 = 18 \equiv 2 \pmod{8}$$

$$6 \times 7 = 42 \equiv 2 \pmod{8}$$

Yet $3 \not\equiv 7 \pmod{8}$.

The reason for this strange result is that for any general modulus n , a multiplier a that is applied in turn to the integers 0 through $(n - 1)$ will fail to produce a complete set of residues if a and n have any factors in common.

With $a = 6$ and $n = 8$,

Z_8	0	1	2	3	4	5	6	7
Multiply by 6	0	6	12	18	24	30	36	42
Residues	0	6	4	2	0	6	4	2

Because we do not have a complete set of residues when multiplying by 6, more than one integer in Z_8 maps into the same residue. Specifically, $6 \times 0 \pmod{8} = 6 \times 4 \pmod{8}$; $6 \times 1 \pmod{8} = 6 \times 5 \pmod{8}$; and so on. Because this is a many-to-one mapping, there is not a unique inverse to the multiply operation.

However, if we take $a = 5$ and $n = 8$, whose only common factor is 1,

Z_8	0	1	2	3	4	5	6	7
Multiply by 5	0	5	10	15	20	25	30	35
Residues	0	5	2	7	4	1	6	3

The line of residues contains all the integers in Z_8 , in a different order.

In general, an integer has a multiplicative inverse in \mathbb{Z}_n if and only if that integer is relatively prime to n . Table 2.2c shows that the integers 1, 3, 5, and 7 have a multiplicative inverse in \mathbb{Z}_8 ; but 2, 4, and 6 do not.

Euclidean Algorithm Revisited

The Euclidean algorithm can be based on the following theorem: For any integers a , b , with $a \geq b \geq 0$,

$$\gcd(a, b) = \gcd(b, a \bmod b) \tag{2.6}$$

$$\gcd(55, 22) = \gcd(22, 55 \bmod 22) = \gcd(22, 11) = 11$$

To see that Equation (2.6) works, let $d = \gcd(a, b)$. Then, by the definition of \gcd , $d|a$ and $d|b$. For any positive integer b , we can express a as

$$\begin{aligned} a &= kb + r \equiv r \pmod{b} \\ a \bmod b &= r \end{aligned}$$

with k, r integers. Therefore, $(a \bmod b) = a - kb$ for some integer k . But because $d|b$, it also divides kb . We also have $d|a$. Therefore, $d|(a \bmod b)$. This shows that d is a common divisor of b and $(a \bmod b)$. Conversely, if d is a common divisor of b and $(a \bmod b)$, then $d|kb$ and thus $d|[kb + (a \bmod b)]$, which is equivalent to $d|a$. Thus, the set of common divisors of a and b is equal to the set of common divisors of b and $(a \bmod b)$. Therefore, the \gcd of one pair is the same as the \gcd of the other pair, proving the theorem.

Equation (2.6) can be used repetitively to determine the greatest common divisor.

$$\begin{aligned} \gcd(18, 12) &= \gcd(12, 6) = \gcd(6, 0) = 6 \\ \gcd(11, 10) &= \gcd(10, 1) = \gcd(1, 0) = 1 \end{aligned}$$

This is the same scheme shown in Equation (2.3), which can be rewritten in the following way.

Euclidean Algorithm	
Calculate	Which satisfies
$r_1 = a \bmod b$	$a = q_1b + r_1$
$r_2 = b \bmod r_1$	$b = q_2r_1 + r_2$
$r_3 = r_1 \bmod r_2$	$r_1 = q_3r_2 + r_3$
•	•
•	•
•	•
$r_n = r_{n-2} \bmod r_{n-1}$	$r_{n-2} = q_n r_{n-1} + r_n$
$r_{n+1} = r_{n-1} \bmod r_n = 0$	$r_{n-1} = q_{n+1} r_n + 0$ $d = \gcd(a, b) = r_n$

We can define the Euclidean algorithm concisely as the following recursive function.

```

Euclid(a,b)
  if (b=0) then return a;
  else return Euclid(b, a mod b);

```

The Extended Euclidean Algorithm

We now proceed to look at an extension to the Euclidean algorithm that will be important for later computations in the area of finite fields and in encryption algorithms, such as RSA. For given integers a and b , the extended Euclidean algorithm not only calculates the greatest common divisor d but also two additional integers x and y that satisfy the following equation.

$$ax + by = d = \gcd(a, b) \quad (2.7)$$

It should be clear that x and y will have opposite signs. Before examining the algorithm, let us look at some of the values of x and y when $a = 42$ and $b = 30$. Note that $\gcd(42, 30) = 6$. Here is a partial table of values³ for $42x + 30y$.

x	-3	-2	-1	0	1	2	3
y							
-3	-216	-174	-132	-90	-48	-6	36
-2	-186	-144	-102	-60	-18	24	66
-1	-156	-114	-72	-30	12	54	96
0	-126	-84	-42	0	42	84	126
1	-96	-54	-12	30	72	114	156
2	-66	-24	18	60	102	144	186
3	-36	6	48	90	132	174	216

Observe that all of the entries are divisible by 6. This is not surprising, because both 42 and 30 are divisible by 6, so every number of the form $42x + 30y = 6(7x + 5y)$ is a multiple of 6. Note also that $\gcd(42, 30) = 6$ appears in the table. In general, it can be shown that for given integers a and b , the smallest positive value of $ax + by$ is equal to $\gcd(a, b)$.

Now let us show how to extend the Euclidean algorithm to determine (x, y, d) given a and b . We again go through the sequence of divisions indicated in Equation (2.3), and we assume that at each step i we can find integers x_i and y_i that satisfy $r_i = ax_i + by_i$. We end up with the following sequence.

$$\begin{array}{ll}
 a = q_1b + r_1 & r_1 = ax_1 + by_1 \\
 b = q_2r_1 + r_2 & r_2 = ax_2 + by_2 \\
 r_1 = q_3r_2 + r_3 & r_3 = ax_3 + by_3 \\
 \vdots & \vdots \\
 r_{n-2} = q_nr_{n-1} + r_n & r_n = ax_n + by_n \\
 r_{n-1} = q_{n+1}r_n + 0 &
 \end{array}$$

³This example is taken from [SILV06].

Now, observe that we can rearrange terms to write

$$r_i = r_{i-2} - r_{i-1}q_i \tag{2.8}$$

Also, in rows $i - 1$ and $i - 2$, we find the values

$$r_{i-2} = ax_{i-2} + by_{i-2} \quad \text{and} \quad r_{i-1} = ax_{i-1} + by_{i-1}$$

Substituting into Equation (2.8), we have

$$\begin{aligned} r_i &= (ax_{i-2} + by_{i-2}) - (ax_{i-1} + by_{i-1})q_i \\ &= a(x_{i-2} - q_i x_{i-1}) + b(y_{i-2} - q_i y_{i-1}) \end{aligned}$$

But we have already assumed that $r_i = ax_i + by_i$. Therefore,

$$x_i = x_{i-2} - q_i x_{i-1} \quad \text{and} \quad y_i = y_{i-2} - q_i y_{i-1}$$

We now summarize the calculations:

Extended Euclidean Algorithm			
Calculate	Which satisfies	Calculate	Which satisfies
$r_{-1} = a$		$x_{-1} = 1; y_{-1} = 0$	$a = ax_{-1} + by_{-1}$
$r_0 = b$		$x_0 = 0; y_0 = 1$	$b = ax_0 + by_0$
$r_1 = a \bmod b$ $q_1 = \lfloor a/b \rfloor$	$a = q_1 b + r_1$	$x_1 = x_{-1} - q_1 x_0 = 1$ $y_1 = y_{-1} - q_1 y_0 = -q_1$	$r_1 = ax_1 + by_1$
$r_2 = b \bmod r_1$ $q_2 = \lfloor b/r_1 \rfloor$	$b = q_2 r_1 + r_2$	$x_2 = x_0 - q_2 x_1$ $y_2 = y_0 - q_2 y_1$	$r_2 = ax_2 + by_2$
$r_3 = r_1 \bmod r_2$ $q_3 = \lfloor r_1/r_2 \rfloor$	$r_1 = q_3 r_2 + r_3$	$x_3 = x_1 - q_3 x_2$ $y_3 = y_1 - q_3 y_2$	$r_3 = ax_3 + by_3$
• • •	• • •	• • •	• • •
$r_n = r_{n-2} \bmod r_{n-1}$ $q_n = \lfloor r_{n-2}/r_{n-1} \rfloor$	$r_{n-2} = q_n r_{n-1} + r_n$	$x_n = x_{n-2} - q_n x_{n-1}$ $y_n = y_{n-2} - q_n y_{n-1}$	$r_n = ax_n + by_n$
$r_{n+1} = r_{n-1} \bmod r_n = 0$ $q_{n+1} = \lfloor r_{n-1}/r_n \rfloor$	$r_{n-1} = q_{n+1} r_n + 0$		$d = \gcd(a, b) = r_n$ $x = x_n; y = y_n$

We need to make several additional comments here. In each row, we calculate a new remainder r_i based on the remainders of the previous two rows, namely r_{i-1} and r_{i-2} . To start the algorithm, we need values for r_0 and r_{-1} , which are just a and b . It is then straightforward to determine the required values for x_{-1}, y_{-1}, x_0 , and y_0 .

We know from the original Euclidean algorithm that the process ends with a remainder of zero and that the greatest common divisor of a and b is $d = \gcd(a, b) = r_n$. But we also have determined that $d = r_n = ax_n + by_n$. Therefore, in Equation (2.7), $x = x_n$ and $y = y_n$.

As an example, let us use $a = 1759$ and $b = 550$ and solve for $1759x + 550y = \gcd(1759, 550)$. The results are shown in Table 2.4. Thus, we have $1759 \times (-111) + 550 \times 355 = -195249 + 195250 = 1$.

Table 2.4 Extended Euclidean Algorithm Example

i	r_i	q_i	x_i	y_i
-1	1759		1	0
0	550		0	1
1	109	3	1	-3
2	5	5	-5	16
3	4	21	106	-339
4	1	1	-111	355
5	0	4		

Result: $d = 1$; $x = -111$; $y = 355$

2.4 PRIME NUMBERS⁴

A central concern of number theory is the study of prime numbers. Indeed, whole books have been written on the subject (e.g., [CRAN01], [RIBE96]). In this section, we provide an overview relevant to the concerns of this book.

An integer $p > 1$ is a **prime number** if and only if its only divisors⁵ are ± 1 and $\pm p$. All numbers other than ± 1 and the prime numbers are **composite numbers**. In other words, composite numbers are those which are the product of at least two prime numbers. Prime numbers play a critical role in number theory and in the techniques discussed in this chapter. Table 2.5 shows the primes less than 2000. Note the way the primes are distributed. In particular, note the number of primes in each range of 100 numbers.

Any integer $a > 1$ can be factored in a unique way as

$$a = p_1^{a_1} \times p_2^{a_2} \times \cdots \times p_i^{a_i} \quad (2.9)$$

where $p_1 < p_2 < \dots < p_i$ are prime numbers and where each a_i is a positive integer. This is known as the fundamental theorem of arithmetic; a proof can be found in any text on number theory.

$91 = 7 \times 13$
$3600 = 2^4 \times 3^2 \times 5^2$
$11011 = 7 \times 11^2 \times 13$

It is useful for what follows to express Equation (2.9) another way. If \mathbb{P} is the set of all prime numbers, then any positive integer a can be written uniquely in the following form:

$$a = \prod_{p \in \mathbb{P}} p^{a_p} \quad \text{where each } a_p \geq 0$$

⁴In this section, unless otherwise noted, we deal only with the nonnegative integers. The use of negative integers would introduce no essential differences.

⁵Recall from Section 2.1 that integer a is said to be a divisor of integer b if there is no remainder on division. Equivalently, we say that a divides b .

The right-hand side is the product over all possible prime numbers p ; for any particular value of a , most of the exponents a_p will be 0.

The value of any given positive integer can be specified by simply listing all the nonzero exponents in the foregoing formulation.

The integer 12 is represented by $\{a_2 = 2, a_3 = 1\}$.
 The integer 18 is represented by $\{a_2 = 1, a_3 = 2\}$.
 The integer 91 is represented by $\{a_7 = 1, a_{13} = 1\}$.

Multiplication of two numbers is equivalent to adding the corresponding exponents. Given $a = \prod_{p \in \mathbb{P}} p^{a_p}$, $b = \prod_{p \in \mathbb{P}} p^{b_p}$. Define $k = ab$. We know that the integer k can be expressed as the product of powers of primes: $k = \prod_{p \in \mathbb{P}} p^{k_p}$. It follows that $k_p = a_p + b_p$ for all $p \in \mathbb{P}$.

$$k = 12 \times 18 = (2^2 \times 3) \times (2 \times 3^2) = 216$$

$$k_2 = 2 + 1 = 3; k_3 = 1 + 2 = 3$$

$$216 = 2^3 \times 3^3 = 8 \times 27$$

What does it mean, in terms of the prime factors of a and b , to say that a divides b ? Any integer of the form p^n can be divided only by an integer that is of a lesser or equal power of the same prime number, p^j with $j \leq n$. Thus, we can say the following.

Given

$$a = \prod_{p \in \mathbb{P}} p^{a_p}, b = \prod_{p \in \mathbb{P}} p^{b_p}$$

If $a|b$, then $a_p \leq b_p$ for all p .

$$a = 12; b = 36; 12|36$$

$$12 = 2^2 \times 3; 36 = 2^2 \times 3^2$$

$$a_2 = 2 = b_2$$

$$a_3 = 1 \leq 2 = b_3$$

Thus, the inequality $a_p \leq b_p$ is satisfied for all prime numbers.

It is easy to determine the greatest common divisor of two positive integers if we express each integer as the product of primes.

$$\begin{aligned}
 300 &= 2^2 \times 3^1 \times 5^2 \\
 18 &= 2^1 \times 3^2 \\
 \gcd(18,300) &= 2^1 \times 3^1 \times 5^0 = 6
 \end{aligned}$$

The following relationship always holds:

$$\text{If } k = \gcd(a, b), \text{ then } k_p = \min(a_p, b_p) \text{ for all } p.$$

Determining the prime factors of a large number is no easy task, so the preceding relationship does not directly lead to a practical method of calculating the greatest common divisor.

2.5 FERMAT'S AND EULER'S THEOREMS

Two theorems that play important roles in public-key cryptography are Fermat's theorem and Euler's theorem.

Fermat's Theorem⁶

Fermat's theorem states the following: If p is prime and a is a positive integer not divisible by p , then

$$a^{p-1} \equiv 1 \pmod{p} \quad (2.10)$$

Proof: Consider the set of positive integers less than p : $\{1, 2, \dots, p-1\}$ and multiply each element by a , modulo p , to get the set $X = \{a \bmod p, 2a \bmod p, \dots, (p-1)a \bmod p\}$. None of the elements of X is equal to zero because p does not divide a . Furthermore, no two of the integers in X are equal. To see this, assume that $ja \equiv ka \pmod{p}$, where $1 \leq j < k \leq p-1$. Because a is relatively prime⁷ to p , we can eliminate a from both sides of the equation [see Equation (2.5)] resulting in $j \equiv k \pmod{p}$. This last equality is impossible, because j and k are both positive integers less than p . Therefore, we know that the $(p-1)$ elements of X are all positive integers with no two elements equal. We can conclude the X consists of the set of integers $\{1, 2, \dots, p-1\}$ in some order. Multiplying the numbers in both sets (p and X) and taking the result mod p yields

$$\begin{aligned}
 a \times 2a \times \cdots \times (p-1)a &\equiv [(1 \times 2 \times \cdots \times (p-1)) \pmod{p}] \\
 a^{p-1}(p-1)! &\equiv (p-1)! \pmod{p}
 \end{aligned}$$

We can cancel the $(p-1)!$ term because it is relatively prime to p [see Equation (2.5)]. This yields Equation (2.10), which completes the proof.

⁶This is sometimes referred to as Fermat's little theorem.

⁷Recall from Section 2.2 that two numbers are relatively prime if they have no prime factors in common; that is, their only common divisor is 1. This is equivalent to saying that two numbers are relatively prime if their greatest common divisor is 1.

$$\begin{aligned}
 a &= 7, p = 19 \\
 7^2 &= 49 \equiv 11 \pmod{19} \\
 7^4 &\equiv 121 \equiv 7 \pmod{19} \\
 7^8 &\equiv 49 \equiv 11 \pmod{19} \\
 7^{16} &\equiv 121 \equiv 7 \pmod{19} \\
 a^{p-1} &= 7^{18} = 7^{16} \times 7^2 \equiv 7 \times 11 \equiv 1 \pmod{19}
 \end{aligned}$$

An alternative form of Fermat's theorem is also useful: If p is prime and a is a positive integer, then

$$a^p \equiv a \pmod{p} \quad (2.11)$$

Note that the first form of the theorem [Equation (2.10)] requires that a be relatively prime to p , but this Equation (2.11) does not.

$$\begin{aligned}
 p = 5, a = 3 & \quad a^p = 3^5 = 243 \equiv 3 \pmod{5} = a \pmod{p} \\
 p = 5, a = 10 & \quad a^p = 10^5 = 100000 \equiv 10 \pmod{5} \equiv 0 \pmod{5} = a \pmod{p}
 \end{aligned}$$

Euler's Totient Function

Before presenting Euler's theorem, we need to introduce an important quantity in number theory, referred to as Euler's totient function. This function, written $\phi(n)$, is defined as the number of positive integers less than n and relatively prime to n . By convention, $\phi(1) = 1$.

Determine $\phi(37)$ and $\phi(35)$.

Because 37 is prime, all of the positive integers from 1 through 36 are relatively prime to 37. Thus $\phi(37) = 36$.

To determine $\phi(35)$, we list all of the positive integers less than 35 that are relatively prime to it:

$$\begin{aligned}
 &1, 2, 3, 4, 6, 8, 9, 11, 12, 13, 16, 17, 18 \\
 &19, 22, 23, 24, 26, 27, 29, 31, 32, 33, 34
 \end{aligned}$$

There are 24 numbers on the list, so $\phi(35) = 24$.

Table 2.6 lists the first 30 values of $\phi(n)$. The value $\phi(1)$ is without meaning but is defined to have the value 1.

It should be clear that, for a prime number p ,

$$\phi(p) = p - 1$$

Now suppose that we have two prime numbers p and q with $p \neq q$. Then we can show that, for $n = pq$,

Table 2.6 Some Values of Euler's Totient Function $\phi(n)$

n	$\phi(n)$	n	$\phi(n)$	n	$\phi(n)$
1	1	11	10	21	12
2	1	12	4	22	10
3	2	13	12	23	22
4	2	14	6	24	8
5	4	15	8	25	20
6	2	16	8	26	12
7	6	17	16	27	18
8	4	18	6	28	12
9	6	19	18	29	28
10	4	20	8	30	8

$$\phi(n) = \phi(pq) = \phi(p) \times \phi(q) = (p - 1) \times (q - 1)$$

To see that $\phi(n) = \phi(p) \times \phi(q)$, consider that the set of positive integers less than n is the set $\{1, \dots, (pq - 1)\}$. The integers in this set that are not relatively prime to n are the set $\{p, 2p, \dots, (q - 1)p\}$ and the set $\{q, 2q, \dots, (p - 1)q\}$. To see this, consider that any integer that divides n must divide either of the prime numbers p or q . Therefore, any integer that does not contain either p or q as a factor is relatively prime to n . Further note that the two sets just listed are non-overlapping: Because p and q are prime, we can state that none of the integers in the first set can be written as a multiple of q , and none of the integers in the second set can be written as a multiple of p . Thus the total number of unique integers in the two sets is $(q - 1) + (p - 1)$. Accordingly,

$$\begin{aligned} \phi(n) &= (pq - 1) - [(q - 1) + (p - 1)] \\ &= pq - (p + q) + 1 \\ &= (p - 1) \times (q - 1) \\ &= \phi(p) \times \phi(q) \end{aligned}$$

$$\begin{aligned} \phi(21) &= \phi(3) \times \phi(7) = (3 - 1) \times (7 - 1) = 2 \times 6 = 12 \\ &\text{where the 12 integers are } \{1, 2, 4, 5, 8, 10, 11, 13, 16, 17, 19, 20\}. \end{aligned}$$

Euler's Theorem

Euler's theorem states that for every a and n that are relatively prime:

$$a^{\phi(n)} \equiv 1 \pmod{n} \tag{2.12}$$

Proof: Equation (2.12) is true if n is prime, because in that case, $\phi(n) = (n - 1)$ and Fermat's theorem holds. However, it also holds for any integer n . Recall that

$\phi(n)$ is the number of positive integers less than n that are relatively prime to n . Consider the set of such integers, labeled as

$$R = \{x_1, x_2, \dots, x_{\phi(n)}\}$$

That is, each element x_i of R is a unique positive integer less than n with $\gcd(x_i, n) = 1$. Now multiply each element by a , modulo n :

$$S = \{(ax_1 \bmod n), (ax_2 \bmod n), \dots, (ax_{\phi(n)} \bmod n)\}$$

The set S is a permutation⁸ of R , by the following line of reasoning:

1. Because a is relatively prime to n and x_i is relatively prime to n , ax_i must also be relatively prime to n . Thus, all the members of S are integers that are less than n and that are relatively prime to n .
2. There are no duplicates in S . Refer to Equation (2.5). If $ax_i \bmod n = ax_j \bmod n$, then $x_i = x_j$.

Therefore,

$$\begin{aligned} \prod_{i=1}^{\phi(n)} (ax_i \bmod n) &= \prod_{i=1}^{\phi(n)} x_i \\ \prod_{i=1}^{\phi(n)} ax_i &\equiv \prod_{i=1}^{\phi(n)} x_i \pmod{n} \\ a^{\phi(n)} \times \left[\prod_{i=1}^{\phi(n)} x_i \right] &\equiv \prod_{i=1}^{\phi(n)} x_i \pmod{n} \\ a^{\phi(n)} &\equiv 1 \pmod{n} \end{aligned}$$

which completes the proof. This is the same line of reasoning applied to the proof of Fermat's theorem.

$a = 3; n = 10; \phi(10) = 4; \quad a^{\phi(n)} = 3^4 = 81 \equiv 1 \pmod{10} \equiv 1 \pmod{n}$
$a = 2; n = 11; \phi(11) = 10; \quad a^{\phi(n)} = 2^{10} = 1024 \equiv 1 \pmod{11} \equiv 1 \pmod{n}$

As is the case for Fermat's theorem, an alternative form of the theorem is also useful:

$$a^{\phi(n)+1} \equiv a \pmod{n} \tag{2.13}$$

Again, similar to the case with Fermat's theorem, the first form of Euler's theorem [Equation (2.12)] requires that a be relatively prime to n , but this form does not. It is sufficient for Equation (2.13) that n is squarefree. An integer is squarefree if its prime decomposition contains no repeated factors.

⁸A permutation of a finite set of elements S is an ordered sequence of all the elements of S , with each element appearing exactly once.

2.6 TESTING FOR PRIMALITY

For many cryptographic algorithms, it is necessary to select one or more very large prime numbers at random. Thus, we are faced with the task of determining whether a given large number is prime. There is no simple yet efficient means of accomplishing this task.

In this section, we present one attractive and popular algorithm. You may be surprised to learn that this algorithm yields a number that is not necessarily a prime. However, the algorithm can yield a number that is almost certainly a prime. This will be explained presently. We also make reference to a deterministic algorithm for finding primes. The section closes with a discussion concerning the distribution of primes.

Miller–Rabin Algorithm⁹

The algorithm due to Miller and Rabin [MILL75, RABI80] is typically used to test a large number for primality. Before explaining the algorithm, we need some background. First, any positive odd integer $n \geq 3$ can be expressed as

$$n - 1 = 2^k q \quad \text{with } k > 0, q \text{ odd}$$

To see this, note that $n - 1$ is an even integer. Then, divide $(n - 1)$ by 2 until the result is an odd number q , for a total of k divisions. If n is expressed as a binary number, then the result is achieved by shifting the number to the right until the rightmost digit is a 1, for a total of k shifts. We now develop two properties of prime numbers that we will need.

TWO PROPERTIES OF PRIME NUMBERS The **first property** is stated as follows: If p is prime and a is a positive integer less than p , then $a^2 \bmod p = 1$ if and only if either $a \bmod p = 1$ or $a \bmod p = -1 \bmod p = p - 1$. By the rules of modular arithmetic $(a \bmod p)(a \bmod p) = a^2 \bmod p$. Thus, if either $a \bmod p = 1$ or $a \bmod p = -1$, then $a^2 \bmod p = 1$. Conversely, if $a^2 \bmod p = 1$, then $(a \bmod p)^2 = 1$, which is true only for $a \bmod p = 1$ or $a \bmod p = -1$.

The **second property** is stated as follows: Let p be a prime number greater than 2. We can then write $p - 1 = 2^k q$ with $k > 0, q$ odd. Let a be any integer in the range $1 < a < p - 1$. Then one of the two following conditions is true.

1. a^q is congruent to 1 modulo p . That is, $a^q \bmod p = 1$, or equivalently, $a^q \equiv 1 \pmod{p}$.
2. One of the numbers $a^q, a^{2q}, a^{4q}, \dots, a^{2^{k-1}q}$ is congruent to -1 modulo p . That is, there is some number j in the range $(1 \leq j \leq k)$ such that $a^{2^{j-1}q} \bmod p = -1 \bmod p = p - 1$ or equivalently, $a^{2^{j-1}q} \equiv -1 \pmod{p}$.

Proof: Fermat's theorem [Equation (2.10)] states that $a^{n-1} \equiv 1 \pmod{n}$ if n is prime. We have $p - 1 = 2^k q$. Thus, we know that $a^{p-1} \bmod p = a^{2^k q} \bmod p = 1$. Thus, if we look at the sequence of numbers

$$a^q \bmod p, a^{2q} \bmod p, a^{4q} \bmod p, \dots, a^{2^{k-1}q} \bmod p, a^{2^k q} \bmod p \quad (2.14)$$

⁹Also referred to in the literature as the Rabin-Miller algorithm, or the Rabin-Miller test, or the Miller-Rabin test.

we know that the last term in Equation (2.14) has value 1. Further, each number in the list is the square of the previous number. Therefore, one of the following possibilities must be true.

1. The first number on the list, and therefore all subsequent numbers on the list, equals 1.
2. Some number on the list does not equal 1, but its square mod p does equal 1. By virtue of the first property of prime numbers defined above, we know that the only number that satisfies this condition is $p - 1$. So, in this case, the list contains an element equal to $p - 1$.

This completes the proof.

DETAILS OF THE ALGORITHM These considerations lead to the conclusion that, if n is prime, then either the first element in the list of residues, or remainders, $(a^q, a^{2q}, \dots, a^{2^{k-1}q}, a^{2^kq})$ modulo n equals 1; or some element in the list equals $(n - 1)$; otherwise n is composite (i.e., not a prime). On the other hand, if the condition is met, that does not necessarily mean that n is prime. For example, if $n = 2047 = 23 \times 89$, then $n - 1 = 2 \times 1023$. We compute $2^{1023} \bmod 2047 = 1$, so that 2047 meets the condition but is not prime.

We can use the preceding property to devise a test for primality. The procedure TEST takes a candidate integer n as input and returns the result `composite` if n is definitely not a prime, and the result `inconclusive` if n may or may not be a prime.

```

TEST (n)
1. Find integers  $k, q$ , with  $k > 0, q$  odd, so that
   ( $n - 1 = 2^k q$ );
2. Select a random integer  $a, 1 < a < n - 1$ ;
3. if  $a^q \bmod n = 1$  then return("inconclusive");
4. for  $j = 0$  to  $k - 1$  do
5. if  $a^{2^j q} \bmod n = n - 1$  then return("inconclusive");
6. return("composite");

```

Let us apply the test to the prime number $n = 29$. We have $(n - 1) = 28 = 2^2(7) = 2^k q$. First, let us try $a = 10$. We compute $10^7 \bmod 29 = 17$, which is neither 1 nor 28, so we continue the test. The next calculation finds that $(10^7)^2 \bmod 29 = 28$, and the test returns `inconclusive` (i.e., 29 may be prime). Let's try again with $a = 2$. We have the following calculations: $2^7 \bmod 29 = 12$; $2^{14} \bmod 29 = 28$; and the test again returns `inconclusive`. If we perform the test for all integers a in the range 1 through 28, we get the same `inconclusive` result, which is compatible with n being a prime number.

Now let us apply the test to the **composite number** $n = 13 \times 17 = 221$. Then $(n - 1) = 220 = 2^2(55) = 2^k q$. Let us try $a = 5$. Then we have $5^{55} \bmod 221 = 112$, which is neither 1 nor $220(5^{55})^2 \bmod 221 = 168$. Because we have used all values of j (i.e., $j = 0$ and $j = 1$) in line 4 of the TEST algorithm, the test returns `composite`, indicating that 221 is definitely a composite number. But suppose we had selected $a = 21$. Then we have $21^{55} \bmod 221 = 200$; $(21^{55})^2 \bmod 221 = 220$; and the test returns `inconclusive`, indicating that 221 may be prime. In fact, of the 218 integers from 2 through 219, four of these will return an inconclusive result, namely 21, 47, 174, and 200.

REPEATED USE OF THE MILLER–RABIN ALGORITHM How can we use the Miller–Rabin algorithm to determine with a high degree of confidence whether or not an integer is prime? It can be shown [KNUT98] that given an odd number n that is not prime and a randomly chosen integer, a with $1 < a < n - 1$, the probability that TEST will return *inconclusive* (i.e., fail to detect that n is not prime) is less than $1/4$. Thus, if t different values of a are chosen, the probability that all of them will pass TEST (return *inconclusive*) for n is less than $(1/4)^t$. For example, for $t = 10$, the probability that a nonprime number will pass all ten tests is less than 10^{-6} . Thus, for a sufficiently large value of t , we can be confident that n is prime if Miller’s test always returns *inconclusive*.

This gives us a basis for determining whether an odd integer n is prime with a reasonable degree of confidence. The procedure is as follows: Repeatedly invoke TEST (n) using randomly chosen values for a . If, at any point, TEST returns *composite*, then n is determined to be nonprime. If TEST continues to return *inconclusive* for t tests, then for a sufficiently large value of t , assume that n is prime.

A Deterministic Primality Algorithm

Prior to 2002, there was no known method of efficiently proving the primality of very large numbers. All of the algorithms in use, including the most popular (Miller–Rabin), produced a probabilistic result. In 2002 (announced in 2002, published in 2004), Agrawal, Kayal, and Saxena [AGRA04] developed a relatively simple deterministic algorithm that efficiently determines whether a given large number is a prime. The algorithm, known as the AKS algorithm, does not appear to be as efficient as the Miller–Rabin algorithm. Thus far, it has not supplanted this older, probabilistic technique.

Distribution of Primes

It is worth noting how many numbers are likely to be rejected before a prime number is found using the Miller–Rabin test, or any other test for primality. A result from number theory, known as the prime number theorem, states that the primes near n are spaced on the average one every $\ln(n)$ integers. Thus, on average, one would have to test on the order of $\ln(n)$ integers before a prime is found. Because all even integers can be immediately rejected, the correct figure is $0.5 \ln(n)$. For example, if a prime on the order of magnitude of 2^{200} were sought, then about $0.5 \ln(2^{200}) = 69$ trials would be needed to find a prime. However, this figure is just an average. In some places along the number line, primes are closely packed, and in other places there are large gaps.

The two consecutive odd integers 1,000,000,000,061 and 1,000,000,000,063 are both prime. On the other hand, $1001! + 2, 1001! + 3, \dots, 1001! + 1000, 1001! + 1001$ is a sequence of 1000 consecutive composite integers.

2.7 THE CHINESE REMAINDER THEOREM

One of the most useful results of number theory is the Chinese remainder theorem (CRT).¹⁰ In essence, the CRT says it is possible to reconstruct integers in a certain range from their residues modulo a set of pairwise relatively prime moduli.

The 10 integers in \mathbb{Z}_{10} , that is the integers 0 through 9, can be reconstructed from their two residues modulo 2 and 5 (the relatively prime factors of 10). Say the known residues of a decimal digit x are $r_2 = 0$ and $r_5 = 3$; that is, $x \bmod 2 = 0$ and $x \bmod 5 = 3$. Therefore, x is an even integer in \mathbb{Z}_{10} whose remainder, on division by 5, is 3. The unique solution is $x = 8$.

The CRT can be stated in several ways. We present here a formulation that is most useful from the point of view of this text. An alternative formulation is explored in Problem 2.33. Let

$$M = \prod_{i=1}^k m_i$$

where the m_i are pairwise relatively prime; that is, $\gcd(m_i, m_j) = 1$ for $1 \leq i, j \leq k$, and $i \neq j$. We can represent any integer A in \mathbb{Z}_M by a k -tuple whose elements are in \mathbb{Z}_{m_i} using the following correspondence:

$$A \leftrightarrow (a_1, a_2, \dots, a_k) \tag{2.15}$$

where $A \in \mathbb{Z}_M$, $a_i \in \mathbb{Z}_{m_i}$, and $a_i = A \bmod m_i$ for $1 \leq i \leq k$. The CRT makes two assertions.

1. The mapping of Equation (2.15) is a one-to-one correspondence (called a **bijection**) between \mathbb{Z}_M and the Cartesian product $\mathbb{Z}_{m_1} \times \mathbb{Z}_{m_2} \times \dots \times \mathbb{Z}_{m_k}$. That is, for every integer A such that $0 \leq A < M$, there is a unique k -tuple (a_1, a_2, \dots, a_k) with $0 \leq a_i < m_i$ that represents it, and for every such k -tuple (a_1, a_2, \dots, a_k) , there is a unique integer A in \mathbb{Z}_M .
2. Operations performed on the elements of \mathbb{Z}_M can be equivalently performed on the corresponding k -tuples by performing the operation independently in each coordinate position in the appropriate system.

Let us demonstrate the **first assertion**. The transformation from A to (a_1, a_2, \dots, a_k) , is obviously unique; that is, each a_i is uniquely calculated as $a_i = A \bmod m_i$. Computing A from (a_1, a_2, \dots, a_k) can be done as follows. Let

¹⁰The CRT is so called because it is believed to have been discovered by the Chinese mathematician Sun-Tsu in around 100 A.D.

$M_i = M/m_i$ for $1 \leq i \leq k$. Note that $M_i = m_1 \times m_2 \times \dots \times m_{i-1} \times m_{i+1} \times \dots \times m_k$, so that $M_i \equiv 0 \pmod{m_j}$ for all $j \neq i$. Then let

$$c_i = M_i \times (M_i^{-1} \pmod{m_i}) \quad \text{for } 1 \leq i \leq k \quad (2.16)$$

By the definition of M_i , it is relatively prime to m_i and therefore has a unique multiplicative inverse mod m_i . So Equation (2.16) is well defined and produces a unique value c_i . We can now compute

$$A \equiv \left(\sum_{i=1}^k a_i c_i \right) \pmod{M} \quad (2.17)$$

To show that the value of A produced by Equation (2.17) is correct, we must show that $a_i = A \pmod{m_i}$ for $1 \leq i \leq k$. Note that $c_j \equiv M_j \equiv 0 \pmod{m_i}$ if $j \neq i$, and that $c_i \equiv 1 \pmod{m_i}$. It follows that $a_i = A \pmod{m_i}$.

The **second assertion** of the CRT, concerning arithmetic operations, follows from the rules for modular arithmetic. That is, the second assertion can be stated as follows: If

$$\begin{aligned} A &\leftrightarrow (a_1, a_2, \dots, a_k) \\ B &\leftrightarrow (b_1, b_2, \dots, b_k) \end{aligned}$$

then

$$\begin{aligned} (A + B) \pmod{M} &\leftrightarrow ((a_1 + b_1) \pmod{m_1}, \dots, (a_k + b_k) \pmod{m_k}) \\ (A - B) \pmod{M} &\leftrightarrow ((a_1 - b_1) \pmod{m_1}, \dots, (a_k - b_k) \pmod{m_k}) \\ (A \times B) \pmod{M} &\leftrightarrow ((a_1 \times b_1) \pmod{m_1}, \dots, (a_k \times b_k) \pmod{m_k}) \end{aligned}$$

One of the useful features of the Chinese remainder theorem is that it provides a way to manipulate (potentially very large) numbers mod M in terms of tuples of smaller numbers. This can be useful when M is 150 digits or more. However, note that it is necessary to know beforehand the factorization of M .

To represent $973 \pmod{1813}$ as a pair of numbers mod 37 and 49, define

$$\begin{aligned} m_1 &= 37 \\ m_2 &= 49 \\ M &= 1813 \\ A &= 973 \end{aligned}$$

We also have $M_1 = 49$ and $M_2 = 37$. Using the extended Euclidean algorithm, we compute $M_1^{-1} = 34 \pmod{m_1}$ and $M_2^{-1} = 4 \pmod{m_2}$. (Note that we only need to compute each M_i and each M_i^{-1} once.) Taking residues modulo 37 and 49, our representation of 973 is $(11, 42)$, because $973 \pmod{37} = 11$ and $973 \pmod{49} = 42$.

Now suppose we want to add 678 to 973. What do we do to $(11, 42)$? First we compute $(678) \leftrightarrow (678 \pmod{37}, 678 \pmod{49}) = (12, 41)$. Then we add the tuples element-wise and reduce $(11 + 12 \pmod{37}, 42 + 41 \pmod{49}) = (23, 34)$. To verify that this has the correct effect, we compute

$$\begin{aligned}
(23, 34) &\leftrightarrow a_1 M_1 M_1^{-1} + a_2 M_2 M_2^{-1} \pmod{M} \\
&= [(23)(49)(34) + (34)(37)(4)] \pmod{1813} \\
&= 43350 \pmod{1813} \\
&= 1651
\end{aligned}$$

and check that it is equal to $(973 + 678) \pmod{1813} = 1651$. Remember that in the above derivation, M_i^{-1} is the multiplicative inverse of M_i modulo m_i and M_2^{-1} is the multiplicative inverse of M_2 modulo m_2 .

Suppose we want to multiply $1651 \pmod{1813}$ by 73. We multiply $(23, 34)$ by 73 and reduce to get $(23 \times 73 \pmod{37}, 34 \times 73 \pmod{49}) = (14, 32)$. It is easily verified that

$$\begin{aligned}
(14, 32) &\leftrightarrow [(14)(49)(34) + (32)(37)(4)] \pmod{1813} \\
&= 865 \\
&= 1651 \times 73 \pmod{1813}
\end{aligned}$$

2.8 DISCRETE LOGARITHMS

Discrete logarithms are fundamental to a number of public-key algorithms, including Diffie–Hellman key exchange and the digital signature algorithm (DSA). This section provides a brief overview of discrete logarithms. For the interested reader, more detailed developments of this topic can be found in [ORE67] and [LEVE90].

The Powers of an Integer, Modulo n

Recall from Euler’s theorem [Equation (2.12)] that, for every a and n that are relatively prime,

$$a^{\phi(n)} \equiv 1 \pmod{n}$$

where $\phi(n)$, Euler’s totient function, is the number of positive integers less than n and relatively prime to n . Now consider the more general expression:

$$a^m \equiv 1 \pmod{n} \tag{2.18}$$

If a and n are relatively prime, then there is at least one integer m that satisfies Equation (2.18), namely, $m = \phi(n)$. The least positive exponent m for which Equation (2.18) holds is referred to in several ways:

- The **order** of $a \pmod{n}$
- The exponent to which a belongs \pmod{n}
- The length of the period generated by a

To see this last point, consider the powers of 7, modulo 19:

$$\begin{aligned}
 7^1 &\equiv && 7 \pmod{19} \\
 7^2 = 49 &= 2 \times 19 + 11 &\equiv & 11 \pmod{19} \\
 7^3 = 343 &= 18 \times 19 + 1 &\equiv & 1 \pmod{19} \\
 7^4 = 2401 &= 126 \times 19 + 7 &\equiv & 7 \pmod{19} \\
 7^5 = 16807 &= 884 \times 19 + 11 &\equiv & 11 \pmod{19}
 \end{aligned}$$

There is no point in continuing because the sequence is repeating. This can be proven by noting that $7^3 \equiv 1 \pmod{19}$, and therefore, $7^{3+j} \equiv 7^3 7^j \equiv 7^j \pmod{19}$, and hence, any two powers of 7 whose exponents differ by 3 (or a multiple of 3) are congruent to each other (mod 19). In other words, the sequence is periodic, and the length of the period is the smallest positive exponent m such that $7^m \equiv 1 \pmod{19}$.

Table 2.7 shows all the powers of a , modulo 19 for all positive $a < 19$. The length of the sequence for each base value is indicated by shading. Note the following:

1. All sequences end in 1. This is consistent with the reasoning of the preceding few paragraphs.
2. The length of a sequence divides $\phi(19) = 18$. That is, an integral number of sequences occur in each row of the table.
3. Some of the sequences are of length 18. In this case, it is said that the base integer a generates (via powers) the set of nonzero integers modulo 19. Each such integer is called a primitive root of the modulus 19.

More generally, we can say that the highest possible exponent to which a number can belong (mod n) is $\phi(n)$. If a number is of this order, it is referred to as a **primitive root** of n . The importance of this notion is that if a is a primitive root of n , then its powers

$$a, a^2, \dots, a^{\phi(n)}$$

are distinct (mod n) and are all relatively prime to n . In particular, for a prime number p , if a is a primitive root of p , then

$$a, a^2, \dots, a^{p-1}$$

are distinct (mod p). For the prime number 19, its primitive roots are 2, 3, 10, 13, 14, and 15.

Not all integers have primitive roots. In fact, the only integers with primitive roots are those of the form $2, 4, p^\alpha$, and $2p^\alpha$, where p is any odd prime and α is a positive integer. The proof is not simple but can be found in many number theory books, including [ORE76].

Table 2.7 Powers of Integers, Modulo 19

a	a^2	a^3	a^4	a^5	a^6	a^7	a^8	a^9	a^{10}	a^{11}	a^{12}	a^{13}	a^{14}	a^{15}	a^{16}	a^{17}	a^{18}
1	1	1	1	1	1	1	1	1	1	1	1	1	1	1	1	1	1
2	4	8	16	13	7	14	9	18	17	15	11	3	6	12	5	10	1
3	9	8	5	15	7	2	6	18	16	10	11	14	4	12	17	13	1
4	16	7	9	17	11	6	5	1	4	16	7	9	17	11	6	5	1
5	6	11	17	9	7	16	4	1	5	6	11	17	9	7	16	4	1
6	17	7	4	5	11	9	16	1	6	17	7	4	5	11	9	16	1
7	11	1	7	11	1	7	11	1	7	11	1	7	11	1	7	11	1
8	7	18	11	12	1	8	7	18	11	12	1	8	7	18	11	12	1
9	5	7	6	16	11	4	17	1	9	5	7	6	16	11	4	17	1
10	5	12	6	3	11	15	17	18	9	14	7	13	16	8	4	2	1
11	7	1	11	7	1	11	7	1	11	7	1	11	7	1	11	7	1
12	11	18	7	8	1	12	11	18	7	8	1	12	11	18	7	8	1
13	17	12	4	14	11	10	16	18	6	2	7	15	5	8	9	3	1
14	6	8	17	10	7	3	4	18	5	13	11	2	9	12	16	15	1
15	16	12	9	2	11	13	5	18	4	3	7	10	17	8	6	14	1
16	9	11	5	4	7	17	6	1	16	9	11	5	4	7	17	6	1
17	4	11	16	6	7	5	9	1	17	4	11	16	6	7	5	9	1
18	1	18	1	18	1	18	1	18	1	18	1	18	1	18	1	18	1

Logarithms for Modular Arithmetic

With ordinary positive real numbers, the logarithm function is the inverse of exponentiation. An analogous function exists for modular arithmetic.

Let us briefly review the properties of ordinary logarithms. The logarithm of a number is defined to be the power to which some positive base (except 1) must be raised in order to equal the number. That is, for base x and for a value y ,

$$y = x^{\log_x(y)}$$

The properties of logarithms include

$$\log_x(1) = 0$$

$$\log_x(x) = 1$$

$$\log_x(yz) = \log_x(y) + \log_x(z)$$

$$\log_x(y^r) = r \times \log_x(y)$$

Consider a primitive root a for some prime number p (the argument can be developed for nonprimes as well). Then we know that the powers of a from

1 through $(p - 1)$ produce each integer from 1 through $(p - 1)$ exactly once. We also know that any integer b satisfies

$$b \equiv r \pmod{p} \text{ for some } r, \text{ where } 0 \leq r \leq (p - 1)$$

by the definition of modular arithmetic. It follows that for any integer b and a primitive root a of prime number p , we can find a unique exponent i such that

$$b \equiv a^i \pmod{p} \quad \text{where } 0 \leq i \leq (p - 1)$$

This exponent i is referred to as the **discrete logarithm** of the number b for the base $a \pmod{p}$. We denote this value as $\text{dlog}_{a,p}(b)$.¹¹

Note the following:

$$\text{dlog}_{a,p}(1) = 0 \text{ because } a^0 \pmod{p} = 1 \pmod{p} = 1$$

$$\text{dlog}_{a,p}(a) = 1 \text{ because } a^1 \pmod{p} = a$$

Here is an example using a nonprime modulus, $n = 9$. Here $\phi(n) = 6$ and $a = 2$ is a primitive root. We compute the various powers of a and find

$$\begin{aligned} 2^0 &= 1 & 2^4 &\equiv 7 \pmod{9} \\ 2^1 &= 2 & 2^5 &\equiv 5 \pmod{9} \\ 2^2 &= 4 & 2^6 &\equiv 1 \pmod{9} \\ 2^3 &= 8 \end{aligned}$$

This gives us the following table of the numbers with given discrete logarithms (mod 9) for the root $a = 2$:

Logarithm	0	1	2	3	4	5
Number	1	2	4	8	7	5

To make it easy to obtain the discrete logarithms of a given number, we rearrange the table:

Number	1	2	4	5	7	8
Logarithm	0	1	2	5	4	3

Now consider

$$\begin{aligned} x &= a^{\text{dlog}_{a,p}(x)} \pmod{p} & y &= a^{\text{dlog}_{a,p}(y)} \pmod{p} \\ xy &= a^{\text{dlog}_{a,p}(xy)} \pmod{p} \end{aligned}$$

¹¹Many texts refer to the discrete logarithm as the **index**. There is no generally agreed notation for this concept, much less an agreed name.

Using the rules of modular multiplication,

$$\begin{aligned} xy \bmod p &= [(x \bmod p)(y \bmod p)] \bmod p \\ a^{\text{dlog}_{a,p}(xy)} \bmod p &= [(a^{\text{dlog}_{a,p}(x)} \bmod p)(a^{\text{dlog}_{a,p}(y)} \bmod p)] \bmod p \\ &= (a^{\text{dlog}_{a,p}(x) + \text{dlog}_{a,p}(y)}) \bmod p \end{aligned}$$

But now consider Euler's theorem, which states that, for every a and n that are relatively prime,

$$a^{\phi(n)} \equiv 1 \pmod{n}$$

Any positive integer z can be expressed in the form $z = q + k\phi(n)$, with $0 \leq q < \phi(n)$. Therefore, by Euler's theorem,

$$a^z \equiv a^q \pmod{n} \quad \text{if } z \equiv q \pmod{\phi(n)}$$

Applying this to the foregoing equality, we have

$$\text{dlog}_{a,p}(xy) \equiv [\text{dlog}_{a,p}(x) + \text{dlog}_{a,p}(y)] \pmod{\phi(p)}$$

and generalizing,

$$\text{dlog}_{a,p}(y^r) \equiv [r \times \text{dlog}_{a,p}(y)] \pmod{\phi(p)}$$

This demonstrates the analogy between true logarithms and discrete logarithms.

Keep in mind that unique discrete logarithms mod m to some base a exist only if a is a primitive root of m .

Table 2.8, which is directly derived from Table 2.7, shows the sets of discrete logarithms that can be defined for modulus 19.

Calculation of Discrete Logarithms

Consider the equation

$$y = g^x \bmod p$$

Given g , x , and p , it is a straightforward matter to calculate y . At the worst, we must perform x repeated multiplications, and algorithms exist for achieving greater efficiency (see Chapter 9).

However, given y , g , and p , it is, in general, very difficult to calculate x (take the discrete logarithm). The difficulty seems to be on the same order of magnitude as that of factoring primes required for RSA. At the time of this writing, the asymptotically fastest known algorithm for taking discrete logarithms modulo a prime number is on the order of [BETH91]:

$$e^{((\ln p)^{1/3}(\ln(\ln p))^{2/3})}$$

which is not feasible for large primes.

Table 2.8 Tables of Discrete Logarithms, Modulo 19

(a) Discrete logarithms to the base 2, modulo 19

a	1	2	3	4	5	6	7	8	9	10	11	12	13	14	15	16	17	18
$\log_{2,19}(a)$	18	1	13	2	16	14	6	3	8	17	12	15	5	7	11	4	10	9

(b) Discrete logarithms to the base 3, modulo 19

a	1	2	3	4	5	6	7	8	9	10	11	12	13	14	15	16	17	18
$\log_{3,19}(a)$	18	7	1	14	4	8	6	3	2	11	12	15	17	13	5	10	16	9

(c) Discrete logarithms to the base 10, modulo 19

a	1	2	3	4	5	6	7	8	9	10	11	12	13	14	15	16	17	18
$\log_{10,19}(a)$	18	17	5	16	2	4	12	15	10	1	6	3	13	11	7	14	8	9

(d) Discrete logarithms to the base 13, modulo 19

a	1	2	3	4	5	6	7	8	9	10	11	12	13	14	15	16	17	18
$\log_{13,19}(a)$	18	11	17	4	14	10	12	15	16	7	6	3	1	5	13	8	2	9

(e) Discrete logarithms to the base 14, modulo 19

a	1	2	3	4	5	6	7	8	9	10	11	12	13	14	15	16	17	18
$\log_{14,19}(a)$	18	13	7	8	10	2	6	3	14	5	12	15	11	1	17	16	4	9

(f) Discrete logarithms to the base 15, modulo 19

a	1	2	3	4	5	6	7	8	9	10	11	12	13	14	15	16	17	18
$\log_{15,19}(a)$	18	5	11	10	8	16	12	15	4	13	6	3	7	17	1	2	14	9

2.9 KEY TERMS, REVIEW QUESTIONS, AND PROBLEMS

Key Terms

bijection commutative composite number discrete logarithm divisor	greatest common divisor identity element index modular arithmetic modulus	order prime number primitive root relatively prime residue
---	---	--

Review Questions

- 2.1 What does it mean to say that b is a divisor of a ?
- 2.2 What is the meaning of the expression a divides b ?
- 2.3 What is the difference between modular arithmetic and ordinary arithmetic?
- 2.4 What is a prime number?
- 2.5 What is Euler's totient function?
- 2.6 The Miller–Rabin test can determine if a number is not prime but cannot determine if a number is prime. How can such an algorithm be used to test for primality?
- 2.7 What is a primitive root of a number?
- 2.8 What is the difference between an index and a discrete logarithm?

Problems

- 2.1 Reformulate Equation (2.1), removing the restriction that a is a nonnegative integer. That is, let a be any integer.
- 2.2 Draw a figure similar to Figure 2.1 for $a < 0$.
- 2.3 For each of the following equations, find an integer x that satisfies the equation.
 - a. $4x \equiv 2 \pmod{3}$
 - b. $7x \equiv 4 \pmod{9}$
 - c. $5x \equiv 3 \pmod{11}$
- 2.4 In this text, we assume that the modulus is a positive integer. But the definition of the expression $a \bmod n$ also makes perfect sense if n is negative. Determine the following:
 - a. $7 \bmod 4$
 - b. $7 \bmod -4$
 - c. $-7 \bmod 4$
 - d. $-7 \bmod -4$
- 2.5 A modulus of 0 does not fit the definition but is defined by convention as follows: $a \bmod 0 = a$. With this definition in mind, what does the following expression mean: $a \equiv b \pmod{0}$?
- 2.6 In Section 2.3, we define the congruence relationship as follows: Two integers a and b are said to be congruent modulo n if $(a \bmod n) = (b \bmod n)$. We then proved that $a \equiv b \pmod{n}$ if $n \mid (a - b)$. Some texts on number theory use this latter relationship as the definition of congruence: Two integers a and b are said to be congruent modulo n if $n \mid (a - b)$. Using this latter definition as the starting point, prove that, if $(a \bmod n) = (b \bmod n)$, then n divides $(a - b)$.
- 2.7 What is the smallest positive integer that has exactly k divisors? Provide answers for values for $1 \leq k \leq 8$.
- 2.8 Prove the following:
 - a. $a \equiv b \pmod{n}$ implies $b \equiv a \pmod{n}$
 - b. $a \equiv b \pmod{n}$ and $b \equiv c \pmod{n}$ imply $a \equiv c \pmod{n}$
- 2.9 Prove the following:
 - a. $[(a \bmod n) - (b \bmod n)] \bmod n = (a - b) \bmod n$
 - b. $[(a \bmod n) \times (b \bmod n)] \bmod n = (a \times b) \bmod n$
- 2.10 Find the multiplicative inverse of each nonzero element in Z_5 .
- 2.11 Show that an integer N is congruent modulo 9 to the sum of its decimal digits. For example, $723 \equiv 7 + 2 + 3 \equiv 12 \equiv 1 + 2 \equiv 3 \pmod{9}$. This is the basis for the familiar procedure of “casting out 9’s” when checking computations in arithmetic.

- 2.12** a. Determine $\gcd(72345, 43215)$
 b. Determine $\gcd(3486, 10292)$
- 2.13** The purpose of this problem is to set an upper bound on the number of iterations of the Euclidean algorithm.
 a. Suppose that $m = qn + r$ with $q > 0$ and $0 \leq r < n$. Show that $m/2 > r$.
 b. Let A_i be the value of A in the Euclidean algorithm after the i th iteration. Show that

$$A_{i+2} < \frac{A_i}{2}$$

- c. Show that if m, n , and N are integers with $(1 \leq m, n, \leq 2^N)$, then the Euclidean algorithm takes at most $2N$ steps to find $\gcd(m, n)$.
- 2.14** The Euclidean algorithm has been known for over 2000 years and has always been a favorite among number theorists. After these many years, there is now a potential competitor, invented by J. Stein in 1961. Stein's algorithm is as follows: Determine $\gcd(A, B)$ with $A, B \geq 1$.

STEP 1 Set $A_1 = A, B_1 = B, C_1 = 1$

STEP 2 For $n > 1$, (1) If $A_n = B_n$, stop. $\gcd(A, B) = A_n C_n$

(2) If A_n and B_n are both even, set $A_{n+1} = A_n/2, B_{n+1} = B_n/2,$
 $C_{n+1} = 2C_n$

(3) If A_n is even and B_n is odd, set $A_{n+1} = A_n/2, B_{n+1} = B_n,$
 $C_{n+1} = C_n$

(4) If A_n is odd and B_n is even, set $A_{n+1} = A_n, B_{n+1} = B_n/2,$
 $C_{n+1} = C_n$

(5) If A_n and B_n are both odd, set $A_{n+1} = |A_n - B_n|, B_{n+1} =$
 $\min(B_n, A_n), C_{n+1} = C_n$

Continue to step $n + 1$.

- a. To get a feel for the two algorithms, compute $\gcd(6150, 704)$ using both the Euclidean and Stein's algorithm.
 b. What is the apparent advantage of Stein's algorithm over the Euclidean algorithm?
- 2.15** a. Show that if Stein's algorithm does not stop before the n th step, then

$$C_{n+1} \times \gcd(A_{n+1}, B_{n+1}) = C_n \times \gcd(A_n, B_n).$$

- b. Show that if the algorithm does not stop before step $(n - 1)$, then

$$A_{n+2} B_{n+2} \leq \frac{A_n B_n}{2}.$$

- c. Show that if $1 \leq A, B \leq 2^N$, then Stein's algorithm takes at most $4N$ steps to find $\gcd(m, n)$. Thus, Stein's algorithm works in roughly the same number of steps as the Euclidean algorithm.
 d. Demonstrate that Stein's algorithm does indeed return $\gcd(A, B)$.
- 2.16** Using the extended Euclidean algorithm, find the multiplicative inverse of
 a. $135 \pmod{61}$,
 b. $7465 \pmod{2464}$, and
 c. $42828 \pmod{6407}$.

- 2.17** The purpose of this problem is to determine how many prime numbers there are. Suppose there are a total of n prime numbers, and we list these in order: $p_1 = 2 < p_2 = 3 < p_3 = 5 < \dots < p_n$.
 a. Define $X = 1 + p_1 p_2 \dots p_n$. That is, X is equal to one plus the product of all the primes. Can we find a prime number P_m that divides X ?
 b. What can you say about m ?
 c. Deduce that the total number of primes cannot be finite.
 d. Show that $P_{n+1} \leq 1 + p_1 p_2 \dots p_n$.

- 2.18** The purpose of this problem is to demonstrate that the probability that two random numbers are relatively prime is about 0.6.
- Let $P = \Pr[\gcd(a, b) = 1]$. Show that $\Pr[\gcd(a, b) = d] = P/d^2$. *Hint:* Consider the quantity $\gcd\left(\frac{a}{d}, \frac{b}{d}\right)$.
 - The sum of the result of part (a) over all possible values of d is 1. That is $\sum_{d=1}^{\infty} \Pr[\gcd(a, b) = d] = 1$. Use this equality to determine the value of P . *Hint:* Use the identity $\sum_{i=1}^{\infty} \frac{1}{i^2} = \frac{\pi^2}{6}$.
- 2.19** Why is $\gcd(n, n + 1) = 1$ for two consecutive integers n and $n + 1$?
- 2.20** Using Fermat's theorem, find $4^{225} \bmod 13$.
- 2.21** Use Fermat's theorem to find a number a between 0 and 92 with a congruent to 7^{1013} modulo 93.
- 2.22** Use Fermat's theorem to find a number x between 0 and 37 with x^{73} congruent to 4 modulo 37. (You should not need to use any brute-force searching.)
- 2.23** Use Euler's theorem to find a number a between 0 and 9 such that a is congruent to 9^{101} modulo 10. (*Note:* This is the same as the last digit of the decimal expansion of 9^{100} .)
- 2.24** Use Euler's theorem to find a number x between 0 and 14 with x^{61} congruent to 7 modulo 15. (You should not need to use any brute-force searching.)
- 2.25** Notice in Table 2.6 that $\phi(n)$ is even for $n > 2$. This is true for all $n > 2$. Give a concise argument why this is so.
- 2.26** Prove the following: If p is prime, then $\phi(p^i) = p^i - p^{i-1}$. *Hint:* What numbers have a factor in common with p^i ?
- 2.27** It can be shown (see any book on number theory) that if $\gcd(m, n) = 1$, then $\phi(mn) = \phi(m)\phi(n)$. Using this property, the property developed in the preceding problem, and the property that $\phi(p) = p - 1$ for p prime, it is straightforward to determine the value of $\phi(n)$ for any n . Determine the following:
- $\phi(29)$
 - $\phi(51)$
 - $\phi(455)$
 - $\phi(616)$
- 2.28** It can also be shown that for arbitrary positive integer a , $\phi(a)$ is given by

$$\phi(a) = \prod_{i=1}^t [p_i^{a_i-1}(p_i - 1)]$$

where a is given by Equation (2.9), namely: $a = P_1^{a_1} P_2^{a_2} \dots P_t^{a_t}$. Demonstrate this result.

- 2.29** Consider the function: $f(n) =$ number of elements in the set $\{a: 0 \leq a < n \text{ and } \gcd(a, n) = 1\}$. What is this function?
- 2.30** Although ancient Chinese mathematicians did good work coming up with their remainder theorem, they did not always get it right. They had a test for primality. The test said that n is prime if and only if n divides $(2^n - 2)$.
- Give an example that satisfies the condition using an odd prime.
 - The condition is obviously true for $n = 2$. Prove that the condition is true if n is an odd prime (proving the **if** condition).
 - Give an example of an odd n that is not prime and that does not satisfy the condition. You can do this with nonprime numbers up to a very large value. This misled the Chinese mathematicians into thinking that if the condition is true then n is prime.
 - Unfortunately, the ancient Chinese never tried $n = 341$, which is nonprime ($341 = 11 \times 31$), yet 341 divides $2^{341} - 2$ without remainder. Demonstrate that $2341 \equiv 2 \pmod{341}$ (disproving the **only if** condition). *Hint:* It is not necessary to calculate 2^{341} ; play around with the congruences instead.

- 2.31** Show that, if n is an odd composite integer, then the Miller–Rabin test will return inconclusive for $a = 1$ and $a = (n - 1)$.
- 2.32** If n is composite and passes the Miller–Rabin test for the base a , then n is called a *strong pseudoprime to the base a* . Show that 2047 is a strong pseudoprime to the base 2.
- 2.33** A common formulation of the Chinese remainder theorem (CRT) is as follows: Let m_1, \dots, m_k be integers that are pairwise relatively prime for $1 \leq i, j \leq k$, and $i \neq j$. Define M to be the product of all the m_i 's. Let a_1, \dots, a_k be integers. Then the set of congruences:

$$\begin{aligned}x &\equiv a_1 \pmod{m_1} \\x &\equiv a_2 \pmod{m_2} \\&\cdot \\&\cdot \\x &\equiv a_k \pmod{m_k}\end{aligned}$$

has a unique solution modulo M . Show that the theorem stated in this form is true.

- 2.34** The example used by Sun-Tsu to illustrate the CRT was

$$x \equiv 2 \pmod{3}; x \equiv 3 \pmod{5}; x \equiv 2 \pmod{7}$$

Solve for x .

- 2.35** Six professors begin courses on Monday, Tuesday, Wednesday, Thursday, Friday, and Saturday, respectively, and announce their intentions of lecturing at intervals of 3, 2, 5, 6, 1, and 4 days, respectively. The regulations of the university forbid Sunday lectures (so that a Sunday lecture must be omitted). When first will all six professors find themselves compelled to omit a lecture? *Hint*: Use the CRT.
- 2.36** Find all the primitive roots of 37.
- 2.37** Given 5 as a primitive root of 23, construct a table of discrete logarithms, and use it to solve the following congruences.
- $3x^5 = 2 \pmod{23}$
 - $7x^{10} + 1 = 0 \pmod{23}$
 - $5^x = 6 \pmod{23}$

Programming Problems

- 2.1** Write a computer program that implements fast exponentiation (successive squaring) modulo n .
- 2.2** Write a computer program that implements the Miller–Rabin algorithm for a user-specified n . The program should allow the user two choices: (1) specify a possible witness a to test using the Witness procedure or (2) specify a number s of random witnesses for the Miller–Rabin test to check.

APPENDIX 2A THE MEANING OF MOD

The operator `mod` is used in this book and in the literature in two different ways: as a binary operator and as a congruence relation. This appendix explains the distinction and precisely defines the notation used in this book regarding parentheses. This notation is common but, unfortunately, not universal.

The Binary Operator mod

If a is an integer and n is a positive integer, we define $a \bmod n$ to be the remainder when a is divided by n . The integer n is called the **modulus**, and the remainder is called the **residue**. Thus, for any integer a , we can always write

$$a = \lfloor a/n \rfloor \times n + (a \bmod n)$$

Formally, we define the operator mod as

$$a \bmod n = a - \lfloor a/n \rfloor \times n \quad \text{for } n \neq 0$$

As a binary operation, mod takes two integer arguments and returns the remainder. For example, $7 \bmod 3 = 1$. The arguments may be integers, integer variables, or integer variable expressions. For example, all of the following are valid, with the obvious meanings:

$$7 \bmod 3$$

$$7 \bmod m$$

$$x \bmod 3$$

$$x \bmod m$$

$$(x^2 + y + 1) \bmod (2m + n)$$

where all of the variables are integers. For each of the above expressions, the value is the remainder that results when the left-hand term is divided by the right-hand term [see Equation (2.1)]. Note that if either the left- or right-hand argument is an expression, the expression is parenthesized. The operator mod is not inside parentheses.

In fact, the mod operation also works if the two arguments are arbitrary real numbers, not just integers. In this book, we are concerned only with the integer operation.

The Congruence Relation mod

As a congruence relation, mod expresses that two arguments have the same remainder with respect to a given modulus. For example, $7 \equiv 4 \pmod{3}$ expresses the fact that both 7 and 4 have a remainder of 1 when divided by 3. The following two expressions are equivalent:

$$a \equiv b \pmod{m} \quad \Leftrightarrow \quad a \bmod m = b \bmod m$$

Another way of expressing it is to say that the expression $a \equiv b \pmod{m}$ is the same as saying that $a - b$ is an integral multiple of m . Again, all the arguments may be integers, integer variables, or integer variable expressions. For example, all of the following are valid, with the obvious meanings:

$$7 \equiv 4 \pmod{3}$$

$$x \equiv y \pmod{m}$$

$$(x^2 + y + 1) \equiv (a + 1) \pmod{[m + n]}$$

where all of the variables are integers. Two conventions are used. The congruence sign is \equiv . The modulus for the relation is defined by placing the mod operator followed by the modulus in parentheses.

The congruence relation is used to define **residue classes**. Those numbers that have the same remainder r when divided by m form a residue class (mod m). There are m residue classes (mod m). For a given remainder r , the residue class to which it belongs consists of the numbers

$$r, r \pm m, r \pm 2m, \dots$$

According to our definition, the congruence

$$a \equiv b \pmod{m}$$

signifies that the numbers a and b differ by a multiple of m . Consequently, the congruence can also be expressed in the terms that a and b belong to the same residue class (mod m).

CLASSICAL ENCRYPTION TECHNIQUES

3.1 Symmetric Cipher Model

- Cryptography
- Cryptanalysis and Brute-Force Attack

3.2 Substitution Techniques

- Caesar Cipher
- Monoalphabetic Ciphers
- Playfair Cipher
- Hill Cipher
- Polyalphabetic Ciphers
- One-Time Pad

3.3 Transposition Techniques

3.4 Key Terms, Review Questions, and Problems

LEARNING OBJECTIVES

After studying this chapter, you should be able to:

- ◆ Present an overview of the main concepts of symmetric cryptography.
- ◆ Explain the difference between cryptanalysis and brute-force attack.
- ◆ Understand the operation of a monoalphabetic substitution cipher.
- ◆ Understand the operation of a polyalphabetic cipher.
- ◆ Present an overview of the Hill cipher.

Symmetric encryption, also referred to as **conventional encryption** or **single-key encryption**, was the only type of encryption in use prior to the development of public-key encryption in the 1970s. It remains by far the most widely used of the two types of encryption. Part Two examines a number of symmetric ciphers. In this chapter, we begin with a look at a general model for the symmetric encryption process; this will enable us to understand the context within which the algorithms are used. Next, we examine a variety of algorithms in use before the computer era. Finally, we look briefly at a different approach known as steganography. Chapters 4 and 6 introduce the two most widely used symmetric cipher: DES and AES.

Before beginning, we define some terms. An original message is known as the **plaintext**, while the coded message is called the **ciphertext**. The process of converting from plaintext to ciphertext is known as **enciphering** or **encryption**; restoring the plaintext from the ciphertext is **deciphering** or **decryption**. The many schemes used for encryption constitute the area of study known as **cryptography**. Such a scheme is known as a **cryptographic system** or a **cipher**. Techniques used for deciphering a message without any knowledge of the enciphering details fall into the area of **cryptanalysis**. Cryptanalysis is what the layperson calls “breaking the code.” The areas of cryptography and cryptanalysis together are called **cryptology**.

3.1 SYMMETRIC CIPHER MODEL

A symmetric encryption scheme has five ingredients (Figure 3.1):

- **Plaintext:** This is the original intelligible message or data that is fed into the algorithm as input.
- **Encryption algorithm:** The encryption algorithm performs various substitutions and transformations on the plaintext.
- **Secret key:** The secret key is also input to the encryption algorithm. The key is a value independent of the plaintext and of the algorithm. The algorithm will produce a different output depending on the specific key being used at the time. The exact substitutions and transformations performed by the algorithm depend on the key.

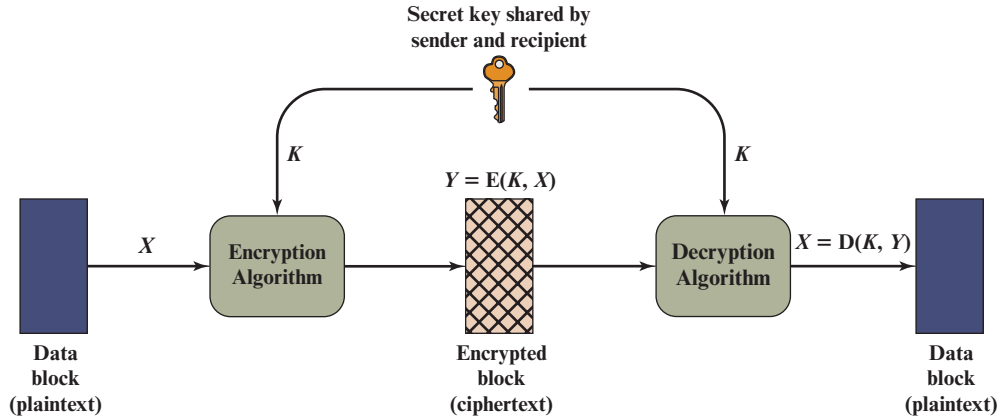

Figure 3.1 Simplified Model of Symmetric Encryption

- **Ciphertext:** This is the scrambled message produced as output. It depends on the plaintext and the secret key. For a given message, two different keys will produce two different ciphertexts. The ciphertext is an apparently random stream of data and, as it stands, is unintelligible.
- **Decryption algorithm:** This is essentially the encryption algorithm run in reverse. It takes the ciphertext and the secret key and produces the original plaintext.

There are two requirements for secure use of conventional encryption:

1. We need a strong encryption algorithm. At a minimum, we would like the algorithm to be such that an opponent who knows the algorithm and has access to one or more ciphertexts would be unable to decipher the ciphertext or figure out the key. This requirement is usually stated in a stronger form: The opponent should be unable to decrypt ciphertext or discover the key even if he or she is in possession of a number of ciphertexts together with the plaintext that produced each ciphertext.
2. Sender and receiver must have obtained copies of the secret key in a secure fashion and must keep the key secure. If someone can discover the key and knows the algorithm, all communication using this key is readable.

We assume that it is impractical to decrypt a message on the basis of the ciphertext *plus* knowledge of the encryption/decryption algorithm. In other words, we do not need to keep the algorithm secret; we need to keep only the key secret. This feature of symmetric encryption is what makes it feasible for widespread use. The fact that the algorithm need not be kept secret means that manufacturers can and have developed low-cost chip implementations of data encryption algorithms. These chips are widely available and incorporated into a number of products. With the use of symmetric encryption, the principal security problem is maintaining the secrecy of the key.

Let us take a closer look at the essential elements of a symmetric encryption scheme, using Figure 3.2. A source produces a message in plaintext, $X = [X_1, X_2, \dots, X_M]$. The M elements of X are letters in some finite alphabet. Traditionally, the alphabet usually consisted of the 26 capital letters. Nowadays,

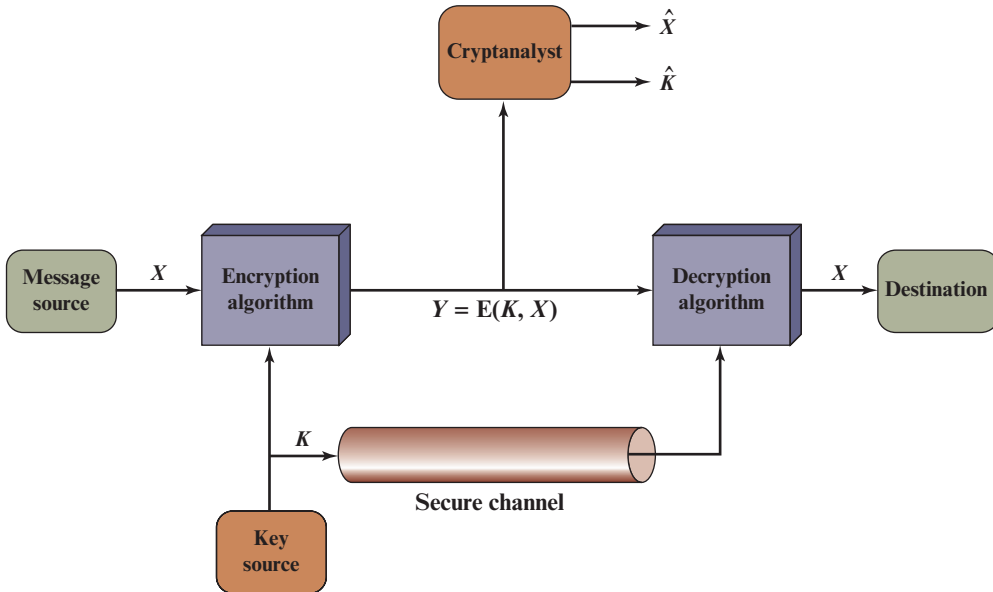

Figure 3.2 Model of Symmetric Cryptosystem

the binary alphabet $\{0, 1\}$ is typically used. For encryption, a key of the form $K = [K_1, K_2, \dots, K_j]$ is generated. If the key is generated at the message source, then it must also be provided to the destination by means of some secure channel. Alternatively, a third party could generate the key and securely deliver it to both source and destination.

With the message X and the encryption key K as input, the encryption algorithm forms the ciphertext $Y = [Y_1, Y_2, \dots, Y_N]$. We can write this as

$$Y = E(K, X)$$

This notation indicates that Y is produced by using encryption algorithm E as a function of the plaintext X , with the specific function determined by the value of the key K .

The intended receiver, in possession of the key, is able to invert the transformation:

$$X = D(K, Y)$$

An opponent, observing Y but not having access to K or X , may attempt to recover X or K or both X and K . It is assumed that the opponent knows the encryption (E) and decryption (D) algorithms. If the opponent is interested in only this particular message, then the focus of the effort is to recover X by generating a plaintext estimate \hat{X} . Often, however, the opponent is interested in being able to read future messages as well, in which case an attempt is made to recover K by generating an estimate \hat{K} .

Cryptography

Cryptographic systems are characterized along three independent dimensions:

1. **The type of operations used for transforming plaintext to ciphertext.** All encryption algorithms are based on two general principles: substitution, in which each element in the plaintext (bit, letter, group of bits or letters) is mapped into another element, and transposition, in which elements in the plaintext are rearranged. The fundamental requirement is that no information be lost (i.e., that all operations are reversible). Most systems, referred to as *product systems*, involve multiple stages of substitutions and transpositions.
2. **The number of keys used.** If both sender and receiver use the same key, the system is referred to as symmetric, single-key, secret-key, or conventional encryption. If the sender and receiver use different keys, the system is referred to as asymmetric, two-key, or public-key encryption.
3. **The way in which the plaintext is processed.** A **block cipher** processes the input one block of elements at a time, producing an output block for each input block. A **stream cipher** processes the input elements continuously, producing output one element at a time, as it goes along.

Cryptanalysis and Brute-Force Attack

Typically, the objective of attacking an encryption system is to recover the key in use rather than simply to recover the plaintext of a single ciphertext. There are two general approaches to attacking a conventional encryption scheme:

- **Cryptanalysis:** Cryptanalytic attacks rely on the nature of the algorithm plus perhaps some knowledge of the general characteristics of the plaintext or even some sample plaintext–ciphertext pairs. This type of attack exploits the characteristics of the algorithm to attempt to deduce a specific plaintext or to deduce the key being used.
- **Brute-force attack:** The attacker tries every possible key on a piece of ciphertext until an intelligible translation into plaintext is obtained. On average, half of all possible keys must be tried to achieve success.

If either type of attack succeeds in deducing the key, the effect is catastrophic: All future and past messages encrypted with that key are compromised.

CRYPTANALYSIS Table 3.1 summarizes the various types of **cryptanalytic attacks** based on the amount of information known to the cryptanalyst. The most difficult problem is presented when all that is available is the *ciphertext only*. In some cases, not even the encryption algorithm is known, but in general, we can assume that the opponent does know the algorithm used for encryption. One possible attack under these circumstances is the brute-force approach of trying all possible keys. If the key space is very large, this becomes impractical. Thus, the opponent must rely on an analysis of the ciphertext itself, generally applying various statistical tests to it. To use this approach, the opponent must have some general idea of the type of plaintext that is concealed, such as English or French text, an EXE file, a Java source listing, an accounting file, and so on.

Table 3.1 Types of Attacks on Encrypted Messages

Type of Attack	Known to Cryptanalyst
Ciphertext Only	<ul style="list-style-type: none"> ■ Encryption algorithm ■ Ciphertext
Known Plaintext	<ul style="list-style-type: none"> ■ Encryption algorithm ■ Ciphertext ■ One or more plaintext–ciphertext pairs formed with the secret key
Chosen Plaintext	<ul style="list-style-type: none"> ■ Encryption algorithm ■ Ciphertext ■ Plaintext message chosen by cryptanalyst, together with its corresponding ciphertext generated with the secret key
Chosen Ciphertext	<ul style="list-style-type: none"> ■ Encryption algorithm ■ Ciphertext ■ Ciphertext chosen by cryptanalyst, together with its corresponding decrypted plaintext generated with the secret key
Chosen Text	<ul style="list-style-type: none"> ■ Encryption algorithm ■ Ciphertext ■ Plaintext message chosen by cryptanalyst, together with its corresponding ciphertext generated with the secret key ■ Ciphertext chosen by cryptanalyst, together with its corresponding decrypted plaintext generated with the secret key

The ciphertext-only attack is the easiest to defend against because the opponent has the least amount of information to work with. In many cases, however, the analyst has more information. The analyst may be able to capture one or more plaintext messages as well as their encryptions. Or the analyst may know that certain plaintext patterns will appear in a message. For example, a file that is encoded in the Postscript format always begins with the same pattern, or there may be a standardized header or banner to an electronic funds transfer message, and so on. All these are examples of *known plaintext*. With this knowledge, the analyst may be able to deduce the key on the basis of the way in which the known plaintext is transformed.

Closely related to the known-plaintext attack is what might be referred to as a probable-word attack. If the opponent is working with the encryption of some general prose message, he or she may have little knowledge of what is in the message. However, if the opponent is after some very specific information, then parts of the message may be known. For example, if an entire accounting file is being transmitted, the opponent may know the placement of certain key words in the header of the file. As another example, the source code for a program developed by Corporation X might include a copyright statement in some standardized position.

If the analyst is able somehow to get the source system to insert into the system a message chosen by the analyst, then a *chosen-plaintext* attack is possible. In general, if the analyst is able to choose the messages to encrypt, the analyst may deliberately pick patterns that can be expected to reveal the structure of the key.

Table 3.1 lists two other types of attack: chosen ciphertext and chosen text. These are less commonly employed as cryptanalytic techniques but are nevertheless possible avenues of attack.

Only relatively weak algorithms fail to withstand a ciphertext-only attack. Generally, an encryption algorithm is designed to withstand a known-plaintext attack.

Two more definitions are worthy of note. An encryption scheme is **unconditionally secure** if the ciphertext generated by the scheme does not contain enough information to determine uniquely the corresponding plaintext, no matter how much ciphertext is available. That is, no matter how much time an opponent has, it is impossible for him or her to decrypt the ciphertext simply because the required information is not there. With the exception of a scheme known as the one-time pad (described later in this chapter), there is no encryption algorithm that is unconditionally secure. Therefore, all that the users of an encryption algorithm can strive for is an algorithm that meets one or both of the following criteria:

- The cost of breaking the cipher exceeds the value of the encrypted information.
- The time required to break the cipher exceeds the useful lifetime of the information.

An encryption scheme is said to be **computationally secure** if either of the foregoing two criteria are met. Unfortunately, it is very difficult to estimate the amount of effort required to cryptanalyze ciphertext successfully.

All forms of cryptanalysis for symmetric encryption schemes are designed to exploit the fact that traces of structure or pattern in the plaintext may survive encryption and be discernible in the ciphertext. This will become clear as we examine various symmetric encryption schemes in this chapter. We will see in Part Three that cryptanalysis for public-key schemes proceeds from a fundamentally different premise, namely, that the mathematical properties of the pair of keys may make it possible for one of the two keys to be deduced from the other.

BRUTE-FORCE ATTACK A **brute-force attack** involves trying every possible key until an intelligible translation of the ciphertext into plaintext is obtained. On average, half of all possible keys must be tried to achieve success. That is, if there are X different keys, on average an attacker would discover the actual key after $X/2$ tries. It is important to note that there is more to a brute-force attack than simply running through all possible keys. Unless known plaintext is provided, the analyst must be able to recognize plaintext as plaintext. If the message is just plain text in English, then the result pops out easily, although the task of recognizing English would have to be automated. If the text message has been compressed before encryption, then recognition is more difficult. And if the message is some more general type of data, such as a numerical file, and this has been compressed, the problem becomes even more difficult to automate. Thus, to supplement the brute-force approach, some degree of knowledge about the expected plaintext is needed, and some means of automatically distinguishing plaintext from garble is also needed.

STRONG ENCRYPTION For users, security managers, and organization executives, there is a requirement for strong encryption to protect data. The term *strong encryption* is an imprecise one, but in general terms, it refers to encryption schemes that make it impractically difficult for unauthorized persons or systems to gain access to plaintext that has been encrypted. [NAS18] lists the following properties that make an encryption algorithm strong: appropriate choice of cryptographic algorithm, use of sufficiently long key lengths, appropriate choice of protocols, a well-engineered implementation, and the absence of deliberately introduced hidden flaws. The first two factors relate to cryptanalysis, discussed in this section, and the third factor relates to the discussion in Part Six. The last two factors are beyond the scope of this book.

3.2 SUBSTITUTION TECHNIQUES

In this section and the next, we examine a sampling of what might be called classical encryption techniques. A study of these techniques enables us to illustrate the basic approaches to symmetric encryption used today and the types of cryptanalytic attacks that must be anticipated.

The two basic building blocks of all encryption techniques are substitution and transposition. We examine these in the next two sections. Finally, we discuss a system that combines both substitution and transposition.

A substitution technique is one in which the letters of plaintext are replaced by other letters or by numbers or symbols.¹ If the plaintext is viewed as a sequence of bits, then substitution involves replacing plaintext bit patterns with ciphertext bit patterns.

Caesar Cipher

The earliest known, and the simplest, use of a substitution cipher was by Julius Caesar. The Caesar cipher involves replacing each letter of the alphabet with the letter standing three places further down the alphabet. For example,

```
plain: meet me after the toga party
cipher: PHHW PH DIWHU WKH WRJD SDUWB
```

Note that the alphabet is wrapped around, so that the letter following Z is A. We can define the transformation by listing all possibilities, as follows:

```
plain: a b c d e f g h i j k l m n o p q r s t u v w x y z
cipher: D E F G H I J K L M N O P Q R S T U V W X Y Z A B C
```

Let us assign a numerical equivalent to each letter:

a	b	c	d	e	f	g	h	i	j	k	l	m
0	1	2	3	4	5	6	7	8	9	10	11	12

n	o	p	q	r	s	t	u	v	w	x	y	z
13	14	15	16	17	18	19	20	21	22	23	24	25

Then the algorithm can be expressed as follows. For each plaintext letter p , substitute the ciphertext letter C :²

$$C = E(3, p) = (p + 3) \bmod 26$$

A shift may be of any amount, so that the general Caesar algorithm is

$$C = E(k, p) = (p + k) \bmod 26 \quad (3.1)$$

¹When letters are involved, the following conventions are used in this book. Plaintext is always in lowercase; ciphertext is in uppercase; key values are in italicized lowercase.

²We define $a \bmod n$ to be the remainder when a is divided by n . For example, $11 \bmod 7 = 4$. See Chapter 2 for a further discussion of modular arithmetic.

where k takes on a value in the range 1 to 25. The decryption algorithm is simply

$$p = D(k, C) = (C - k) \bmod 26 \quad (3.2)$$

If it is known that a given ciphertext is a Caesar cipher, then a brute-force cryptanalysis is easily performed: simply try all the 25 possible keys. Figure 3.3 shows the results of applying this strategy to the example ciphertext. In this case, the plaintext leaps out as occupying the third line.

Three important characteristics of this problem enabled us to use a brute-force cryptanalysis:

1. The encryption and decryption algorithms are known.
2. There are only 25 keys to try.
3. The language of the plaintext is known and easily recognizable.

In most networking situations, we can assume that the algorithms are known. What generally makes brute-force cryptanalysis impractical is the use of an algorithm that employs a large number of keys. For example, the triple DES algorithm,

KEY	PHHW	PH	DIWHU	WKH	WRJD	SDUWB
1	oggv	og	chvgt	vjg	vqic	rctva
2	nffu	nf	bgufs	uif	uphb	qbsuz
3	meet	me	after	the	toga	party
4	ldds	ld	zesdq	sgd	snfz	ozqsx
5	kccr	kc	ydrpc	rfc	rmey	nyprw
6	jbbq	jb	xcqbo	qeb	qldx	mxoqv
7	iaap	ia	wbpan	pda	pkcw	lwnpu
8	hzzo	hz	vaozm	ocz	objv	kvmot
9	gyyn	gy	uznyl	nby	niau	julns
10	fxxm	fx	tymxk	max	mhzt	itkmr
11	ewwl	ew	sxlwj	lzw	lgys	hsjql
12	dvvk	dv	rwkvi	kyv	kfxr	grikp
13	cuuj	cu	qvjuh	jxu	jewq	fqhjo
14	btti	bt	puitg	iwt	idvp	epgin
15	assh	as	othsf	hvs	hcuo	dofhm
16	zrrg	zr	nsgre	gur	gbtn	cnegl
17	yqqf	yq	mrfqd	ftq	fasm	bmdfk
18	xppe	xp	lqepc	esp	ezrl	alcej
19	wood	wo	kpdob	dro	dyqk	zkbdi
20	vnnc	vn	jocna	cqn	cxpj	yjach
21	ummb	um	inbmz	bpm	bwoi	xizbg
22	tlla	tl	hmaly	aol	avnh	whyaf
23	skkz	sk	glzxx	znk	zumg	vgxze
24	rjyy	rj	fkyjw	ymj	ytlf	ufwyd
25	qiix	qi	ejxiv	xli	xske	tevxc

Figure 3.3 Brute-Force Cryptanalysis of Caesar Cipher

```

~+Wu"- Ω-O)≤4{∞‡, ë-Ω%ràu·-í ◇-Z-
Ú≠2Ô#Åæð æ«q7,Ωn·@3NÔÛ ÇZ'Y-f∞Í[±Û_ èΩ,<NO-±«~xã Åäfèü3Å
x)ö§k°Å
_yí ^ΔÉ] ,¼ J/°iTê&1 'c<uΩ-
ÄD(G WÄC~y_iöÄW PÔ1«îÛ†ç],¼j ~î^úÑπ~≈~L~9OgflO~&æ≤ ~≤ ∅Ô§":
~Ç!SGqèvo^ ú\,S>h<-*6ø‡%x'~|fió#≈~my%~≥ñP<,fi Áj Å∅¿"Zù-
Ω~Ö-6Çÿ{% „ΩÉó ,i π+Âî°úO2çSÿ'Ö-
2Äflßi /e^"ΠK°ªPÇπ,úé^~3Σ~ð~ÔZÌ"Y-ÿΩæY> Ω+eô/·<Kf¿*+~"≤ú~
B ZøK~Qßÿüf ,!òflîzss/]>ÈQ ü

```

Figure 3.4 Sample of Compressed Text

examined in Chapter 7, makes use of a 168-bit key, giving a key space of 2^{168} or greater than 3.7×10^{50} possible keys.

The third characteristic is also significant. If the language of the plaintext is unknown, then plaintext output may not be recognizable. Furthermore, the input may be abbreviated or compressed in some fashion, again making recognition difficult. For example, Figure 3.4 shows a portion of a text file compressed using an algorithm called ZIP. If this file is then encrypted with a simple substitution cipher (expanded to include more than just 26 alphabetic characters), then the plaintext may not be recognized when it is uncovered in the brute-force cryptanalysis.

Monoalphabetic Ciphers

With only 25 possible keys, the Caesar cipher is far from secure. A dramatic increase in the key space can be achieved by allowing an arbitrary substitution. Before proceeding, we define the term *permutation*. A **permutation** of a finite set of elements S is an ordered sequence of all the elements of S , with each element appearing exactly once. For example, if $S = \{a, b, c\}$, there are six permutations of S :

abc, acb, bac, bca, cab, cba

In general, there are $n!$ permutations of a set of n elements, because the first element can be chosen in one of n ways, the second in $n - 1$ ways, the third in $n - 2$ ways, and so on.

Recall the assignment for the Caesar cipher:

```

plain:  a b c d e f g h i j k l m n o p q r s t u v w x y z
cipher: D E F G H I J K L M N O P Q R S T U V W X Y Z A B C

```

If, instead, the “cipher” line can be any permutation of the 26 alphabetic characters, then there are $26!$ or greater than 4×10^{26} possible keys. This is 10 orders of magnitude greater than the key space for DES and would seem to eliminate brute-force techniques for cryptanalysis. Such an approach is referred to as a **monoalphabetic substitution cipher**, because a single cipher alphabet (mapping from plain alphabet to cipher alphabet) is used per message.

There is, however, another line of attack. If the cryptanalyst knows the nature of the plaintext (e.g., noncompressed English text), then the analyst can exploit the regularities of the language. To see how such a cryptanalysis might proceed, we give a partial example here that is adapted from one in [SINK09]. The ciphertext to be solved is

UZQSOVUOHXMOPVGPOZPEVSGZWSZOPFPESXUDBMETSXAIZ
 VUEPHZHMDZSHZOWSFPAPPDTSVPPQUZWMYXUZUHSX
 EPYEPOPDZSZUFPOMBZWPFUPZHMDJUDTMOHMQ

As a first step, the relative frequency of the letters can be determined and compared to a standard frequency distribution for English, such as is shown in Figure 3.5 (based on [LEWA00]). If the message were long enough, this technique alone might be sufficient, but because this is a relatively short message, we cannot expect an exact match. In any case, the relative frequencies of the letters in the ciphertext (in percentages) are as follows:

P	13.33	H	5.83	F	3.33	B	1.67	C	0.00
Z	11.67	D	5.00	W	3.33	G	1.67	K	0.00
S	8.33	E	5.00	Q	2.50	Y	1.67	L	0.00
U	8.33	V	4.17	T	2.50	I	0.83	N	0.00
O	7.50	X	4.17	A	1.67	J	0.83	R	0.00
M	6.67								

Comparing this breakdown with Figure 3.5, it seems likely that cipher letters P and Z are the equivalents of plain letters e and t, but it is not certain which is which. The letters S, U, O, M, and H are all of relatively high frequency and probably

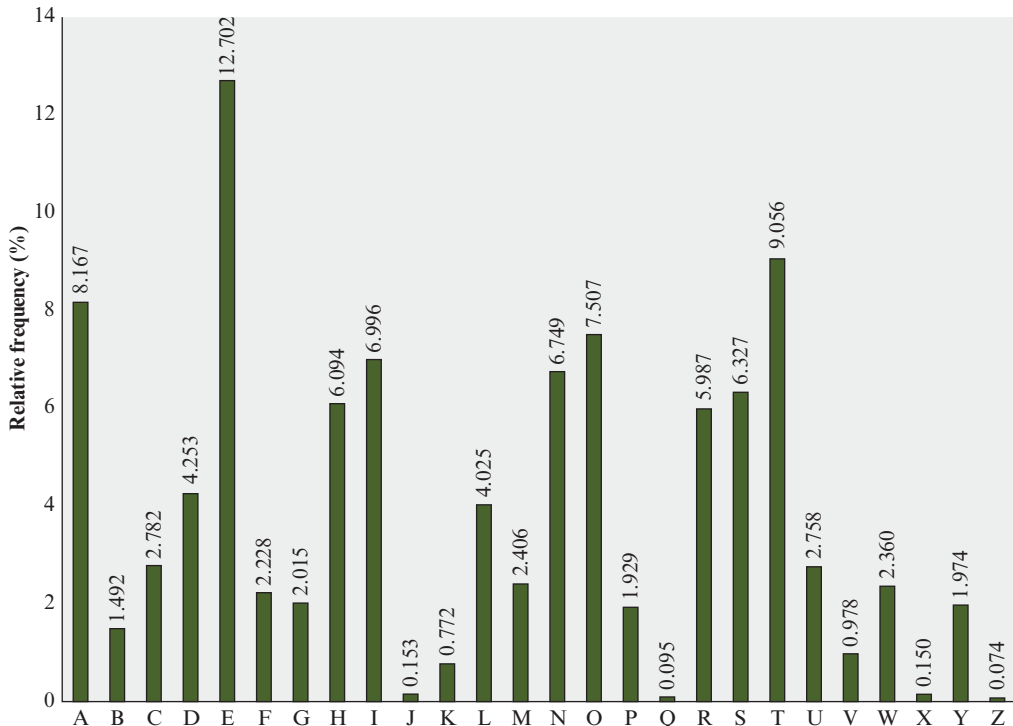

Figure 3.5 Relative Frequency of Letters in English Text

correspond to plain letters from the set {a, h, i, n, o, r, s}. The letters with the lowest frequencies (namely, A, B, G, Y, I, J) are likely included in the set {b, j, k, q, v, x, z}.

There are a number of ways to proceed at this point. We could make some tentative assignments and start to fill in the plaintext to see if it looks like a reasonable “skeleton” of a message. A more systematic approach is to look for other regularities. For example, certain words may be known to be in the text. Or we could look for repeating sequences of cipher letters and try to deduce their plaintext equivalents.

A powerful tool is to look at the frequency of two-letter combinations, known as **digrams**. A table similar to Figure 3.5 could be drawn up showing the relative frequency of digrams. The most common such digram is th. In our ciphertext, the most common digram is ZW, which appears three times. So we make the correspondence of Z with t and W with h. Then, by our earlier hypothesis, we can equate P with e. Now notice that the sequence ZWP appears in the ciphertext, and we can translate that sequence as “the.” This is the most frequent trigram (three-letter combination) in English, which seems to indicate that we are on the right track.

Next, notice the sequence ZWSZ in the first line. We do not know that these four letters form a complete word, but if they do, it is of the form th_t. If so, S equates with a.

So far, then, we have

```

UZQSOVUOHXMOPVGPQZPEVSGZWSZOPFPESXUDBMETSXAIZ
  t a           e e t e a t h a t e e a           a
VUEPHZHMDSHZOWSFPAPPDTSVPQUZWMYXUZUHSX
  e t   t a t h a e e e a e t h   t a
EPYEPPOPDZSZUFPOMBZWPFPUPZHMDJUDTMOHMQ
  e e e t a t e   t h e   t

```

Only four letters have been identified, but already we have quite a bit of the message. Continued analysis of frequencies plus trial and error should easily yield a solution from this point. The complete plaintext, with spaces added between words, follows:

```

it was disclosed yesterday that several informal but
direct contacts have been made with political
representatives of the viet cong in moscow

```

Monoalphabetic ciphers are easy to break because they reflect the frequency data of the original alphabet. A countermeasure is to provide multiple substitutes, known as homophones, for a single letter. For example, the letter e could be assigned a number of different cipher symbols, such as 16, 74, 35, and 21, with each homophone assigned to a letter in rotation or randomly. If the number of symbols assigned to each letter is proportional to the relative frequency of that letter, then single-letter frequency information is completely obliterated. The great mathematician Carl Friedrich Gauss believed that he had devised an unbreakable cipher using homophones. However, even with homophones, each element of plaintext affects only one element of ciphertext, and multiple-letter patterns

(e.g., digram frequencies) still survive in the ciphertext, making cryptanalysis relatively straightforward.

Two principal methods are used in substitution ciphers to lessen the extent to which the structure of the plaintext survives in the ciphertext: One approach is to encrypt multiple letters of plaintext, and the other is to use multiple cipher alphabets. We briefly examine each.

Playfair Cipher

The best-known multiple-letter encryption cipher is the Playfair, which treats digrams in the plaintext as single units and translates these units into ciphertext digrams.³

The Playfair algorithm is based on the use of a 5×5 matrix of letters constructed using a keyword. Here is an example, solved by Lord Peter Wimsey in Dorothy Sayers's *Have His Carcase*.⁴

M	O	N	A	R
C	H	Y	B	D
E	F	G	I/J	K
L	P	Q	S	T
U	V	W	X	Z

In this case, the keyword is *monarchy*. The matrix is constructed by filling in the letters of the keyword (minus duplicates) from left to right and from top to bottom, and then filling in the remainder of the matrix with the remaining letters in alphabetic order. The letters I and J count as one letter. Plaintext is encrypted two letters at a time, according to the following rules:

1. Repeating plaintext letters that are in the same pair are separated with a filler letter, such as x, so that balloon would be treated as ba lx lo on.
2. Two plaintext letters that fall in the same row of the matrix are each replaced by the letter to the right, with the first element of the row circularly following the last. For example, ar is encrypted as RM.
3. Two plaintext letters that fall in the same column are each replaced by the letter beneath, with the top element of the column circularly following the last. For example, mu is encrypted as CM.
4. Otherwise, each plaintext letter in a pair is replaced by the letter that lies in its own row and the column occupied by the other plaintext letter. Thus, hs becomes BP and ea becomes IM (or JM, as the encipherer wishes).

The Playfair cipher is a great advance over simple monoalphabetic ciphers. For one thing, whereas there are only 26 letters, there are $26 \times 26 = 676$ digrams, so

³This cipher was actually invented by British scientist Sir Charles Wheatstone in 1854, but it bears the name of his friend Baron Playfair of St. Andrews, who championed the cipher at the British foreign office.

⁴The book provides an absorbing account of a probable-word attack.

that identification of individual digrams is more difficult. Furthermore, the relative frequencies of individual letters exhibit a much greater range than that of digrams, making frequency analysis much more difficult. For these reasons, the Playfair cipher was for a long time considered unbreakable. It was used as the standard field system by the British Army in World War I and still enjoyed considerable use by the U.S. Army and other Allied forces during World War II.

Despite this level of confidence in its security, the Playfair cipher is relatively easy to break, because it still leaves much of the structure of the plaintext language intact. A few hundred letters of ciphertext are generally sufficient.

One way of revealing the effectiveness of the Playfair and other ciphers is shown in Figure 3.6. The line labeled *plaintext* plots a typical frequency distribution of the 26 alphabetic characters (no distinction between upper and lower case) in ordinary text. This is also the frequency distribution of any monoalphabetic substitution cipher, because the frequency values for individual letters are the same, just with different letters substituted for the original letters. The plot is developed in the following way: The number of occurrences of each letter in the text is counted and divided by the number of occurrences of the most frequently used letter. Using the results of Figure 3.5, we see that *e* is the most frequently used letter. As a result, *e* has a relative frequency of 1, *t* of $9.056/12.702 \approx 0.72$, and so on. The points on the horizontal axis correspond to the letters in order of decreasing frequency.

Figure 3.6 also shows the frequency distribution that results when the text is encrypted using the Playfair cipher. To normalize the plot, the number of occurrences of each letter in the ciphertext was again divided by the number of occurrences of *e* in the plaintext. The resulting plot therefore shows the extent to which the frequency distribution of letters, which makes it trivial to solve substitution

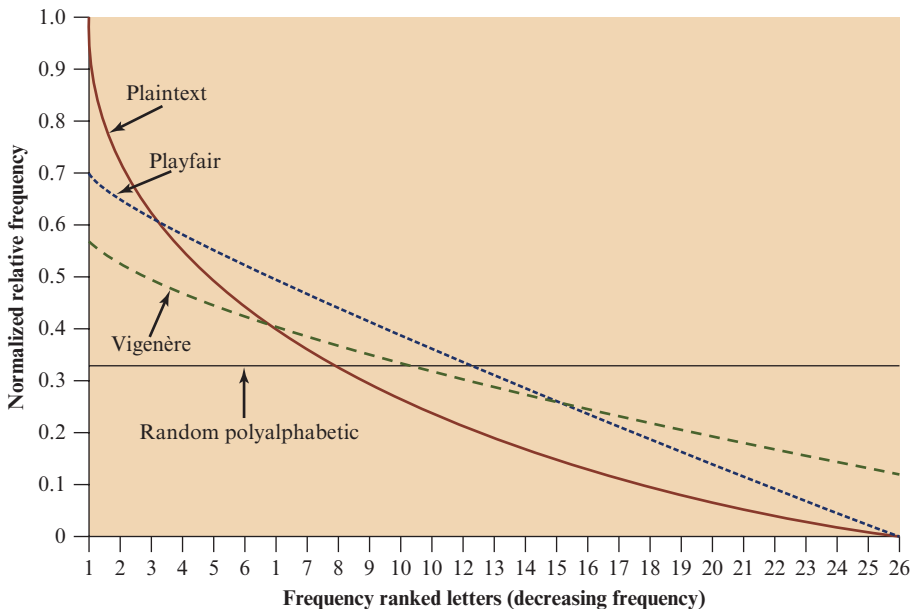

Figure 3.6 Relative Frequency of Occurrence of Letters

ciphers, is masked by encryption. If the frequency distribution information were totally concealed in the encryption process, the ciphertext plot of frequencies would be flat, and cryptanalysis using ciphertext only would be effectively impossible. As the figure shows, the Playfair cipher has a flatter distribution than does plaintext, but nevertheless, it reveals plenty of structure for a cryptanalyst to work with. The plot also shows the Vigenère cipher, discussed subsequently. The Hill and Vigenère curves on the plot are based on results reported in [SIMM93].

Hill Cipher⁵

Another interesting multiletter cipher is the Hill cipher, developed by the mathematician Lester Hill in 1929.

CONCEPTS FROM LINEAR ALGEBRA Before describing the Hill cipher, let us briefly review some terminology from linear algebra. In this discussion, we are concerned with matrix arithmetic modulo 26. For the reader who needs a refresher on matrix multiplication and inversion, see Appendix A.

We define the inverse \mathbf{M}^{-1} of a square matrix \mathbf{M} by the equation $\mathbf{M}(\mathbf{M}^{-1}) = \mathbf{M}^{-1}\mathbf{M} = \mathbf{I}$, where \mathbf{I} is the identity matrix. \mathbf{I} is a square matrix that is all zeros except for ones along the main diagonal from upper left to lower right. The inverse of a matrix does not always exist, but when it does, it satisfies the preceding equation. For example,

$$\begin{aligned}\mathbf{A} &= \begin{pmatrix} 5 & 8 \\ 17 & 3 \end{pmatrix} & \mathbf{A}^{-1} \bmod 26 &= \begin{pmatrix} 9 & 2 \\ 1 & 15 \end{pmatrix} \\ \mathbf{A}\mathbf{A}^{-1} &= \begin{pmatrix} (5 \times 9) + (8 \times 1) & (5 \times 2) + (8 \times 15) \\ (17 \times 9) + (3 \times 1) & (17 \times 2) + (3 \times 15) \end{pmatrix} \\ &= \begin{pmatrix} 53 & 130 \\ 156 & 79 \end{pmatrix} \bmod 26 = \begin{pmatrix} 1 & 0 \\ 0 & 1 \end{pmatrix}\end{aligned}$$

To explain how the inverse of a matrix is computed, we begin with the concept of determinant. For any square matrix ($m \times m$), the **determinant** equals the sum of all the products that can be formed by taking exactly one element from each row and exactly one element from each column, with certain of the product terms preceded by a minus sign. For a 2×2 matrix,

$$\begin{pmatrix} k_{11} & k_{12} \\ k_{21} & k_{22} \end{pmatrix}$$

the determinant is $k_{11}k_{22} - k_{12}k_{21}$. For a 3×3 matrix, the value of the determinant is $k_{11}k_{22}k_{33} + k_{21}k_{32}k_{13} + k_{31}k_{12}k_{23} - k_{31}k_{22}k_{13} - k_{21}k_{12}k_{33} - k_{11}k_{32}k_{23}$. If a square

⁵This cipher is somewhat more difficult to understand than the others in this chapter, but it illustrates an important point about cryptanalysis that will be useful later on. This subsection can be skipped on a first reading.

matrix \mathbf{A} has a nonzero determinant, then the inverse of the matrix is computed as $[\mathbf{A}^{-1}]_{ij} = (\det \mathbf{A})^{-1}(-1)^{i+j}(\mathbf{D}_{ji})$, where (\mathbf{D}_{ji}) is the subdeterminant formed by deleting the j th row and the i th column of \mathbf{A} , $\det(\mathbf{A})$ is the determinant of \mathbf{A} , and $(\det \mathbf{A})^{-1}$ is the multiplicative inverse of $(\det \mathbf{A}) \bmod 26$.

Continuing our example,

$$\det \begin{pmatrix} 5 & 8 \\ 17 & 3 \end{pmatrix} = (5 \times 3) - (8 \times 17) = -121 \bmod 26 = 9$$

We can show that $9^{-1} \bmod 26 = 3$, because $9 \times 3 = 27 \bmod 26 = 1$ (see Chapter 2 or Appendix A). Therefore, we compute the inverse of \mathbf{A} as

$$\mathbf{A} = \begin{pmatrix} 5 & 8 \\ 17 & 3 \end{pmatrix}$$

$$\mathbf{A}^{-1} \bmod 26 = 3 \begin{pmatrix} 3 & -8 \\ -17 & 5 \end{pmatrix} = 3 \begin{pmatrix} 3 & 18 \\ 9 & 5 \end{pmatrix} = \begin{pmatrix} 9 & 54 \\ 27 & 15 \end{pmatrix} = \begin{pmatrix} 9 & 2 \\ 1 & 15 \end{pmatrix}$$

THE HILL ALGORITHM This encryption algorithm takes m successive plaintext letters and substitutes for them m ciphertext letters. The substitution is determined by m linear equations in which each character is assigned a numerical value ($a = 0, b = 1, \dots, z = 25$). For $m = 3$, the system can be described as

$$c_1 = (k_{11}p_1 + k_{21}p_2 + k_{31}p_3) \bmod 26$$

$$c_2 = (k_{12}p_1 + k_{22}p_2 + k_{32}p_3) \bmod 26$$

$$c_3 = (k_{13}p_1 + k_{23}p_2 + k_{33}p_3) \bmod 26$$

This can be expressed in terms of row vectors and matrices:⁶

$$(c_1 \ c_2 \ c_3) = (p_1 \ p_2 \ p_3) \begin{pmatrix} k_{11} & k_{12} & k_{13} \\ k_{21} & k_{22} & k_{23} \\ k_{31} & k_{32} & k_{33} \end{pmatrix} \bmod 26$$

or

$$\mathbf{C} = \mathbf{PK} \bmod 26$$

where \mathbf{C} and \mathbf{P} are row vectors of length 3 representing the plaintext and ciphertext, and \mathbf{K} is a 3×3 matrix representing the encryption key. Operations are performed mod 26.

⁶Some cryptography books express the plaintext and ciphertext as column vectors, so that the column vector is placed after the matrix rather than the row vector placed before the matrix. Sage uses row vectors, so we adopt that convention.

For example, consider the plaintext “paymoremoney” and use the encryption key

$$\mathbf{K} = \begin{pmatrix} 17 & 17 & 5 \\ 21 & 18 & 21 \\ 2 & 2 & 19 \end{pmatrix}$$

The first three letters of the plaintext are represented by the vector (15 0 24). Then $(15\ 0\ 24)\mathbf{K} = (303\ 303\ 531) \bmod 26 = (17\ 17\ 11) = \text{RRL}$. Continuing in this fashion, the ciphertext for the entire plaintext is RRLMWBKASPDH.

Decryption requires using the inverse of the matrix \mathbf{K} . We can compute $\det \mathbf{K} = 23$, and therefore, $(\det \mathbf{K})^{-1} \bmod 26 = 17$. We can then compute the inverse as⁷

$$\mathbf{K}^{-1} = \begin{pmatrix} 4 & 9 & 15 \\ 15 & 17 & 6 \\ 24 & 0 & 17 \end{pmatrix}$$

This is demonstrated as

$$\begin{pmatrix} 17 & 17 & 5 \\ 21 & 18 & 21 \\ 2 & 2 & 19 \end{pmatrix} \begin{pmatrix} 4 & 9 & 15 \\ 15 & 17 & 6 \\ 24 & 0 & 17 \end{pmatrix} = \begin{pmatrix} 443 & 442 & 442 \\ 858 & 495 & 780 \\ 494 & 52 & 365 \end{pmatrix} \bmod 26 = \begin{pmatrix} 1 & 0 & 0 \\ 0 & 1 & 0 \\ 0 & 0 & 1 \end{pmatrix}$$

It is easily seen that if the matrix \mathbf{K}^{-1} is applied to the ciphertext, then the plaintext is recovered.

In general terms, the Hill system can be expressed as

$$\mathbf{C} = \mathbf{E}(\mathbf{K}, \mathbf{P}) = \mathbf{PK} \bmod 26$$

$$\mathbf{P} = \mathbf{D}(\mathbf{K}, \mathbf{C}) = \mathbf{CK}^{-1} \bmod 26 = \mathbf{PKK}^{-1} = \mathbf{P}$$

As with Playfair, the strength of the Hill cipher is that it completely hides single-letter frequencies. Indeed, with Hill, the use of a larger matrix hides more frequency information. Thus, a 3×3 Hill cipher hides not only single-letter but also two-letter frequency information.

Although the Hill cipher is strong against a ciphertext-only attack, it is easily broken with a known plaintext attack. For an $m \times m$ Hill cipher, suppose we have m plaintext–ciphertext pairs, each of length m . We label the pairs $\mathbf{P}_j = (p_{1j}p_{1j} \dots p_{mj})$ and $\mathbf{C}_j = (c_{1j}c_{1j} \dots c_{mj})$ such that $\mathbf{C}_j = \mathbf{P}_j\mathbf{K}$ for $1 \leq j \leq m$ and for some unknown key matrix \mathbf{K} . Now define two $m \times m$ matrices $\mathbf{X} = (p_{ij})$ and $\mathbf{Y} = (c_{ij})$. Then we can form the matrix equation $\mathbf{Y} = \mathbf{XK}$. If \mathbf{X} has an inverse, then we can determine $\mathbf{K} = \mathbf{X}^{-1}\mathbf{Y}$. If \mathbf{X} is not invertible, then a new version of \mathbf{X} can be formed with additional plaintext–ciphertext pairs until an invertible \mathbf{X} is obtained.

Consider this example. Suppose that the plaintext “hillcipher” is encrypted using a 2×2 Hill cipher to yield the ciphertext HCRZSSXNSP. Thus, we know that $(7\ 8)\mathbf{K} \bmod 26 = (7\ 2)$; $(11\ 11)\mathbf{K} \bmod 26 = (17\ 25)$; and so on. Using the first two plaintext–ciphertext pairs, we have

⁷The calculations for this example are provided in detail in Appendix A.

$$\begin{pmatrix} 7 & 2 \\ 17 & 25 \end{pmatrix} = \begin{pmatrix} 7 & 8 \\ 11 & 11 \end{pmatrix} \mathbf{K} \pmod{26}$$

The inverse of \mathbf{X} can be computed:

$$\begin{pmatrix} 7 & 8 \\ 11 & 11 \end{pmatrix}^{-1} = \begin{pmatrix} 25 & 22 \\ 1 & 23 \end{pmatrix}$$

so

$$\mathbf{K} = \begin{pmatrix} 25 & 22 \\ 1 & 23 \end{pmatrix} \begin{pmatrix} 7 & 2 \\ 17 & 25 \end{pmatrix} = \begin{pmatrix} 549 & 600 \\ 398 & 577 \end{pmatrix} \pmod{26} = \begin{pmatrix} 3 & 2 \\ 8 & 5 \end{pmatrix}$$

This result is verified by testing the remaining plaintext–ciphertext pairs.

Polyalphabetic Ciphers

Another way to improve on the simple monoalphabetic technique is to use different monoalphabetic substitutions as one proceeds through the plaintext message. The general name for this approach is **polyalphabetic substitution cipher**. All these techniques have the following features in common:

1. A set of related monoalphabetic substitution rules is used.
2. A key determines which particular rule is chosen for a given transformation.

VIGENÈRE CIPHER The best known, and one of the simplest, polyalphabetic ciphers is the Vigenère cipher. In this scheme, the set of related monoalphabetic substitution rules consists of the 26 Caesar ciphers with shifts of 0 through 25. Each cipher is denoted by a key letter, which is the ciphertext letter that substitutes for the plaintext letter a. Thus, a Caesar cipher with a shift of 3 is denoted by the key value 3.⁸

We can express the Vigenère cipher in the following manner. Assume a sequence of plaintext letters $P = p_0, p_1, p_2, \dots, p_{n-1}$ and a key consisting of the sequence of letters $K = k_0, k_1, k_2, \dots, k_{m-1}$, where typically $m < n$. The sequence of ciphertext letters $C = C_0, C_1, C_2, \dots, C_{n-1}$ is calculated as follows:

$$\begin{aligned} C &= C_0, C_1, C_2, \dots, C_{n-1} = E(K, P) = E[(k_0, k_1, k_2, \dots, k_{m-1}), (p_0, p_1, p_2, \dots, p_{n-1})] \\ &= (p_0 + k_0) \pmod{26}, (p_1 + k_1) \pmod{26}, \dots, (p_{m-1} + k_{m-1}) \pmod{26}, \\ &\quad (p_m + k_0) \pmod{26}, (p_{m+1} + k_1) \pmod{26}, \dots, (p_{2m-1} + k_{m-1}) \pmod{26}, \dots \end{aligned}$$

Thus, the first letter of the key is added to the first letter of the plaintext, mod 26, the second letters are added, and so on through the first m letters of the plaintext. For the next m letters of the plaintext, the key letters are repeated. This process

⁸To aid in understanding this scheme and also to aid in its use, a matrix known as the Vigenère tableau is often used. This tableau is discussed in a document at box.com/Crypto8e.

continues until all of the plaintext sequence is encrypted. A general equation of the encryption process is

$$C_i = (p_i + k_{i \bmod m}) \bmod 26 \quad (3.3)$$

Compare this with Equation (3.1) for the Caesar cipher. In essence, each plaintext character is encrypted with a different Caesar cipher, depending on the corresponding key character. Similarly, decryption is a generalization of Equation (3.2):

$$p_i = (C_i - k_{i \bmod m}) \bmod 26 \quad (3.4)$$

To encrypt a message, a key is needed that is as long as the message. Usually, the key is a repeating keyword. For example, if the keyword is *deceptive*, the message “we are discovered save yourself” is encrypted as

```
key:           deceptivedeceptive
plaintext:    wearediscoveredsaveyourself
ciphertext:   ZICVTWQNGRZGVTWAVZHCQYGLMGJ
```

Expressed numerically, we have the following result.

key	3	4	2	4	15	19	8	21	4	3	4	2	4	15
plaintext	22	4	0	17	4	3	8	18	2	14	21	4	17	4
ciphertext	25	8	2	21	19	22	16	13	6	17	25	6	21	19

key	19	8	21	4	3	4	2	4	15	19	8	21	4
plaintext	3	18	0	21	4	24	14	20	17	18	4	11	5
ciphertext	22	0	21	25	7	2	16	24	6	11	12	6	9

The strength of this cipher is that there are multiple ciphertext letters for each plaintext letter, one for each unique letter of the keyword. Thus, the letter frequency information is obscured. However, not all knowledge of the plaintext structure is lost. For example, Figure 3.6 shows the frequency distribution for a Vigenère cipher with a keyword of length 9. An improvement is achieved over the Playfair cipher, but considerable frequency information remains.

It is instructive to sketch a method of breaking this cipher, because the method reveals some of the mathematical principles that apply in cryptanalysis.

First, suppose that the opponent believes that the ciphertext was encrypted using either monoalphabetic substitution or a Vigenère cipher. A simple test can be made to make a determination. If a monoalphabetic substitution is used, then the statistical properties of the ciphertext should be the same as that of the language of the plaintext. Thus, referring to Figure 3.5, there should be one cipher letter with a relative frequency of occurrence of about 12.7%, one with about 9.06%, and so on. If only a single message is available for analysis, we would not expect an exact match of this small sample with the statistical profile of the plaintext language. Nevertheless, if the correspondence is close, we can assume a monoalphabetic substitution.

If, on the other hand, a Vigenère cipher is suspected, then progress depends on determining the length of the keyword, as will be seen in a moment. For now, let us concentrate on how the keyword length can be determined. The important insight that leads to a solution is the following: If two identical sequences of plaintext letters occur at a distance that is an integer multiple of the keyword length, they will generate identical ciphertext sequences. In the foregoing example, two instances of the sequence “red” are separated by nine character positions. Consequently, in both cases, r is encrypted using key letter *e*, e is encrypted using key letter *p*, and d is encrypted using key letter *t*. Thus, in both cases, the ciphertext sequence is VTW. We indicate this above by underlining the relevant ciphertext letters and shading the relevant ciphertext numbers.

An analyst looking at only the ciphertext would detect the repeated sequences VTW at a displacement of 9 and make the assumption that the keyword is either three or nine letters in length. The appearance of VTW twice could be by chance and may not reflect identical plaintext letters encrypted with identical key letters. However, if the message is long enough, there will be a number of such repeated ciphertext sequences. By looking for common factors in the displacements of the various sequences, the analyst should be able to make a good guess of the keyword length.

Solution of the cipher now depends on an important insight. If the keyword length is *m*, then the cipher, in effect, consists of *m* monoalphabetic substitution ciphers. For example, with the keyword DECEPTIVE, the letters in positions 1, 10, 19, and so on are all encrypted with the same monoalphabetic cipher. Thus, we can use the known frequency characteristics of the plaintext language to attack each of the monoalphabetic ciphers separately.

The periodic nature of the keyword can be eliminated by using a nonrepeating keyword that is as long as the message itself. Vigenère proposed what is referred to as an **autokey system**, in which a keyword is concatenated with the plaintext itself to provide a running key. For our example,

key:	<i>deceptivewearediscoveredsav</i>
plaintext:	<i>wearediscoveredsaveyourself</i>
ciphertext:	ZICVTWQNGKZEIIGASXSTSLVVWLA

Even this scheme is vulnerable to cryptanalysis. Because the key and the plaintext share the same frequency distribution of letters, a statistical technique can be applied. For example, *e* enciphered by *e*, by Figure 3.5, can be expected to occur with a frequency of $(0.127)^2 \approx 0.016$, whereas *t* enciphered by *t* would occur only about half as often. These regularities can be exploited to achieve successful cryptanalysis.⁹

VERNAM CIPHER The ultimate defense against such a cryptanalysis is to choose a keyword that is as long as the plaintext and has no statistical relationship to it. Such a system was introduced by an AT&T engineer named Gilbert Vernam in 1918.

⁹Although the techniques for breaking a Vigenère cipher are by no means complex, a 1917 issue of *Scientific American* characterized this system as “impossible of translation.” This is a point worth remembering when similar claims are made for modern algorithms.

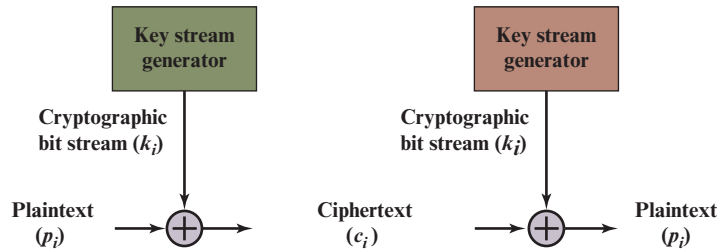

Figure 3.7 Vernam Cipher

His system works on binary data (bits) rather than letters. The system can be expressed succinctly as follows (Figure 3.7):

$$c_i = p_i \oplus k_i$$

where

- p_i = i th binary digit of plaintext
- k_i = i th binary digit of key
- c_i = i th binary digit of ciphertext
- \oplus = exclusive-or (XOR) operation

Compare this with Equation (3.3) for the Vigenère cipher.

Thus, the ciphertext is generated by performing the bitwise XOR of the plaintext and the key. Because of the properties of the XOR, decryption simply involves the same bitwise operation:

$$p_i = c_i \oplus k_i$$

which compares with Equation (3.4).

The essence of this technique is the means of construction of the key. Vernam proposed the use of a running loop of tape that eventually repeated the key, so that in fact the system worked with a very long but repeating keyword. Although such a scheme, with a long key, presents formidable cryptanalytic difficulties, it can be broken with sufficient ciphertext, the use of known or probable plaintext sequences, or both.

One-Time Pad

An Army Signal Corp officer, Joseph Mauborgne, proposed an improvement to the Vernam cipher that yields the ultimate in security. Mauborgne suggested using a random key that is as long as the message, so that the key need not be repeated. In addition, the key is to be used to encrypt and decrypt a single message, and then is discarded. Each new message requires a new key of the same length as the new message. Such a scheme, known as a **one-time pad**, is unbreakable. It produces random output that bears no statistical relationship to the plaintext. Because the ciphertext

contains no information whatsoever about the plaintext, there is simply no way to break the code.

An example should illustrate our point. Suppose that we are using a Vigenère scheme with 27 characters in which the twenty-seventh character is the space character, but with a one-time key that is as long as the message. Consider the ciphertext

ANKYODKYUREPFJBYOJDSPLREYIUNOFDOIUERFPLUYTS

We now show two different decryptions using two different keys:

ciphertext: ANKYODKYUREPFJBYOJDSPLREYIUNOFDOIUERFPLUYTS
 key: *pxlmvmsydofoyrvzwc tnlebnecvgdupahfzzlmnyih*
 plaintext: mr mustard with the candlestick in the hall

ciphertext: ANKYODKYUREPFJBYOJDSPLREYIUNOFDOIUERFPLUYTS
 key: *pftgpmiydgaxgoufhklllmhsqdqogtewbqfgyvuhwt*
 plaintext: miss scarlet with the knife in the library

Suppose that a cryptanalyst had managed to find these two keys. Two plausible plaintexts are produced. How is the cryptanalyst to decide which is the correct decryption (i.e., which is the correct key)? If the actual key were produced in a truly random fashion, then the cryptanalyst cannot say that one of these two keys is more likely than the other. Thus, there is no way to decide which key is correct and therefore which plaintext is correct.

In fact, given any plaintext of equal length to the ciphertext, there is a key that produces that plaintext. Therefore, if you did an exhaustive search of all possible keys, you would end up with many legible plaintexts, with no way of knowing which was the intended plaintext. Therefore, the code is unbreakable.

The security of the one-time pad is entirely due to the randomness of the key. If the stream of characters that constitute the key is truly random, then the stream of characters that constitute the ciphertext will be truly random. Thus, there are no patterns or regularities that a cryptanalyst can use to attack the ciphertext.

In theory, we need look no further for a cipher. The one-time pad offers complete security but, in practice, has two fundamental difficulties:

1. There is the practical problem of making large quantities of random keys. Any heavily used system might require millions of random characters on a regular basis. Supplying truly random characters in this volume is a significant task.
2. Even more daunting is the problem of key distribution and protection. For every message to be sent, a key of equal length is needed by both sender and receiver. Thus, a mammoth key distribution problem exists.

Because of these difficulties, the one-time pad is of limited utility and is useful primarily for low-bandwidth channels requiring very high security.

The one-time pad is the only cryptosystem that exhibits what is referred to as *perfect secrecy*. This concept is explored in Appendix B.

3.3 TRANSPOSITION TECHNIQUES

All the techniques examined so far involve the substitution of a ciphertext symbol for a plaintext symbol. A very different kind of mapping is achieved by performing some sort of permutation on the plaintext letters. This technique is referred to as a transposition cipher.

The simplest such cipher is the rail fence technique, in which the plaintext is written down as a sequence of diagonals and then read off as a sequence of rows. For example, to encipher the message “meet me after the toga party” with a rail fence of depth 2, we write the following:

```
m e m a t r h t g p r y
e t e f e t e o a a t
```

The encrypted message is

```
MEMATRHTGPRYETEFETEOAAT
```

This sort of thing would be trivial to cryptanalyze. A more complex scheme is to write the message in a rectangle, row by row, and read the message off, column by column, but permute the order of the columns. The order of the columns then becomes the key to the algorithm. For example,

```
Key:           4 3 1 2 5 6 7
Plaintext:    a t t a c k p
              o s t p o n e
              d u n t i l t
              w o a m x y z
Ciphertext:   TTNAAPTMTSUOAODWCOIXKNLYPETZ
```

Thus, in this example, the key is 4312567. To encrypt, start with the column that is labeled 1, in this case column 3. Write down all the letters in that column. Proceed to column 4, which is labeled 2, then column 2, then column 1, then columns 5, 6, and 7.

A pure transposition cipher is easily recognized because it has the same letter frequencies as the original plaintext. For the type of columnar transposition just shown, cryptanalysis is fairly straightforward and involves laying out the ciphertext in a matrix and playing around with column positions. Digram and trigram frequency tables can be useful.

The transposition cipher can be made significantly more secure by performing more than one stage of transposition. The result is a more complex permutation that is not easily reconstructed. Thus, if the foregoing message is reencrypted using the same algorithm,

```

Key:      4 3 1 2 5 6 7
Input:    t t n a a p t
          m t s u o a o
          d w c o i x k
          n l y p e t z
Output:   NSCYAUOPTTWLTMDNAOIEPAXTTOKZ
    
```

To visualize the result of this double transposition, designate the letters in the original plaintext message by the numbers designating their position. Thus, with 28 letters in the message, the original sequence of letters is

```

01 02 03 04 05 06 07 08 09 10 11 12 13 14
15 16 17 18 19 20 21 22 23 24 25 26 27 28
    
```

After the first transposition, we have

```

03 10 17 24 04 11 18 25 02 09 16 23 01 08
15 22 05 12 19 26 06 13 20 27 07 14 21 28
    
```

which has a somewhat regular structure. But after the second transposition, we have

```

17 09 05 27 24 16 12 07 10 02 22 20 03 25
15 13 04 23 19 14 11 01 26 21 18 08 06 28
    
```

This is a much less structured permutation and is much more difficult to cryptanalyze.

3.4 KEY TERMS, REVIEW QUESTIONS, AND PROBLEMS

Key Terms

block cipher brute-force attack cipher ciphertext computationally secure conventional encryption cryptanalysis cryptographic system cryptography	cryptology deciphering decryption digram enciphering encryption monoalphabetic substitution cipher one-time pad	permutation plaintext polyalphabetic substitution cipher single-key encryption stream cipher symmetric encryption unconditionally secure
--	---	---

Review Questions

- 3.1 Describe the main requirements for the secure use of symmetric encryption.
- 3.2 What are the two basic functions used in encryption algorithms?

- 3.3 Differentiate between secret-key encryption and public-key encryption.
- 3.4 What is the difference between a block cipher and a stream cipher?
- 3.5 What are the two general approaches to attacking a cipher?
- 3.6 List and briefly define types of cryptanalytic attacks based on what is known to the attacker.
- 3.7 Briefly describe the criteria that define a computationally secure cipher.
- 3.8 Why is the Caesar cipher substitution technique vulnerable to a brute-force cryptanalysis?
- 3.9 How much key space is available when a monoalphabetic substitution cipher is used to replace plaintext with ciphertext?
- 3.10 What is the drawback of a Playfair cipher?
- 3.11 What is the difference between a monoalphabetic cipher and a polyalphabetic cipher?
- 3.12 How can an attacker determine the length of the keyword used in the Vigenère cipher?
- 3.13 What is a transposition cipher?
- 3.14 What are the drawbacks of Steganography?

Problems

- 3.1 A generalization of the Caesar cipher, known as the affine Caesar cipher, has the following form: For each plaintext letter p , substitute the ciphertext letter C :

$$C = E([a, b], p) = (ap + b) \bmod 26$$

A basic requirement of any encryption algorithm is that it be one-to-one. That is, if $p \neq q$, then $E(k, p) \neq E(k, q)$. Otherwise, decryption is impossible, because more than one plaintext character maps into the same ciphertext character. The affine Caesar cipher is not one-to-one for all values of a . For example, for $a = 2$ and $b = 3$, then $E([a, b], 0) = E([a, b], 13) = 3$.

- a. Are there any limitations on the value of b ? Explain why or why not.
 - b. Determine which values of a are not allowed.
 - c. Provide a general statement of which values of a are and are not allowed. Justify your statement.
- 3.2 What is the number of monoalphabetic permutation ciphers over n elements?
- 3.3 A ciphertext has been generated with an affine cipher. The most frequent letter of the ciphertext is “C,” and the second most frequent letter of the ciphertext is “Z.” Break this code.
- 3.4 The following ciphertext was generated using a simple substitution algorithm.

```

hzsrnqc klyy wqc flo mflwf ol zqdn nsoznj wskn lj xzsrbjnf,
wzsxz gqv zqhhnf ol ozn glco zlfnc hnlhrn; nsoznj
jnrqosdnc lj fnqj kjsnfb, wwsxz sc xnjoqsfrv gljn efeceqr.
zn rsdnb qrlfn sf zsc zlecn sf cqdsrrn jlw, wwsznj flfn
hnfnojgonb. q csfyrn blgncosx cekksxnb ol cnjdn zsg. zn
pjqmqqconb qfb bsfnb qo ozn xrep, qo zlejc gqozngqosxqrrv
ksanb, sf ozn cqgn jllg, qo ozn cqgn oqprn, fndnj oqmsfy
zsc gnqrc wsoz loznj gngpnjc, gexz rncc pjsfysfy q yenco
wsoz zsg; qfb wnfo zlgn qo naqxov gsbfsyzo, lfrv ol jnosjn
qo lfxn ol pnb. zn fndnj ecnb ozn xlcx xzqgnjc wwsxz ozn
jnkllg hjldsbnc klj soc kqdlejnb gngpnjc. zn hqccnb onf
zlejc leo lk ozn ownfov-klej sf cqdsrrn jlw, nsoznj sf
crnhsfy lj gqmsfy zsc olsrno.

```

Decrypt this message.

Hints:

1. As you know, the most frequently occurring letter in English is e. Therefore, the first or second (or perhaps third?) most common character in the message is likely to stand for e. Also, e is often seen in pairs (e.g., meet, fleet, speed, seen, been, agree, etc.). Try to find a character in the ciphertext that decodes to e.
2. The most common word in English is “the.” Use this fact to guess the characters that stand for t and h.
3. Decipher the rest of the message by deducing additional words.

Warning: The resulting message is in English but may not make much sense on a first reading.

- 3.5 One way to solve the key distribution problem is to use a book that both the sender and the receiver possess. The sender and the receiver use the location of a word in the book as the code. In order to avoid problems when a particular plaintext word is not present in the book, the method can be modified to encode individual letters by the location of a word beginning with that letter. Further, to ease the encoding and decoding process, the encoding of a letter is the pair of line number and the location of the word in that line.

For example, the first sentence of the 1931 book *The American Black Chamber* (by Herbert Yardley) is:

The secret activities of the American Black Chamber, which I directed, ceased in 1929, sixteen years after I arrived at the Department of State as a young telegraph operator.

Using this book, the message “tact” can be encoded as (3,4),(1,3),(1,8),(3,4).

The particular scheme discussed in this problem is based on this sentence. Answer the questions given the following enciphered message:

(1,6), (1,8) (2,1) (3,5), (1,2), (3,4)

- a. What is the plaintext?
 - b. How secure is the method?
 - c. What kind of practical problems may arise while using this method?
- 3.6 In one of his cases, Sherlock Holmes was confronted with the following message.

534 C2 13 127 36 31 4 17 21 41
DOUGLAS 109 293 5 37 BIRLSTONE
26 BIRLSTONE 9 127 171

Although Watson was puzzled, Holmes was able immediately to deduce the type of cipher. Can you?

- 3.7
- a. Given the encryption of a long plaintext, how can one possibly determine if the encryption is by the Playfair cipher?
 - b. The Playfair cipher has the property that if the decryption of a ciphertext digraph AB is PQ, then the decryption of the reverse digraph BA will be QP. How can one use this property to cryptanalyze a ciphertext encrypted using the Playfair cipher?
 - c. Unlike the Playfair cipher which uses a single 5×5 matrix, the two-square cipher uses two 5×5 matrices placed one below the other. The two matrices are constructed similar to the Playfair cipher with two different keywords. The encryption proceeds digraph-wise, in which a rectangle is formed by the first character’s position in the first matrix and the second character’s position in the second matrix. Then the two characters at the remaining two vertices of the rectangle become the ciphertext. In case the characters of the digraph fall in the same column, the digraph encrypts to itself.

Given the two keywords TARGET and HELP, encrypt the plaintext “we will rock” using the two-square cipher.

- 3.8** A disadvantage of the general monoalphabetic cipher is that both sender and receiver must commit the permuted cipher sequence to memory. A common technique for avoiding this is to use a keyword from which the cipher sequence can be generated. For example, using the keyword CRYPTO, write out the keyword followed by unused letters in normal order, and match this against the plaintext letters:

```
plain:  a b c d e f g h i j k l m n o p q r s t u v w x y z
cipher: C R Y P T O A B D E F G H I J K L M N Q S U V W X Z
```

If it is felt that this process does not produce sufficient mixing, write the remaining letters on successive lines and then generate the sequence by reading down the columns:

```
  C R Y P T O
  A B D E F G
  H I J K L M
  N Q S U V W
  X Z
```

This yields the sequence:

C A H N X R B I Q Z Y D J S P E K U T F L V O G M W

Such a system is used in the example in Section 3.2 (the one that begins “it was disclosed yesterday”). Determine the keyword.

- 3.9** When the PT-109 American patrol boat, under the command of Lieutenant John F. Kennedy, was sunk by a Japanese destroyer, a message was received at an Australian wireless station in Playfair code:

```
KXJEY UREBE ZWEHE WRYTU HEYFS
KREHE GOYFI WTTTU OLKSY CAJPO
BOTEI ZONTX BYBNT GONEY CUZWR
GDSON SXBOU YWRHE BAAHY USEDQ
```

The key used was *royal new zealand navy*. Decrypt the message. Translate TT into tt.

- 3.10** **a.** Construct a Playfair matrix with the key *algorithm*.
b. Construct a Playfair matrix with the key *cryptography*. Make a reasonable assumption about how to treat redundant letters in the key.
- 3.11** **a.** Using this Playfair matrix:

J/K	C	D	E	F
U	N	P	Q	S
Z	V	W	X	Y
R	A	L	G	O
B	I	T	H	M

Encrypt this message:

I only regret that I have but one life to give for my country.

Note: This message is by Nathan Hale, a soldier in the American Revolutionary War.

- b.** Repeat part (a) using the Playfair matrix from Problem 3.10a.

- c. How do you account for the results of this problem? Can you generalize your conclusion?
- 3.12 a. Given the keyword SECURITY, encrypt the following plaintext using the autokey system.

We are discovered. Save yourself.

- b. Given a long ciphertext which has been encrypted with the autokey system, how can one find the secret key used?
- 3.13 What substitution system results when we use a 1×25 Playfair matrix?
- 3.14 a. Encrypt the message “meet me at the usual place at ten rather than eight o clock”

using the Hill cipher with the key $\begin{pmatrix} 7 & 3 \\ 2 & 5 \end{pmatrix}$. Show your calculations and the result.

- b. Show the calculations for the corresponding decryption of the ciphertext to recover the original plaintext.
- 3.15 We have shown that the Hill cipher succumbs to a known plaintext attack if sufficient plaintext–ciphertext pairs are provided. It is even easier to solve the Hill cipher if a chosen plaintext attack can be mounted. Describe such an attack.

- 3.16 In a language having p letters, where p is a prime number, we can encode the letters by the set of integers $Z_p = \{0, 1, 2, \dots, p - 1\}$. Suppose we use the Hill cipher

with the matrix $\begin{pmatrix} a & b \\ c & d \end{pmatrix}$ modulo p to encrypt messages in this language. It can be

shown that this requires the matrix to be invertible modulo p . A matrix is invertible modulo p if none of its rows can be represented as a linear combination of the other rows modulo p . If the i^{th} row is denoted by R_i , then this condition translates to $R_i \neq (c_1R_1 + c_2R_2 + \dots + c_{i-1}R_{i-1})$ modulo p , where $c_i \in Z_p$ for all i . Determine the number of different (good) keys there are for a 2×2 Hill cipher without counting them one by one, using the following steps:

- a. Assume that no row can be all zeros, because then this row can be represented as a linear combination of other rows with the coefficient c_i being 0. Find the number of possibilities for the first row.
- b. The second row should not be a multiple of the first row modulo p . Find the number of possibilities for the second row.
- c. Find the total number of 2×2 matrices, which can be used in the Hill cipher.
- d. If we encrypt 3 letters at a time using the Hill cipher, the matrix will have to be of the order 3×3 . Using arguments similar to the above, find the number of good matrices for this size.
- e. If the matrix is of size $n \times n$, where n is a product of two prime numbers p and q , then the fraction of all matrices that are invertible modulo n is equal to the fraction of all matrices that are invertible modulo p times the fraction of all matrices that are invertible modulo q . Using this knowledge, find the number of 2×2 invertible matrices modulo 26.
- 3.17 Calculate the determinant mod 26 of

a. $\begin{pmatrix} 23 & 5 \\ 13 & 7 \end{pmatrix}$ b. $\begin{pmatrix} 21 & 13 & 25 \\ 5 & 7 & 18 \\ 3 & 14 & 12 \end{pmatrix}$

- 3.18 Determine the inverse mod 26 of

a. $\begin{pmatrix} 3 & 4 \\ 15 & 9 \end{pmatrix}$ b. $\begin{pmatrix} 5 & 3 & 15 \\ 21 & 2 & 6 \\ 1 & 12 & 25 \end{pmatrix}$

- 3.19 Using the Vigenère cipher, encrypt the word “cryptographic” using the word “eng”

- 3.20** This problem explores the use of a one-time pad version of the Vigenère cipher. In this scheme, the key is a stream of random numbers between 0 and 26. For example, if the key is 3 19 5 . . . , then the first letter of plaintext is encrypted with a shift of 3 letters, the second with a shift of 19 letters, the third with a shift of 5 letters, and so on.
- Encrypt the plaintext `sendmoremoney` with the key stream
- 3 11 5 7 17 21 0 11 14 8 7 13 9
- Using the ciphertext produced in part (a), find a key so that the ciphertext decrypts to the plaintext `cashnotneeded`.
- 3.21** In one of Dorothy Sayers's mysteries, Lord Peter is confronted with the message shown in Figure 3.8. He also discovers the key to the message, which is a sequence of integers:

I thought to see the fairies in the fields, but I saw only the evil elephants with their black backs. Woe! how that sight awed me! The elves danced all around and about while I heard voices calling clearly. Ah! how I tried to see—throw off the ugly cloud—but no blind eye of a mortal was permitted to spy them. So then came minstrels, having gold trumpets, harps and drums. These played very loudly beside me, breaking that spell. So the dream vanished, whereat I thanked Heaven. I shed many tears before the thin moon rose up, frail and faint as a sickle of straw. Now though the Enchanter gnash his teeth vainly, yet shall he return as the Spring returns. Oh, wretched man! Hell gapes, Erebus now lies open. The mouths of Death wait on thy end.

Figure 3.8 A Puzzle for Lord Peter

787656543432112343456567878878765654
3432112343456567878878765654433211234

- Decrypt the message. *Hint:* What is the largest integer value?
- If the algorithm is known but not the key, how secure is the scheme?
- If the key is known but not the algorithm, how secure is the scheme?

Programming Problems

- Write a program that can encrypt and decrypt using the general Caesar cipher, also known as an additive cipher.
- Write a program that can encrypt and decrypt using the affine cipher described in Problem 3.1.
- Write a program that can perform a letter frequency attack on an additive cipher without human intervention. Your software should produce possible plaintexts in rough order of likelihood. It would be good if your user interface allowed the user to specify “give me the top 10 possible plaintexts.”
- Write a program that can perform a letter frequency attack on any monoalphabetic substitution cipher without human intervention. Your software should produce possible plaintexts in rough order of likelihood. It would be good if your user interface allowed the user to specify “give me the top 10 possible plaintexts.”
- Create software that can encrypt and decrypt using a 2×2 Hill cipher.
- Create software that can perform a fast known plaintext attack on a Hill cipher, given the dimension m . How fast are your algorithms, as a function of m ?

CHAPTER 4

BLOCK CIPHERS AND THE DATA ENCRYPTION STANDARD

4.1 Traditional Block Cipher Structure

- Stream Ciphers and Block Ciphers
- Motivation for the Feistel Cipher Structure
- The Feistel Cipher

4.2 The Data Encryption Standard

- DES Encryption
- DES Decryption

4.3 A DES Example

- Results
- The Avalanche Effect

4.4 The Strength of DES

- The Use of 56-Bit Keys
- The Nature of the DES Algorithm
- Timing Attacks

4.5 Block Cipher Design Principles

- Number of Rounds
- Design of Function F
- Key Schedule Algorithm

4.6 Key Terms, Review Questions, and Problems

LEARNING OBJECTIVES

After studying this chapter, you should be able to

- ◆ Understand the distinction between stream ciphers and block ciphers.
- ◆ Present an overview of the Feistel cipher and explain how decryption is the inverse of encryption.
- ◆ Present an overview of Data Encryption Standard (DES).
- ◆ Explain the concept of the avalanche effect.
- ◆ Discuss the cryptographic strength of DES.
- ◆ Summarize the principal block cipher design principles.

The objective of this chapter is to illustrate the principles of modern symmetric ciphers. For this purpose, we focus on the most widely used symmetric cipher: the Data Encryption Standard (DES). Although numerous symmetric ciphers have been developed since the introduction of DES, and although it is destined to be replaced by the Advanced Encryption Standard (AES), DES remains the most important such algorithm. Furthermore, a detailed study of DES provides an understanding of the principles used in other symmetric ciphers.

This chapter begins with a discussion of the general principles of symmetric block ciphers, which are the principal type of symmetric ciphers studied in this book. The other form of symmetric ciphers, stream ciphers, are discussed in Chapter 8. Next, we cover full DES. Following this look at a specific algorithm, we return to a more general discussion of block cipher design.

4.1 TRADITIONAL BLOCK CIPHER STRUCTURE

Several important symmetric block encryption algorithms in current use are based on a structure referred to as a Feistel block cipher [FEIS73]. For that reason, it is important to examine the design principles of the Feistel cipher. We begin with a comparison of stream ciphers and block ciphers. Then we discuss the motivation for the Feistel block cipher structure. Finally, we discuss some of its implications.

Stream Ciphers and Block Ciphers

A **stream cipher** is one that encrypts a digital data stream one bit or one byte at a time. Examples of classical stream ciphers are the autokeyed Vigenère cipher and the Vernam cipher. In the ideal case, a one-time pad version of the Vernam cipher would be used (Figure 3.7), in which the keystream (k_i) is as long as the

plaintext bit stream (p_i). If the cryptographic keystream is random, then this cipher is unbreakable by any means other than acquiring the keystream. However, the keystream must be provided to both users in advance via some independent and secure channel. This introduces insurmountable logistical problems if the intended data traffic is very large.

Accordingly, for practical reasons, the bit-stream generator must be implemented as an algorithmic procedure, so that the cryptographic bit stream can be produced by both users. In this approach (Figure 4.1a), the bit-stream generator is a key-controlled algorithm and must produce a bit stream that is cryptographically strong. That is, it must be computationally impractical to predict future portions of the bit stream based on previous portions of the bit stream. The two users need only share the generating key, and each can produce the keystream.

A **block cipher** is one in which a block of plaintext is treated as a whole and used to produce a ciphertext block of equal length. Typically, a block size of 64 or 128 bits is used. As with a stream cipher, the two users share a symmetric encryption key (Figure 4.1b). Using some of the modes of operation explained in Chapter 7, a block cipher can be used to achieve the same effect as a stream cipher.

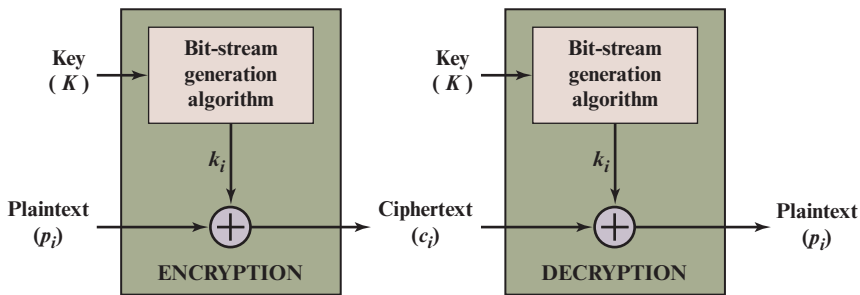

(a) Stream cipher using algorithmic bit-stream generator

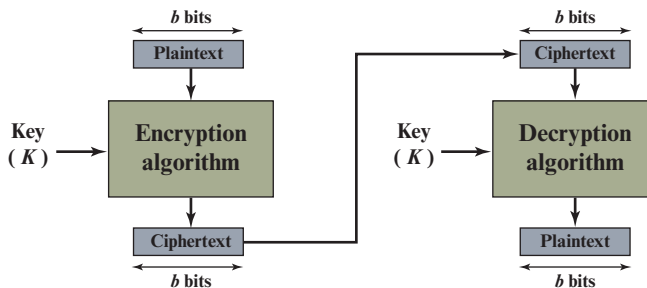

(b) Block cipher

Figure 4.1 Stream Cipher and Block Cipher

Far more effort has gone into analyzing block ciphers. In general, they seem applicable to a broader range of applications than stream ciphers. The vast majority of network-based symmetric cryptographic applications make use of block ciphers. Accordingly, the concern in this chapter, and in our discussions throughout the book of symmetric encryption, will primarily focus on block ciphers.

Motivation for the Feistel Cipher Structure

A block cipher operates on a plaintext block of n bits to produce a ciphertext block of n bits. There are 2^n possible different plaintext blocks and, for the encryption to be reversible (i.e., for decryption to be possible), each must produce a unique ciphertext block. Such a transformation is called reversible, or nonsingular. The following examples illustrate nonsingular and singular transformations for $n = 2$.

Reversible Mapping		Irreversible Mapping	
Plaintext	Ciphertext	Plaintext	Ciphertext
00	11	00	11
01	10	01	10
10	00	10	01
11	01	11	01

In the latter case, a ciphertext of 01 could have been produced by one of two plaintext blocks. So if we limit ourselves to reversible mappings, the number of different transformations is $2^n!$ ¹

Figure 4.2 illustrates the logic of a general substitution cipher for $n = 4$. A 4-bit input produces one of 16 possible input states, which is mapped by the substitution cipher into a unique one of 16 possible output states, each of which is represented by 4 ciphertext bits. The encryption and decryption mappings can be defined by a tabulation, as shown in Table 4.1. This is the most general form of block cipher and can be used to define any reversible mapping between plaintext and ciphertext. Feistel refers to this as the *ideal block cipher*, because it allows for the maximum number of possible encryption mappings from the plaintext block [FEIS75].

But there is a practical problem with the ideal block cipher. If a small block size, such as $n = 4$, is used, then the system is equivalent to a classical substitution cipher. Such systems, as we have seen, are vulnerable to a statistical analysis of the plaintext. This weakness is not inherent in the use of a substitution cipher but rather results from the use of a small block size. If n is sufficiently large and an arbitrary reversible substitution between plaintext and ciphertext is allowed, then the statistical characteristics of the source plaintext are masked to such an extent that this type of cryptanalysis is infeasible.

¹The reasoning is as follows: For the first plaintext, we can choose any of 2^n ciphertext blocks. For the second plaintext, we choose from among $2^n - 1$ remaining ciphertext blocks, and so on.

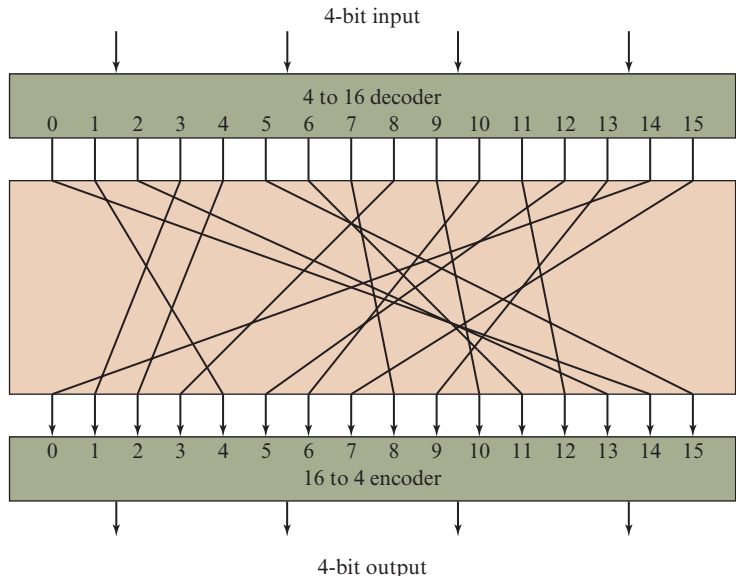

Figure 4.2 General n -bit- n -bit Block Substitution (shown with $n = 4$)

An arbitrary reversible substitution cipher (the ideal block cipher) for a large block size is not practical, however, from an implementation and performance point of view. For such a transformation, the mapping itself constitutes the key. Consider again Table 4.1, which defines one particular reversible mapping from

Table 4.1 Encryption and Decryption Tables for Substitution Cipher of Figure 4.2

Plaintext	Ciphertext	Ciphertext	Plaintext
0000	1110	0000	1110
0001	0100	0001	0011
0010	1101	0010	0100
0011	0001	0011	1000
0100	0010	0100	0001
0101	1111	0101	1100
0110	1011	0110	1010
0111	1000	0111	1111
1000	0011	1000	0111
1001	1010	1001	1101
1010	0110	1010	1001
1011	1100	1011	0110
1100	0101	1100	1011
1101	1001	1101	0010
1110	0000	1110	0000
1111	0111	1111	0101

plaintext to ciphertext for $n = 4$. The mapping can be defined by the entries in the second column, which show the value of the ciphertext for each plaintext block. This, in essence, is the key that determines the specific mapping from among all possible mappings. In this case, using this straightforward method of defining the key, the required key length is $(4 \text{ bits}) \times (16 \text{ rows}) = 64 \text{ bits}$. In general, for an n -bit ideal block cipher, the length of the key defined in this fashion is $n \times 2^n$ bits. For a 64-bit block, which is a desirable length to thwart statistical attacks, the required key length is $64 \times 2^{64} = 2^{70} \approx 10^{21}$ bits.

In considering these difficulties, Feistel points out that what is needed is an approximation to the ideal block cipher system for large n , built up out of components that are easily realizable [FEIS75]. But before turning to Feistel's approach, let us make one other observation. We could use the general block substitution cipher but, to make its implementation tractable, confine ourselves to a subset of the $2^n!$ possible reversible mappings. For example, suppose we define the mapping in terms of a set of linear equations. In the case of $n = 4$, we have

$$\begin{aligned}y_1 &= k_{11}x_1 + k_{12}x_2 + k_{13}x_3 + k_{14}x_4 \\y_2 &= k_{21}x_1 + k_{22}x_2 + k_{23}x_3 + k_{24}x_4 \\y_3 &= k_{31}x_1 + k_{32}x_2 + k_{33}x_3 + k_{34}x_4 \\y_4 &= k_{41}x_1 + k_{42}x_2 + k_{43}x_3 + k_{44}x_4\end{aligned}$$

where the x_i are the four binary digits of the plaintext block, the y_i are the four binary digits of the ciphertext block, the k_{ij} are the binary coefficients, and arithmetic is mod 2. The key size is just n^2 , in this case 16 bits. The danger with this kind of formulation is that it may be vulnerable to cryptanalysis by an attacker that is aware of the structure of the algorithm. In this example, what we have is essentially the Hill cipher discussed in Chapter 3, applied to binary data rather than characters. As we saw in Chapter 3, a simple linear system such as this is quite vulnerable.

The Feistel Cipher

Feistel proposed [FEIS73] that we can approximate the ideal block cipher by utilizing the concept of a **product cipher**, which is the execution of two or more simple ciphers in sequence in such a way that the final result or product is cryptographically stronger than any of the component ciphers. The essence of the approach is to develop a block cipher with a key length of k bits and a block length of n bits, allowing a total of 2^k possible transformations, rather than the $2^n!$ transformations available with the ideal block cipher.

In particular, Feistel proposed the use of a cipher that alternates substitutions and permutations, where these terms are defined as follows:

- **Substitution:** Each plaintext element or group of elements is uniquely replaced by a corresponding ciphertext element or group of elements.
- **Permutation:** A sequence of plaintext elements is replaced by a permutation of that sequence. That is, no elements are added or deleted or replaced in the sequence, rather the order in which the elements appear in the sequence is changed.

In fact, Feistel's is a practical application of a proposal by Claude Shannon to develop a product cipher that alternates *confusion* and *diffusion* functions [SHAN49].² We look next at these concepts of diffusion and confusion and then present the Feistel cipher. But first, it is worth commenting on this remarkable fact: The Feistel cipher structure, which dates back over a quarter century and which, in turn, is based on Shannon's proposal of 1945, is the structure used by a number of significant symmetric block ciphers currently in use. In particular, the Feistel structure is used for Triple Data Encryption Algorithm (TDEA), which is one of the two encryption algorithms (along with AES), approved for general use by the National Institute of Standards and Technology (NIST). The Feistel structure is also used for several schemes for format-preserving encryption, which have recently come into prominence. In addition, the Camellia block cipher is a Feistel structure; it is one of the possible symmetric ciphers in TLS and a number of other Internet security protocols. Both TDEA and format-preserving encryption are covered in Chapter 7.

DIFFUSION AND CONFUSION The terms *diffusion* and *confusion* were introduced by Claude Shannon to capture the two basic building blocks for any cryptographic system [SHAN49]. Shannon's concern was to thwart cryptanalysis based on statistical analysis. The reasoning is as follows. Assume the attacker has some knowledge of the statistical characteristics of the plaintext. For example, in a human-readable message in some language, the frequency distribution of the various letters may be known. Or there may be words or phrases likely to appear in the message (probable words). If these statistics are in any way reflected in the ciphertext, the cryptanalyst may be able to deduce the encryption key, part of the key, or at least a set of keys likely to contain the exact key. In what Shannon refers to as a strongly ideal cipher, all statistics of the ciphertext are independent of the particular key used. The arbitrary substitution cipher that we discussed previously (Figure 4.2) is such a cipher, but as we have seen, it is impractical.³

Other than recourse to ideal systems, Shannon suggests two methods for frustrating statistical cryptanalysis: diffusion and confusion. In **diffusion**, the statistical structure of the plaintext is dissipated into long-range statistics of the ciphertext. This is achieved by having each plaintext digit affect the value of many ciphertext digits; generally, this is equivalent to having each ciphertext digit be affected by many plaintext digits. An example of diffusion is to encrypt a message $M = m_1, m_2, m_3, \dots$ of characters with an averaging operation:

$$y_n = \left(\sum_{i=1}^k m_{n+i} \right) \bmod 26$$

²The paper is available at box.com/Crypto8e. Shannon's 1949 paper appeared originally as a classified report in 1945. Shannon enjoys an amazing and unique position in the history of computer and information science. He not only developed the seminal ideas of modern cryptography but is also responsible for inventing the discipline of information theory. Based on his work in information theory, he developed a formula for the capacity of a data communications channel, which is still used today. In addition, he founded another discipline, the application of Boolean algebra to the study of digital circuits; this last he managed to toss off as a master's thesis.

³Appendix B expands on Shannon's concepts concerning measures of secrecy and the security of cryptographic algorithms.

adding k successive letters to get a ciphertext letter y_n . One can show that the statistical structure of the plaintext has been dissipated. Thus, the letter frequencies in the ciphertext will be more nearly equal than in the plaintext; the digram frequencies will also be more nearly equal, and so on. In a binary block cipher, diffusion can be achieved by repeatedly performing some permutation on the data followed by applying a function to that permutation; the effect is that bits from different positions in the original plaintext contribute to a single bit of ciphertext.⁴

Every block cipher involves a transformation of a block of plaintext into a block of ciphertext, where the transformation depends on the key. The mechanism of diffusion seeks to make the statistical relationship between the plaintext and ciphertext as complex as possible in order to thwart attempts to deduce the key. On the other hand, **confusion** seeks to make the relationship between the statistics of the ciphertext and the value of the encryption key as complex as possible, again to thwart attempts to discover the key. Thus, even if the attacker can get some handle on the statistics of the ciphertext, the way in which the key was used to produce that ciphertext is so complex as to make it difficult to deduce the key. This is achieved by the use of a complex substitution algorithm. In contrast, a simple linear substitution function would add little confusion.

As [ROBS95b] points out, so successful are diffusion and confusion in capturing the essence of the desired attributes of a block cipher that they have become the cornerstone of modern block cipher design.

FEISTEL CIPHER STRUCTURE The left-hand side of Figure 4.3 depicts the encryption structure proposed by Feistel. The inputs to the encryption algorithm are a plaintext block of length $2w$ bits and a key K . The plaintext block is divided into two halves, LE_0 and RE_0 . The two halves of the data pass through n rounds of processing and then combine to produce the ciphertext block. Each round i has as inputs LE_{i-1} and RE_{i-1} derived from the previous round, as well as a **subkey** K_i derived from the overall K . In general, the subkeys K_i are different from K and from each other. In Figure 4.3, 16 rounds are used, although any number of rounds could be implemented.

All rounds have the same structure. A **substitution** is performed on the left half of the data. This is done by applying a **round function** F to the right half of the data and then taking the exclusive-OR of the output of that function and the left half of the data. The round function has the same general structure for each round but is parameterized by the round subkey K_i . Another way to express this is to say that F is a function of right-half block of w bits and a subkey of y bits, which produces an output value of length w bits: $F(RE_i, K_{i+1})$. Following this substitution, a **permutation** is performed that consists of the interchange of the two halves of the data.⁵ This structure is a particular form of the substitution-permutation network (SPN) proposed by Shannon.

⁴Some books on cryptography equate permutation with diffusion. This is incorrect. Permutation, *by itself*, does not change the statistics of the plaintext at the level of individual letters or permuted blocks. For example, in DES, the permutation swaps two 32-bit blocks, so statistics of strings of 32 bits or less are preserved.

⁵The final round is followed by an interchange that undoes the interchange that is part of the final round. One could simply leave both interchanges out of the diagram, at the sacrifice of some consistency of presentation. In any case, the effective lack of a swap in the final round is done to simplify the implementation of the decryption process, as we shall see.

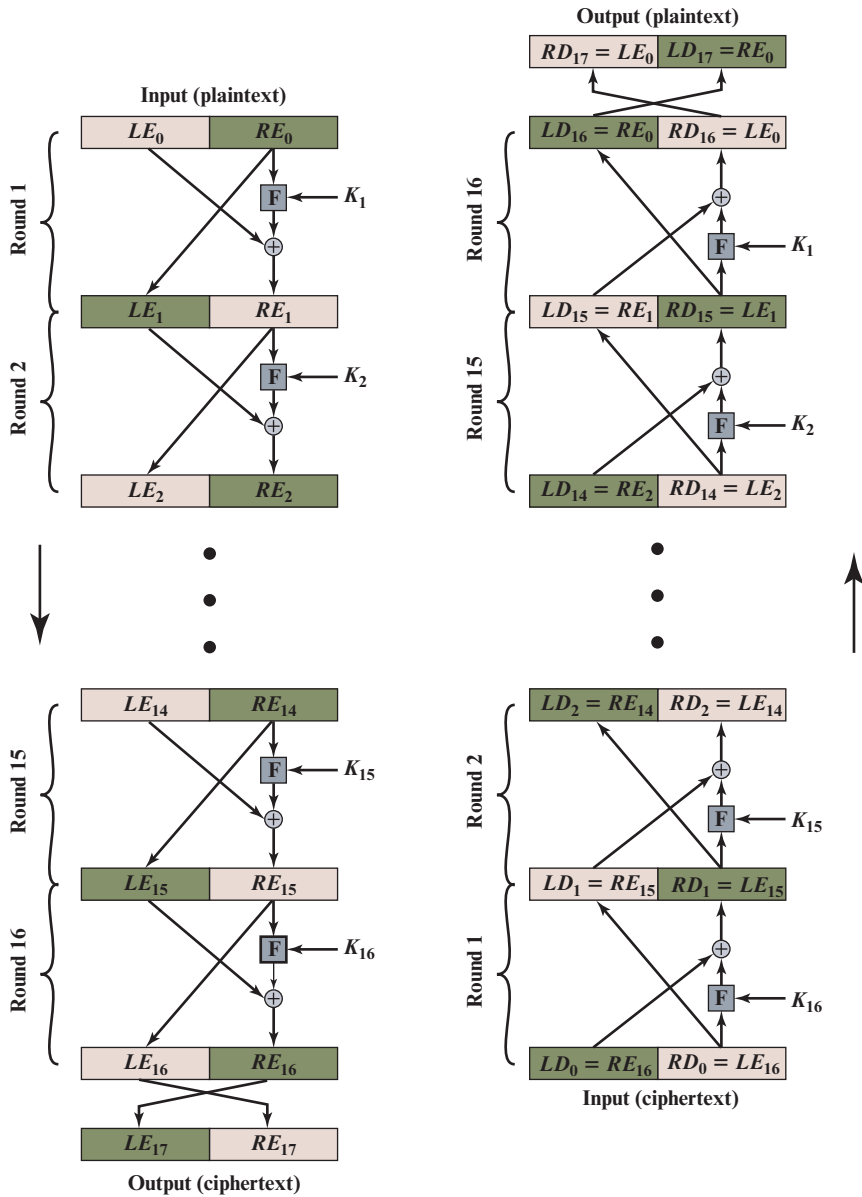

Figure 4.3 Feistel Encryption and Decryption (16 rounds)

The exact realization of a Feistel network depends on the choice of the following parameters and design features:

- Block size:** Larger block sizes mean greater security (all other things being equal) but reduced encryption/decryption speed for a given algorithm. The greater security is achieved by greater diffusion. Traditionally, a block size of 64 bits has been considered a reasonable tradeoff and was nearly universal in block cipher design. However, the new AES uses a 128-bit block size.

- **Key size:** Larger key size means greater security but may decrease encryption/decryption speed. The greater security is achieved by greater resistance to brute-force attacks and greater confusion. Key sizes of 64 bits or less are now widely considered to be inadequate, and 128 bits has become a common size.
- **Number of rounds:** The essence of the Feistel cipher is that a single round offers inadequate security but that multiple rounds offer increasing security. A typical size is 16 rounds.
- **Subkey generation algorithm:** Greater complexity in this algorithm should lead to greater difficulty of cryptanalysis.
- **Round function F:** Again, greater complexity generally means greater resistance to cryptanalysis.

There are two other considerations in the design of a Feistel cipher:

- **Fast software encryption/decryption:** In many cases, encryption is embedded in applications or utility functions in such a way as to preclude a hardware implementation. Accordingly, the speed of execution of the algorithm becomes a concern.
- **Ease of analysis:** Although we would like to make our algorithm as difficult as possible to cryptanalyze, there is great benefit in making the algorithm easy to analyze. That is, if the algorithm can be concisely and clearly explained, it is easier to analyze that algorithm for cryptanalytic vulnerabilities and therefore develop a higher level of assurance as to its strength. DES, for example, does not have an easily analyzed functionality.

FEISTEL DECRYPTION ALGORITHM The process of decryption with a Feistel cipher is essentially the same as the encryption process. The rule is as follows: Use the ciphertext as input to the algorithm, but use the subkeys K_i in reverse order. That is, use K_n in the first round, K_{n-1} in the second round, and so on, until K_1 is used in the last round. This is a nice feature, because it means we need not implement two different algorithms; one for encryption and one for decryption.

To see that the same algorithm with a reversed key order produces the correct result, Figure 4.3 shows the encryption process going down the left-hand side and the decryption process going up the right-hand side for a 16-round algorithm. For clarity, we use the notation LE_i and RE_i for data traveling through the encryption algorithm and LD_i and RD_i for data traveling through the decryption algorithm. The diagram indicates that, at every round, the intermediate value of the decryption process is equal to the corresponding value of the encryption process with the two halves of the value swapped. To put this another way, let the output of the i th encryption round be $LE_i || RE_i$ (LE_i concatenated with RE_i). Then the corresponding output of the $(16 - i)$ th decryption round is $RE_i || LE_i$ or, equivalently, $LD_{16-i} || RD_{16-i}$.

Let us walk through Figure 4.3 to demonstrate the validity of the preceding assertions. After the last iteration of the encryption process, the two halves of the output are swapped, so that the ciphertext is $RE_{16} || LE_{16}$. The output of that round is the ciphertext. Now take that ciphertext and use it as input to the same algorithm. The input to the first round is $RE_{16} || LE_{16}$, which is equal to the 32-bit swap of the output of the sixteenth round of the encryption process.

Now we would like to show that the output of the first round of the decryption process is equal to a 32-bit swap of the input to the sixteenth round of the encryption process. First, consider the encryption process. We see that

$$\begin{aligned} LE_{16} &= RE_{15} \\ RE_{16} &= LE_{15} \oplus F(RE_{15}, K_{16}) \end{aligned}$$

On the decryption side,

$$\begin{aligned} LD_1 &= RD_0 = LE_{16} = RE_{15} \\ RD_1 &= LD_0 \oplus F(RD_0, K_{16}) \\ &= RE_{16} \oplus F(RE_{15}, K_{16}) \\ &= [LE_{15} \oplus F(RE_{15}, K_{16})] \oplus F(RE_{15}, K_{16}) \end{aligned}$$

The XOR has the following properties:

$$\begin{aligned} [A \oplus B] \oplus C &= A \oplus [B \oplus C] \\ D \oplus D &= 0 \\ E \oplus 0 &= E \end{aligned}$$

Thus, we have $LD_1 = RE_{15}$ and $RD_1 = LE_{15}$. Therefore, the output of the first round of the decryption process is $RE_{15} \parallel LE_{15}$, which is the 32-bit swap of the input to the sixteenth round of the encryption. This correspondence holds all the way through the 16 iterations, as is easily shown. We can cast this process in general terms. For the i th iteration of the encryption algorithm,

$$\begin{aligned} LE_i &= RE_{i-1} \\ RE_i &= LE_{i-1} \oplus F(RE_{i-1}, K_i) \end{aligned}$$

Rearranging terms:

$$\begin{aligned} RE_{i-1} &= LE_i \\ LE_{i-1} &= RE_i \oplus F(RE_{i-1}, K_i) = RE_i \oplus F(LE_i, K_i) \end{aligned}$$

Thus, we have described the inputs to the i th iteration as a function of the outputs, and these equations confirm the assignments shown in the right-hand side of Figure 4.3.

Finally, we see that the output of the last round of the decryption process is $RE_0 \parallel LE_0$. A 32-bit swap recovers the original plaintext, demonstrating the validity of the Feistel decryption process.

Note that the derivation does not require that F be a reversible function. To see this, take a limiting case in which F produces a constant output (e.g., all ones) regardless of the values of its two arguments. The equations still hold.

To help clarify the preceding concepts, let us look at a specific example (Figure 4.4) and focus on the fifteenth round of encryption, corresponding to the second round of decryption. Suppose that the blocks at each stage are 32 bits (two 16-bit halves) and that the key size is 24 bits. Suppose that at the end of encryption round fourteen, the value of the intermediate block (in hexadecimal) is DE7F03A6. Then $LE_{14} = \text{DE7F}$ and $RE_{14} = \text{03A6}$. Also assume that the value of K_{15} is 12DE52. After round 15, we have $LE_{15} = \text{03A6}$ and $RE_{15} = F(\text{03A6}, \text{12DE52}) \oplus \text{DE7F}$.



Figure 4.4 Feistel Example

Now let’s look at the decryption. We assume that $LD_1 = RE_{15}$ and $RD_1 = LE_{15}$, as shown in Figure 4.3, and we want to demonstrate that $LD_2 = RE_{14}$ and $RD_2 = LE_{14}$. So, we start with $LD_1 = F(03A6, 12DE52) \oplus DE7F$ and $RD_1 = 03A6$. Then, from Figure 4.3, $LD_2 = 03A6 = RE_{14}$ and $RD_2 = F(03A6, 12DE52) \oplus [F(03A6, 12DE52) \oplus DE7F] = DE7F = LE_{14}$.

4.2 THE DATA ENCRYPTION STANDARD

Until the introduction of the Advanced Encryption Standard (AES) in 2001, the Data Encryption Standard (DES) was the most widely used encryption scheme. DES was issued in 1977 by the National Bureau of Standards, now the National Institute of Standards and Technology (NIST), as Federal Information Processing Standard 46 (FIPS PUB 46). The algorithm itself is referred to as the Data Encryption Algorithm (DEA).⁶ For DEA, data are encrypted in 64-bit blocks using a 56-bit key. The algorithm transforms 64-bit input in a series of steps into a 64-bit output. The same steps, with the same key, are used to reverse the encryption.

Over the years, DES became the dominant symmetric encryption algorithm, especially in financial applications. In 1994, NIST reaffirmed DES for federal use for another five years; NIST recommended the use of DES for applications other than the protection of classified information. In 1999, NIST issued a new version of its standard (FIPS PUB 46-3) that indicated that DES should be used only for legacy systems and that triple DES (which in essence involves repeating the DES algorithm three times on the plaintext using two or three different keys to produce the ciphertext) be used. We study triple DES in Chapter 7. Because the underlying encryption and decryption algorithms are the same for DES and triple DES, it remains important to understand the DES cipher. This section provides an overview. For the interested reader, Appendix C provides further detail.

⁶The terminology is a bit confusing. Until recently, the terms *DES* and *DEA* could be used interchangeably. However, the most recent edition of the DES document includes a specification of the DEA described here plus the triple DEA (TDEA) described in Chapter 7. Both DEA and TDEA are part of the Data Encryption Standard. Further, until the recent adoption of the official term *TDEA*, the triple DEA algorithm was typically referred to as *triple DES* and written as 3DES. For the sake of convenience, we will use the term 3DES.

DES Encryption

The overall scheme for DES encryption is illustrated in Figure 4.5. As with any encryption scheme, there are two inputs to the encryption function: the plaintext to be encrypted and the key. In this case, the plaintext must be 64 bits in length and the key is 56 bits in length.⁷

Looking at the left-hand side of the figure, we can see that the processing of the plaintext proceeds in three phases. First, the 64-bit plaintext passes through an initial permutation (IP) that rearranges the bits to produce the *permuted input*.

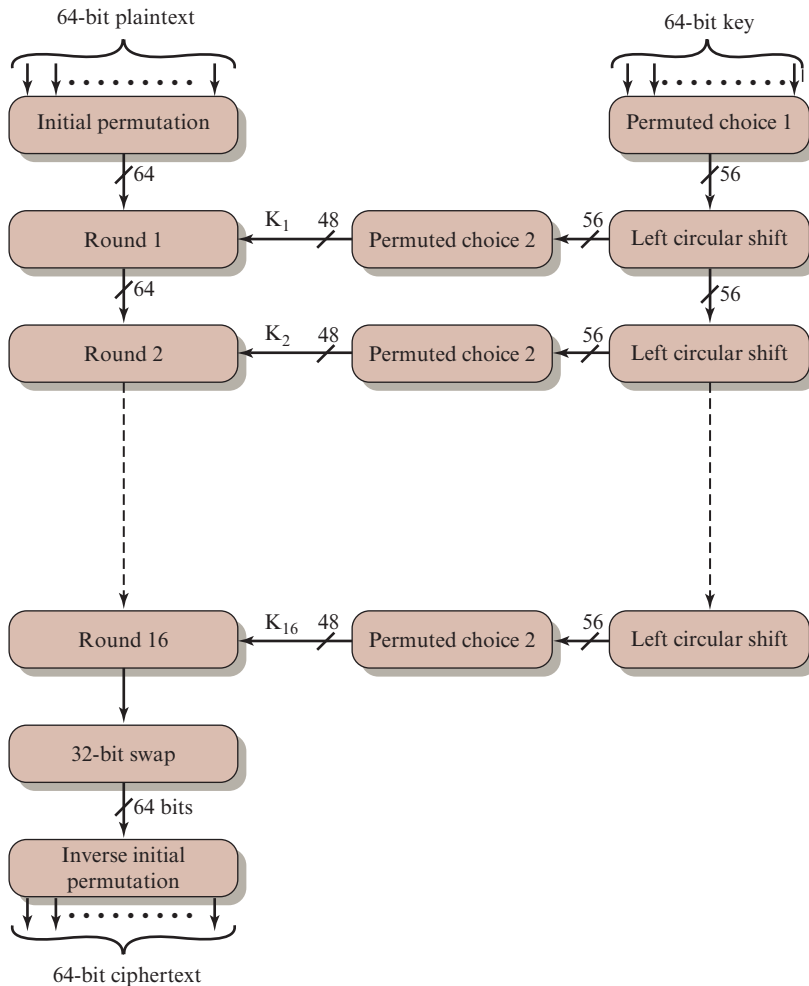

Figure 4.5 General Depiction of DES Encryption Algorithm

⁷Actually, the function expects a 64-bit key as input. However, only 56 of these bits are ever used; the other 8 bits can be used as parity bits or simply set arbitrarily.

This is followed by a phase consisting of sixteen rounds of the same function, which involves both permutation and substitution functions. The output of the last (sixteenth) round consists of 64 bits that are a function of the input plaintext and the key. The left and right halves of the output are swapped to produce the **preoutput**. Finally, the preoutput is passed through a permutation $[IP^{-1}]$ that is the inverse of the initial permutation function, to produce the 64-bit ciphertext. With the exception of the initial and final permutations, DES has the exact structure of a Feistel cipher, as shown in Figure 4.3.

The right-hand portion of Figure 4.5 shows the way in which the 56-bit key is used. Initially, the key is passed through a permutation function. Then, for each of the sixteen rounds, a *subkey* (K_i) is produced by the combination of a left circular shift and a permutation. The permutation function is the same for each round, but a different subkey is produced because of the repeated shifts of the key bits.

DES Decryption

As with any Feistel cipher, decryption uses the same algorithm as encryption, except that the application of the subkeys is reversed. Additionally, the initial and final permutations are reversed.

4.3 A DES EXAMPLE

We now work through an example and consider some of its implications. Although you are not expected to duplicate the example by hand, you will find it informative to study the hex patterns that occur from one step to the next.

For this example, the plaintext is a hexadecimal palindrome. The plaintext, key, and resulting ciphertext are as follows:

Plaintext:	02468aceeca86420
Key:	0f1571c947d9e859
Ciphertext:	da02ce3a89ecac3b

Results

Table 4.2 shows the progression of the algorithm. The first row shows the 32-bit values of the left and right halves of data after the initial permutation. The next 16 rows show the results after each round. Also shown is the value of the 48-bit subkey generated for each round. Note that $L_i = R_{i-1}$. The final row shows the left- and right-hand values after the inverse initial permutation. These two values combined form the ciphertext.

The Avalanche Effect

A desirable property of any encryption algorithm is that a small change in either the plaintext or the key should produce a significant change in the ciphertext. In particular, a change in one bit of the plaintext or one bit of the key should produce

Table 4.2 DES Example

Round	K_i	L_i	R_i
IP		5a005a00	3cf03c0f
1	1e030f03080d2930	3cf03c0f	bad22845
2	0a31293432242318	bad22845	99e9b723
3	23072318201d0c1d	99e9b723	0bae3b9e
4	05261d3824311a20	0bae3b9e	42415649
5	3325340136002c25	42415649	18b3fa41
6	123a2d0d04262a1c	18b3fa41	9616fe23
7	021f120b1c130611	9616fe23	67117cf2
8	1c10372a2832002b	67117cf2	c11bfc09
9	04292a380c341f03	c11bfc09	887fbc6c
10	2703212607280403	887fbc6c	600f7e8b
11	2826390c31261504	600f7e8b	f596506e
12	12071c241a0a0f08	f596506e	738538b8
13	300935393c0d100b	738538b8	c6a62c4e
14	311e09231321182a	c6a62c4e	56b0bd75
15	283d3e0227072528	56b0bd75	75e8fd8f
16	2921080b13143025	75e8fd8f	25896490
IP ⁻¹		da02ce3a	89ecac3b

Note: DES subkeys are shown as eight 6-bit values in hex format

a change in many bits of the ciphertext. This is referred to as the **avalanche effect**. If the change were small, this might provide a way to reduce the size of the plaintext or key space to be searched.

Using the example from Table 4.2, Table 4.3 shows the result when the fourth bit of the plaintext is changed, so that the plaintext is **12468aceeca86420**. The second column of the table shows the intermediate 64-bit values at the end of each round for the two plaintexts. The third column shows the number of bits that differ between the two intermediate values. The table shows that, after just three rounds, 18 bits differ between the two blocks. On completion, the two ciphertexts differ in 32 bit positions.

Table 4.4 shows a similar test using the original plaintext of with two keys that differ in only the fourth bit position: the original key, **0f1571c947d9e859**, and the altered key, **1f1571c947d9e859**. Again, the results show that about half of the bits in the ciphertext differ and that the avalanche effect is pronounced after just a few rounds.

Table 4.3 Avalanche Effect in DES: Change in Plaintext

Round		δ
	02468aceeca86420 12468aceeca86420	1
1	3cf03c0fbad22845 3cf03c0fbad32845	1
2	bad2284599e9b723 bad3284539a9b7a3	5
3	99e9b7230bae3b9e 39a9b7a3171cb8b3	18
4	0bae3b9e42415649 171cb8b3ccaca55e	34
5	4241564918b3fa41 ccaca55ed16c3653	37
6	18b3fa419616fe23 d16c3653cf402c68	33
7	9616fe2367117cf2 cf402c682b2cefbc	32
8	67117cf2c11bfc09 2b2cefbc99f91153	33

Round		δ
9	c11bfc09887fbc6c 99f911532eed7d94	32
10	887fbc6c600f7e8b 2eed7d94d0f23094	34
11	600f7e8bf596506e d0f23094455da9c4	37
12	f596506e738538b8 455da9c47f6e3cf3	31
13	738538b8c6a62c4e 7f6e3cf34bcl1a8d9	29
14	c6a62c4e56b0bd75 4bc1a8d91e07d409	33
15	56b0bd7575e8fd8f 1e07d4091ce2e6dc	31
16	75e8fd8f25896490 1ce2e6dc365e5f59	32
IP⁻¹	da02ce3a89ecac3b 057cde97d7683f2a	32

Table 4.4 Avalanche Effect in DES: Change in Key

Round		δ
	02468aceeca86420 02468aceeca86420	0
1	3cf03c0fbad22845 3cf03c0f9ad628c5	3
2	bad2284599e9b723 9ad628c59939136b	11
3	99e9b7230bae3b9e 9939136b768067b7	25
4	0bae3b9e42415649 768067b75a8807c5	29
5	4241564918b3fa41 5a8807c5488dbe94	26
6	18b3fa419616fe23 488dbe94aba7fe53	26
7	9616fe2367117cf2 aba7fe53177d21e4	27
8	67117cf2c11bfc09 177d21e4548f1de4	32

Round		δ
9	c11bfc09887fbc6c 548f1de471f64dfd	34
10	887fbc6c600f7e8b 71f64dfd4279876c	36
11	600f7e8bf596506e 4279876c399fdc0d	32
12	f596506e738538b8 399fdc0d6d208dbb	28
13	738538b8c6a62c4e 6d208dbbb9bdeaaa	33
14	c6a62c4e56b0bd75 b9bdeead2c3a56f	30
15	56b0bd7575e8fd8f d2c3a56f2765c1fb	27
16	75e8fd8f25896490 2765c1fb01263dc4	30
IP⁻¹	da02ce3a89ecac3b ee92b50606b62b0b	30

4.4 THE STRENGTH OF DES

Since its adoption as a federal standard, there have been lingering concerns about the level of security provided by DES. These concerns, by and large, fall into two areas: key size and the nature of the algorithm.

The Use of 56-Bit Keys

With a key length of 56 bits, there are 2^{56} possible keys, which is approximately 7.2×10^{16} keys. Thus, on the face of it, a brute-force attack appears impractical. Assuming that, on average, half the key space has to be searched, a single machine performing one DES encryption per microsecond would take more than a thousand years to break the cipher.

However, the assumption of one encryption per microsecond is overly conservative. As far back as 1977, Diffie and Hellman postulated that the technology existed to build a parallel machine with 1 million encryption devices, each of which could perform one encryption per microsecond [DIFF77]. This would bring the average search time down to about 10 hours. The authors estimated that the cost would be about \$20 million in 1977 dollars.

With current technology, it is not even necessary to use special, purpose-built hardware. Rather, the speed of commercial, off-the-shelf processors threaten the security of DES. A 2008 paper from Seagate Technology [SEAG08] suggests that a rate of 1 billion (10^9) key combinations per second is reasonable for today's multicore computers. Recent offerings confirm this. Both Intel and AMD now offer hardware-based instructions to accelerate the use of AES. Tests run on a contemporary multicore Intel machine resulted in an encryption rate of about half a billion encryptions per second [BASU12]. Another recent analysis suggests that with contemporary supercomputer technology, a rate of 10^{13} encryptions per second is reasonable [AROR12].

With these results in mind, Table 4.5 shows how much time is required for a brute-force attack for various key sizes. As can be seen, a single PC can break DES in about a year; if multiple PCs work in parallel, the time is drastically shortened. And today's supercomputers should be able to find a key in about an hour. Key sizes of 128 bits or greater are effectively unbreakable using simply a brute-force approach. Even if we managed to speed up the attacking system by a factor of 1 trillion (10^{12}), it would still take over 100,000 years to break a code using a 128-bit key.

Fortunately, there are a number of alternatives to DES, the most important of which are AES and triple DES, discussed in Chapters 6 and 7, respectively.

The Nature of the DES Algorithm

Another concern is the possibility that cryptanalysis is possible by exploiting the characteristics of the DES algorithm. The focus of concern has been on the eight substitution tables, or S-boxes, that are used in each iteration (described in Appendix C). Because the design criteria for these boxes, and indeed for the entire algorithm, were not made public, there is a suspicion that the boxes were constructed in such a way that cryptanalysis is possible for an opponent who knows the weaknesses in

Table 4.5 Average Time Required for Exhaustive Key Search

Key Size (bits)	Cipher	Number of Alternative Keys	Time Required at 10^9 Decryptions/s	Time Required at 10^{13} Decryptions/s
56	DES	$2^{56} \approx 7.2 \times 10^{16}$	2^{55} ns = 1.125 years	1 hour
128	AES	$2^{128} \approx 3.4 \times 10^{38}$	2^{127} ns = 5.3×10^{21} years	5.3×10^{17} years
168	Triple DES	$2^{168} \approx 3.7 \times 10^{50}$	2^{167} ns = 5.8×10^{33} years	5.8×10^{29} years
192	AES	$2^{192} \approx 6.3 \times 10^{57}$	2^{191} ns = 9.8×10^{40} years	9.8×10^{36} years
256	AES	$2^{256} \approx 1.2 \times 10^{77}$	2^{255} ns = 1.8×10^{60} years	1.8×10^{56} years
26 characters (permutation)	Monoalphabetic	$2! = 4 \times 10^{26}$	2×10^{26} ns = 6.3×10^9 years	6.3×10^6 years

the S-boxes. This assertion is tantalizing, and over the years a number of regularities and unexpected behaviors of the S-boxes have been discovered. Despite this, no one has so far succeeded in discovering the supposed fatal weaknesses in the S-boxes.⁸

Timing Attacks

We discuss timing attacks in more detail in Part Three, as they relate to public-key algorithms. However, the issue may also be relevant for symmetric ciphers. In essence, a timing attack is one in which information about the key or the plaintext is obtained by observing how long it takes a given implementation to perform decryptions on various ciphertexts. A timing attack exploits the fact that an encryption or decryption algorithm often takes slightly different amounts of time on different inputs. [HEVI99] reports on an approach that yields the Hamming weight (number of bits equal to one) of the secret key. This is a long way from knowing the actual key, but it is an intriguing first step. The authors conclude that DES appears to be fairly resistant to a successful timing attack but suggest some avenues to explore. Although this is an interesting line of attack, it so far appears unlikely that this technique will ever be successful against DES or more powerful symmetric ciphers such as triple DES and AES.

4.5 BLOCK CIPHER DESIGN PRINCIPLES

Although much progress has been made in designing block ciphers that are cryptographically strong, the basic principles have not changed all that much since the work of Feistel and the DES design team in the early 1970s. In this section we look at three critical aspects of block cipher design: the number of rounds, design of the function F, and key scheduling.

⁸At least, no one has publicly acknowledged such a discovery.

Number of Rounds

The cryptographic strength of a Feistel cipher derives from three aspects of the design: the number of rounds, the function F , and the key schedule algorithm. Let us look first at the choice of the number of rounds.

The greater the number of rounds, the more difficult it is to perform cryptanalysis, even for a relatively weak F . In general, the criterion should be that the number of rounds is chosen so that known cryptanalytic efforts require greater effort than a simple brute-force key search attack. This criterion was certainly used in the design of DES. Schneier [SCHN96] observes that for 16-round DES, a differential cryptanalysis attack is slightly less efficient than brute force: The differential cryptanalysis attack requires $2^{55.1}$ operations,⁹ whereas brute force requires 2^{55} . If DES had 15 or fewer rounds, differential cryptanalysis would require less effort than a brute-force key search.

This criterion is attractive, because it makes it easy to judge the strength of an algorithm and to compare different algorithms. In the absence of a cryptanalytic breakthrough, the strength of any algorithm that satisfies the criterion can be judged solely on key length.

Design of Function F

The heart of a Feistel block cipher is the function F , which provides the element of confusion in a Feistel cipher. Thus, it must be difficult to “unscramble” the substitution performed by F . One obvious criterion is that F be nonlinear, as we discussed previously. The more nonlinear F , the more difficult any type of cryptanalysis will be. There are several measures of nonlinearity, which are beyond the scope of this book. In rough terms, the more difficult it is to approximate F by a set of linear equations, the more nonlinear F is.

Several other criteria should be considered in designing F . We would like the algorithm to have good avalanche properties. Recall that, in general, this means that a change in one bit of the input should produce a change in many bits of the output. A more stringent version of this is the **strict avalanche criterion (SAC)** [WEBS86], which states that any output bit j of an S-box (see Appendix C for a discussion of S-boxes) should change with probability $1/2$ when any single input bit i is inverted for all i, j . Although SAC is expressed in terms of S-boxes, a similar criterion could be applied to F as a whole. This is important when considering designs that do not include S-boxes.

Another criterion proposed in [WEBS86] is the **bit independence criterion (BIC)**, which states that output bits j and k should change independently when any single input bit i is inverted for all i, j , and k . The SAC and BIC criteria appear to strengthen the effectiveness of the confusion function.

⁹Differential cryptanalysis of DES requires 2^{47} chosen plaintext. If all you have to work with is known plaintext, then you must sort through a large quantity of known plaintext–ciphertext pairs looking for the useful ones. This brings the level of effort up to $2^{55.1}$.

Key Schedule Algorithm

With any Feistel block cipher, the key is used to generate one subkey for each round. In general, we would like to select subkeys to maximize the difficulty of deducing individual subkeys and the difficulty of working back to the main key. No general principles for this have yet been promulgated.

Adams suggests [ADAM94] that, at minimum, the key schedule should guarantee key/ciphertext Strict Avalanche Criterion and Bit Independence Criterion.

4.6 KEY TERMS, REVIEW QUESTIONS, AND PROBLEMS

Key Terms

avalanche effect block cipher confusion diffusion Feistel cipher	irreversible mapping permutation product cipher reversible mapping round	round function stream cipher subkey substitution
--	--	---

Review Questions

- 4.1 Briefly define a nonsingular transformation.
- 4.2 What is the difference between a block cipher and a stream cipher?
- 4.3 Why is it not practical to use an arbitrary reversible substitution cipher of the kind shown in Table 4.1?
- 4.4 Briefly define the terms substitution and permutation.
- 4.5 What is the strict avalanche criterion for the Feistel F function?
- 4.6 Which parameters and design choices determine the actual algorithm of a Feistel cipher?
- 4.7 What are the critical aspects of Feistel cipher design?

Problems

- 4.1 a. In Section 4.1, under the subsection on Feistel decryption algorithm, it is mentioned that the decryption algorithm is essentially the same as the encryption algorithm except that the subkeys are used in reverse order. Justify this statement.
 - b. In the same discussion, it was stated that the F function is not required to be reversible for the correctness of the algorithm. The statement holds for an F function that always produces a constant output. Will the claim still hold if F does not always produce a constant output? Justify your answer.

- 4.2 Consider a Feistel cipher composed of sixteen rounds with a block length of 128 bits and a key length of 128 bits. Suppose that, for a given k , the key scheduling algorithm determines values for the first eight round keys, k_1, k_2, \dots, k_8 , and then sets

$$k_9 = k_8, k_{10} = k_7, k_{11} = k_6, \dots, k_{16} = k_1$$

Suppose you have a ciphertext c . Explain how, with access to an encryption oracle, you can decrypt c and determine m using just a single oracle query. This shows that such a cipher is vulnerable to a chosen plaintext attack. (An encryption oracle can be thought of as a device that, when given a plaintext, returns the corresponding ciphertext. The internal details of the device are not known to you and you cannot break open the device. You can only gain information from the oracle by making queries to it and observing its responses.)

- 4.3 Let π be a permutation of the integers $0, 1, 2, \dots, (2^n - 1)$, such that $\pi(m)$ gives the permuted value of m , $0 \leq m < 2^n$. Put another way, π maps the set of n -bit integers onto itself, and no two integers map into the same integer. DES is such a permutation for 64-bit integers. We say that π has a fixed point at m if $\pi(m) = m$. That is, if π is an encryption mapping, then a fixed point corresponds to a message that encrypts to itself. We are interested in the number of fixed points in a randomly chosen permutation π . Show the somewhat unexpected result that the number of fixed points for π is 1 on an average, and this number is independent of the size of the permutation.
- 4.4 Consider a block encryption algorithm that encrypts blocks of length n , and let $N = 2^n$. Say we have t plaintext-ciphertext pairs $P_i, C_i = E(K, P_i)$, where we assume that the key K is a randomly chosen m -bit string. Imagine that we wish to find K by exhaustive search. We could generate key K' and test whether $C_i = E(K', P_i)$ for $1 \dots i \dots t$. If K' encrypts each P_i to its proper C_i , then we have evidence that $K = K'$. However, it may be the case that the mappings $E(K, \cdot)$ and $E(K', \cdot)$ exactly agree on the t plaintext-ciphertext pairs P_i, C_i and agree on no other pairs. Such keys are called *spurious keys*.
- What is the probability that $E(K, \cdot)$ and $E(K', \cdot)$ agree on exactly t plaintext-ciphertext pairs?
 - Find the expected number of spurious keys when $E(K, \cdot)$ and $E(K', \cdot)$ agree on exactly t plaintext-ciphertext pairs.
- 4.5 For any block cipher, the fact that it is a nonlinear function is crucial to its security. To see this, suppose that we have a linear block cipher EL that encrypts 256-bit blocks of plaintext into 256-bit blocks of ciphertext. Let $EL(k, m)$ denote the encryption of a 256-bit message m under a key k (the actual bit length of k is irrelevant). Thus,

$$EL(k, [m_1 \oplus m_2]) = EL(k, m_1) \oplus EL(k, m_2) \text{ for all 128-bit patterns } m_1, m_2.$$

Describe how, with 256 chosen ciphertexts, an adversary can decrypt any ciphertext without knowledge of the secret key k . (A “chosen ciphertext” means that an adversary has the ability to choose a ciphertext and then obtain its decryption. Here, you have 256 plaintext/ciphertext pairs to work with, and you have the ability to choose the value of the ciphertexts.)

- 4.6 Suppose the DES F function mapped every 32-bit input R , regardless of the value of the input K , to
- a 32-bit string of zero, and
 - R .

Then:

- What function would DES compute?
- What would the decryption look like?

Hint: Use the following properties of the XOR operation:

$$(A \oplus B) \oplus C = A \oplus (B \oplus C)$$

$$(A \oplus A) = 0$$

$$(A \oplus 0) = A$$

$$A \oplus 1 = \text{bitwise complement of } A$$

- 4.7** Show that DES decryption is, in fact, the inverse of DES encryption.
- 4.8** The 32-bit swap after the sixteenth iteration of the DES algorithm is needed to make the encryption process invertible by simply running the ciphertext back through the algorithm with the key order reversed. This was demonstrated in the preceding problem. However, it still may not be entirely clear why the 32-bit swap is needed. To demonstrate why, solve the following exercises. First, some notation:

$A\|B$ = the concatenation of the bit strings A and B

$T_i(R\|L)$ = the transformation defined by the i th iteration of the encryption algorithm for $1 \leq i \leq 16$

$TD_i(R\|L)$ = the transformation defined by the i th iteration of the decryption algorithm for $1 \leq i \leq 16$

$T_{17}(R\|L) = L\|R$, where this transformation occurs after the sixteenth iteration of the encryption algorithm

- a.** Show that the composition $TD_1(IP(IP^{-1}(T_{17}(T_{16}(L_{15}\|R_{15}))))))$ is equivalent to the transformation that interchanges the 32-bit halves, L_{15} and R_{15} . That is, show that

$$TD_1(IP(IP^{-1}(T_{17}(T_{16}(L_{15}\|R_{15})))))) = R_{15}\|L_{15}$$

- b.** Now suppose that we did away with the final 32-bit swap in the encryption algorithm. Then we would want the following equality to hold:

$$TD_1(IP(IP^{-1}(T_{16}(L_{15}\|R_{15})))) = L_{15}\|R_{15}$$

Does it?

Note: The following problems refer to details of DES that are described in Appendix C.

- 4.9** Consider the substitution defined by row 1 of S-box S_1 in Table C.2. Show a block diagram similar to Figure 4.2 that corresponds to this substitution.
- 4.10** Compute the bits number 4, 17, 41, and 45 at the output of the first round of the DES decryption, assuming that the ciphertext block is composed of all ones, and the external key is composed of all ones.
- 4.11** This problem provides a numerical example of encryption using a one-round version of DES. We start with the same bit pattern for the key K and the plaintext, namely:

Hexadecimal notation: 0 1 2 3 4 5 6 7 8 9 A B C D E F

Binary notation: 0000 0001 0010 0011 0100 0101 0110 0111
1000 1001 1010 1011 1100 1101 1110 1111

- a.** Derive K_1 , the first-round subkey.
- b.** Derive L_0, R_0 .
- c.** Expand R_0 to get $E[R_0]$, where $E[\cdot]$ is the expansion function of Table C.1.
- d.** Calculate $A = E[R_0] \oplus K_1$.
- e.** Group the 48-bit result of (d) into sets of 6 bits and evaluate the corresponding S-box substitutions.
- f.** Concatenate the results of (e) to get a 32-bit result, B .

- g. Apply the permutation to get $P(B)$.
 - h. Calculate $R_1 = P(B) \oplus L_0$.
 - i. Write down the ciphertext.
- 4.12 Analyze the amount of left shifts in the DES key schedule by studying Table C.3 (d). Is there a pattern? What could be the reason for the choice of these constants?
- 4.13 Suppose that a modern multi-core computer can process 10^9 key combinations per second. How much time will it take to search the key space of an encryption algorithm that has a 56-bit key? If the key size is increased to 60 bits but the CPU speed is also doubled, then how much time will the key search take on the new computer?
- 4.14 a. Let X' be the bitwise complement of X . Prove that if the complement of the plaintext block is taken and the complement of an encryption key is taken, then the result of DES encryption with these values is the complement of the original ciphertext. That is,

$$\begin{array}{lcl} \text{If} & Y & = & E(K, X) \\ \text{Then} & Y' & = & E(K', X') \end{array}$$

Hint: Begin by showing that for any two bit strings of equal length, A and B , $(A \oplus B)' = A' \oplus B$.

- b. It has been said that a brute-force attack on DES requires searching a key space of 2^{56} keys. Does the result of part (a) change that?
- 4.15 a. We say that a DES key K is weak if DES_K is an involution. Exhibit four weak keys for DES.
- b. We say that a DES key K is semi-weak if it is not weak and if there exists a key K' such that $\text{DES}_K^{-1} = \text{DES}_{K'}$. Exhibit four semi-weak keys for DES.

Programming Problems

- 4.1 Create software that can encrypt and decrypt using a general substitution block cipher.
- 4.2 Create software that can encrypt and decrypt using S-DES.

FINITE FIELDS

5.1 Groups

- Groups
- Abelian Group
- Cyclic Group

5.2 Rings

5.3 Fields

5.4 Finite Fields of the Form $\text{GF}(p)$

- Finite Fields of Order p
- Finding the Multiplicative Inverse in $\text{GF}(p)$
- Summary

5.5 Polynomial Arithmetic

- Ordinary Polynomial Arithmetic
- Polynomial Arithmetic with Coefficients in \mathbb{Z}_p
- Finding the Greatest Common Divisor
- Summary

5.6 Finite Fields of the Form $\text{GF}(2^n)$

- Motivation
- Modular Polynomial Arithmetic
- Finding the Multiplicative Inverse
- Computational Considerations
- Using a Generator
- Summary

5.7 Key Terms, Review Questions, and Problems

LEARNING OBJECTIVES

After studying this chapter, you should be able to:

- ◆ Distinguish among groups, rings, and fields.
- ◆ Define finite fields of the form $\text{GF}(p)$.
- ◆ Explain the differences among ordinary polynomial arithmetic, polynomial arithmetic with coefficients in \mathbb{Z}_p , and modular polynomial arithmetic in $\text{GF}(2^n)$.
- ◆ Define finite fields of the form $\text{GF}(2^n)$.
- ◆ Explain the two different uses of the mod operator.

Finite fields have become increasingly important in cryptography. A number of cryptographic algorithms rely heavily on properties of finite fields, notably the Advanced Encryption Standard (AES) and elliptic curve cryptography. Other examples include the message authentication code CMAC and the authenticated encryption scheme GCM.

This chapter provides the reader with sufficient background on the concepts of finite fields to be able to understand the design of AES and other cryptographic algorithms that use finite fields. Because students unfamiliar with abstract algebra may find the concepts behind finite fields somewhat difficult to grasp, we approach the topic in a way designed to enhance understanding. Our plan of attack is as follows:

1. Fields are a subset of a larger class of algebraic structures called rings, which are in turn a subset of the larger class of groups. In fact, as shown in Figure 5.1, both groups and rings can be further differentiated. Groups are defined by a simple set of properties and are easily understood. Each successive subset (abelian group, ring, commutative ring, and so on) adds additional properties and is thus more complex. Sections 5.1 through 5.3 will examine groups, rings, and fields, successively.
2. **Finite fields** are a subset of fields, consisting of those fields with a finite number of elements. These are the class of fields that are found in cryptographic algorithms. With the concepts of fields in hand, we turn in Section 5.4 to a specific class of finite fields, namely those with p elements, where p is prime. Certain asymmetric cryptographic algorithms make use of such fields.
3. A more important class of finite fields, for cryptography, comprises those with 2^n elements depicted as fields of the form $\text{GF}(2^n)$. These are used in a wide variety of cryptographic algorithms. However, before discussing these fields, we need to analyze the topic of polynomial arithmetic, which is done in Section 5.5.
4. With all of this preliminary work done, we are able at last, in Section 5.6, to discuss finite fields of the form $\text{GF}(2^n)$.

Before proceeding, the reader may wish to review Sections 2.1 through 2.3, which cover relevant topics in number theory.

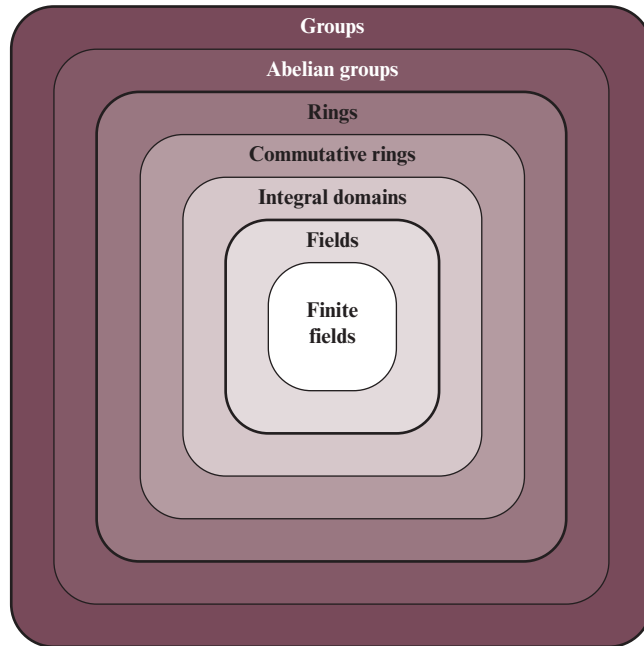

Figure 5.1 Groups, Rings, and Fields

5.1 GROUPS

Groups, rings, and fields are the fundamental elements of a branch of mathematics known as abstract algebra, or modern algebra. In abstract algebra, we are concerned with sets on whose elements we can operate algebraically; that is, we can combine two elements of the set, perhaps in several ways, to obtain a third element of the set. These operations are subject to specific rules, which define the nature of the set. By convention, the notation for the two principal classes of operations on set elements is usually the same as the notation for addition and multiplication on ordinary numbers. However, it is important to note that, in abstract algebra, we are not limited to basic arithmetical operations. All this should become clear as we proceed.

Groups

A group G , sometimes denoted by $\{G, \cdot\}$, is a set of elements with a binary operation denoted by \cdot that associates to each ordered pair (a, b) of elements in G an element $(a \cdot b)$ in $G \times G$, such that the following axioms are obeyed:¹

- | | |
|--------------------------|--|
| (A1) Closure: | If a and b belong to G , then $a \cdot b$ is also in G . |
| (A2) Associative: | $a \cdot (b \cdot c) = (a \cdot b) \cdot c$ for all a, b, c in G . |

¹The operator \cdot is generic and can refer to addition, multiplication, or some other mathematical operation.

- (A3) Identity element:** There is an element e in G such that $a \cdot e = e \cdot a = a$ for all a in G .
- (A4) Inverse element:** For each a in G , there is an element a' in G such that $a \cdot a' = a' \cdot a = e$.

Let N_n denote a set of n distinct symbols that, for convenience, we represent as $\{1, 2, \dots, n\}$. A **permutation** of n distinct symbols is a one-to-one mapping from N_n on to N_n .² Define S_n to be the set of all permutations of n distinct symbols. Each element of S_n is represented by a permutation π of the integers in $1, 2, \dots, n$. It is easy to demonstrate that S_n is a group:

- A1:** If $(\pi, \rho \in S_n)$, then the composite mapping $\pi \cdot \rho$ is formed by permuting the elements of ρ according to the permutation π . For example, $\{3, 2, 1\} \cdot \{1, 3, 2\} = \{2, 3, 1\}$. The notation for this mapping is explained as follows: The value of the first element of π indicates which element of ρ is to be in the first position in $\pi \cdot \rho$; the value of the second element of π indicates which element of ρ is to be in the second position in $\pi \cdot \rho$; and so on. Clearly, $\pi \cdot \rho \in S_n$.
- A2:** The composition of mappings is also easily seen to be associative.
- A3:** The identity mapping is the permutation that does not alter the order of the n elements. For S_n , the identity element is $\{1, 2, \dots, n\}$.
- A4:** For any $\pi \in S_n$, the mapping that undoes the permutation defined by π is the inverse element for π . There will always be such an inverse. For example $\{2, 3, 1\} \cdot \{3, 1, 2\} = \{1, 2, 3\}$.

If a group has a finite number of elements, it is referred to as a finite group, and the **order** of the group is equal to the number of elements in the group. Otherwise, the group is an infinite group.

Abelian Group

A group is said to be abelian if it satisfies the following additional condition:

- (A5) Commutative:** $a \cdot b = b \cdot a$ for all a, b in G .

The set of integers (positive, negative, and 0) under addition is an abelian group. The set of nonzero real numbers under multiplication is an abelian group. The set S_n from the preceding example is a group but not an abelian group for $n > 2$.

²This is equivalent to the definition of permutation in Chapter 2, which stated that a permutation of a finite set of elements S is an ordered sequence of all the elements of S , with each element appearing exactly once.

When the group operation is addition, the identity element is 0; the inverse element of a is $-a$; and subtraction is defined with the following rule: $a - b = a + (-b)$.

Cyclic Group

We define exponentiation within a group as a repeated application of the group operator, so that $a^3 = a \cdot a \cdot a$. Furthermore, we define $a^0 = e$ as the identity element, and $a^{-n} = (a')^n$, where a' is the inverse element of a within the group. A group G is cyclic if every element of G is a power a^k (k is an integer) of a fixed element $a \in G$. The element a is said to **generate** the group G or to be a generator of G . A cyclic group is always abelian and may be finite or infinite.

The additive group of integers is an infinite cyclic group generated by the element 1. In this case, powers are interpreted additively, so that n is the n th power of 1.

5.2 RINGS

A ring R , sometimes denoted by $\{R, +, \times\}$, is a set of elements with two binary operations, called *addition* and *multiplication*,³ such that for all a, b, c in R the following axioms are obeyed.

(A1–A5) R is an abelian group with respect to addition; that is, R satisfies axioms A1 through A5. For the case of an additive group, we denote the identity element as 0 and the inverse of a as $-a$.

(M1) Closure under multiplication: If a and b belong to R , then ab is also in R .

(M2) Associativity of multiplication: $a(bc) = (ab)c$ for all a, b, c in R .

(M3) Distributive laws: $a(b + c) = ab + ac$ for all a, b, c in R .
 $(a + b)c = ac + bc$ for all a, b, c in R .

In essence, a ring is a set of elements in which we can do addition, subtraction [$a - b = a + (-b)$], and multiplication without leaving the set.

With respect to addition and multiplication, the set of all n -square matrices over the real numbers is a ring.

A ring is said to be **commutative** if it satisfies the following additional condition:

(M4) Commutativity of multiplication: $ab = ba$ for all a, b in R .

³Generally, we do not use the multiplication symbol, \times , but denote multiplication by the concatenation of two elements. Thus, $a \times b$ is written as ab .

Let S be the set of even integers (positive, negative, and 0) under the usual operations of addition and multiplication. S is a commutative ring. The set of all n -square matrices defined in the preceding example is not a commutative ring.

The set Z_n of integers $\{0, 1, \dots, n-1\}$, together with the arithmetic operations modulo n , is a commutative ring (Table 4.3).

Next, we define an integral domain, which is a commutative ring that obeys the following axioms.

(M5) Multiplicative identity: There is an element 1 in R such that $a1 = 1a = a$ for all a in R .

(M6) No zero divisors: If a, b in R and $ab = 0$, then either $a = 0$ or $b = 0$.

Let S be the set of integers (positive, negative, and 0) under the usual operations of addition and multiplication. S is an integral domain.

5.3 FIELDS

A **field** F , sometimes denoted by $\{F, +, \times\}$, is a set of elements with two binary operations, called *addition* and *multiplication*, such that for all a, b, c in F the following axioms are obeyed.

(A1–M6) F is an integral domain; that is, F satisfies axioms A1 through A5 and M1 through M6.

(M7) Multiplicative inverse: For each a in F , except 0, there is an element a^{-1} in F such that $aa^{-1} = (a^{-1})a = 1$.

In essence, a field is a set of elements in which we can do addition, subtraction, multiplication, and division without leaving the set. Division is defined with the following rule: $a/b = a(b^{-1})$.

Familiar examples of fields are the rational numbers, the real numbers, and the complex numbers. Note that the set of all integers is not a field, because not every element of the set has a multiplicative inverse; in fact, only the elements 1 and -1 have multiplicative inverses in the integers.

In gaining insight into fields, the following alternate characterization may be useful. A **field** F , denoted by $\{F, +, \times\}$, is a set of elements with two binary operations, called *addition* and *multiplication*, such that the following conditions hold:

1. F forms an abelian group with respect to addition.
2. The nonzero elements of F form an abelian group with respect to multiplication.

- The distributive law holds. That is, for all a, b, c in F ,

$$a(b + c) = ab + ac.$$

$$(a + b)c = ac + bc.$$

- Figure 5.2 summarizes the axioms that define groups, rings, and fields.

5.4 FINITE FIELDS OF THE FORM $\text{GF}(p)$

In Section 5.3, we defined a field as a set that obeys all of the axioms of Figure 5.2 and gave some examples of infinite fields. Infinite fields are not of particular interest in the context of cryptography. However, in addition to infinite fields, there are two types of finite fields, as illustrated in Figure 5.3. Finite fields play a crucial role in many cryptographic algorithms.

It can be shown that the order of a finite field (number of elements in the field) must be a power of a prime p^n , where n is a positive integer. The finite field of order p^n is generally written $\text{GF}(p^n)$; GF stands for Galois field, in honor of the mathematician Galois who first studied finite fields. Two special cases are of interest for our purposes. For $n = 1$, we have the finite field $\text{GF}(p)$; this finite field has a different structure than that for finite fields with $n > 1$ and is studied in this section. For finite fields of the form $\text{GF}(p^n)$, $\text{GF}(2^n)$ fields are of particular cryptographic interest, and these are covered in Section 5.6.

Finite Fields of Order p

For a given prime, p , we define the finite field of order p , $\text{GF}(p)$, as the set Z_p of integers $\{0, 1, \dots, p - 1\}$ together with the arithmetic operations modulo p . Note therefore that we are using ordinary modular arithmetic to define the operations over these fields.

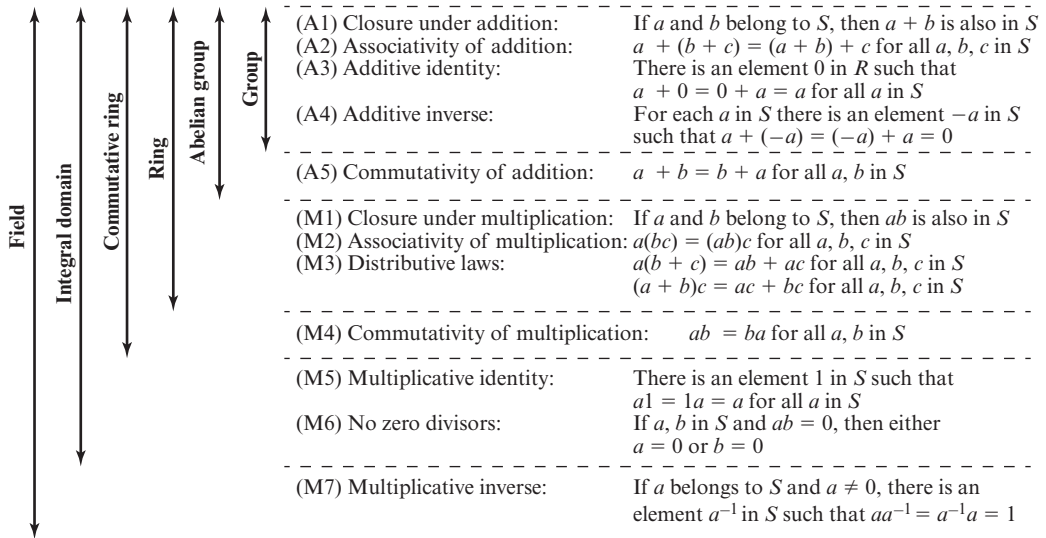

Figure 5.2 Properties of Groups, Rings, and Fields

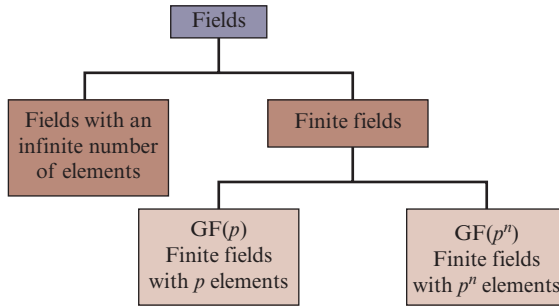

Figure 5.3 Types of Fields

Recall that we showed in Section 5.2 that the set Z_n of integers $\{0, 1, \dots, n - 1\}$, together with the arithmetic operations modulo n , is a commutative ring (Figure 5.2). We further observed that any integer in Z_n has a multiplicative inverse if and only if that integer is relatively prime to n [see discussion of Equation (2.5)].⁴ If n is prime, then all of the nonzero integers in Z_n are relatively prime to n , and therefore there exists a multiplicative inverse for all of the nonzero integers in Z_n . Thus, for Z_p we can add the following properties to those listed in Table 5.2:

Multiplicative inverse (w^{-1})	For each $w \in Z_p, w \neq 0$, there exists a $z \in Z_p$ such that $w \times z \equiv 1 \pmod{p}$
-------------------------------------	--

Because w is relatively prime to p , if we multiply all the elements of Z_p by w , the resulting residues are all of the elements of Z_p permuted. Thus, exactly one of the residues has the value 1. Therefore, there is some integer in Z_p that, when multiplied by w , yields the residue 1. That integer is the multiplicative inverse of w , designated w^{-1} . Therefore, Z_p is in fact a finite field. Furthermore, Equation (2.5) is consistent with the existence of a multiplicative inverse and can be rewritten without the condition that a is relatively prime to n . So, for a and b in Z_p , with $a \neq 0$:

$$\text{if } (a \times b) \equiv (a \times c) \pmod{p} \text{ then } b \equiv c \pmod{p} \tag{5.1}$$

Multiplying both sides of Equation (5.1) by the multiplicative inverse of a , we have

$$\begin{aligned} ((a^{-1}) \times a \times b) &\equiv ((a^{-1}) \times a \times c) \pmod{p} \\ b &\equiv c \pmod{p} \end{aligned}$$

The simplest finite field is GF(2). Its arithmetic operations are easily summarized:										
+	0	1		×	0	1		w	-w	w ⁻¹
0	0	1		0	0	0		0	0	-
1	1	0		1	0	1		1	1	1
Addition			Multiplication				Inverses			
In this case, addition is equivalent to the exclusive-OR (XOR) operation, and multiplication is equivalent to the logical AND operation.										

⁴As stated in the discussion of Equation (2.5), two integers are **relatively prime** if their only common positive integer factor is 1.

The right-hand side of Table 5.1 shows arithmetic operations in $GF(7)$. This is a field of order 7 using modular arithmetic modulo 7. As can be seen, it satisfies all of the properties required of a field (Figure 5.2). Compare with the left-hand side of Table 5.1, which reproduces Table 2.2. In the latter case, we see that the set Z_8 , using modular arithmetic modulo 8, is not a field. Later in this chapter, we show how to define addition and multiplication operations on Z_8 in such a way as to form a finite field.

Finding the Multiplicative Inverse in $GF(p)$

It is easy to find the multiplicative inverse of an element in $GF(p)$ for small values of p . You simply construct a multiplication table, such as shown in Table 5.1e, and the desired result can be read directly. However, for large values of p , this approach is not practical.

If a and b are relatively prime, then b has a multiplicative inverse modulo a . That is, if $\gcd(a, b) = 1$, then b has a multiplicative inverse modulo a . Thus, for positive integer $b < a$, there exists a $b^{-1} < a$ such that $bb^{-1} \equiv 1 \pmod{a}$. If a is a prime number and $0 < b < a$, then clearly a and b are relatively prime and have a greatest common divisor of 1. We now show that we can easily compute b^{-1} using the extended Euclidean algorithm.

We repeat here Equation (2.7), which we showed can be solved with the extended Euclidean algorithm:

$$ax + by = d = \gcd(a, b)$$

Now, if $\gcd(a, b) = 1$, then we have $ax + by = 1$. Using the basic equalities of **modular arithmetic**, defined in Section 2.3, we can say

$$\begin{aligned} [(ax \bmod a) + (by \bmod a)] \bmod a &= 1 \bmod a \\ 0 + (by \bmod a) &= 1 \end{aligned}$$

But if $by \bmod a = 1$, then $y = b^{-1}$. Thus, applying the extended Euclidean algorithm to Equation (2.7) yields the value of the multiplicative inverse of b if $\gcd(a, b) = 1$.

Consider the example that was shown in Table 2.4. Here we have $a = 1759$, which is a prime number, and $b = 550$. The solution of the equation $1759x + 550y = d$ yields a value of $y = 355$. Thus, $b^{-1} = 355$. To verify, we calculate $550 \times 355 \bmod 1759 = 195250 \bmod 1759 = 1$.

More generally, the extended Euclidean algorithm can be used to find a multiplicative inverse in Z_n for any n . If we apply the extended Euclidean algorithm to the equation $nx + by = d$, and the algorithm yields $d = 1$, then $y = b^{-1}$ in Z_n .

Table 5.1 Arithmetic Modulo 8 and Modulo 7

+	0	1	2	3	4	5	6	7
0	0	1	2	3	4	5	6	7
1	1	2	3	4	5	6	7	0
2	2	3	4	5	6	7	0	1
3	3	4	5	6	7	0	1	2
4	4	5	6	7	0	1	2	3
5	5	6	7	0	1	2	3	4
6	6	7	0	1	2	3	4	5
7	7	0	1	2	3	4	5	6

(a) Addition modulo 8

+	0	1	2	3	4	5	6
0	0	1	2	3	4	5	6
1	1	2	3	4	5	6	0
2	2	3	4	5	6	0	1
3	3	4	5	6	0	1	2
4	4	5	6	0	1	2	3
5	5	6	0	1	2	3	4
6	6	0	1	2	3	4	5

(d) Addition modulo 7

×	0	1	2	3	4	5	6	7
0	0	0	0	0	0	0	0	0
1	0	1	2	3	4	5	6	7
2	0	2	4	6	0	2	4	6
3	0	3	6	1	4	7	2	5
4	0	4	0	4	0	4	0	4
5	0	5	2	7	4	1	6	3
6	0	6	4	2	0	6	4	2
7	0	7	6	5	4	3	2	1

(b) Multiplication modulo 8

×	0	1	2	3	4	5	6
0	0	0	0	0	0	0	0
1	0	1	2	3	4	5	6
2	0	2	4	6	1	3	5
3	0	3	6	2	5	1	4
4	0	4	1	5	2	6	3
5	0	5	3	1	6	4	2
6	0	6	5	4	3	2	1

(e) Multiplication modulo 7

w	0	1	2	3	4	5	6	7
$-w$	0	7	6	5	4	3	2	1
w^{-1}	—	1	—	3	—	5	—	7

(c) Additive and multiplicative inverses modulo 8

w	0	1	2	3	4	5	6
$-w$	0	6	5	4	3	2	1
w^{-1}	—	1	4	5	2	3	6

(f) Additive and multiplicative inverses modulo 7

Summary

In this section, we have shown how to construct a finite field of order p , where p is prime. Specifically, we defined $\text{GF}(p)$ with the following properties.

1. $\text{GF}(p)$ consists of p elements.
2. The binary operations $+$ and \times are defined over the set. The operations of addition, subtraction, multiplication, and division can be performed without leaving the set. Each element of the set other than 0 has a multiplicative inverse, and division is performed by multiplication by the multiplicative inverse.

We have shown that the elements of $\text{GF}(p)$ are the integers $\{0, 1, \dots, p - 1\}$ and that the arithmetic operations are addition and multiplication mod p .

5.5 POLYNOMIAL ARITHMETIC

Before continuing our discussion of finite fields, we need to introduce the interesting subject of polynomial arithmetic. We are concerned with polynomials in a single variable x , and we can distinguish three classes of polynomial arithmetic (Figure 5.4).

- Ordinary polynomial arithmetic, using the basic rules of algebra.
- Polynomial arithmetic in which the arithmetic on the coefficients is performed modulo p ; that is, the coefficients are in $\text{GF}(p)$.
- Polynomial arithmetic in which the coefficients are in $\text{GF}(p)$, and the polynomials are defined modulo a polynomial $m(x)$ whose highest power is some integer n .

This section examines the first two classes, and the next section covers the last class.

Ordinary Polynomial Arithmetic

A polynomial of degree n (integer $n \geq 0$) is an expression of the form

$$f(x) = a_n x^n + a_{n-1} x^{n-1} + \cdots + a_1 x + a_0 = \sum_{i=0}^n a_i x^i$$

where the a_i are elements of some designated set of numbers S , called the coefficient set, and $a_n \neq 0$. We say that such polynomials are defined over the coefficient set S .

A zero-degree polynomial is called a constant polynomial and is simply an element of the set of coefficients. An n th-degree polynomial is said to be a monic polynomial if $a_n = 1$.

In the context of abstract algebra, we are usually not interested in evaluating a polynomial for a particular value of x [e.g., $f(7)$]. To emphasize this point, the variable x is sometimes referred to as the **indeterminate**.

Polynomial arithmetic includes the operations of addition, subtraction, multiplication, and division. These operations are defined in a natural way as though the

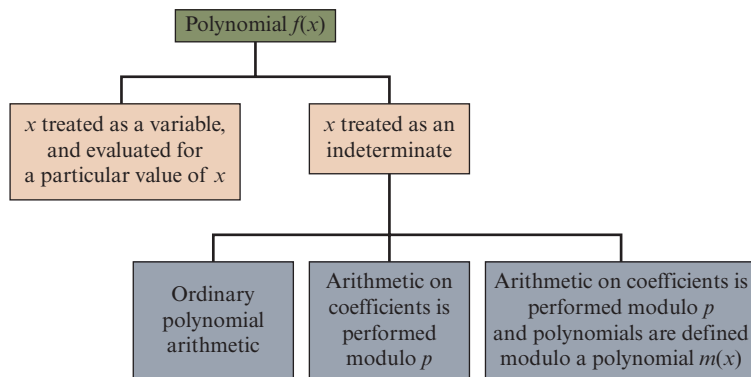

Figure 5.4 Treatment of Polynomials

variable x was an element of S . Division is similarly defined, but requires that S be a field. Examples of fields include the real numbers, rational numbers, and \mathbb{Z}_p for p prime. Note that the set of all integers is not a field and does not support polynomial division.

Addition and subtraction are performed by adding or subtracting corresponding coefficients. Thus, if

$$f(x) = \sum_{i=0}^n a_i x^i, \quad g(x) = \sum_{i=0}^m b_i x^i, \quad n \geq m$$

then addition is defined as

$$f(x) + g(x) = \sum_{i=0}^m (a_i + b_i) x^i + \sum_{i=m+1}^n a_i x^i$$

and multiplication is defined as

$$f(x) \times g(x) = \sum_{i=0}^{n+m} c_i x^i$$

where

$$c_k = a_0 b_k + a_1 b_{k-1} + \cdots + a_{k-1} b_1 + a_k b_0$$

In the last formula, we treat a_i as zero for $i > n$ and b_i as zero for $i > m$. Note that the degree of the product is equal to the sum of the degrees of the two polynomials.

As an example, let $f(x) = x^3 + x^2 + 2$ and $g(x) = x^2 - x + 1$, where S is the set of integers. Then

$$f(x) + g(x) = x^3 + 2x^2 - x + 3$$

$$f(x) - g(x) = x^3 + x + 1$$

$$f(x) \times g(x) = x^5 + 3x^2 - 2x + 2$$

Figures 5.5a through 5.5c show the manual calculations. We comment on division subsequently.

Polynomial Arithmetic with Coefficients in \mathbb{Z}_p

Let us now consider polynomials in which the coefficients are elements of some field F ; we refer to this as a polynomial over the field F . In this case, it is easy to show that the set of such polynomials is a ring, referred to as a polynomial ring. That is, if we consider each distinct polynomial to be an element of the set, then that set is a ring.⁵

When polynomial arithmetic is performed on polynomials over a field, then division is possible. Note that this does not mean that *exact division* is possible. Let

⁵In fact, the set of polynomials whose coefficients are elements of a commutative ring forms a polynomial ring, but that is of no interest in the present context.

$$\begin{array}{r} x^3 + x^2 + 2 \\ + (x^2 - x + 1) \\ \hline x^3 + 2x^2 - x + 3 \end{array}$$

(a) Addition

$$\begin{array}{r} x^3 + x^2 + 2 \\ - (x^2 - x + 1) \\ \hline x^3 + x + 1 \end{array}$$

(b) Subtraction

$$\begin{array}{r} x^3 + x^2 + 2 \\ \times (x^2 - x + 1) \\ \hline x^3 + x^2 + 2 \\ -x^4 - x^3 - 2x \\ \hline x^5 + x^4 + 2x^2 \\ \hline x^5 + 3x^2 - 2x + 2 \end{array}$$

(c) Multiplication

$$\begin{array}{r} x^2 - x + 1 \overline{) x^3 + x^2 + 2} \\ \underline{x^3 + x^2 + x} \\ 2x^2 - x + 2 \\ \underline{2x^2 - 2x + 2} \\ x \end{array}$$

(d) Division

Figure 5.5 Examples of Polynomial Arithmetic

us clarify this distinction. Within a field, given two elements a and b , the quotient a/b is also an element of the field. However, given a ring R that is not a field, in general, division will result in both a quotient and a remainder; this is not exact division.

Consider the division $5/3$ within a set S . If S is the set of rational numbers, which is a field, then the result is simply expressed as $5/3$ and is an element of S . Now suppose that S is the field \mathbb{Z}_7 . In this case, we calculate (using Table 5.1f)

$$5/3 = (5 \times 3^{-1}) \bmod 7 = (5 \times 5) \bmod 7 = 4$$

which is an exact solution. Finally, suppose that S is the set of integers, which is a ring but not a field. Then $5/3$ produces a quotient of 1 and a remainder of 2:

$$\begin{aligned} 5/3 &= 1 + 2/3 \\ 5 &= 1 \times 3 + 2 \end{aligned}$$

Thus, division is not exact over the set of integers.

Now, if we attempt to perform polynomial division over a coefficient set that is not a field, we find that division is not always defined.

If the coefficient set is the integers, then $(5x^2)/(3x)$ does not have a solution, because it would require a coefficient with a value of $5/3$, which is not in the coefficient set. Suppose that we perform the same polynomial division over \mathbb{Z}_7 . Then we have $(5x^2)/(3x) = 4x$, which is a valid polynomial over \mathbb{Z}_7 .

However, as we demonstrate presently, even if the coefficient set is a field, polynomial division is not necessarily exact. In general, division will produce a quotient and a remainder. We can restate the division algorithm of Equation (2.1) for polynomials over a field as follows. Given polynomials $f(x)$ of degree n and $g(x)$

of degree (m) , $(n \geq m)$, if we divide $f(x)$ by $g(x)$, we get a quotient $q(x)$ and a remainder $r(x)$ that obey the relationship

$$f(x) = q(x)g(x) + r(x) \tag{5.2}$$

with polynomial degrees:

- Degree $f(x) = n$
- Degree $g(x) = m$
- Degree $q(x) = n - m$
- $0 \leq \text{Degree } r(x) \leq m - 1$

With the understanding that remainders are allowed, we can say that polynomial division is possible if the coefficient set is a field. One common technique used for polynomial division is polynomial long division, similar to long division for integers. Examples of this are shown subsequently.

In an analogy to integer arithmetic, we can write $f(x) \bmod g(x)$ for the remainder $r(x)$ in Equation (5.2). That is, $r(x) = f(x) \bmod g(x)$. If there is no remainder [i.e., $r(x) = 0$], then we can say $g(x)$ **divides** $f(x)$, written as $g(x) | f(x)$. Equivalently, we can say that $g(x)$ is a **factor** of $f(x)$ or $g(x)$ is a **divisor** of $f(x)$.

For the preceding example [$f(x) = x^3 + x^2 + 2$ and $g(x) = x^2 - x + 1$], $f(x)/g(x)$ produces a quotient of $q(x) = x + 2$ and a remainder $r(x) = x$, as shown in Figure 5.5d. This is easily verified by noting that

$$q(x)g(x) + r(x) = (x + 2)(x^2 - x + 1) + x = (x^3 + x^2 - x + 2) + x = x^3 + x^2 + 2 = f(x)$$

For our purposes, polynomials over GF(2) are of most interest. Recall from Section 5.4 that in GF(2), addition is equivalent to the XOR operation, and multiplication is equivalent to the logical AND operation. Further, addition and subtraction are equivalent mod 2:

$$\begin{aligned} 1 + 1 &= 1 - 1 = 0 \\ 1 + 0 &= 1 - 0 = 1 \\ 0 + 1 &= 0 - 1 = 1 \end{aligned}$$

Figure 5.6 shows an example of polynomial arithmetic over GF(2). For $f(x) = (x^7 + x^5 + x^4 + x^3 + x + 1)$ and $g(x) = (x^3 + x + 1)$, the figure shows $f(x) + g(x)$; $f(x) - g(x)$; $f(x) \times g(x)$; and $f(x)/g(x)$. Note that $g(x) | f(x)$.

A polynomial $f(x)$ over a field F is called irreducible if and only if $f(x)$ cannot be expressed as a product of two polynomials, both over F , and both of degree greater than 0 and lower than that of $f(x)$. By analogy to integers, an irreducible polynomial is also called a prime polynomial.:

The polynomial⁶ $f(x) = x^4 + 1$ over GF(2) is reducible, because

$$x^4 + 1 = (x + 1)(x^3 + x^2 + x + 1).$$

⁶In the remainder of this chapter, unless otherwise noted, all examples are of polynomials over GF(2).

Consider the polynomial $f(x) = x^3 + x + 1$. It is clear by inspection that x is not a factor of $f(x)$. We easily show that $x + 1$ is not a factor of $f(x)$:

$$\begin{array}{r} x^2 + x \\ x + 1 \overline{) x^3 + x^2 + x + 1} \\ \underline{x^3 + x^2} \\ x^2 + x \\ \underline{x^2 + x} \\ 1 \end{array}$$

Thus, $f(x)$ has no factors of degree 1. But it is clear by inspection that if $f(x)$ is reducible, it must have one factor of degree 2 and one factor of degree 1. Therefore, $f(x)$ is irreducible.

$$\begin{array}{r} x^7 + x^5 + x^4 + x^3 + x + 1 \\ + (x^3 + x + 1) \\ \hline x^7 + x^5 + x^4 \end{array}$$

(a) Addition

$$\begin{array}{r} x^7 + x^5 + x^4 + x^3 + x + 1 \\ - (x^3 + x + 1) \\ \hline x^7 + x^5 + x^4 \end{array}$$

(b) Subtraction

$$\begin{array}{r} x^7 + x^5 + x^4 + x^3 + x + 1 \\ \times (x^3 + x + 1) \\ \hline x^7 + x^5 + x^4 + x^3 + x + 1 \\ x^8 + x^6 + x^5 + x^4 + x^2 + x \\ x^{10} + x^8 + x^7 + x^6 + x^4 + x^3 \\ \hline x^{10} + x^4 + x^2 + 1 \end{array}$$

(c) Multiplication

$$\begin{array}{r} x^4 + 1 \\ x^3 + x + 1 \overline{) x^7 + x^5 + x^4 + x^3 + x + 1} \\ \underline{x^7 + x^5 + x^4} \\ x^3 + x + 1 \\ \underline{x^3 + x + 1} \\ 0 \end{array}$$

(d) Division

Figure 5.6 Examples of Polynomial Arithmetic over GF(2)

Finding the Greatest Common Divisor

We can extend the analogy between polynomial arithmetic over a field and integer arithmetic by defining the **greatest common divisor** as follows. The polynomial $c(x)$ is said to be the greatest common divisor of $a(x)$ and $b(x)$ if the following are true.

1. $c(x)$ divides both $a(x)$ and $b(x)$.
2. Any divisor of $a(x)$ and $b(x)$ is a divisor of $c(x)$.

An equivalent definition is the following: $\gcd[a(x), b(x)]$ is the polynomial of maximum degree that divides both $a(x)$ and $b(x)$.

We can adapt the Euclidean algorithm to compute the greatest common divisor of two polynomials. Recall Equation (2.6), from Chapter 2, which is the basis of the Euclidean algorithm: $\gcd(a, b) = \gcd(b, a \bmod b)$ assuming $a > b$. This equality can be rewritten as the following equation:

$$\gcd[a(x), b(x)] = \gcd[b(x), a(x) \bmod b(x)] \tag{5.3}$$

The equation assumes that the degree of $a(x)$ is greater than the degree of $b(x)$. Equation (5.3) can be used repetitively to determine the greatest common divisor. Compare the following scheme to the definition of the Euclidean algorithm for integers.

Euclidean Algorithm for Polynomials	
Calculate	Which satisfies
$r_1(x) = a(x) \bmod b(x)$	$a(x) = q_1(x)b(x) + r_1(x)$
$r_2(x) = b(x) \bmod r_1(x)$	$b(x) = q_2(x)r_1(x) + r_2(x)$
$r_3(x) = r_1(x) \bmod r_2(x)$	$r_1(x) = q_3(x)r_2(x) + r_3(x)$
•	•
•	•
•	•
$r_n(x) = r_{n-2}(x) \bmod r_{n-1}(x)$	$r_{n-2}(x) = q_n(x)r_{n-1}(x) + r_n(x)$
$r_{n+1}(x) = r_{n-1}(x) \bmod r_n(x) = 0$	$r_{n-1}(x) = q_{n+1}(x)r_n(x) + 0$ $d(x) = \gcd(a(x), b(x)) = r_n(x)$

At each iteration, we have $d(x) = \gcd(r_{i+1}(x), r_i(x))$ until finally $d(x) = \gcd(r_n(x), 0) = r_n(x)$. Thus, we can find the greatest common divisor of two polynomials by repetitive application of the division algorithm. This is the Euclidean algorithm for polynomials.

Find $\gcd[a(x), b(x)]$ for $a(x) = x^6 + x^5 + x^4 + x^3 + x^2 + x + 1$ and $b(x) = x^4 + x^2 + x + 1$. First, we divide $a(x)$ by $b(x)$:

$$\begin{array}{r}
 x^2 + x \\
 x^4 + x^2 + x + 1 \overline{) x^6 + x^5 + x^4 + x^3 + x^2 + x + 1} \\
 \underline{x^6 + x^4 + x^3 + x^2} \\
 x^5 + x + 1 \\
 \underline{x^5 + x^3 + x^2 + x} \\
 x^3 + x^2 + 1
 \end{array}$$

This yields $r_1(x) = x^3 + x^2 + 1$ and $q_1(x) = x^2 + x$.
Then, we divide $b(x)$ by $r_1(x)$.

$$\begin{array}{r}
 x^3 + x^2 + 1 \overline{) x^4 + x^3 + x^2 + x + 1} \\
 \underline{x^4 + x^3} \\
 x^3 + x^2 + 1 \\
 \underline{x^3 + x^2} \\
 1
 \end{array}$$

This yields $r_2(x) = 0$ and $q_2(x) = x + 1$.

Therefore, $\text{gcd}[a(x), b(x)] = r_1(x) = x^3 + x^2 + 1$.

Summary

We began this section with a discussion of arithmetic with ordinary polynomials. In ordinary polynomial arithmetic, the variable is not evaluated; that is, we do not plug a value in for the variable of the polynomials. Instead, arithmetic operations are performed on polynomials (addition, subtraction, multiplication, division) using the ordinary rules of algebra. Polynomial division is not allowed unless the coefficients are elements of a field.

Next, we discussed polynomial arithmetic in which the coefficients are elements of $\text{GF}(p)$. In this case, polynomial addition, subtraction, multiplication, and division are allowed. However, division is not exact; that is, in general division results in a quotient and a remainder.

Finally, we showed that the Euclidean algorithm can be extended to find the greatest common divisor of two polynomials whose coefficients are elements of a field.

All of the material in this section provides a foundation for the following section, in which polynomials are used to define finite fields of order p^n .

5.6 FINITE FIELDS OF THE FORM $\text{GF}(2^n)$

Earlier in this chapter, we mentioned that the order of a finite field must be of the form p^n , where p is a prime and n is a positive integer. In Section 5.4, we looked at the special case of finite fields with order p . We found that, using modular arithmetic in \mathbb{Z}_p , all of the axioms for a field (Figure 5.2) are satisfied. For polynomials over p^n , with $n > 1$, operations modulo p^n do not produce a field. In this section, we show what structure satisfies the axioms for a field in a set with p^n elements and concentrate on $\text{GF}(2^n)$.

Motivation

Virtually all encryption algorithms, both symmetric and asymmetric, involve arithmetic operations on integers. If one of the operations that is used in the algorithm is division, then we need to work in arithmetic defined over a field. For convenience

and for implementation efficiency, we would also like to work with integers that fit exactly into a given number of bits with no wasted bit patterns. That is, we wish to work with integers in the range 0 through $2^n - 1$, which fit into an n -bit word.

Suppose we wish to define a conventional encryption algorithm that operates on data 8 bits at a time, and we wish to perform division. With 8 bits, we can represent integers in the range 0 through 255. However, 256 is not a prime number, so that if arithmetic is performed in Z_{256} (arithmetic modulo 256), this set of integers will not be a field. The closest prime number less than 256 is 251. Thus, the set Z_{251} , using arithmetic modulo 251, is a field. However, in this case the 8-bit patterns representing the integers 251 through 255 would not be used, resulting in inefficient use of storage.

As the preceding example points out, if all arithmetic operations are to be used and we wish to represent a full range of integers in n bits, then arithmetic modulo 2^n will not work. Equivalently, the set of integers modulo 2^n for $n > 1$, is not a field. Furthermore, even if the encryption algorithm uses only addition and multiplication, but not division, the use of the set Z_{2^n} is questionable, as the following example illustrates.

Suppose we wish to use 3-bit blocks in our encryption algorithm and use only the operations of addition and multiplication. Then arithmetic modulo 8 is well defined, as shown in Table 5.1. However, note that in the multiplication table, the nonzero integers do not appear an equal number of times. For example, there are only four occurrences of 3, but twelve occurrences of 4. On the other hand, as was mentioned, there are finite fields of the form $GF(2^n)$, so there is in particular a finite field of order $2^3 = 8$. Arithmetic for this field is shown in Table 5.2. In this case, the number of occurrences of the nonzero integers is uniform for multiplication. To summarize,

Integer	1	2	3	4	5	6	7
Occurrences in Z_8	4	8	4	12	4	8	4
Occurrences in $GF(2^3)$	7	7	7	7	7	7	7

For the moment, let us set aside the question of how the matrices of Table 5.2 were constructed and instead make some observations.

1. The addition and multiplication tables are symmetric about the main diagonal, in conformance to the commutative property of addition and multiplication. This property is also exhibited in Table 5.1, which uses mod 8 arithmetic.
2. All the nonzero elements defined by Table 5.2 have a multiplicative inverse, unlike the case with Table 5.1.
3. The scheme defined by Table 5.2 satisfies all the requirements for a finite field. Thus, we can refer to this scheme as $GF(2^3)$.
4. For convenience, we show the 3-bit assignment used for each of the elements of $GF(2^3)$.

Intuitively, it would seem that an algorithm that maps the integers unevenly onto themselves might be cryptographically weaker than one that provides a uniform mapping. That is, a cryptanalytic technique might be able to exploit the fact that some integers occur more frequently and some less frequently in the ciphertext. Thus, the finite fields of the form GF(2ⁿ) are attractive for cryptographic algorithms.

To summarize, we are looking for a set consisting of 2ⁿ elements, together with a definition of addition and multiplication over the set that define a field. We can assign a unique integer in the range 0 through 2ⁿ - 1 to each element of the set. Keep in mind that we will not use modular arithmetic, as we have seen that this does not result in a field. Instead, we will show how polynomial arithmetic provides a means for constructing the desired field.

Modular Polynomial Arithmetic

Consider the set S of all polynomials of degree $n - 1$ or less over the field Z_p . Thus, each polynomial has the form

$$f(x) = a_{n-1}x^{n-1} + a_{n-2}x^{n-2} + \cdots + a_1x + a_0 = \sum_{i=0}^{n-1} a_i x^i$$

Table 5.2 Arithmetic in GF(2³)

		000	001	010	011	100	101	110	111
	+	0	1	2	3	4	5	6	7
000	0	0	1	2	3	4	5	6	7
001	1	1	0	3	2	5	4	7	6
010	2	2	3	0	1	6	7	4	5
011	3	3	2	1	0	7	6	5	4
100	4	4	5	6	7	0	1	2	3
101	5	5	4	7	6	1	0	3	2
110	6	6	7	4	5	2	3	0	1
111	7	7	6	5	4	3	2	1	0

(a) Addition

		000	001	010	011	100	101	110	111
	×	0	1	2	3	4	5	6	7
000	0	0	0	0	0	0	0	0	0
001	1	0	1	2	3	4	5	6	7
010	2	0	2	4	6	3	1	7	5
011	3	0	3	6	5	7	4	1	2
100	4	0	4	3	7	6	2	5	1
101	5	0	5	1	4	2	7	3	6
110	6	0	6	7	1	5	3	2	4
111	7	0	7	5	2	1	6	4	3

(b) Multiplication

	w	-w	w ⁻¹
0	0	0	-
1	1	1	1
2	2	2	5
3	3	3	6
4	4	4	7
5	5	5	2
6	6	6	3
7	7	7	4

(c) Additive and multiplicative inverses

where each a_i takes on a value in the set $\{0, 1, \dots, p - 1\}$. There are a total of p^n different polynomials in S .

For $p = 3$ and $n = 2$, the $3^2 = 9$ polynomials in the set are
 $0, 1, 2, x, x + 1, x + 2, 2x, 2x + 1, 2x + 2$
 For $p = 2$ and $n = 3$, the $2^3 = 8$ polynomials in the set are
 $0, 1, x, x + 1, x^2, x^2 + 1, x^2 + x, x^2 + x + 1$

With the appropriate definition of arithmetic operations, each such set S is a finite field. The definition consists of the following elements.

1. Arithmetic follows the ordinary rules of polynomial arithmetic using the basic rules of algebra, with the following two refinements.
2. Arithmetic on the coefficients is performed modulo p . That is, we use the rules of arithmetic for the finite field \mathbb{Z}_p .
3. If multiplication results in a polynomial of degree greater than $n - 1$, then the polynomial is reduced modulo some irreducible polynomial $m(x)$ of degree n . That is, we divide by $m(x)$ and keep the remainder. For a polynomial $f(x)$, the remainder is expressed as $r(x) = f(x) \bmod m(x)$.

The Advanced Encryption Standard (AES) uses arithmetic in the finite field $\text{GF}(2^8)$, with the irreducible polynomial $m(x) = x^8 + x^4 + x^3 + x + 1$. Consider the two polynomials $f(x) = x^6 + x^4 + x^2 + x + 1$ and $g(x) = x^7 + x + 1$. Then

$$f(x) + g(x) = x^6 + x^4 + x^2 + x + 1 + x^7 + x + 1$$

$$= x^7 + x^6 + x^4 + x^2$$

$$f(x) \times g(x) = x^{13} + x^{11} + x^9 + x^8 + x^7$$

$$+ x^7 + x^5 + x^3 + x^2 + x$$

$$+ x^6 + x^4 + x^2 + x + 1$$

$$= x^{13} + x^{11} + x^9 + x^8 + x^6 + x^5 + x^4 + x^3 + 1$$

$$x^8 + x^4 + x^3 + x + 1 \overline{) x^{13} + x^{11} + x^9 + x^8 + x^6 + x^5 + x^4 + x^3 + 1}$$

$$\underline{x^{13} \phantom{+ x^{11} + x^9 + x^8} + x^6 + x^5}$$

$$ x^{11} + x^4 + x^3$$

$$\underline{ x^{11} + x^7 + x^6} + x^4 + x^3$$

$$ \phantom{x^{11} + x^9 + x^8} x^7 + x^6 + 1$$

Therefore, $f(x) \times g(x) \bmod m(x) = x^7 + x^6 + 1$.

As with ordinary modular arithmetic, we have the notion of a set of residues in **modular polynomial arithmetic**. The set of residues modulo $m(x)$, an n th-degree polynomial, consists of p^n elements. Each of these elements is represented by one of the p^n polynomials of degree $m < n$.

The residue class $[x + 1], (\text{mod } m(x))$, consists of all polynomials $a(x)$ such that $a(x) \equiv (x + 1) (\text{mod } m(x))$. Equivalently, the residue class $[x + 1]$ consists of all polynomials $a(x)$ that satisfy the equality $a(x) \text{ mod } m(x) = x + 1$.

It can be shown that the set of all polynomials modulo an irreducible n th-degree polynomial $m(x)$ satisfies the axioms in Figure 5.2, and thus forms a finite field. Furthermore, all finite fields of a given order are isomorphic; that is, any two finite-field structures of a given order have the same structure, but the representation or labels of the elements may be different.

To construct the finite field $\text{GF}(2^3)$, we need to choose an irreducible polynomial of degree 3. There are only two such polynomials: $(x^3 + x^2 + 1)$ and $(x^3 + x + 1)$. Using the latter, Table 5.3 shows the addition and multiplication tables for $\text{GF}(2^3)$. Note that this set of tables has the identical structure to those of Table 5.2. Thus, we have succeeded in finding a way to define a field of order 2^3 . We can now read additions and multiplications from the table easily. For example, consider binary $100 + 010 = 110$. This is equivalent to $x^2 + x$. Also consider $100 \times 010 = 011$, which is equivalent to $x^2 \times x = x^3$ and reduces to $x + 1$. That is, $x^3 \text{ mod } (x^3 + x + 1) = x + 1$, which is equivalent to 011.

Finding the Multiplicative Inverse

Just as the Euclidean algorithm can be adapted to find the greatest common divisor of two polynomials, the extended Euclidean algorithm can be adapted to find the multiplicative inverse of a polynomial. Specifically, the algorithm will find the multiplicative inverse of $b(x)$ modulo $a(x)$ if the degree of $b(x)$ is less than the degree of $a(x)$ and $\text{gcd}[a(x), b(x)] = 1$. If $a(x)$ is an irreducible polynomial, then it has no factor other than itself or 1, so that $\text{gcd}[a(x), b(x)] = 1$. The algorithm can be characterized in the same way as we did for the extended Euclidean algorithm for integers. Given polynomials $a(x)$ and $b(x)$ with the degree of $a(x)$ greater than the degree of $b(x)$, we wish to solve the following equation for the values $v(x)$, $w(x)$, and $d(x)$, where $d(x) = \text{gcd}[a(x), b(x)]$:

$$a(x)v(x) + b(x)w(x) = d(x)$$

If $d(x) = 1$, then $w(x)$ is the multiplicative inverse of $b(x)$ modulo $a(x)$. The calculations are as follows.

Table 5.3 Polynomial Arithmetic Modulo $(x^3 + x + 1)$

	000	001	010	011	100	101	110	111
+								
000	0	1	x	x + 1	x ²	x ² + 1	x ² + x	x ² + x + 1
001	1	0	x + 1	x	x ² + 1	x ²	x ² + x + 1	x ² + x
010	x	x + 1	0	1	x ² + x	x ² + x + 1	x ²	x ² + 1
011	x + 1	x	1	0	x ² + x + 1	x ² + x	x ² + 1	x ²
100	x ²	x ² + 1	x ² + x	x ² + x + 1	0	1	x	x + 1
101	x ² + 1	x ²	x ² + x + 1	x ² + x	1	0	x + 1	x
110	x ² + x	x ² + x + 1	x ²	x ² + 1	x	x + 1	0	1
111	x ² + x + 1	x ² + x	x ² + 1	x ²	x + 1	x	1	0

(a) Addition

	000	001	010	011	100	101	110	111
×								
000	0	0	0	0	0	0	0	0
001	0	1	x	x + 1	x ²	x ² + 1	x ² + x	x ² + x + 1
010	0	x	x ²	x ² + x	x + 1	1	x ² + x + 1	x ² + 1
011	0	x + 1	x ² + x	x ² + 1	x ² + x + 1	x ²	1	x
100	0	x ²	x + 1	x ² + x + 1	x ² + x	x	x ² + 1	1
101	0	x ² + 1	1	x ²	x	x ² + x + 1	x + 1	x ² + x
110	0	x ² + x	x ² + x + 1	1	x ² + 1	x + 1	x	x ²
111	0	x ² + x + 1	x ² + 1	x	1	x ² + 1	x ²	x + 1

(b) Multiplication

Extended Euclidean Algorithm for Polynomials			
Calculate	Which satisfies	Calculate	Which satisfies
$r_{-1}(x) = a(x)$		$v_{-1}(x) = 1; w_{-1}(x) = 0$	$a(x) = a(x)v_{-1}(x) + bw_{-1}(x)$
$r_0(x) = b(x)$		$v_0(x) = 0; w_0(x) = 1$	$b(x) = a(x)v_0(x) + b(x)w_0(x)$
$r_1(x) = a(x) \bmod b(x)$ $q_1(x) = \text{quotient of } a(x)/b(x)$	$a(x) = q_1(x)b(x) + r_1(x)$	$v_1(x) = v_{-1}(x) - q_1(x)v_0(x) = 1$ $w_1(x) = w_{-1}(x) - q_1(x)w_0(x) = -q_1(x)$	$r_1(x) = a(x)v_1(x) + b(x)w_1(x)$
$r_2(x) = b(x) \bmod r_1(x)$ $q_2(x) = \text{quotient of } b(x)/r_1(x)$	$b(x) = q_2(x)r_1(x) + r_2(x)$	$v_2(x) = v_0(x) - q_2(x)v_1(x)$ $w_2(x) = w_0(x) - q_2(x)w_1(x)$	$r_2(x) = a(x)v_2(x) + b(x)w_2(x)$
$r_3(x) = r_1(x) \bmod r_2(x)$ $q_3(x) = \text{quotient of } r_1(x)/r_2(x)$	$r_1(x) = q_3(x)r_2(x) + r_3(x)$	$v_3(x) = v_1(x) - q_3(x)v_2(x)$ $w_3(x) = w_1(x) - q_3(x)w_2(x)$	$r_3(x) = a(x)v_3(x) + b(x)w_3(x)$
• • •	• • •	• • ⋮	• • •
$r_n(x) = r_{n-2}(x) \bmod r_{n-1}(x)$ $q_n(x) = \text{quotient of } r_{n-2}(x)/r_{n-1}(x)$	$r_{n-2}(x) = q_n(x)r_{n-1}(x) + r_n(x)$	$v_n(x) = v_{n-2}(x) - q_n(x)v_{n-1}(x)$ $w_n(x) = w_{n-2}(x) - q_n(x)w_{n-1}(x)$	$r_n(x) = a(x)v_n(x) + b(x)w_n(x)$
$r_{n+1}(x) = r_{n-1}(x) \bmod r_n(x) = 0$ $q_{n+1}(x) = \text{quotient of } r_{n-1}(x)/r_n(x)$	$r_{n-1}(x) = q_{n+1}(x)r_n(x) + 0$		$d(x) = \gcd(a(x), b(x)) = r_n(x)$ $v(x) = v_n(x); w(x) = w_n(x)$

Table 5.4 shows the calculation of the multiplicative inverse of $(x^7 + x + 1) \bmod (x^8 + x^4 + x^3 + x + 1)$. The result is that $(x^7 + x + 1)^{-1} = (x^7)$. That is, $(x^7 + x + 1)(x^7) \equiv 1 \pmod{(x^8 + x^4 + x^3 + x + 1)}$.

Computational Considerations

A polynomial $f(x)$ in GF(2ⁿ)

$$f(x) = a_{n-1}x^{n-1} + a_{n-2}x^{n-2} + \cdots + a_1x + a_0 = \sum_{i=0}^{n-1} a_i x^i$$

can be uniquely represented by the sequence of its n binary coefficients $(a_{n-1}, a_{n-2}, \dots, a_0)$. Thus, every polynomial in GF(2ⁿ) can be represented by an n -bit number.

Table 5.4 Extended Euclid $[(x^8 + x^4 + x^3 + x + 1), (x^7 + x + 1)]$

Initialization	$a(x) = x^8 + x^4 + x^3 + x + 1; v_{-1}(x) = 1; w_{-1}(x) = 0$ $b(x) = x^7 + x + 1; v_0(x) = 0; w_0(x) = 1$
Iteration 1	$q_1(x) = x; r_1(x) = x^4 + x^3 + x^2 + 1$ $v_1(x) = 1; w_1(x) = x$
Iteration 2	$q_2(x) = x^3 + x^2 + 1; r_2(x) = x$ $v_2(x) = x^3 + x^2 + 1; w_2(x) = x^4 + x^3 + x + 1$
Iteration 3	$q_3(x) = x^3 + x^2 + x; r_3(x) = 1$ $v_3(x) = x^6 + x^2 + x + 1; w_3(x) = x^7$
Iteration 4	$q_4(x) = x; r_4(x) = 0$ $v_4(x) = x^7 + x + 1; w_4(x) = x^8 + x^4 + x^3 + x + 1$
Result	$d(x) = r_3(x) = \gcd(a(x), b(x)) = 1$ $w(x) = w_3(x) = (x^7 + x + 1)^{-1} \bmod (x^8 + x^4 + x^3 + x + 1) = x^7$

Tables 5.2 and 5.3 show the addition and multiplication tables for $\text{GF}(2^3)$ modulo $m(x) = (x^3 + x + 1)$. Table 5.2 uses the binary representation, and Table 5.3 uses the polynomial representation.

ADDITION We have seen that addition of polynomials is performed by adding corresponding coefficients, and, in the case of polynomials over \mathbb{Z}_2 , addition is just the XOR operation. So, addition of two polynomials in $\text{GF}(2^n)$ corresponds to a bitwise XOR operation.

Consider the two polynomials in $\text{GF}(2^8)$ from our earlier example:

$$f(x) = x^6 + x^4 + x^2 + x + 1 \text{ and } g(x) = x^7 + x + 1.$$

$(x^6 + x^4 + x^2 + x + 1) + (x^7 + x + 1)$	$= x^7 + x^6 + x^4 + x^2$	(polynomial notation)
$(01010111) \oplus (10000011)$	$= (11010100)$	(binary notation)
$\{57\} \oplus \{83\}$	$= \{D4\}$	(hexadecimal notation) ⁷

MULTIPLICATION There is no simple XOR operation that will accomplish multiplication in $\text{GF}(2^n)$. However, a reasonably straightforward, easily implemented technique is available. We will discuss the technique with reference to $\text{GF}(2^8)$ using $m(x) = x^8 + x^4 + x^3 + x + 1$, which is the finite field used in AES. The technique readily generalizes to $\text{GF}(2^n)$.

The technique is based on the observation that

$$x^8 \bmod m(x) = [m(x) - x^8] = (x^4 + x^3 + x + 1) \tag{5.4}$$

⁷A basic refresher on number systems (decimal, binary, hexadecimal) can be found at the Computer Science Student Resource Site at WilliamStallings.com/StudentSupport.html. Here each of two groups of 4 bits in a byte is denoted by a single hexadecimal character, and the two characters are enclosed in brackets.

A moment's thought should convince you that Equation (5.4) is true; if you are not sure, divide it out. In general, in GF(2ⁿ) with an *n*th-degree polynomial *p*(*x*), we have $x^n \bmod p(x) = [p(x) - x^n]$.

Now, consider a polynomial in GF(2⁸), which has the form $f(x) = b_7x^7 + b_6x^6 + b_5x^5 + b_4x^4 + b_3x^3 + b_2x^2 + b_1x + b_0$. If we multiply by *x*, we have

$$x \times f(x) = (b_7x^8 + b_6x^7 + b_5x^6 + b_4x^5 + b_3x^4 + b_2x^3 + b_1x^2 + b_0x) \bmod m(x) \quad (5.5)$$

If $b_7 = 0$ in Equation (5.5), then the result is a polynomial of degree less than 8, which is already in reduced form, and no further computation is necessary. If $b_7 = 1$, then reduction modulo *m*(*x*) is achieved using Equation (5.4):

$$x \times f(x) = (b_6x^7 + b_5x^6 + b_4x^5 + b_3x^4 + b_2x^3 + b_1x^2 + b_0x) + (x^4 + x^3 + x + 1)$$

It follows that multiplication by *x* (i.e., 00000010) can be implemented as a 1-bit left shift followed by a conditional bitwise XOR with (00011011), which represents $(x^4 + x^3 + x + 1)$. To summarize,

$$x \times f(x) = \begin{cases} (b_6b_5b_4b_3b_2b_1b_0) & \text{if } b_7 = 0 \\ (b_6b_5b_4b_3b_2b_1b_0) \oplus (00011011) & \text{if } b_7 = 1 \end{cases} \quad (5.6)$$

Multiplication by a higher power of *x* can be achieved by repeated application of Equation (5.6). By adding intermediate results, multiplication by any constant in GF(2⁸) can be achieved.

In an earlier example, we showed that for $f(x) = x^6 + x^4 + x^2 + x + 1$, $g(x) = x^7 + x + 1$, and $m(x) = x^8 + x^4 + x^3 + x + 1$, we have $f(x) \times g(x) \bmod m(x) = x^7 + x^6 + 1$. Redoing this in binary arithmetic, we need to compute $(01010111) \times (10000011)$. First, we determine the results of multiplication by powers of *x*:

$$\begin{aligned} (01010111) \times (00000010) &= (10101110) \\ (01010111) \times (00000100) &= (01011100) \oplus (00011011) = (01000111) \\ (01010111) \times (00001000) &= (10001110) \\ (01010111) \times (00010000) &= (00011100) \oplus (00011011) = (00000111) \\ (01010111) \times (00100000) &= (00001110) \\ (01010111) \times (01000000) &= (00011100) \\ (01010111) \times (10000000) &= (00111000) \end{aligned}$$

So,

$$\begin{aligned} (01010111) \times (10000011) &= (01010111) \times [(00000001) \oplus (00000010) \oplus (10000000)] \\ &= (01010111) \oplus (10101110) \oplus (00111000) = (11000001) \end{aligned}$$

which is equivalent to $x^7 + x^6 + 1$.

Using a Generator

An equivalent technique for defining a finite field of the form $\text{GF}(2^n)$, using a primitive polynomial, is sometimes more convenient. To begin, we need several new definitions. A **generator** g of a finite field F of order q (contains q elements) is an element whose first $q - 1$ powers generate all the nonzero elements of F . That is, the elements of F consist of $0, g^0, g^1, \dots, g^{q-2}$.

Recall from the discussion in Chapter 2 that if a is a primitive root of n , then its powers $a, a^2, \dots, a^{b(n)}$ are distinct (mod n) and are all relatively prime to n . In particular, for a prime number p , if a is a primitive root of p , then a, a^2, \dots, a^{p-1} are distinct (mod p). Consider a field F defined by a polynomial $f(x)$. An element b contained in F is called a **root** of the polynomial if $f(b) = 0$.

A monic polynomial $f(x)$ is a **primitive polynomial** of degree n over a finite field $\text{GF}(p)$ if and only if all of its roots are generators of the nonzero elements of the finite field $\text{GF}(p^n)$. In particular, it can be shown that $f(x)$ satisfies the following equation:

$$x^{p^n-1} \equiv 1 \pmod{f(x)}$$

Moreover, (p^n-1) is the least positive integer for which the preceding equation is true. That is, there is no integer $m < (p^n-1)$ for which $f(x)$ divides $(x^m - 1)$. For example, for $\text{GF}(2^3)$, $f(x) = x^3 + x + 1$ is a primitive polynomial. Thus,

$$x^{2^3-1} = x^7 \equiv 1 \pmod{x^3 + x + 1}$$

which is easily shown.

All primitive polynomials are also irreducible, but the reverse is not true. For an irreducible polynomial that is not a primitive polynomial, we can find a positive integer $m < (p^n-1)$. For example, the irreducible polynomial used to define the $\text{GF}(2^8)$ finite field for AES is $f(x) = x^8 + x^4 + x^3 + x + 1$. In this case, it can be easily calculated that $f(x)$ divides $(x^{51} - 1)$. But, because $51 \leq (2^8 - 1)$, $f(x)$ is not a primitive polynomial. A root of this polynomial can generate only 51 nonzero elements of $\text{GF}(2^8)$.

Let us consider the finite field $\text{GF}(2^3)$, defined over the primitive polynomial $x^3 + x + 1$, discussed previously. Thus, the generator g must satisfy $f(g) = g^3 + g + 1 = 0$. Keep in mind, as discussed previously, that we need not find a numerical solution to this equality. Rather, we deal with polynomial arithmetic in which arithmetic on the coefficients is performed modulo 2. Therefore, the solution to the preceding equality is $g^3 = -g - 1 = g + 1$. We now show that g in fact generates all of the polynomials of degree less than 3. We have the following.

$$\begin{aligned} g^4 &= g(g^3) = g(g + 1) = g^2 + g \\ g^5 &= g(g^4) = g(g^2 + g) = g^3 + g^2 = g^2 + g + 1 \\ g^6 &= g(g^5) = g(g^2 + g + 1) = g^3 + g^2 + g = g^2 + g + g + 1 = g^2 + 1 \\ g^7 &= g(g^6) = g(g^2 + 1) = g^3 + g = g + g + 1 = 1 = g^0 \end{aligned}$$

We see that the powers of g generate all the nonzero polynomials in GF(2³). Also, it should be clear that $g^k = g^{k \bmod 7}$ for any integer k . Table 5.5 shows the power representation, as well as the polynomial and binary representations.

This power representation makes multiplication easy. To multiply in the power notation, add exponents modulo 7. For example, $g^4 \times g^6 = g^{(10 \bmod 7)} = g^3 = g + 1$. The same result is achieved using polynomial arithmetic: We have $g^4 = g^2 + g$ and $g^6 = g^2 + 1$. Then, $(g^2 + g) \times (g^2 + 1) = g^4 + g^3 + g^2 + g$. Next, we need to determine $(g^4 + g^3 + g^2 + g) \bmod (g^3 + g + 1)$ by division:

$$\begin{array}{r} g^3 + g + 1 \overline{)g^4 + g^3 + g^2 + g} \\ \underline{g^4 + + g^2 + g} \\ g^3 + \\ \underline{g^3 + + g + 1} \\ g + 1 \end{array}$$

We get a result of $g + 1$, which agrees with the result obtained using the power representation.

Table 5.6 shows the addition and multiplication tables for GF(2³) using the power representation. Note that this yields the identical results to the polynomial representation (Table 5.3) with some of the rows and columns interchanged.

Table 5.5 Generator for GF(2³) using $x^3 + x + 1$

Power Representation	Polynomial Representation	Binary Representation	Decimal (Hex) Representation
0	0	000	0
$g^0 (= g^7)$	1	001	1
g^1	g	010	2
g^2	g^2	100	4
g^3	$g + 1$	011	3
g^4	$g^2 + g$	110	6
g^5	$g^2 + g + 1$	111	7
g^6	$g^2 + 1$	101	5

In general, for GF(2ⁿ) with primitive polynomial $f(x)$, determine $g^n = f(g) - g^n$. Then calculate all of the powers of g from g^{n+1} through g^{2^n-2} . The elements of the field correspond to the powers of g from g^0 through g^{2^n-2} plus the value 0. For multiplication of two elements in the field, use the equality $g^k = g^{k \bmod (2^n-1)}$ for any integer k .

Table 5.6 GF(2³) Arithmetic Using Generator for the Polynomial (x³ + x + 1)

	000	001	010	100	011	110	111	101
+	0	1	g	g ²	g ³	g ⁴	g ⁵	g ⁶
000	0	1	g	g ²	g + 1	g ² + g	g ² + g + 1	g ² + 1
001	1	0	g + 1	g ² + 1	g	g ² + g + 1	g ² + g	g ²
010	g	g + 1	0	g ² + g	1	g ²	g ² + 1	g ² + g + 1
100	g ²	g ² + 1	g ² + g	0	g ² + g + 1	g	g + 1	1
011	g + 1	g	1	g ² + g + 1	0	g ² + 1	g ²	g ² + g
110	g ² + g	g ² + g + 1	g ²	g	g ² + 1	0	1	g + 1
111	g ² + g + 1	g ² + g	g ² + 1	g + 1	g ²	1	0	g
101	g ² + 1	g ²	g ² + g + 1	1	g ² + g	g + 1	g	0

(a) Addition

	000	001	010	100	011	110	111	101
×	0	1	g	g ²	g ³	g ⁴	g ⁵	g ⁶
000	0	0	0	0	0	0	0	0
001	0	1	g	g ²	g + 1	g ² + g	g ² + g + 1	g ² + 1
010	0	g	g ²	g + 1	g ² + g	g ² + g + 1	g ² + 1	1
100	0	g ²	g + 1	g ² + g	g ² + g + 1	g ² + 1	1	g
011	0	g + 1	g ² + g	g ² + g + 1	g ² + 1	1	g	g ²
110	0	g ² + g	g ² + g + 1	g ² + 1	1	g	g ²	g + 1
111	0	g ² + g + 1	g ² + 1	1	g	g ²	g + 1	g ² + g
101	0	g ² + 1	1	g	g ²	g + 1	g ² + g	g ² + g + 1

(b) Multiplication

Summary

In this section, we have shown how to construct a finite field of order 2^n . Specifically, we defined $\text{GF}(2^n)$ with the following properties.

1. $\text{GF}(2^n)$ consists of 2^n elements.
2. The binary operations $+$ and \times are defined over the set. The operations of addition, subtraction, multiplication, and division can be performed without leaving the set. Each element of the set other than 0 has a multiplicative inverse.

We have shown that the elements of $\text{GF}(2^n)$ can be defined as the set of all polynomials of degree $n - 1$ or less with binary coefficients. Each such polynomial can be represented by a unique n -bit value. Arithmetic is defined as polynomial arithmetic modulo some irreducible polynomial of degree n . We have also seen that an equivalent definition of a finite field $\text{GF}(2^n)$ makes use of a generator and that arithmetic is defined using powers of the generator.

5.7 KEY TERMS, REVIEW QUESTIONS, AND PROBLEMS

Key Terms

commutative divisor field	finite field greatest common divisor identity element	modular arithmetic order relatively prime
---------------------------------	---	---

Review Questions

- 5.1 Briefly define a group.
- 5.2 Briefly define a ring.
- 5.3 Briefly define a field.
- 5.4 Briefly define an irreducible polynomial.

Problems

- 5.1 Consider the group S_7 of all permutations of 7 distinct symbols.
 - a. Let $x = (1, 2, 3)(4, 6)$ and $y = (2, 3, 4, 5, 6)$ in S_7 be two permutations that are written in disjoint cycle notation. Compute $x \cdot y$ and $y \cdot x$.
 - b. Is S_7 abelian?
- 5.2 Does the set of residue classes $(\text{mod}3)$ form a group
 - a. with respect to modular addition?
 - b. with respect to modular multiplication?

- 5.3** Let $S = \{0, a, b, c\}$. The addition and multiplication on the set S is defined in the following tables:

+	0	a	B	C	×	0	a	b	c
0	0	a	B	C	0	0	0	0	0
A	a	0	c	B	a	0	a	b	c
B	b	c	0	A	b	0	a	b	c
C	c	b	a	0	c	0	0	0	0

Is S a noncommutative ring? Justify your answer.

- 5.4** Develop a set of tables similar to Table 5.1 for $\text{GF}(5)$.
- 5.5** Demonstrate that the set of polynomials whose coefficients form a field is a ring.
- 5.6** Let R be the field of real numbers. Let $R[x]$ be the ring of polynomials with coefficients in field R . State whether each of the following statements is true or false.
- $R[x]$ is a commutative ring with unity, with multiplicative identity being the constant polynomial 1.
 - $f \in R[x]$ has a multiplicative inverse if and only if f is a non-zero constant.
 - $R[x]$ is also a field.
- 5.7** For polynomial arithmetic with coefficients in Z_{11} , perform the following calculations.
- $(x^2 + 2x + 9)(x^3 + 11x^2 + x + 7)$
 - $(8x^2 + 3x + 2)(5x^2 + 6)$
- 5.8** Determine which of the following polynomials are reducible over $\text{GF}(2)$.
- $x^2 + 1$
 - $x^2 + x + 1$
 - $x^4 + x + 1$
- 5.9** Determine the gcd of the following pairs of polynomials.
- $(x^3 + 1)$ and $(x^2 + x + 1)$ over $\text{GF}(2)$
 - $(x^3 + x + 1)$ and $(x^2 + 1)$ over $\text{GF}(3)$
 - $(x^3 - 2x + 1)$ and $(x^2 - x - 2)$ over $\text{GF}(5)$
 - $(x^4 + 8x^3 + 7x + 8)$ and $(2x^3 + 9x^2 + 10x + 1)$ over $\text{GF}(11)$
- 5.10** Develop a set of tables similar to Table 5.3 for $\text{GF}(3)$ with $m(x) = x^2 + x + 1$.
- 5.11** Determine the multiplicative inverse of $x^2 + 1$ in $\text{GF}(2^3)$ with $m(x) = x^3 + x - 1$.
- 5.12** Develop a table similar to Table 5.5 for $\text{GF}(2^5)$ with $m(x) = x^5 + x^4 + x^3 + x + 1$.

Programming Problems

- 5.1** Write a simple four-function calculator in $\text{GF}(2^4)$. You may use table lookups for the multiplicative inverses.
- 5.2** Write a simple four-function calculator in $\text{GF}(2^8)$. You should compute the multiplicative inverses on the fly.

CHAPTER 6

ADVANCED ENCRYPTION STANDARD

6.1 Finite Field Arithmetic

6.2 AES Structure

- General Structure
- Detailed Structure

6.3 AES Transformation Functions

- Substitute Bytes Transformation
- ShiftRows Transformation
- MixColumns Transformation
- AddRoundKey Transformation

6.4 AES Key Expansion

- Key Expansion Algorithm
- Rationale

6.5 An AES Example

- Results
- Avalanche Effect

6.6 AES Implementation

- Equivalent Inverse Cipher
- Implementation Aspects

6.7 Key Terms, Review Questions, and Problems

Appendix 6A Polynomials with Coefficients in $GF(2^8)$

LEARNING OBJECTIVES

After studying this chapter, you should be able to:

- ◆ Present an overview of the general structure of Advanced Encryption Standard (AES).
- ◆ Understand the four transformations used in AES.
- ◆ Explain the AES key expansion algorithm.
- ◆ Understand the use of polynomials with coefficients in $GF(2^8)$.

The **Advanced Encryption Standard (AES)** was published by the National Institute of Standards and Technology (NIST) in 2001. AES is a symmetric block cipher that is intended to replace DES as the approved standard for a wide range of applications.

[NECH01], available from NIST, summarizes the evaluation criteria used by NIST to select from among the candidates for AES, plus the rationale for picking Rijndael, which was the winning candidate. This material is useful in understanding not just the AES design but also the criteria by which to judge any symmetric encryption algorithm. The essence of the criteria was to develop an algorithm with a high level of security and good performance on a range of systems.

It is worth making additional comment about the performance of AES. Because of the popularity of AES, a number of efforts have been made to improve performance through both software and hardware optimization. Most notably, in 2008, Intel introduced the Advanced Encryption Standard New Instructions (AES-NI) as a hardware extension to the x86 instruction set to improve the speed of encryption and decryption. The AES-NI instruction enables x86 processors to achieve a performance of 0.64 cycles/byte for an authenticated encryption mode known as AES-GCM (described in Chapter 12).

In 2018, Intel added vectorized instructions, referred to as VAES*, to the existing AES-NI for its high-end processors [INTE17]. These instructions are intended to push the performance of AES software further down, to a new theoretical throughput of 0.16 cycles/byte [DRUC18].

AES has become the most widely used symmetric cipher. Compared to public-key ciphers such as RSA, the structure of AES and most symmetric ciphers is quite complex and cannot be explained as easily as many other cryptographic algorithms. Accordingly, the reader may wish to begin with a simplified version of AES, which is described in Appendix A. This version allows the reader to perform encryption and decryption by hand and gain a good understanding of the working of the algorithm details. Classroom experience indicates that a study of this simplified version enhances understanding of AES. One possible approach is to read the chapter first, then carefully read Appendix A and then re-read the main body of the chapter.

6.1 FINITE FIELD ARITHMETIC

In AES, all operations are performed on 8-bit bytes. In particular, the arithmetic operations of addition, multiplication, and division are performed over the finite field $\text{GF}(2^8)$. Section 5.6 discusses such operations in some detail. For the reader who has not studied Chapter 5, and as a quick review for those who have, this section summarizes the important concepts.

In essence, a **field** is a set in which we can do addition, subtraction, multiplication, and division without leaving the set. Division is defined with the following rule: $a/b = a(b^{-1})$. An example of a **finite field** (one with a finite number of elements) is the set Z_p consisting of all the integers $\{0, 1, \dots, p - 1\}$, where p is a prime number and in which arithmetic is carried out modulo p .

Virtually all encryption algorithms, both conventional and public-key, involve arithmetic operations on integers. If one of the operations used in the algorithm is division, then we need to work in arithmetic defined over a field; this is because division requires that each nonzero element have a multiplicative inverse. For convenience and for implementation efficiency, we would also like to work with integers that fit exactly into a given number of bits, with no wasted bit patterns. That is, we wish to work with integers in the range 0 through $2^n - 1$, which fit into an n -bit word. Unfortunately, the set of such integers, Z_{2^n} , using modular arithmetic, is not a field. For example, the integer 2 has no multiplicative inverse in Z_{2^n} , that is, there is no integer b , such that $2b \bmod 2^n = 1$.

There is a way of defining a finite field containing 2^n elements; such a field is referred to as $\text{GF}(2^n)$. Consider the set, S , of all polynomials of degree $n - 1$ or less with binary coefficients. Thus, each polynomial has the form

$$f(x) = a_{n-1}x^{n-1} + a_{n-2}x^{n-2} + \dots + a_1x + a_0 = \sum_{i=0}^{n-1} a_i x^i$$

where each a_i takes on the value 0 or 1. There are a total of 2^n different polynomials in S . For $n = 3$, the $2^3 = 8$ polynomials in the set are

$$\begin{array}{llll} 0 & x & x^2 & x^2 + x \\ 1 & x + 1 & x^2 + 1 & x^2 + x + 1 \end{array}$$

With the appropriate definition of arithmetic operations, each such set S is a finite field. The definition consists of the following elements.

1. Arithmetic follows the ordinary rules of polynomial arithmetic using the basic rules of algebra with the following two refinements.
2. Arithmetic on the coefficients is performed modulo 2. This is the same as the XOR operation.
3. If multiplication results in a polynomial of degree greater than $n - 1$, then the polynomial is reduced modulo some irreducible polynomial $m(x)$ of degree n . That is, we divide by $m(x)$ and keep the remainder. For a polynomial $f(x)$, the remainder is expressed as $r(x) = f(x) \bmod m(x)$. A polynomial $m(x)$ is called irreducible if and only if $m(x)$ cannot be expressed as a product of two polynomials, both of degree lower than that of $m(x)$.

For example, to construct the finite field $\text{GF}(2^3)$, we need to choose an irreducible polynomial of degree 3. There are only two such polynomials: $(x^3 + x^2 + 1)$ and $(x^3 + x + 1)$. Addition is equivalent to taking the XOR of like terms. Thus, $(x + 1) + x = 1$.

A polynomial in $\text{GF}(2^n)$ can be uniquely represented by its n binary coefficients $(a_{n-1}a_{n-2} \dots a_0)$. Therefore, every polynomial in $\text{GF}(2^n)$ can be represented by an n -bit number. Addition is performed by taking the bitwise XOR of the two n -bit elements. There is no simple XOR operation that will accomplish multiplication in $\text{GF}(2^n)$. However, a reasonably straightforward, easily implemented, technique is available. In essence, it can be shown that multiplication of a number in $\text{GF}(2^n)$ by 2 consists of a left shift followed by a conditional XOR with a constant. Multiplication by larger numbers can be achieved by repeated application of this rule.

For example, AES uses arithmetic in the finite field $\text{GF}(2^8)$ with the irreducible polynomial $m(x) = x^8 + x^4 + x^3 + x + 1$. Consider two elements $A = (a_7a_6 \dots a_1a_0)$ and $B = (b_7b_6 \dots b_1b_0)$. The sum $A + B = (c_7c_6 \dots c_1c_0)$, where $c_i = a_i \oplus b_i$. The multiplication $\{02\} \cdot A$ equals $(a_6 \dots a_1a_00)$ if $a_7 = 0$ and equals $(a_6 \dots a_1a_00) \oplus (00011011)$ if $a_7 = 1$.¹

To summarize, AES operates on 8-bit bytes. Addition of two bytes is defined as the bitwise XOR operation. Multiplication of two bytes is defined as multiplication in the finite field $\text{GF}(2^8)$, with the irreducible polynomial² $m(x) = x^8 + x^4 + x^3 + x + 1$. The developers of Rijndael give as their motivation for selecting this one of the 30 possible irreducible polynomials of degree 8 that it is the first one on the list given in [LIDL94].

6.2 AES STRUCTURE

General Structure

Figure 6.1 shows the overall structure of the AES encryption process. The cipher takes a plaintext block size of 128 bits, or 16 bytes. The key length can be 16, 24, or 32 bytes (128, 192, or 256 bits). The algorithm is referred to as AES-128, AES-192, or AES-256, depending on the key length.

The input to the encryption and decryption algorithms is a single 128-bit block. In FIPS PUB 197, this block is depicted as a 4×4 square matrix of bytes. This block is copied into the **State** array, which is modified at each stage of encryption or decryption. After the final stage, **State** is copied to an output matrix. These operations are depicted in Figure 6.2a. Similarly, the key is depicted as a square matrix of bytes. This key is then expanded into an array of key schedule words. Figure 6.2b shows the expansion for the 128-bit key. Each word is four bytes, and the total key schedule is 44 words for the 128-bit key. Note that the ordering of bytes within a matrix is by column. So, for example, the first four bytes of a 128-bit plaintext input to the encryption cipher occupy the first column of the **in** matrix, the second four

¹In FIPS PUB 197, a hexadecimal number is indicated by enclosing it in curly brackets. We use that convention in this chapter.

²In the remainder of this discussion, references to $\text{GF}(2^8)$ refer to the finite field defined with this polynomial.

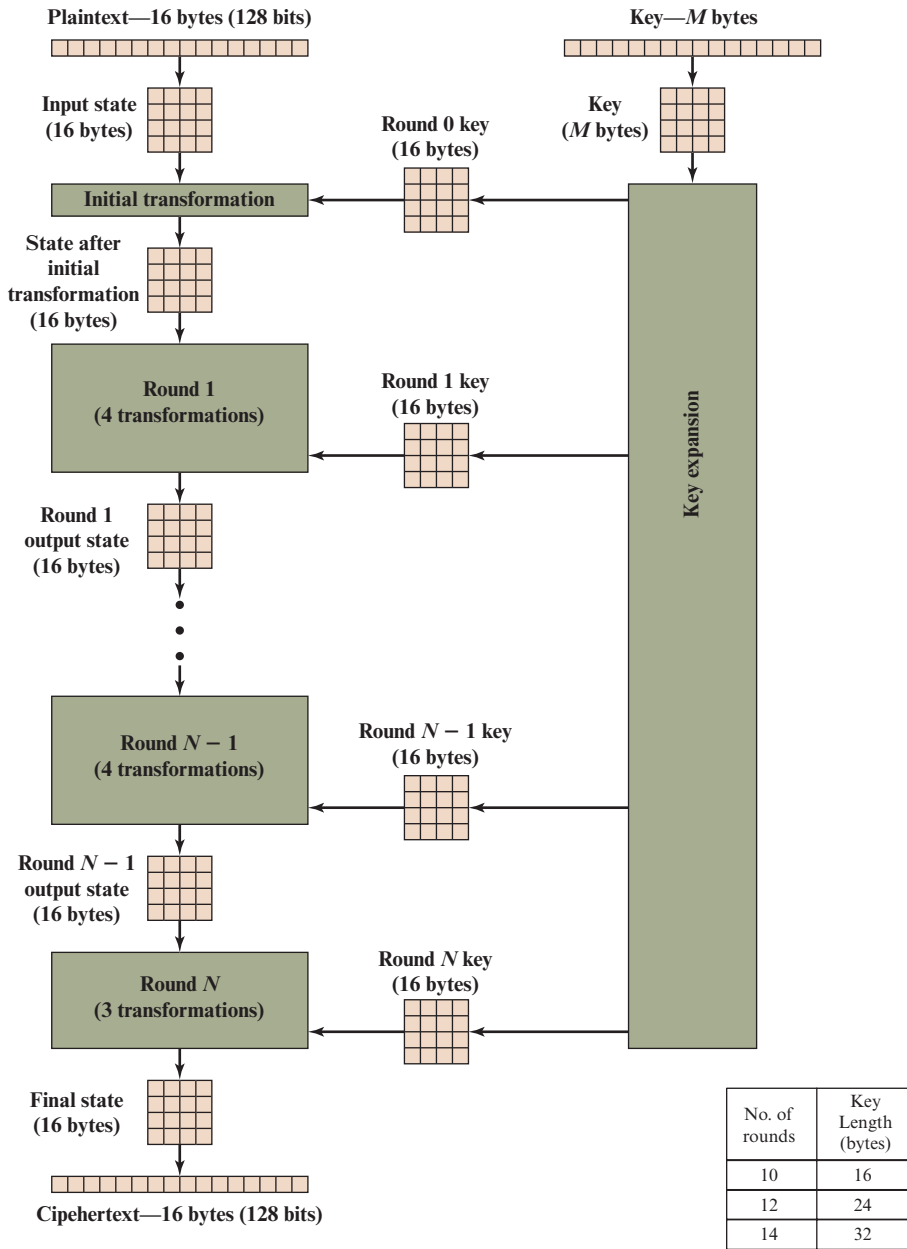
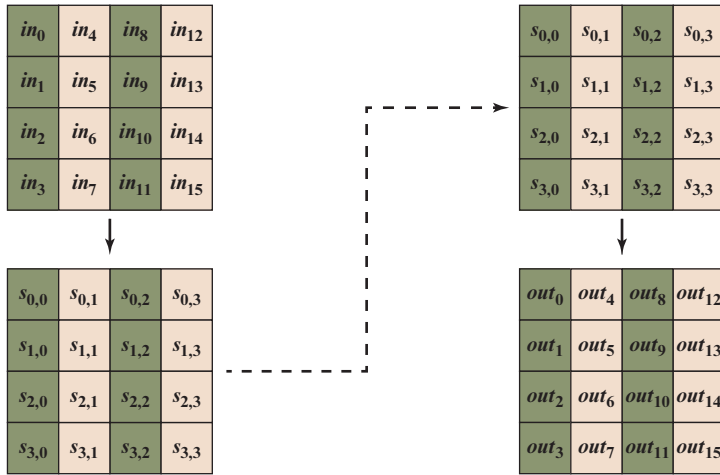

Figure 6.1 AES Encryption Process

bytes occupy the second column, and so on. Similarly, the first four bytes of the expanded key, which form a word, occupy the first column of the \mathbf{w} matrix.

The cipher consists of N rounds, where the number of rounds depends on the key length: 10 rounds for a 16-byte key, 12 rounds for a 24-byte key, and 14 rounds for a 32-byte key (Table 6.1). The first $N - 1$ rounds consist of four distinct



(a) Input, state array, and output

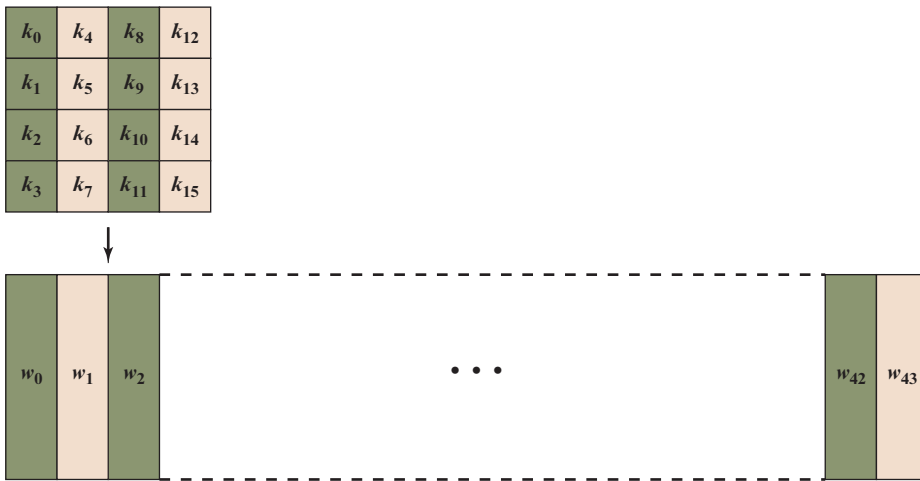

(b) Key and expanded key

Figure 6.2 AES Data Structures

Table 6.1 AES Parameters

Key Size (words/bytes/bits)	4/16/128	6/24/192	8/32/256
Plaintext Block Size (words/bytes/bits)	4/16/128	4/16/128	4/16/128
Number of Rounds	10	12	14
Round Key Size (words/bytes/bits)	4/16/128	4/16/128	4/16/128
Expanded Key Size (words/bytes)	44/176	52/208	60/240

transformation functions: SubBytes, ShiftRows, MixColumns, and AddRoundKey, which are described subsequently. The final round contains only three transformations, and there is an initial single transformation (AddRoundKey) before the first round, which can be considered Round 0. Each transformation takes one or more 4×4 matrices as input and produces a 4×4 matrix as output. Figure 6.1 shows that the output of each round is a 4×4 matrix, with the output of the final round being the ciphertext. Also, the key expansion function generates $N + 1$ round keys, each of which is a distinct 4×4 matrix. Each round key serves as one of the inputs to the AddRoundKey transformation in each round.

Detailed Structure

Figure 6.3 shows the AES cipher in more detail, indicating the sequence of transformations in each round and showing the corresponding decryption function. As was done in Chapter 4, we show encryption proceeding down the page and decryption proceeding up the page.

Before delving into details, we can make several comments about the overall AES structure.

1. One noteworthy feature of this structure is that it is not a Feistel structure. Recall that, in the classic Feistel structure, half of the data block is used to modify the other half of the data block and then the halves are swapped. AES instead processes the entire data block as a single matrix during each round using substitutions and permutation.
2. The key that is provided as input is expanded into an array of forty-four 32-bit words, $\mathbf{w}[i]$. Four distinct words (128 bits) serve as a round key for each round; these are indicated in Figure 6.3.
3. Four different stages are used, one of permutation and three of substitution:
 - **Substitute bytes:** Uses an S-box to perform a byte-by-byte substitution of the block.
 - **ShiftRows:** A simple permutation.
 - **MixColumns:** A substitution that makes use of arithmetic over $\text{GF}(2^8)$.
 - **AddRoundKey:** A simple bitwise XOR of the current block with a portion of the expanded key.
4. The structure is quite simple. For both encryption and decryption, the cipher begins with an AddRoundKey stage, followed by nine rounds that each includes all four stages, followed by a tenth round of three stages. Figure 6.4 depicts the structure of a full encryption round.
5. Only the AddRoundKey stage makes use of the key. For this reason, the cipher begins and ends with an AddRoundKey stage. Any other stage, applied at the beginning or end, is reversible without knowledge of the key and so would add no security.

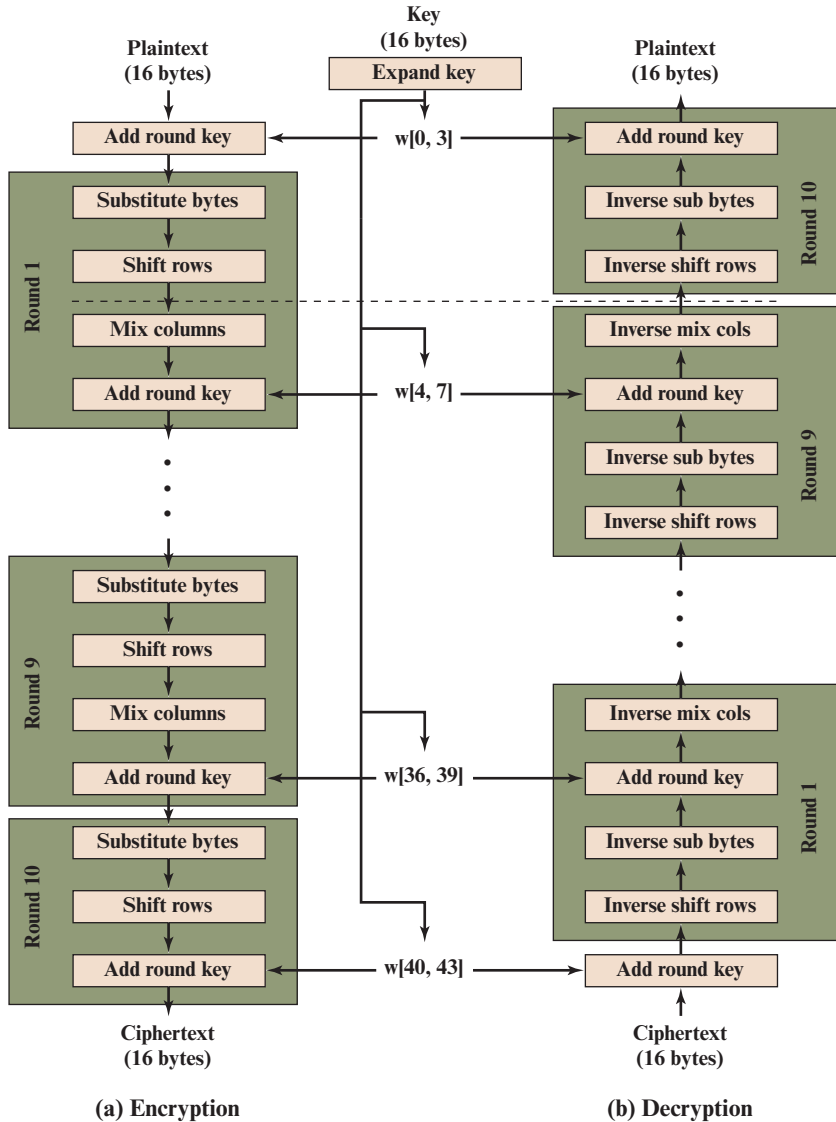

Figure 6.3 AES Encryption and Decryption

- The AddRoundKey stage is, in effect, a form of Vernam cipher and by itself would not be formidable. The other three stages together provide confusion, diffusion, and nonlinearity, but by themselves would provide no security because they do not use the key. We can view the cipher as alternating operations of XOR encryption (AddRoundKey) of a block, followed by scrambling of the block (the other three stages), followed by XOR encryption, and so on. This scheme is both efficient and highly secure.

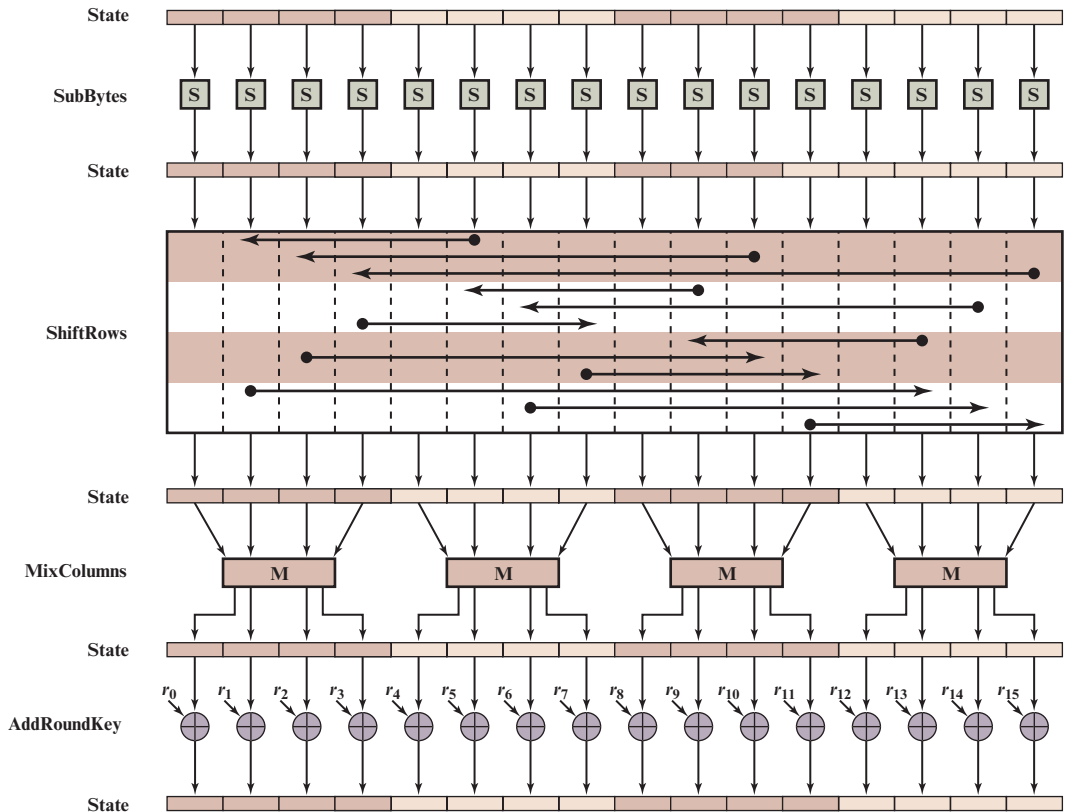

Figure 6.4 AES Encryption Round

7. Each stage is easily reversible. For the Substitute Byte, ShiftRows, and MixColumns stages, an inverse function is used in the decryption algorithm. For the AddRoundKey stage, the inverse is achieved by XORing the same round key to the block, using the result that $A \oplus B \oplus B = A$.
8. As with most block ciphers, the decryption algorithm makes use of the expanded key in reverse order. However, the decryption algorithm is not identical to the encryption algorithm. This is a consequence of the particular structure of AES.
9. Once it is established that all four stages are reversible, it is easy to verify that decryption does recover the plaintext. Figure 6.3 lays out encryption and decryption going in opposite vertical directions. At each horizontal point (e.g., the dashed line in the figure), **State** is the same for both encryption and decryption.
10. The final round of both encryption and decryption consists of only three stages. Again, this is a consequence of the particular structure of AES and is required to make the cipher reversible.

6.3 AES TRANSFORMATION FUNCTIONS

We now turn to a discussion of each of the four transformations used in AES. For each stage, we describe the forward (encryption) algorithm, the inverse (decryption) algorithm, and the rationale for the stage.

Substitute Bytes Transformation

FORWARD AND INVERSE TRANSFORMATIONS The **forward substitute byte transformation**, called SubBytes, is a simple table lookup (Figure 6.5a). AES defines a 16×16 matrix of byte values, called an **S-box** (Table 6.2a), that contains a permutation of all possible 256 8-bit values. Each individual byte of **State** is mapped into a new byte in the following way: The leftmost 4 bits of the byte are used as a row value and the rightmost 4 bits are used as a column value. These row and column values serve as indexes into the S-box to select a unique 8-bit output value.

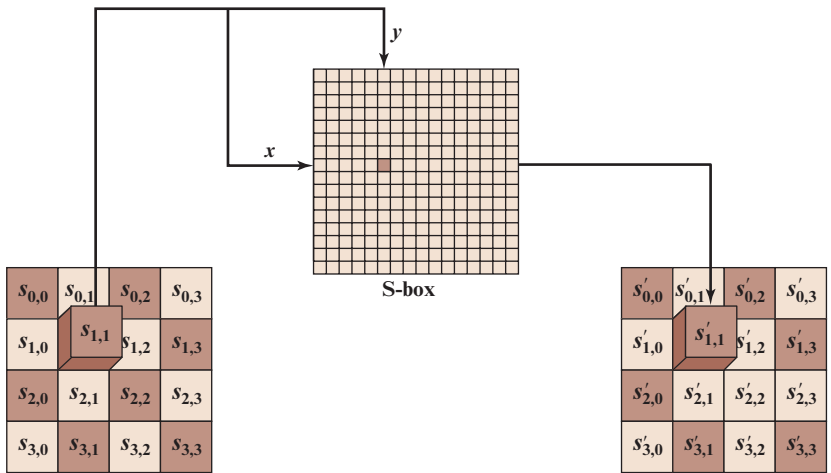

(a) Substitute byte transformation

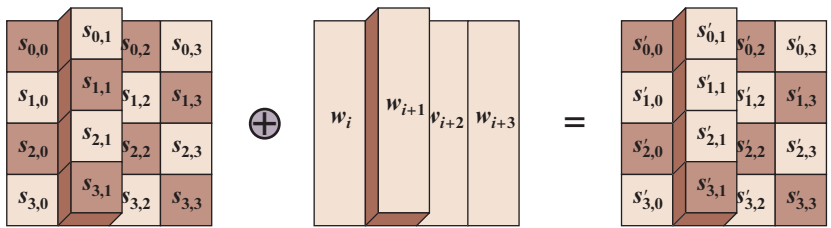

(b) Add round key transformation

Figure 6.5 AES Byte-Level Operations

Table 6.2 AES S-Boxes

		y															
		0	1	2	3	4	5	6	7	8	9	A	B	C	D	E	F
x	0	63	7C	77	7B	F2	6B	6F	C5	30	01	67	2B	FE	D7	AB	76
	1	CA	82	C9	7D	FA	59	47	F0	AD	D4	A2	AF	9C	A4	72	C0
	2	B7	FD	93	26	36	3F	F7	CC	34	A5	E5	F1	71	D8	31	15
	3	04	C7	23	C3	18	96	05	9A	07	12	80	E2	EB	27	B2	75
	4	09	83	2C	1A	1B	6E	5A	A0	52	3B	D6	B3	29	E3	2F	84
	5	53	D1	00	ED	20	FC	B1	5B	6A	CB	BE	39	4A	4C	58	CF
	6	D0	EF	AA	FB	43	4D	33	85	45	F9	02	7F	50	3C	9F	A8
	7	51	A3	40	8F	92	9D	38	F5	BC	B6	DA	21	10	FF	F3	D2
	8	CD	0C	13	EC	5F	97	44	17	C4	A7	7E	3D	64	5D	19	73
	9	60	81	4F	DC	22	2A	90	88	46	EE	B8	14	DE	5E	0B	DB
	A	E0	32	3A	0A	49	06	24	5C	C2	D3	AC	62	91	95	E4	79
	B	E7	C8	37	6D	8D	D5	4E	A9	6C	56	F4	EA	65	7A	AE	08
	C	BA	78	25	2E	1C	A6	B4	C6	E8	DD	74	1F	4B	BD	8B	8A
	D	70	3E	B5	66	48	03	F6	0E	61	35	57	B9	86	C1	1D	9E
	E	E1	F8	98	11	69	D9	8E	94	9B	1E	87	E9	CE	55	28	DF
	F	8C	A1	89	0D	BF	E6	42	68	41	99	2D	0F	B0	54	BB	16

(a) S-box

		y															
		0	1	2	3	4	5	6	7	8	9	A	B	C	D	E	F
x	0	52	09	6A	D5	30	36	A5	38	BF	40	A3	9E	81	F3	D7	FB
	1	7C	E3	39	82	9B	2F	FF	87	34	8E	43	44	C4	DE	E9	CB
	2	54	7B	94	32	A6	C2	23	3D	EE	4C	95	0B	42	FA	C3	4E
	3	08	2E	A1	66	28	D9	24	B2	76	5B	A2	49	6D	8B	D1	25
	4	72	F8	F6	64	86	68	98	16	D4	A4	5C	CC	5D	65	B6	92
	5	6C	70	48	50	FD	ED	B9	DA	5E	15	46	57	A7	8D	9D	84
	6	90	D8	AB	00	8C	BC	D3	0A	F7	E4	58	05	B8	B3	45	06
	7	D0	2C	1E	8F	CA	3F	0F	02	C1	AF	BD	03	01	13	8A	6B
	8	3A	91	11	41	4F	67	DC	EA	97	F2	CF	CE	F0	B4	E6	73
	9	96	AC	74	22	E7	AD	35	85	E2	F9	37	E8	1C	75	DF	6E
	A	47	F1	1A	71	1D	29	C5	89	6F	B7	62	0E	AA	18	BE	1B
	B	FC	56	3E	4B	C6	D2	79	20	9A	DB	C0	FE	78	CD	5A	F4
	C	1F	DD	A8	33	88	07	C7	31	B1	12	10	59	27	80	EC	5F
	D	60	51	7F	A9	19	B5	4A	0D	2D	E5	7A	9F	93	C9	9C	EF
	E	A0	E0	3B	4D	AE	2A	F5	B0	C8	EB	BB	3C	83	53	99	61
	F	17	2B	04	7E	BA	77	D6	26	E1	69	14	63	55	21	0C	7D

(b) Inverse S-box

For example, the hexadecimal value {95} references row 9, column 5 of the S-box, which contains the value {2A}. Accordingly, the value {95} is mapped into the value {2A}.

Here is an example of the SubBytes transformation:

EA	04	65	85
83	45	5D	96
5C	33	98	B0
F0	2D	AD	C5

→

87	F2	4D	97
EC	6E	4C	90
4A	C3	46	E7
8C	D8	95	A6

The S-box is constructed in the following fashion (Figure 6.6a).

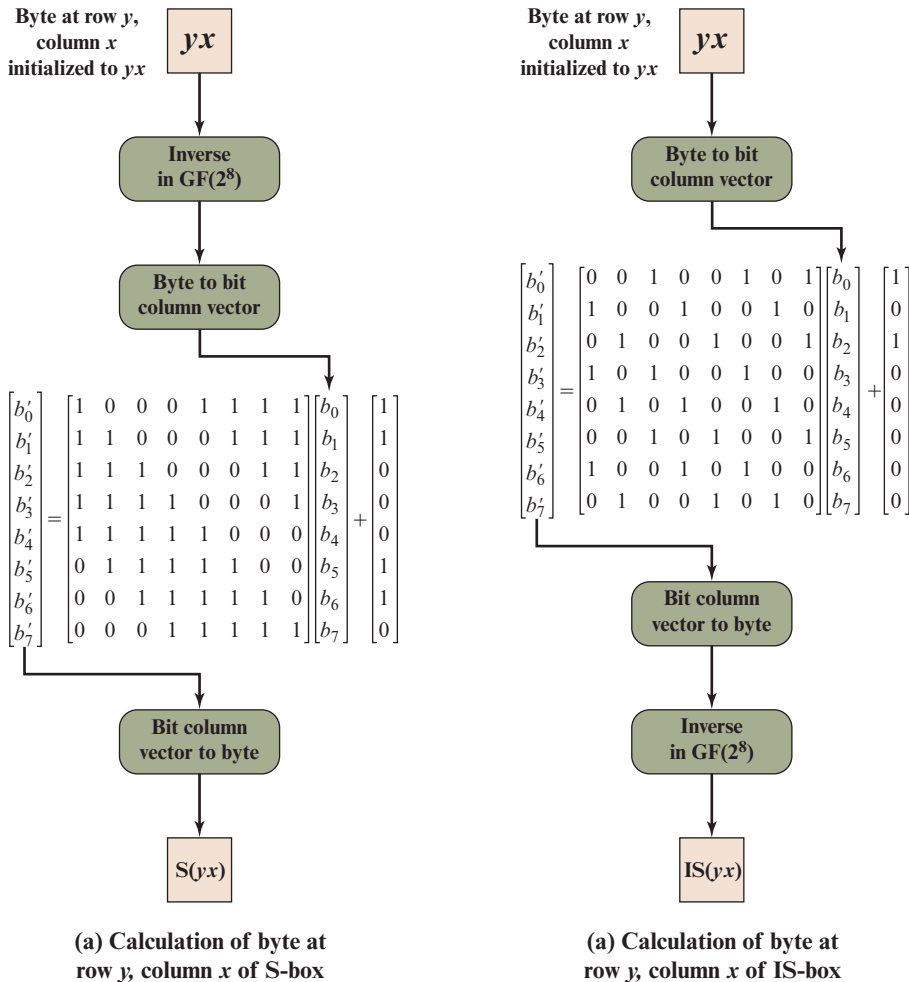

Figure 6.6 Construction of S-Box and IS-Box

1. Initialize the S-box with the byte values in ascending sequence row by row. The first row contains {00}, {01}, {02}, . . . , {0F}; the second row contains {10}, {11}, etc.; and so on. Thus, the value of the byte at row y , column x is $\{yx\}$.
2. Map each byte in the S-box to its multiplicative inverse in the finite field $\text{GF}(2^8)$; the value {00} is mapped to itself.
3. Consider that each byte in the S-box consists of 8 bits labeled $(b_7, b_6, b_5, b_4, b_3, b_2, b_1, b_0)$. Apply the following transformation to each bit of each byte in the S-box:

$$b'_i = b_i \oplus b_{(i+4) \bmod 8} \oplus b_{(i+5) \bmod 8} \oplus b_{(i+6) \bmod 8} \oplus b_{(i+7) \bmod 8} \oplus c_i \quad (6.1)$$

where c_i is the i th bit of byte c with the value {63}; that is, $(c_7c_6c_5c_4c_3c_2c_1c_0) = (01100011)$. The prime ($'$) indicates that the variable is to be updated by the value on the right. The AES standard depicts this transformation in matrix form as follows.

$$\begin{bmatrix} b'_0 \\ b'_1 \\ b'_2 \\ b'_3 \\ b'_4 \\ b'_5 \\ b'_6 \\ b'_7 \end{bmatrix} = \begin{bmatrix} 1 & 0 & 0 & 0 & 1 & 1 & 1 & 1 \\ 1 & 1 & 0 & 0 & 0 & 1 & 1 & 1 \\ 1 & 1 & 1 & 0 & 0 & 0 & 1 & 1 \\ 1 & 1 & 1 & 1 & 0 & 0 & 0 & 1 \\ 1 & 1 & 1 & 1 & 1 & 0 & 0 & 0 \\ 0 & 1 & 1 & 1 & 1 & 1 & 0 & 0 \\ 0 & 0 & 1 & 1 & 1 & 1 & 1 & 0 \\ 0 & 0 & 0 & 1 & 1 & 1 & 1 & 1 \end{bmatrix} \begin{bmatrix} b_0 \\ b_1 \\ b_2 \\ b_3 \\ b_4 \\ b_5 \\ b_6 \\ b_7 \end{bmatrix} + \begin{bmatrix} 1 \\ 1 \\ 0 \\ 0 \\ 0 \\ 1 \\ 1 \\ 0 \end{bmatrix} \quad (6.2)$$

Equation (6.2) has to be interpreted carefully. In ordinary matrix multiplication,³ each element in the product matrix is the sum of products of the elements of one row and one column. In this case, each element in the product matrix is the bitwise XOR of products of elements of one row and one column. Furthermore, the final addition shown in Equation (6.2) is a bitwise XOR. Recall from Section 5.6 that the bitwise XOR is addition in $\text{GF}(2^8)$.

As an example, consider the input value {95}. The multiplicative inverse in $\text{GF}(2^8)$ is $\{95\}^{-1} = \{8A\}$, which is 10001010 in binary. Using Equation (6.2),

$$\begin{bmatrix} 1 & 0 & 0 & 0 & 1 & 1 & 1 & 1 \\ 1 & 1 & 0 & 0 & 0 & 1 & 1 & 1 \\ 1 & 1 & 1 & 0 & 0 & 0 & 1 & 1 \\ 1 & 1 & 1 & 1 & 0 & 0 & 0 & 1 \\ 1 & 1 & 1 & 1 & 1 & 0 & 0 & 0 \\ 0 & 1 & 1 & 1 & 1 & 1 & 0 & 0 \\ 0 & 0 & 1 & 1 & 1 & 1 & 1 & 0 \\ 0 & 0 & 0 & 1 & 1 & 1 & 1 & 1 \end{bmatrix} \begin{bmatrix} 0 \\ 1 \\ 0 \\ 1 \\ 0 \\ 0 \\ 0 \\ 1 \end{bmatrix} \oplus \begin{bmatrix} 1 \\ 1 \\ 0 \\ 0 \\ 0 \\ 1 \\ 1 \\ 0 \end{bmatrix} = \begin{bmatrix} 1 \\ 0 \\ 0 \\ 1 \\ 0 \\ 0 \\ 1 \\ 0 \end{bmatrix} \oplus \begin{bmatrix} 1 \\ 1 \\ 0 \\ 0 \\ 0 \\ 1 \\ 1 \\ 0 \end{bmatrix} = \begin{bmatrix} 0 \\ 1 \\ 0 \\ 1 \\ 0 \\ 1 \\ 0 \\ 0 \end{bmatrix}$$

³For a brief review of the rules of matrix and vector multiplication, refer to Appendix B.

The result is {2A}, which should appear in row {09} column {05} of the S-box. This is verified by checking Table 6.2a.

The **inverse substitute byte transformation**, called InvSubBytes, makes use of the inverse S-box shown in Table 6.2b. Note, for example, that the input {2A} produces the output {95}, and the input {95} to the S-box produces {2A}. The inverse S-box is constructed (Figure 6.6b) by applying the inverse of the transformation in Equation (6.1) followed by taking the multiplicative inverse in GF(2⁸). The inverse transformation is

$$b'_i = b_{(i+2) \bmod 8} \oplus b_{(i+5) \bmod 8} \oplus b_{(i+7) \bmod 8} \oplus d_i$$

where byte $d = \{05\}$, or 00000101. We can depict this transformation as follows.

$$\begin{bmatrix} b'_0 \\ b'_1 \\ b'_2 \\ b'_3 \\ b'_4 \\ b'_5 \\ b'_6 \\ b'_7 \end{bmatrix} = \begin{bmatrix} 0 & 0 & 1 & 0 & 0 & 1 & 0 & 1 \\ 1 & 0 & 0 & 1 & 0 & 0 & 1 & 0 \\ 0 & 1 & 0 & 0 & 1 & 0 & 0 & 1 \\ 1 & 0 & 1 & 0 & 0 & 1 & 0 & 0 \\ 0 & 1 & 0 & 1 & 0 & 0 & 1 & 0 \\ 0 & 0 & 1 & 0 & 1 & 0 & 0 & 1 \\ 1 & 0 & 0 & 1 & 0 & 1 & 0 & 0 \\ 0 & 1 & 0 & 0 & 1 & 0 & 1 & 0 \end{bmatrix} \begin{bmatrix} b_0 \\ b_1 \\ b_2 \\ b_3 \\ b_4 \\ b_5 \\ b_6 \\ b_7 \end{bmatrix} + \begin{bmatrix} 1 \\ 0 \\ 1 \\ 0 \\ 0 \\ 0 \\ 0 \\ 0 \end{bmatrix}$$

To see that InvSubBytes is the inverse of SubBytes, label the matrices in SubBytes and InvSubBytes as \mathbf{X} and \mathbf{Y} , respectively, and the vector versions of constants \mathbf{c} and \mathbf{d} as \mathbf{C} and \mathbf{D} , respectively. For some 8-bit vector \mathbf{B} , Equation (6.2) becomes $\mathbf{B}' = \mathbf{X}\mathbf{B} \oplus \mathbf{C}$. We need to show that $\mathbf{Y}(\mathbf{X}\mathbf{B} \oplus \mathbf{C}) \oplus \mathbf{D} = \mathbf{B}$. To multiply out, we must show $\mathbf{Y}\mathbf{X}\mathbf{B} \oplus \mathbf{Y}\mathbf{C} \oplus \mathbf{D} = \mathbf{B}$. This becomes

$$\begin{bmatrix} 0 & 0 & 1 & 0 & 0 & 1 & 0 & 1 \\ 1 & 0 & 0 & 1 & 0 & 0 & 1 & 0 \\ 0 & 1 & 0 & 0 & 1 & 0 & 0 & 1 \\ 1 & 0 & 1 & 0 & 0 & 1 & 0 & 0 \\ 0 & 1 & 0 & 1 & 0 & 0 & 1 & 0 \\ 0 & 0 & 1 & 0 & 1 & 0 & 0 & 1 \\ 1 & 0 & 0 & 1 & 0 & 1 & 0 & 0 \\ 0 & 1 & 0 & 0 & 1 & 0 & 1 & 0 \end{bmatrix} \begin{bmatrix} 1 & 0 & 0 & 0 & 1 & 1 & 1 & 1 \\ 1 & 1 & 0 & 0 & 0 & 1 & 1 & 1 \\ 1 & 1 & 1 & 0 & 0 & 0 & 1 & 1 \\ 1 & 1 & 1 & 1 & 0 & 0 & 0 & 1 \\ 1 & 1 & 1 & 1 & 1 & 0 & 0 & 0 \\ 0 & 1 & 1 & 1 & 1 & 1 & 0 & 0 \\ 0 & 0 & 1 & 1 & 1 & 1 & 1 & 0 \\ 0 & 0 & 0 & 1 & 1 & 1 & 1 & 1 \end{bmatrix} \begin{bmatrix} b_0 \\ b_1 \\ b_2 \\ b_3 \\ b_4 \\ b_5 \\ b_6 \\ b_7 \end{bmatrix} \oplus \begin{bmatrix} 1 \\ 0 \\ 1 \\ 0 \\ 0 \\ 0 \\ 0 \\ 0 \end{bmatrix} = \begin{bmatrix} 0 & 0 & 1 & 0 & 0 & 1 & 0 & 1 \\ 1 & 0 & 0 & 1 & 0 & 0 & 1 & 0 \\ 0 & 1 & 0 & 0 & 1 & 0 & 0 & 1 \\ 1 & 0 & 1 & 0 & 0 & 1 & 0 & 0 \\ 0 & 1 & 0 & 1 & 0 & 0 & 1 & 0 \\ 0 & 0 & 1 & 0 & 1 & 0 & 0 & 1 \\ 1 & 0 & 0 & 1 & 0 & 1 & 0 & 0 \\ 0 & 1 & 0 & 0 & 1 & 0 & 1 & 0 \end{bmatrix} \begin{bmatrix} 1 \\ 1 \\ 0 \\ 0 \\ 0 \\ 1 \\ 1 \\ 0 \end{bmatrix} \oplus \begin{bmatrix} 1 \\ 0 \\ 1 \\ 0 \\ 0 \\ 0 \\ 0 \\ 0 \end{bmatrix} = \begin{bmatrix} 1 \\ 0 \\ 1 \\ 0 \\ 0 \\ 0 \\ 0 \\ 0 \end{bmatrix}$$

$$\begin{bmatrix} 1 & 0 & 0 & 0 & 0 & 0 & 0 & 0 \\ 0 & 1 & 0 & 0 & 0 & 0 & 0 & 0 \\ 0 & 0 & 1 & 0 & 0 & 0 & 0 & 0 \\ 0 & 0 & 0 & 1 & 0 & 0 & 0 & 0 \\ 0 & 0 & 0 & 0 & 1 & 0 & 0 & 0 \\ 0 & 0 & 0 & 0 & 0 & 1 & 0 & 0 \\ 0 & 0 & 0 & 0 & 0 & 0 & 1 & 0 \\ 0 & 0 & 0 & 0 & 0 & 0 & 0 & 1 \end{bmatrix} \begin{bmatrix} b_0 \\ b_1 \\ b_2 \\ b_3 \\ b_4 \\ b_5 \\ b_6 \\ b_7 \end{bmatrix} \oplus \begin{bmatrix} 1 \\ 0 \\ 1 \\ 0 \\ 0 \\ 0 \\ 0 \\ 0 \end{bmatrix} \oplus \begin{bmatrix} 1 \\ 0 \\ 1 \\ 0 \\ 0 \\ 0 \\ 0 \\ 0 \end{bmatrix} = \begin{bmatrix} b_0 \\ b_1 \\ b_2 \\ b_3 \\ b_4 \\ b_5 \\ b_6 \\ b_7 \end{bmatrix}$$

We have demonstrated that \mathbf{YX} equals the identity matrix, and the $\mathbf{YC} = \mathbf{D}$, so that $\mathbf{YC} \oplus \mathbf{D}$ equals the null vector.

RATIONALE The S-box is designed to be resistant to known cryptanalytic attacks. Specifically, the Rijndael developers sought a design that has a low correlation between input bits and output bits and the property that the output is not a linear mathematical function of the input [DAEM01]. The nonlinearity is due to the use of the multiplicative inverse. In addition, the constant in Equation (6.1) was chosen so that the S-box has no fixed points [S-box(a) = a] and no “opposite fixed points” [S-box(a) = \bar{a}], where \bar{a} is the bitwise complement of a .

Of course, the S-box must be invertible, that is, IS-box[S-box(a)] = a . However, the S-box does not self-inverse in the sense that it is not true that S-box(a) = IS-box(a). For example, S-box({95}) = {2A}, but IS-box({95}) = {AD}.

ShiftRows Transformation

FORWARD AND INVERSE TRANSFORMATIONS The **forward shift row transformation**, called ShiftRows, is depicted in Figure 6.7a. The first row of **State** is not altered. For the second row, a 1-byte circular left shift is performed. For the third row, a 2-byte circular left shift is performed. For the fourth row, a 3-byte circular left shift is performed. The following is an example of ShiftRows.

87	F2	4D	97
EC	6E	4C	90
4A	C3	46	E7
8C	D8	95	A6

→

87	F2	4D	97
6E	4C	90	EC
46	E7	4A	C3
A6	8C	D8	95

The **inverse shift row transformation**, called InvShiftRows, performs the circular shifts in the opposite direction for each of the last three rows, with a 1-byte circular right shift for the second row, and so on.

RATIONALE The shift row transformation is more substantial than it may first appear. This is because the **State**, as well as the cipher input and output, is treated as an array of four 4-byte columns. Thus, on encryption, the first 4 bytes of the plaintext are copied to the first column of **State**, and so on. Furthermore, as will be seen, the round key is applied to **State** column by column. Thus, a row shift moves an individual byte from one column to another, which is a linear distance

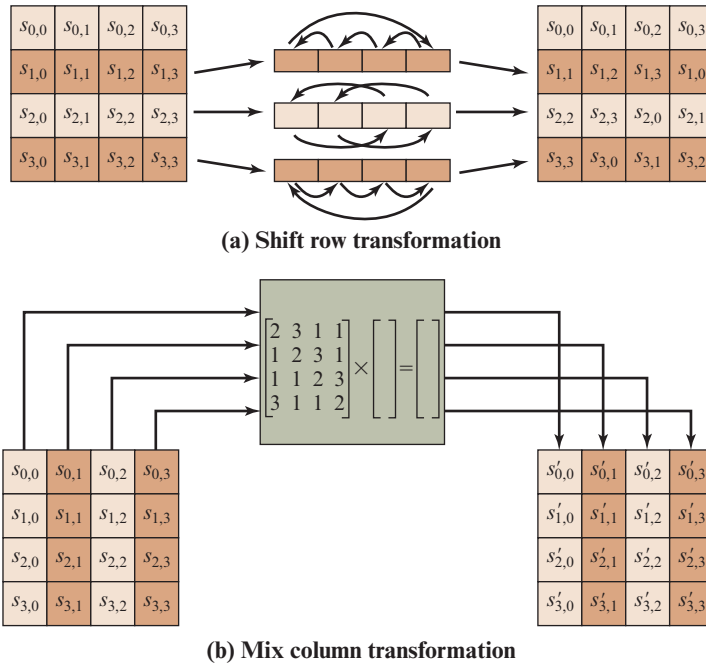

Figure 6.7 AES Row and Column Operations

of a multiple of 4 bytes. Also note that the transformation ensures that the 4 bytes of one column are spread out to four different columns. Figure 6.4 illustrates the effect.

MixColumns Transformation

FORWARD AND INVERSE TRANSFORMATIONS The **forward mix column transformation**, called MixColumns, operates on each column individually. Each byte of a column is mapped into a new value that is a function of all four bytes in that column. The transformation can be defined by the following matrix multiplication on **State** (Figure 6.7b):

$$\begin{bmatrix} 02 & 03 & 01 & 01 \\ 01 & 02 & 03 & 01 \\ 01 & 01 & 02 & 03 \\ 03 & 01 & 01 & 02 \end{bmatrix} \begin{bmatrix} s_{0,0} & s_{0,1} & s_{0,2} & s_{0,3} \\ s_{1,0} & s_{1,1} & s_{1,2} & s_{1,3} \\ s_{2,0} & s_{2,1} & s_{2,2} & s_{2,3} \\ s_{3,0} & s_{3,1} & s_{3,2} & s_{3,3} \end{bmatrix} = \begin{bmatrix} s'_{0,0} & s'_{0,1} & s'_{0,2} & s'_{0,3} \\ s'_{1,0} & s'_{1,1} & s'_{1,2} & s'_{1,3} \\ s'_{2,0} & s'_{2,1} & s'_{2,2} & s'_{2,3} \\ s'_{3,0} & s'_{3,1} & s'_{3,2} & s'_{3,3} \end{bmatrix} \quad (6.3)$$

Each element in the product matrix is the sum of products of elements of one row and one column. In this case, the individual additions and multiplications⁴ are

⁴We follow the convention of FIPS PUB 197 and use the symbol \cdot to indicate multiplication over the finite field $GF(2^8)$ and \oplus to indicate bitwise XOR, which corresponds to addition in $GF(2^8)$.

performed in $GF(2^8)$. The MixColumns transformation on a single column of **State** can be expressed as

$$\begin{aligned}
 s'_{0,j} &= (2 \cdot s_{0,j}) \oplus (3 \cdot s_{1,j}) \oplus s_{2,j} \oplus s_{3,j} \\
 s'_{1,j} &= s_{0,j} \oplus (2 \cdot s_{1,j}) \oplus (3 \cdot s_{2,j}) \oplus s_{3,j} \\
 s'_{2,j} &= s_{0,j} \oplus s_{1,j} \oplus (2 \cdot s_{2,j}) \oplus (3 \cdot s_{3,j}) \\
 s'_{3,j} &= (3 \cdot s_{0,j}) \oplus s_{1,j} \oplus s_{2,j} \oplus (2 \cdot s_{3,j})
 \end{aligned} \tag{6.4}$$

The following is an example of MixColumns:

87	F2	4D	97	→	47	40	A3	4C
6E	4C	90	EC		37	D4	70	9F
46	E7	4A	C3		94	E4	3A	42
A6	8C	D8	95		ED	A5	A6	BC

Let us verify the first column of this example. Recall from Section 5.6 that, in $GF(2^8)$, addition is the bitwise XOR operation and that multiplication can be performed according to the rule established in Equation (5.6). In particular, multiplication of a value by x (i.e., by $\{02\}$) can be implemented as a 1-bit left shift followed by a conditional bitwise XOR with $\{0001\ 1011\}$ if the leftmost bit of the original value (prior to the shift) is 1. Thus, to verify the MixColumns transformation on the first column, we need to show that

$$\begin{aligned}
 (\{02\} \cdot \{87\}) \oplus (\{03\} \cdot \{6E\}) \oplus \{46\} \oplus \{A6\} &= \{47\} \\
 \{87\} \oplus (\{02\} \cdot \{6E\}) \oplus (\{03\} \cdot \{46\}) \oplus \{A6\} &= \{37\} \\
 \{87\} \oplus \{6E\} \oplus (\{02\} \cdot \{46\}) \oplus (\{03\} \cdot \{A6\}) &= \{94\} \\
 (\{03\} \cdot \{87\}) \oplus \{6E\} \oplus \{46\} \oplus (\{02\} \cdot \{A6\}) &= \{ED\}
 \end{aligned}$$

For the first equation, we have $\{02\} \cdot \{87\} = (0000\ 1110) \oplus (0001\ 1011) = (0001\ 0101)$ and $\{03\} \cdot \{6E\} = \{6E\} \oplus (\{02\} \cdot \{6E\}) = (0110\ 1110) \oplus (1101\ 1100) = (1011\ 0010)$. Then,

$$\begin{aligned}
 \{02\} \cdot \{87\} &= 0001\ 0101 \\
 \{03\} \cdot \{6E\} &= 1011\ 0010 \\
 \{46\} &= 0100\ 0110 \\
 \{A6\} &= \underline{1010\ 0110} \\
 &0100\ 0111 = \{47\}
 \end{aligned}$$

The other equations can be similarly verified.

The **inverse mix column transformation**, called `InvMixColumns`, is defined by the following matrix multiplication:

$$\begin{bmatrix} 0E & 0B & 0D & 09 \\ 09 & 0E & 0B & 0D \\ 0D & 09 & 0E & 0B \\ 0B & 0D & 09 & 0E \end{bmatrix} \begin{bmatrix} s_{0,0} & s_{0,1} & s_{0,2} & s_{0,3} \\ s_{1,0} & s_{1,1} & s_{1,2} & s_{1,3} \\ s_{2,0} & s_{2,1} & s_{2,2} & s_{2,3} \\ s_{3,0} & s_{3,1} & s_{3,2} & s_{3,3} \end{bmatrix} = \begin{bmatrix} s'_{0,0} & s'_{0,1} & s'_{0,2} & s'_{0,3} \\ s'_{1,0} & s'_{1,1} & s'_{1,2} & s'_{1,3} \\ s'_{2,0} & s'_{2,1} & s'_{2,2} & s'_{2,3} \\ s'_{3,0} & s'_{3,1} & s'_{3,2} & s'_{3,3} \end{bmatrix} \tag{6.5}$$

It is not immediately clear that Equation (6.5) is the **inverse** of Equation (6.3). We need to show

$$\begin{bmatrix} 0E & 0B & 0D & 09 \\ 09 & 0E & 0B & 0D \\ 0D & 09 & 0E & 0B \\ 0B & 0D & 09 & 0E \end{bmatrix} \begin{bmatrix} 02 & 03 & 01 & 01 \\ 01 & 02 & 03 & 01 \\ 01 & 01 & 02 & 03 \\ 03 & 01 & 01 & 02 \end{bmatrix} \begin{bmatrix} s_{0,0} & s_{0,1} & s_{0,2} & s_{0,3} \\ s_{1,0} & s_{1,1} & s_{1,2} & s_{1,3} \\ s_{2,0} & s_{2,1} & s_{2,2} & s_{2,3} \\ s_{3,0} & s_{3,1} & s_{3,2} & s_{3,3} \end{bmatrix} = \begin{bmatrix} s_{0,0} & s_{0,1} & s_{0,2} & s_{0,3} \\ s_{1,0} & s_{1,1} & s_{1,2} & s_{1,3} \\ s_{2,0} & s_{2,1} & s_{2,2} & s_{2,3} \\ s_{3,0} & s_{3,1} & s_{3,2} & s_{3,3} \end{bmatrix}$$

which is equivalent to showing

$$\begin{bmatrix} 0E & 0B & 0D & 09 \\ 09 & 0E & 0B & 0D \\ 0D & 09 & 0E & 0B \\ 0B & 0D & 09 & 0E \end{bmatrix} \begin{bmatrix} 02 & 03 & 01 & 01 \\ 01 & 02 & 03 & 01 \\ 01 & 01 & 02 & 03 \\ 03 & 01 & 01 & 02 \end{bmatrix} = \begin{bmatrix} 1 & 0 & 0 & 0 \\ 0 & 1 & 0 & 0 \\ 0 & 0 & 1 & 0 \\ 0 & 0 & 0 & 1 \end{bmatrix} \tag{6.6}$$

That is, the inverse transformation matrix times the forward transformation matrix equals the identity matrix. To verify the first column of Equation (6.6), we need to show

$$\begin{aligned} (\{0E\} \cdot \{02\}) \oplus \{0B\} \oplus \{0D\} \oplus (\{09\} \cdot \{03\}) &= \{01\} \\ (\{09\} \cdot \{02\}) \oplus \{0E\} \oplus \{0B\} \oplus (\{0D\} \cdot \{03\}) &= \{00\} \\ (\{0D\} \cdot \{02\}) \oplus \{09\} \oplus \{0E\} \oplus (\{0B\} \cdot \{03\}) &= \{00\} \\ (\{0B\} \cdot \{02\}) \oplus \{0D\} \oplus \{09\} \oplus (\{0E\} \cdot \{03\}) &= \{00\} \end{aligned}$$

For the first equation, we have $\{0E\} \cdot \{02\} = 00011100$ and $\{09\} \cdot \{03\} = \{09\} \oplus (\{09\} \cdot \{02\}) = 00001001 \oplus 00010010 = 00011011$. Then

$$\begin{aligned} \{0E\} \cdot \{02\} &= 00011100 \\ \{0B\} &= 00001011 \\ \{0D\} &= 00001101 \\ \{09\} \cdot \{03\} &= \underline{00011011} \\ &00000001 \end{aligned}$$

The other equations can be similarly verified.

The AES document describes another way of characterizing the MixColumns transformation, which is in terms of polynomial arithmetic. In the standard, MixColumns is defined by considering each column of **State** to be a four-term polynomial with coefficients in $GF(2^8)$. Each column is multiplied modulo $(x^4 + 1)$ by the fixed polynomial $a(x)$, given by

$$a(x) = \{03\}x^3 + \{01\}x^2 + \{01\}x + \{02\} \tag{6.7}$$

Appendix 6A demonstrates that multiplication of each column of **State** by $a(x)$ can be written as the matrix multiplication of Equation (6.3). Similarly, it can be seen that the transformation in Equation (6.5) corresponds to treating

each column as a four-term polynomial and multiplying each column by $b(x)$, given by

$$b(x) = \{0B\}x^3 + \{0D\}x^2 + \{09\}x + \{0E\} \quad (6.8)$$

It readily can be shown that $b(x) = a^{-1}(x) \bmod (x^4 + 1)$.

RATIONALE The coefficients of the matrix in Equation (6.3) are based on a linear code with maximal distance between code words, which ensures a good mixing among the bytes of each column. The mix column transformation combined with the shift row transformation ensures that after a few rounds all output bits depend on all input bits. See [DAEM99] for a discussion.

In addition, the choice of coefficients in MixColumns, which are all {01}, {02}, or {03}, was influenced by implementation considerations. As was discussed, multiplication by these coefficients involves at most a shift and an XOR. The coefficients in InvMixColumns are more formidable to implement. However, encryption was deemed more important than decryption for two reasons:

1. For the CFB and OFB cipher modes (Figures 7.5 and 7.6; described in Chapter 7), only encryption is used.
2. As with any block cipher, AES can be used to construct a message authentication code (Chapter 12), and for this, only encryption is used.

AddRoundKey Transformation

FORWARD AND INVERSE TRANSFORMATIONS In the **forward add round key transformation**, called AddRoundKey, the 128 bits of **State** are bitwise XORed with the 128 bits of the round key. As shown in Figure 6.5b, the operation is viewed as a columnwise operation between the 4 bytes of a **State** column and one word of the round key; it can also be viewed as a byte-level operation. The following is an example of AddRoundKey:

47	40	A3	4C	\oplus	AC	19	28	57	=	EB	59	8B	1B
37	D4	70	9F		77	FA	D1	5C		40	2E	A1	C3
94	E4	3A	42		66	DC	29	00		F2	38	13	42
ED	A5	A6	BC		F3	21	41	6A		1E	84	E7	D6

The first matrix is **State**, and the second matrix is the round key.

The **inverse add round key transformation** is identical to the forward add round key transformation, because the XOR operation is its own inverse.

RATIONALE The add round key transformation is as simple as possible and affects every bit of **State**. The complexity of the round key expansion, plus the complexity of the other stages of AES, ensure security.

Figure 6.8 is another view of a single round of AES, emphasizing the mechanisms and inputs of each transformation.

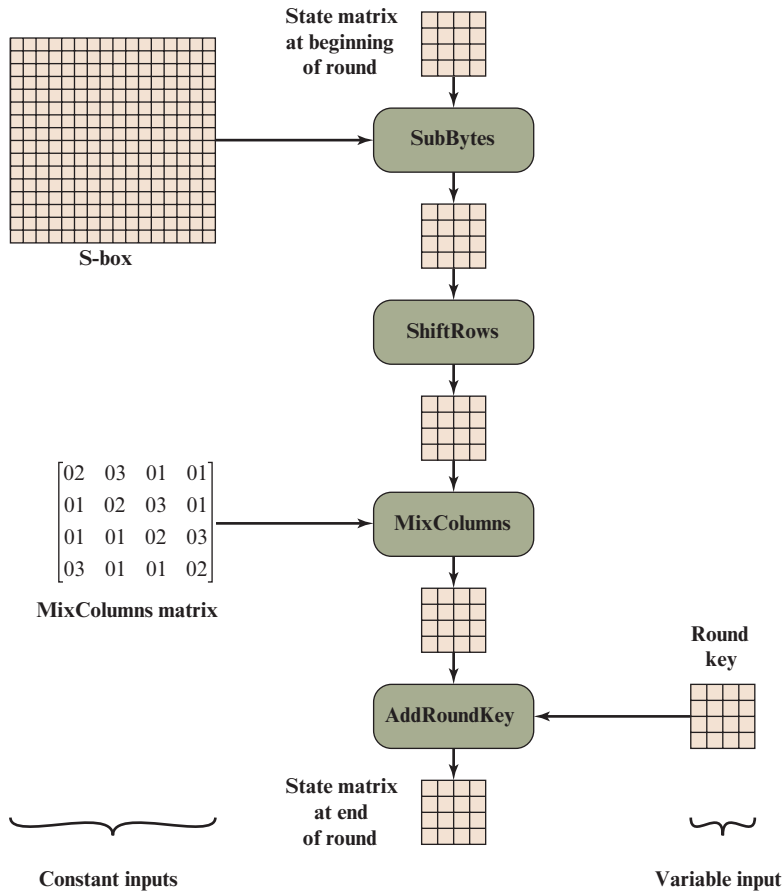

Figure 6.8 Inputs for Single AES Round

6.4 AES KEY EXPANSION

Key Expansion Algorithm

The AES **key expansion** algorithm takes as input a four-word (16-byte) key and produces a linear array of 44 words (176 bytes). This is sufficient to provide a four-word round key for the initial AddRoundKey stage and each of the 10 rounds of the cipher. The pseudocode on the next page describes the expansion.

The key is copied into the first four words of the expanded key. The remainder of the expanded key is filled in four words at a time. Each added word $w[i]$ depends on the immediately preceding word, $w[i - 1]$, and the word four positions back, $w[i - 4]$. In three out of four cases, a simple XOR is used. For a word whose position in the w array is a multiple of 4, a more complex function is used. Figure 6.9 illustrates the generation of the expanded key, using the symbol g to represent that complex function. The function g consists of the following subfunctions.

```

KeyExpansion (byte key[16], word w[44])
{
    word temp
    for (i = 0; i < 4; i++) w[i] = (key[4*i], key[4*i+1],
                                     key[4*i+2],
                                     key[4*i+3]);

    for (i = 4; i < 44; i++)
    {
        temp = w[i - 1];
        if (i mod 4 = 0) temp = SubWord (RotWord (temp))
                                $\oplus$  Rcon[i/4];

        w[i] = w[i-4]  $\oplus$  temp
    }
}
    
```

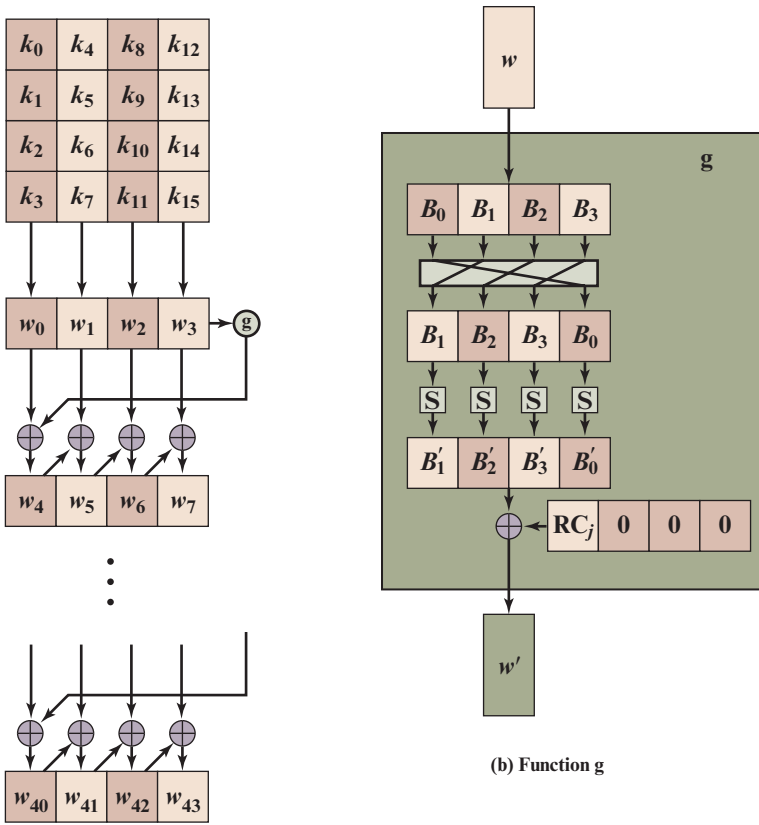

(a) Overall algorithm
Figure 6.9 AES Key Expansion

1. RotWord performs a one-byte circular left shift on a word. This means that an input word $[B_0, B_1, B_2, B_3]$ is transformed into $[B_1, B_2, B_3, B_0]$.
2. SubWord performs a byte substitution on each byte of its input word, using the S-box (Table 6.2a).
3. The result of steps 1 and 2 is XORed with a round constant, $Rcon[j]$.

The round constant is a word in which the three rightmost bytes are always 0. Thus, the effect of an XOR of a word with Rcon is to only perform an XOR on the left-most byte of the word. The round constant is different for each round and is defined as $Rcon[j] = (RC[j], 0, 0, 0)$, with $RC[1] = 1$, $RC[j] = 2 \cdot RC[j - 1]$ and with multiplication defined over the field $GF(2^8)$. The values of $RC[j]$ in hexadecimal are

j	1	2	3	4	5	6	7	8	9	10
RC[j]	01	02	04	08	10	20	40	80	1B	36

For example, suppose that the round key for round 8 is

EA D2 73 21 B5 8D BA D2 31 2B F5 60 7F 8D 29 2F

Then the first 4 bytes (first column) of the round key for round 9 are calculated as shown in Table 6.3

Table 6.3 Example Round Key Calculation

Description	Value
i (decimal)	36
$temp = w[i - 1]$	7F8D292F
RotWord ($temp$)	8D292F7F
SubWord (RotWord ($temp$))	5DA515D2
Rcon (9)	1B000000
SubWord (RotWord ($temp$)) \oplus Rcon (9)	46A515D2
$w[i - 4]$	EAD27321
$w[i] = w[i - 4] \oplus$ SubWord (RotWord ($temp$)) \oplus Rcon (9)	AC7766F3

Rationale

The Rijndael developers designed the expansion key algorithm to be resistant to known cryptanalytic attacks. The inclusion of a round-dependent round constant eliminates the symmetry, or similarity, between the ways in which round keys are generated in different rounds. The specific criteria that were used are [DAEM99]

- Knowledge of a part of the cipher key or round key does not enable calculation of many other round-key bits.
- An invertible transformation [i.e., knowledge of any Nk consecutive words of the expanded key enables regeneration of the entire expanded key ($Nk =$ key size in words)].
- Speed on a wide range of processors.

- Usage of round constants to eliminate symmetries.
- Diffusion of cipher key differences into the round keys; that is, each key bit affects many round key bits.
- Enough nonlinearity to prohibit the full determination of round key differences from cipher key differences only.
- Simplicity of description.

The authors do not quantify the first point on the preceding list, but the idea is that if you know less than Nk consecutive words of either the cipher key or one of the round keys, then it is difficult to reconstruct the remaining unknown bits. The fewer bits one knows, the more difficult it is to do the reconstruction or to determine other bits in the key expansion.

6.5 AN AES EXAMPLE

We now work through an example and consider some of its implications. Although you are not expected to duplicate the example by hand, you will find it informative to study the hex patterns that occur from one step to the next.

For this example, the plaintext is a hexadecimal palindrome. The plaintext, key, and resulting ciphertext are

Plaintext:	0123456789abcdef fedcba9876543210
Key:	0f1571c947d9e8590cb7add6af7f6798
Ciphertext:	ff0b844a0853bf7c6934ab4364148fb9

Results

Table 6.4 shows the expansion of the 16-byte key into 10 round keys. As previously explained, this process is performed word by word, with each four-byte word occupying one column of the word round-key matrix. The left-hand column shows the four round-key words generated for each round. The right-hand column shows

Table 6.4 Key Expansion for AES Example

Key Words	Auxiliary Function
$w_0 = 0f\ 15\ 71\ c9$ $w_1 = 47\ d9\ e8\ 59$ $w_2 = 0c\ b7\ ad\ d6$ $w_3 = af\ 7f\ 67\ 98$	$RotWord(w_3) = 7f\ 67\ 98\ af = x_1$ $SubWord(x_1) = d2\ 85\ 46\ 79 = y_1$ $Rcon(1) = 01\ 00\ 00\ 00$ $y_1 \oplus Rcon(1) = d3\ 85\ 46\ 79 = z_1$
$w_4 = w_0 \oplus z_1 = dc\ 90\ 37\ b0$ $w_5 = w_4 \oplus w_1 = 9b\ 49\ df\ e9$ $w_6 = w_5 \oplus w_2 = 97\ fe\ 72\ 3f$ $w_7 = w_6 \oplus w_3 = 38\ 81\ 15\ a7$	$RotWord(w_7) = 81\ 15\ a7\ 38 = x_2$ $SubWord(x_2) = 0c\ 59\ 5c\ 07 = y_2$ $Rcon(2) = 02\ 00\ 00\ 00$ $y_2 \oplus Rcon(2) = 0e\ 59\ 5c\ 07 = z_2$
$w_8 = w_4 \oplus z_2 = d2\ c9\ 6b\ b7$ $w_9 = w_8 \oplus w_5 = 49\ 80\ b4\ 5e$ $w_{10} = w_9 \oplus w_6 = de\ 7e\ c6\ 61$ $w_{11} = w_{10} \oplus w_7 = e6\ ff\ d3\ c6$	$RotWord(w_{11}) = ff\ d3\ c6\ e6 = x_3$ $SubWord(x_3) = 16\ 66\ b4\ 83 = y_3$ $Rcon(3) = 04\ 00\ 00\ 00$ $y_3 \oplus Rcon(3) = 12\ 66\ b4\ 8e = z_3$

(Continued)

Table 6.4 Continued

Key Words	Auxiliary Function
$w_{12} = w_8 \oplus z_3 = c0\ af\ df\ 39$ $w_{13} = w_{12} \oplus w_9 = 89\ 2f\ 6b\ 67$ $w_{14} = w_{13} \oplus w_{10} = 57\ 51\ ad\ 06$ $w_{15} = w_{14} \oplus w_{11} = b1\ ae\ 7e\ c0$	$RotWord(w_{15}) = ae\ 7e\ c0\ b1 = x_4$ $SubWord(x_4) = e4\ f3\ ba\ c8 = y_4$ $Rcon(4) = 08\ 00\ 00\ 00$ $y_4 \oplus Rcon(4) = ec\ f3\ ba\ c8 = 4$
$w_{16} = w_{12} \oplus z_4 = 2c\ 5c\ 65\ f1$ $w_{17} = w_{16} \oplus w_{13} = a5\ 73\ 0e\ 96$ $w_{18} = w_{17} \oplus w_{14} = f2\ 22\ a3\ 90$ $w_{19} = w_{18} \oplus w_{15} = 43\ 8c\ dd\ 50$	$RotWord(w_{19}) = 8c\ dd\ 50\ 43 = x_5$ $SubWord(x_5) = 64\ c1\ 53\ 1a = y_5$ $Rcon(5) = 10\ 00\ 00\ 00$ $y_5 \oplus Rcon(5) = 74\ c1\ 53\ 1a = z_5$
$w_{20} = w_{16} \oplus z_5 = 58\ 9d\ 36\ eb$ $w_{21} = w_{20} \oplus w_{17} = fd\ ee\ 38\ 7d$ $w_{22} = w_{21} \oplus w_{18} = 0f\ cc\ 9b\ ed$ $w_{23} = w_{22} \oplus w_{19} = 4c\ 40\ 46\ bd$	$RotWord(w_{23}) = 40\ 46\ bd\ 4c = x_6$ $SubWord(x_6) = 09\ 5a\ 7a\ 29 = y_6$ $Rcon(6) = 20\ 00\ 00\ 00$ $y_6 \oplus Rcon(6) = 29\ 5a\ 7a\ 29 = z_6$
$w_{24} = w_{20} \oplus z_6 = 71\ c7\ 4c\ c2$ $w_{25} = w_{24} \oplus w_{21} = 8c\ 29\ 74\ bf$ $w_{26} = w_{25} \oplus w_{22} = 83\ e5\ ef\ 52$ $w_{27} = w_{26} \oplus w_{23} = cf\ a5\ a9\ ef$	$RotWord(w_{27}) = a5\ a9\ ef\ cf = x_7$ $SubWord(x_7) = 06\ d3\ bf\ 8a = y_7$ $Rcon(7) = 40\ 00\ 00\ 00$ $y_7 \oplus Rcon(7) = 46\ d3\ df\ 8a = z_7$
$w_{28} = w_{24} \oplus z_7 = 37\ 14\ 93\ 48$ $w_{29} = w_{28} \oplus w_{25} = bb\ 3d\ e7\ f7$ $w_{30} = w_{29} \oplus w_{26} = 38\ d8\ 08\ a5$ $w_{31} = w_{30} \oplus w_{27} = f7\ 7d\ a1\ 4a$	$RotWord(w_{31}) = 7d\ a1\ 4a\ f7 = x_8$ $SubWord(x_8) = ff\ 32\ d6\ 68 = y_8$ $Rcon(8) = 80\ 00\ 00\ 00$ $y_8 \oplus Rcon(8) = 7f\ 32\ d6\ 68 = z_8$
$w_{32} = w_{28} \oplus z_8 = 48\ 26\ 45\ 20$ $w_{33} = w_{32} \oplus w_{29} = f3\ 1b\ a2\ d7$ $w_{34} = w_{33} \oplus w_{30} = cb\ c3\ aa\ 72$ $w_{35} = w_{34} \oplus w_{32} = 3c\ be\ 0b\ 3$	$RotWord(w_{35}) = be\ 0b\ 38\ 3c = x_9$ $SubWord(x_9) = ae\ 2b\ 07\ eb = y_9$ $Rcon(9) = 1B\ 00\ 00\ 00$ $y_9 \oplus Rcon(9) = b5\ 2b\ 07\ eb = z_9$
$w_{36} = w_{32} \oplus z_9 = fd\ 0d\ 42\ cb$ $w_{37} = w_{36} \oplus w_{33} = 0e\ 16\ e0\ 1c$ $w_{38} = w_{37} \oplus w_{34} = c5\ d5\ 4a\ 6e$ $w_{39} = w_{38} \oplus w_{35} = f9\ 6b\ 41\ 56$	$RotWord(w_{39}) = 6b\ 41\ 56\ f9 = x_{10}$ $SubWord(x_{10}) = 7f\ 83\ b1\ 99 = y_{10}$ $Rcon(10) = 36\ 00\ 00\ 00$ $y_{10} \oplus Rcon(10) = 49\ 83\ b1\ 99 = z_{10}$
$w_{40} = w_{36} \oplus z_{10} = b4\ 8e\ f3\ 52$ $w_{41} = w_{40} \oplus w_{37} = ba\ 98\ 13\ 4e$ $w_{42} = w_{41} \oplus w_{38} = 7f\ 4d\ 59\ 20$ $w_{43} = w_{42} \oplus w_{39} = 86\ 26\ 18\ 76$	

the steps used to generate the auxiliary word used in key expansion. We begin, of course, with the key itself serving as the round key for round 0.

Next, Table 6.5 shows the progression of **State** through the AES encryption process. The first column shows the value of **State** at the start of a round. For the first row, **State** is just the matrix arrangement of the plaintext. The second, third, and fourth columns show the value of **State** for that round after the SubBytes, ShiftRows, and MixColumns transformations, respectively. The fifth column shows the round key. You can verify that these round keys equate with those shown in Table 6.4. The first column shows the value of **State** resulting from the bitwise XOR of **State** after the preceding MixColumns with the round key for the preceding round.

Avalanche Effect

If a small change in the key or plaintext were to produce a corresponding small change in the ciphertext, this might be used to effectively reduce the size of the

Table 6.5 AES Example

Start of Round	After SubBytes	After ShiftRows	After MixColumns	Round Key
01 89 fe 76 23 ab dc 54 45 cd ba 32 67 ef 98 10				0f 47 0c af 15 d9 b7 7f 71 e8 ad 67 c9 59 d6 98
0e ce f2 d9 36 72 6b 2b 34 25 17 55 ae b6 4e 8d	ab 8b 89 35 05 40 7f f1 18 3f f0 fc e4 4e 2f c4	ab 8b 89 35 40 7f f1 05 f0 fc 18 3f c4 e4 4e 2f	b9 94 57 75 e4 8e 16 51 47 20 9a 3f c5 d6 f5 3b	dc 9b 97 38 90 49 fe 81 37 df 72 15 b0 e9 3f a7
65 0f c0 4d 74 c7 e8 d0 70 ff e8 2a 75 3f ca 9c	4d 76 ba e3 92 c6 9b 70 51 16 9b e5 9d 75 74 de	4d 76 ba e3 c6 9b 70 92 9b e5 51 16 de 9d 75 74	8e 22 db 12 b2 f2 dc 92 df 80 f7 c1 2d c5 1e 52	d2 49 de e6 c9 80 7e ff 6b b4 c6 d3 b7 5e 61 c6
5c 6b 05 f4 7b 72 a2 6d b4 34 31 12 9a 9b 7f 94	4a 7f 6b bf 21 40 3a 3c 8d 18 c7 c9 b8 14 d2 22	4a 7f 6b bf 40 3a 3c 21 c7 c9 8d 18 22 b8 14 d2	b1 c1 0b cc ba f3 8b 07 f9 1f 6a c3 1d 19 24 5c	c0 89 57 b1 af 2f 51 ae df 6b ad 7e 39 67 06 c0
71 48 5c 7d 15 dc da a9 26 74 c7 bd 24 7e 22 9c	a3 52 4a ff 59 86 57 d3 f7 92 c6 7a 36 f3 93 de	a3 52 4a ff 86 57 d3 59 c6 7a f7 92 de 36 f3 93	d4 11 fe 0f 3b 44 06 73 cb ab 62 37 19 b7 07 ec	2c a5 f2 43 5c 73 22 8c 65 0e a3 dd f1 96 90 50
f8 b4 0c 4c 67 37 24 ff ae a5 c1 ea e8 21 97 bc	41 8d fe 29 85 9a 36 16 e4 06 78 87 9b fd 88 65	41 8d fe 29 9a 36 16 85 78 87 e4 06 65 9b fd 88	2a 47 c4 48 83 e8 18 ba 84 18 27 23 eb 10 0a f3	58 fd 0f 4c 9d ee cc 40 36 38 9b 46 eb 7d ed bd
72 ba cb 04 1e 06 d4 fa b2 20 bc 65 00 6d e7 4e	40 f4 1f f2 72 6f 48 2d 37 b7 65 4d 63 3c 94 2f	40 f4 1f f2 6f 48 2d 72 65 4d 37 b7 2f 63 3c 94	7b 05 42 4a 1e d0 20 40 94 83 18 52 94 c4 43 fb	71 8c 83 cf c7 29 e5 a5 4c 74 ef a9 c2 bf 52 ef
0a 89 c1 85 d9 f9 c5 e5 d8 f7 f7 fb 56 7b 11 14	67 a7 78 97 35 99 a6 d9 61 68 68 0f b1 21 82 fa	67 a7 78 97 99 a6 d9 35 68 0f 61 68 fa b1 21 82	ec 1a c0 80 0c 50 53 c7 3b d7 00 ef b7 22 72 e0	37 bb 38 f7 14 3d d8 7d 93 e7 08 a1 48 f7 a5 4a
db a1 f8 77 18 6d 8b ba a8 30 08 4e ff d5 d7 aa	b9 32 41 f5 ad 3c 3d f4 c2 04 30 2f 16 03 0e ac	b9 32 41 f5 3c 3d f4 ad 30 2f c2 04 ac 16 03 0e	b1 1a 44 17 3d 2f ec b6 0a 6b 2f 42 9f 68 f3 b1	48 f3 cb 3c 26 1b c3 be 45 a2 aa 0b 20 d7 72 38
f9 e9 8f 2b 1b 34 2f 08 4f c9 85 49 bf bf 81 89	99 1e 73 f1 af 18 15 30 84 dd 97 3b 08 08 0c a7	99 1e 73 f1 18 15 30 af 97 3b 84 dd a7 08 08 0c	31 30 3a c2 ac 71 8c c4 46 65 48 eb 6a 1c 31 62	fd 0e c5 f9 0d 16 d5 6b 42 e0 4a 41 cb 1c 6e 56
cc 3e ff 3b a1 67 59 af 04 85 02 aa a1 00 5f 34	4b b2 16 e2 32 85 cb 79 f2 97 77 ac 32 63 cf 18	4b b2 16 e2 85 cb 79 32 77 ac f2 97 18 32 63 cf		b4 ba 7f 86 8e 98 4d 26 f3 13 59 18 52 4e 20 76
ff 08 69 64 0b 53 34 14 84 bf ab 8f 4a 7c 43 b9				

Table 6.6 Avalanche Effect in AES: Change in Plaintext

Round		Number of Bits that Differ
	0123456789abcdef fedcba9876543210 0023456789abcdef fedcba9876543210	1
0	0e3634aece7225b6f26b174ed92b5588 0f3634aece7225b6f26b174ed92b5588	1
1	657470750fc7ff3fc0e8e8ca4dd02a9c c4a9ad090fc7ff3fc0e8e8ca4dd02a9c	20
2	5c7bb49a6b72349b05a2317ff46d1294 fe2ae569f7ee8bb8c1f5a2bb37ef53d5	58
3	7115262448dc747e5cdac7227da9bd9c ec093dfb7c45343d689017507d485e62	59
4	f867aee8b437a5210c24c1974cf feabc 43efdb697244df808e8d9364ee0ae6f5	61
5	721eb200ba06206dcbd4bce704fa654e 7b28a5d5ed643287e006c099bb375302	68
6	0ad9d85689f9f77bc1c5f71185e5fb14 3bc2d8b6798d8ac4fe36ald891ac181a	64
7	db18a8ffa16d30d5f88b08d777ba4eaa 9fb8b5452023c70280e5c4bb9e555a4b	67
8	f91b4fbfe934c9bf8f2f85812b084989 20264e1126b219aef7feb3f9b2d6de40	65
9	cca104a13e678500ff59025f3bafaa34 b56a0341b2290ba7dfdfbddcd8578205	61
10	ff0b844a0853bf7c6934ab4364148fb9 612b89398d0600cde116227ce72433f0	58

plaintext (or key) space to be searched. What is desired is the **avalanche effect**, in which a small change in plaintext or key produces a large change in the ciphertext.

Using the example from Table 6.5, Table 6.6 shows the result when the eighth bit of the plaintext is changed. The second column of the table shows the value of the **State** matrix at the end of each round for the two plaintexts. Note that after just one round, 20 bits of the **State** vector differ. After two rounds, close to half the bits differ. This magnitude of difference propagates through the remaining rounds. A bit difference in approximately half the positions in the most desirable outcome. Clearly, if almost all the bits are changed, this would be logically equivalent to almost none of the bits being changed. Put another way, if we select two plaintexts at random, we would expect the two plaintexts to differ in about half of the bit positions and the two ciphertexts to also differ in about half the positions.

Table 6.7 shows the change in **State** matrix values when the same plaintext is used and the two keys differ in the eighth bit. That is, for the second case, the key is 0e1571c947d9e8590cb7add6af7f6798. Again, one round produces a significant change, and the magnitude of change after all subsequent rounds is roughly half the bits. Thus, based on this example, AES exhibits a very strong avalanche effect.

Table 6.7 Avalanche Effect in AES: Change in Key

Round		Number of Bits that Differ
	0123456789abcdeffedcba9876543210 0123456789abcdeffedcba9876543210	0
0	0e3634aece7225b6f26b174ed92b5588 0f3634aece7225b6f26b174ed92b5588	1
1	657470750fc7ff3fc0e8e8ca4dd02a9c c5a9ad090ec7ff3fc1e8e8ca4cd02a9c	22
2	5c7bb49a6b72349b05a2317ff46d1294 90905fa9563356d15f3760f3b8259985	58
3	7115262448dc747e5cdac7227da9bd9c 18aeb7aa794b3b66629448d575c7cebf	67
4	f867aee8b437a5210c24c1974cffeabc f81015f993c978a876ae017cb49e7eec	63
5	721eb200ba06206dcbd4bce704fa654e 5955c91b4e769f3cb4a94768e98d5267	81
6	0ad9d85689f9f77bc1c5f71185e5fb14 dc60a24d137662181e45b8d3726b2920	70
7	db18a8ffa16d30d5f88b08d777ba4eaa fe8343b8f88bef66cab7e977d005a03c	74
8	f91b4fbfe934c9bf8f2f85812b084989 da7dad581d1725c5b72fa0f9d9d1366a	67
9	cca104a13e678500ff59025f3bafaa34 0ccb4c66bbfd912f4b511d72996345e0	59
10	ff0b844a0853bf7c6934ab4364148fb9 fc8923ee501a7d207ab670686839996b	53

Note that this avalanche effect is stronger than that for DES (Table 4.2), which requires three rounds to reach a point at which approximately half the bits are changed, both for a bit change in the plaintext and a bit change in the key.

6.6 AES IMPLEMENTATION

Equivalent Inverse Cipher

As was mentioned, the AES decryption cipher is not identical to the encryption cipher (Figure 6.3). That is, the sequence of transformations for decryption differs from that for encryption, although the form of the key schedules for encryption and decryption is the same. This has the disadvantage that two separate software or firmware modules are needed for applications that require both encryption and decryption. There is, however, an equivalent version of the decryption algorithm that has the same structure as the encryption algorithm. The equivalent version has the same sequence of transformations as the encryption algorithm (with transformations replaced by their inverses). To achieve this equivalence, a change in key schedule is needed.

Two separate changes are needed to bring the decryption structure in line with the encryption structure. As illustrated in Figure 6.3, an encryption round has the structure SubBytes, ShiftRows, MixColumns, AddRoundKey. The standard decryption round has the structure InvShiftRows, InvSubBytes, AddRoundKey, InvMixColumns. Thus, the first two stages of the decryption round need to be interchanged, and the second two stages of the decryption round need to be interchanged.

INTERCHANGING INVSHIFTROWS AND INVSUBBYTES InvShiftRows affects the sequence of bytes in **State** but does not alter byte contents and does not depend on byte contents to perform its transformation. InvSubBytes affects the contents of bytes in **State** but does not alter byte sequence and does not depend on byte sequence to perform its transformation. Thus, these two operations commute and can be interchanged. For a given **State** S_i ,

$$\text{InvShiftRows} [\text{InvSubBytes} (S_i)] = \text{InvSubBytes} [\text{InvShiftRows} (S_i)]$$

INTERCHANGING ADDROUNDKEY AND INV MIXCOLUMNS The transformations AddRoundKey and InvMixColumns do not alter the sequence of bytes in **State**. If we view the key as a sequence of words, then both AddRoundKey and InvMixColumns operate on **State** one column at a time. These two operations are linear with respect to the column input. That is, for a given **State** S_i and a given round key w_j ,

$$\text{InvMixColumns} (S_i \oplus w_j) = [\text{InvMixColumns} (S_i)] \oplus [\text{InvMixColumns} (w_j)]$$

To see this, suppose that the first column of **State** S_i is the sequence (y_0, y_1, y_2, y_3) and the first column of the round key w_j is (k_0, k_1, k_2, k_3) . Then we need to show

$$\begin{bmatrix} 0E & 0B & 0D & 09 \\ 09 & 0E & 0B & 0D \\ 0D & 09 & 0E & 0B \\ 0B & 0D & 09 & 0E \end{bmatrix} \begin{bmatrix} y_0 \oplus k_0 \\ y_1 \oplus k_1 \\ y_2 \oplus k_2 \\ y_3 \oplus k_3 \end{bmatrix} = \begin{bmatrix} 0E & 0B & 0D & 09 \\ 09 & 0E & 0B & 0D \\ 0D & 09 & 0E & 0B \\ 0B & 0D & 09 & 0E \end{bmatrix} \begin{bmatrix} y_0 \\ y_1 \\ y_2 \\ y_3 \end{bmatrix} \oplus \begin{bmatrix} 0E & 0B & 0D & 09 \\ 09 & 0E & 0B & 0D \\ 0D & 09 & 0E & 0B \\ 0B & 0D & 09 & 0E \end{bmatrix} \begin{bmatrix} k_0 \\ k_1 \\ k_2 \\ k_3 \end{bmatrix}$$

Let us demonstrate that for the first column entry. We need to show

$$\begin{aligned} & [\{0E\} \cdot (y_0 \oplus k_0)] \oplus [\{0B\} \cdot (y_1 \oplus k_1)] \oplus [\{0D\} \cdot (y_2 \oplus k_2)] \oplus [\{09\} \cdot (y_3 \oplus k_3)] \\ &= [\{0E\} \cdot y_0] \oplus [\{0B\} \cdot y_1] \oplus [\{0D\} \cdot y_2] \oplus [\{09\} \cdot y_3] \oplus \\ & \quad [\{0E\} \cdot k_0] \oplus [\{0B\} \cdot k_1] \oplus [\{0D\} \cdot k_2] \oplus [\{09\} \cdot k_3] \end{aligned}$$

This equation is valid by inspection. Thus, we can interchange AddRoundKey and InvMixColumns, provided that we first apply InvMixColumns to the round key. Note that we do not need to apply InvMixColumns to the round key for the input to the first AddRoundKey transformation (preceding the first round) nor to the last AddRoundKey transformation (in round 10). This is because these two AddRoundKey transformations are not interchanged with InvMixColumns to produce the equivalent decryption algorithm.

Figure 6.10 illustrates the equivalent decryption algorithm.

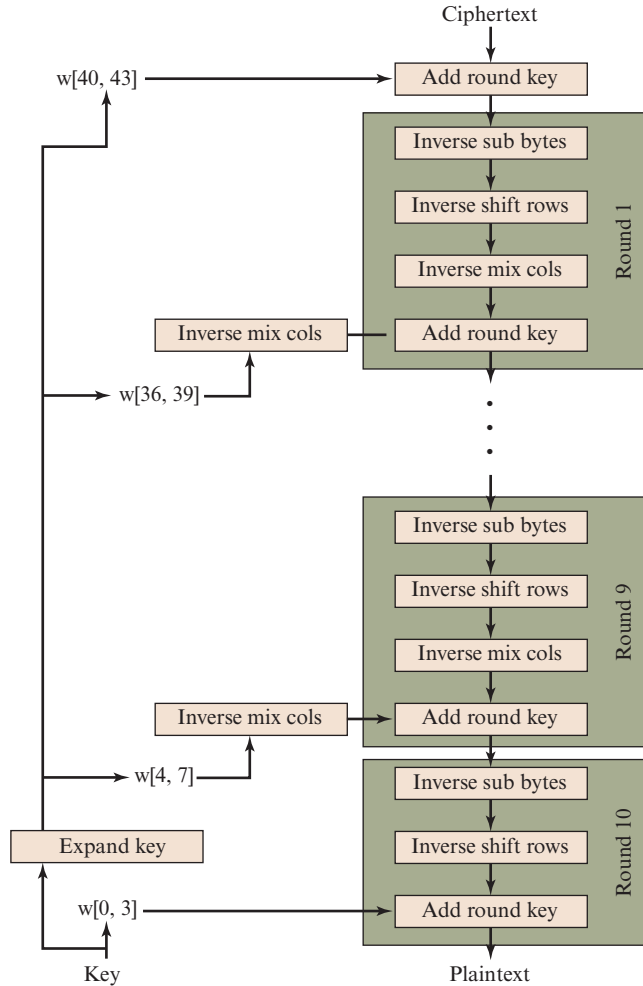

Figure 6.10 Equivalent Inverse Cipher

Implementation Aspects

The Rijndael proposal [DAEM99] provides some suggestions for efficient implementation on 8-bit processors, typical for current smart cards, and on 32-bit processors, typical for PCs.

8-BIT PROCESSOR AES can be implemented very efficiently on an 8-bit processor. **AddRoundKey** is a bitwise XOR operation. **ShiftRows** is a simple byte-shifting operation. **SubBytes** operates at the byte level and only requires a table of 256 bytes.

The transformation **MixColumns** requires matrix multiplication in the field $GF(2^8)$, which means that all operations are carried out on bytes. **MixColumns** only requires multiplication by $\{02\}$ and $\{03\}$, which, as we have seen, involved simple shifts, conditional XORs, and XORs. This can be implemented in a more efficient

way that eliminates the shifts and conditional XORs. Equation set (6.4) shows the equations for the MixColumns transformation on a single column. Using the identity $\{03\} \cdot x = (\{02\} \cdot x) \oplus x$, we can rewrite Equation set (6.4) as follows.

$$\begin{aligned}
 Tmp &= s_{0,j} \oplus s_{1,j} \oplus s_{2,j} \oplus s_{3,j} \\
 s'_{0,j} &= s_{0,j} \oplus Tmp \oplus [2 \cdot (s_{0,j} \oplus s_{1,j})] \\
 s'_{1,j} &= s_{1,j} \oplus Tmp \oplus [2 \cdot (s_{1,j} \oplus s_{2,j})] \\
 s'_{2,j} &= s_{2,j} \oplus Tmp \oplus [2 \cdot (s_{2,j} \oplus s_{3,j})] \\
 s'_{3,j} &= s_{3,j} \oplus Tmp \oplus [2 \cdot (s_{3,j} \oplus s_{0,j})]
 \end{aligned} \tag{6.9}$$

Equation set (6.9) is verified by expanding and eliminating terms.

The multiplication by $\{02\}$ involves a shift and a conditional XOR. Such an implementation may be vulnerable to a timing attack of the sort described in Section 4.4. To counter this attack and to increase processing efficiency at the cost of some storage, the multiplication can be replaced by a table lookup. Define the 256-byte table X2, such that $X2[i] = \{02\} \cdot i$. Then Equation set (6.9) can be rewritten as

$$\begin{aligned}
 Tmp &= s_{0,j} \oplus s_{1,j} \oplus s_{2,j} \oplus s_{3,j} \\
 s'_{0,j} &= s_{0,j} \oplus Tmp \oplus X2[s_{0,j} \oplus s_{1,j}] \\
 s'_{1,j} &= s_{1,j} \oplus Tmp \oplus X2[s_{1,j} \oplus s_{2,j}] \\
 s'_{2,j} &= s_{2,j} \oplus Tmp \oplus X2[s_{2,j} \oplus s_{3,j}] \\
 s'_{3,j} &= s_{3,j} \oplus Tmp \oplus X2[s_{3,j} \oplus s_{0,j}]
 \end{aligned}$$

32-BIT PROCESSOR The implementation described in the preceding subsection uses only 8-bit operations. For a 32-bit processor, a more efficient implementation can be achieved if operations are defined on 32-bit words. To show this, we first define the four transformations of a round in algebraic form. Suppose we begin with a **State** matrix consisting of elements $a_{i,j}$ and a round-key matrix consisting of elements $k_{i,j}$. Then the transformations can be expressed as follows.

SubBytes	$b_{i,j} = S[a_{i,j}]$
ShiftRows	$ \begin{bmatrix} c_{0,j} \\ c_{1,j} \\ c_{2,j} \\ c_{3,j} \end{bmatrix} = \begin{bmatrix} b_{0,j} \\ b_{1,j-1} \\ b_{2,j-2} \\ b_{3,j-3} \end{bmatrix} $
MixColumns	$ \begin{bmatrix} d_{0,j} \\ d_{1,j} \\ d_{2,j} \\ d_{3,j} \end{bmatrix} = \begin{bmatrix} 02 & 03 & 01 & 01 \\ 01 & 02 & 03 & 01 \\ 01 & 01 & 02 & 03 \\ 03 & 01 & 01 & 02 \end{bmatrix} \begin{bmatrix} c_{0,j} \\ c_{1,j} \\ c_{2,j} \\ c_{3,j} \end{bmatrix} $
AddRoundKey	$ \begin{bmatrix} e_{0,j} \\ e_{1,j} \\ e_{2,j} \\ e_{3,j} \end{bmatrix} = \begin{bmatrix} d_{0,j} \\ d_{1,j} \\ d_{2,j} \\ d_{3,j} \end{bmatrix} \oplus \begin{bmatrix} k_{0,j} \\ k_{1,j} \\ k_{2,j} \\ k_{3,j} \end{bmatrix} $

In the ShiftRows equation, the column indices are taken mod 4. We can combine all of these expressions into a single equation:

$$\begin{aligned}
 \begin{bmatrix} e_{0,j} \\ e_{1,j} \\ e_{2,j} \\ e_{3,j} \end{bmatrix} &= \begin{bmatrix} 02 & 03 & 01 & 01 \\ 01 & 02 & 03 & 01 \\ 01 & 01 & 02 & 03 \\ 03 & 01 & 01 & 02 \end{bmatrix} \begin{bmatrix} S[a_{0,j}] \\ S[a_{1,j-1}] \\ S[a_{2,j-2}] \\ S[a_{3,j-3}] \end{bmatrix} \oplus \begin{bmatrix} k_{0,j} \\ k_{1,j} \\ k_{2,j} \\ k_{3,j} \end{bmatrix} \\
 &= \left(\begin{bmatrix} 02 \\ 01 \\ 01 \\ 03 \end{bmatrix} \cdot S[a_{0,j}] \right) \oplus \left(\begin{bmatrix} 03 \\ 02 \\ 01 \\ 01 \end{bmatrix} \cdot S[a_{1,j-1}] \right) \oplus \left(\begin{bmatrix} 01 \\ 03 \\ 02 \\ 01 \end{bmatrix} \cdot S[a_{2,j-2}] \right) \\
 &\quad \oplus \left(\begin{bmatrix} 01 \\ 01 \\ 03 \\ 02 \end{bmatrix} \cdot S[a_{3,j-3}] \right) \oplus \begin{bmatrix} k_{0,j} \\ k_{1,j} \\ k_{2,j} \\ k_{3,j} \end{bmatrix}
 \end{aligned}$$

In the second equation, we are expressing the matrix multiplication as a linear combination of vectors. We define four 256-word (1024-byte) tables as follows.

$T_0[x] = \left(\begin{bmatrix} 02 \\ 01 \\ 01 \\ 03 \end{bmatrix} \cdot S[x] \right)$	$T_1[x] = \left(\begin{bmatrix} 03 \\ 02 \\ 01 \\ 01 \end{bmatrix} \cdot S[x] \right)$	$T_2[x] = \left(\begin{bmatrix} 01 \\ 03 \\ 02 \\ 01 \end{bmatrix} \cdot S[x] \right)$	$T_3[x] = \left(\begin{bmatrix} 01 \\ 01 \\ 03 \\ 02 \end{bmatrix} \cdot S[x] \right)$
---	---	---	---

Thus, each table takes as input a byte value and produces a column vector (a 32-bit word) that is a function of the S-box entry for that byte value. These tables can be calculated in advance.

We can define a round function operating on a column in the following fashion.

$$\begin{bmatrix} s'_{0,j} \\ s'_{1,j} \\ s'_{2,j} \\ s'_{3,j} \end{bmatrix} = T_0[s_{0,j}] \oplus T_1[s_{1,j-1}] \oplus T_2[s_{2,j-2}] \oplus T_3[s_{3,j-3}] \oplus \begin{bmatrix} k_{0,j} \\ k_{1,j} \\ k_{2,j} \\ k_{3,j} \end{bmatrix}$$

As a result, an implementation based on the preceding equation requires only four table lookups and four XORs per column per round, plus 4 Kbytes to store the table. The developers of Rijndael believe that this compact, efficient implementation was probably one of the most important factors in the selection of Rijndael for AES.

6.7 KEY TERMS, REVIEW QUESTIONS, AND PROBLEMS

Key Terms

Advanced Encryption Standard (AES) avalanche effect	field finite field	key expansion S-box
--	-----------------------	------------------------

Review Questions

- 6.1 What was the original set of criteria used by NIST to evaluate candidate AES ciphers?
- 6.2 What was the final set of criteria used by NIST to evaluate candidate AES ciphers?
- 6.3 How many different key sizes are approved for AES?
- 6.4 What is the purpose of the **State** array?
- 6.5 How is the S-box constructed?
- 6.6 What is the rationale behind the choice of the specific S-box in the AES?
- 6.7 Briefly describe ShiftRows.
- 6.8 How many bytes in **State** are affected by ShiftRows?
- 6.9 Why are different round constants used in the key expansion of AES?
- 6.10 Briefly describe AddRoundKey.
- 6.11 Briefly describe the key expansion algorithm.
- 6.12 What is the difference between SubBytes and SubWord?
- 6.13 What is the difference between ShiftRows and RotWord?
- 6.14 How is the avalanche effect different in AES in comparison to DES? Quantify it in terms of number of rounds.

Problems

- 6.1 In the discussion of MixColumns and InvMixColumns, it was stated that

$$b(x) = a^{-1}(x) \bmod(x^4 + 1)$$

where $a(x) = \{03\}x^3 + \{01\}x^2 + \{01\}x + \{02\}$ and $b(x) = \{0B\}x^3 + \{0D\}x^2 + \{09\}x + \{0E\}$. Show that this is true.

- 6.2
 - a. What is $\{02\}^{-1}$ in $\text{GF}(2^8)$?
 - b. Verify the entry for $\{02\}$ in the S-box.
- 6.3 Show the first eight words of the key expansion for a 128-bit key of all ones.
- 6.4 Given the plaintext $\{0F0E0D0C0B0A09080706050403020100\}$ and the key $\{02020202020202020202020202020202\}$:
 - a. Show the original contents of **State**, displayed as a 4×4 matrix.
 - b. Show the value of **State** after initial AddRoundKey.
 - c. Show the value of **State** after SubBytes.
 - d. Show the value of **State** after ShiftRows.
 - e. Show the value of **State** after MixColumns.
- 6.5 Verify Equation (6.11) in Appendix 6A. That is, show that $x^i \bmod(x^4 + 1) = x^{i \bmod 4}$.

- 6.6** For each of the following elements of DES, indicate the differences with the comparable element in AES.
- Key size
 - Block size
 - S-box
 - Key expansion function
 - Initial and final permutation
- 6.7** How are the coefficients chosen in the specific matrix used in the MixColumns?
- 6.8** In the subsection on implementation aspects, it is mentioned that AES can be implemented on 32-bit processors by using certain table lookups. Explain this technique and compute the overall cost of implementing one round of AES using the technique.
- 6.9** Compute the output of the MixColumns transformation for the following sequence of input bytes “A1 B2 C3 D4.” Apply the InvMixColumns transformation to the obtained result to verify your calculations. Change the first byte of the input from “A1” to “A3”; perform the MixColumns transformation again for the new input, and determine how many bits have changed in the output.
- 6.10** Use the key 1010 1001 1100 0011 to encrypt the plaintext “hi” as expressed in ASCII as 0110 1000 0110 1001. The designers of S-AES got the ciphertext 0011 1110 1111 1011. Did you?
- 6.11** Show that the matrix given here, with entries in $GF(2^4)$, is the inverse of the matrix used in the MixColumns step of S-AES.

$$\begin{pmatrix} x^3 + 1 & x \\ x & x^3 + 1 \end{pmatrix}$$

- 6.12** Carefully write up a complete decryption of the ciphertext 0011 1110 1111 1011 using the key 1010 1001 1100 0011 and the S-AES algorithm. You should get the plaintext we started with in Problem 6.10. Note that the inverse of the S-boxes can be done with a reverse table lookup. The inverse of the MixColumns step is given by the matrix in the previous problem.
- 6.13** The decryption algorithm in AES uses a sequence of operations that is the reverse of the sequence used in the encryption algorithm. This has the disadvantage that different circuits or codes are required to implement the encryption and decryption functionality. Explain how it is possible to modify the decryption algorithm such that we can bring the decryption structure in line with the encryption structure in AES.

Programming Problems

- 6.1** Create software that can encrypt and decrypt using S-AES. *Test data:* A binary plaintext of 0110 1111 0110 1011 encrypted with a binary key of 1010 0111 0011 1011 should give a binary ciphertext of 0000 0111 0011 1000. Decryption should work correspondingly.
- 6.2** Implement a differential cryptanalysis attack on 1-round S-AES.

APPENDIX 6A POLYNOMIALS WITH COEFFICIENTS IN $GF(2^8)$

In Section 5.5, we discussed polynomial arithmetic in which the coefficients are in Z_p and the polynomials are defined modulo a polynomial $m(x)$ whose highest power is some integer n . In this case, addition and multiplication of coefficients occurred within the field Z_p ; that is, addition and multiplication were performed modulo p .

The AES document defines polynomial arithmetic for polynomials of degree 3 or less with coefficients in $\text{GF}(2^8)$. The following rules apply.

1. Addition is performed by adding corresponding coefficients in $\text{GF}(2^8)$. As was pointed out Section 5.4, if we treat the elements of $\text{GF}(2^8)$ as 8-bit strings, then addition is equivalent to the XOR operation. So, if we have

$$a(x) = a_3x^3 + a_2x^2 + a_1x + a_0 \quad (6.10)$$

and

$$b(x) = b_3x^3 + b_2x^2 + b_1x + b_0 \quad (6.11)$$

then

$$a(x) + b(x) = (a_3 \oplus b_3)x^3 + (a_2 \oplus b_2)x^2 + (a_1 \oplus b_1)x + (a_0 \oplus b_0)$$

2. Multiplication is performed as in ordinary polynomial multiplication with two refinements:
 - a. Coefficients are multiplied in $\text{GF}(2^8)$.
 - b. The resulting polynomial is reduced mod $(x^4 + 1)$.

We need to keep straight which polynomial we are talking about. Recall from Section 5.6 that each element of $\text{GF}(2^8)$ is a polynomial of degree 7 or less with binary coefficients, and multiplication is carried out modulo a polynomial of degree 8. Equivalently, each element of $\text{GF}(2^8)$ can be viewed as an 8-bit byte whose bit values correspond to the binary coefficients of the corresponding polynomial. For the sets defined in this section, we are defining a polynomial ring in which each element of this ring is a polynomial of degree 3 or less with coefficients in $\text{GF}(2^8)$, and multiplication is carried out modulo a polynomial of degree 4. Equivalently, each element of this ring can be viewed as a 4-byte word whose byte values are elements of $\text{GF}(2^8)$ that correspond to the 8-bit coefficients of the corresponding polynomial.

We denote the modular product of $a(x)$ and $b(x)$ by $a(x) \oplus b(x)$. To compute $d(x) = a(x) \oplus b(x)$, the first step is to perform a multiplication without the modulo operation and to collect coefficients of like powers. Let us express this as $c(x) = a(x) \times b(x)$. Then

$$c(x) = c_6x^6 + c_5x^5 + c_4x^4 + c_3x^3 + c_2x^2 + c_1x + c_0 \quad (6.12)$$

where

$$\begin{aligned} c_0 &= a_0 \cdot b_0 & c_4 &= (a_3 \cdot b_1) \oplus (a_2 \cdot b_2) \oplus (a_1 \cdot b_3) \\ c_1 &= (a_1 \cdot b_0) \oplus (a_0 \cdot b_1) & c_5 &= (a_3 \cdot b_2) \oplus (a_2 \cdot b_3) \\ c_2 &= (a_2 \cdot b_0) \oplus (a_1 \cdot b_1) \oplus (a_0 \cdot b_2) & c_6 &= a_3 \cdot b_3 \\ c_3 &= (a_3 \cdot b_0) \oplus (a_2 \cdot b_1) \oplus (a_1 \cdot b_2) \oplus (a_0 \cdot b_3) \end{aligned}$$

The final step is to perform the modulo operation

$$d(x) = c(x) \bmod (x^4 + 1)$$

That is, $d(x)$ must satisfy the equation

$$c(x) = [(x^4 + 1) \times q(x)] \oplus d(x)$$

such that the degree of $d(x)$ is 3 or less.

A practical technique for performing multiplication over this polynomial ring is based on the observation that

$$x^i \bmod (x^4 + 1) = x^{i \bmod 4} \quad (6.13)$$

If we now combine Equations (6.12) and (6.13), we end up with

$$\begin{aligned} d(x) &= c(x) \bmod (x^4 + 1) \\ &= [c_6x^6 + c_5x^5 + c_4x^4 + c_3x^3 + c_2x^2 + c_1x + c_0] \bmod (x^4 + 1) \\ &= c_3x^3 + (c_2 \oplus c_6)x^2 + (c_1 \oplus c_5)x + (c_0 \oplus c_4) \end{aligned}$$

Expanding the c_i coefficients, we have the following equations for the coefficients of $d(x)$.

$$\begin{aligned} d_0 &= (a_0 \cdot b_0) \oplus (a_3 \cdot b_1) \oplus (a_2 \cdot b_2) \oplus (a_1 \cdot b_3) \\ d_1 &= (a_1 \cdot b_0) \oplus (a_0 \cdot b_1) \oplus (a_3 \cdot b_2) \oplus (a_2 \cdot b_3) \\ d_2 &= (a_2 \cdot b_0) \oplus (a_1 \cdot b_1) \oplus (a_0 \cdot b_2) \oplus (a_3 \cdot b_3) \\ d_3 &= (a_3 \cdot b_0) \oplus (a_2 \cdot b_1) \oplus (a_1 \cdot b_2) \oplus (a_0 \cdot b_3) \end{aligned}$$

This can be written in matrix form:

$$\begin{bmatrix} d_0 \\ d_1 \\ d_2 \\ d_3 \end{bmatrix} = \begin{bmatrix} a_0 & a_3 & a_2 & a_1 \\ a_1 & a_0 & a_3 & a_2 \\ a_2 & a_1 & a_0 & a_3 \\ a_3 & a_2 & a_1 & a_0 \end{bmatrix} \begin{bmatrix} b_0 \\ b_1 \\ b_2 \\ b_3 \end{bmatrix} \quad (6.14)$$

MixColumns Transformation

In the discussion of MixColumns, it was stated that there were two equivalent ways of defining the transformation. The first is the matrix multiplication shown in Equation (6.3), which is repeated here:

$$\begin{bmatrix} 02 & 03 & 01 & 01 \\ 01 & 02 & 03 & 01 \\ 01 & 01 & 02 & 03 \\ 03 & 01 & 01 & 02 \end{bmatrix} \begin{bmatrix} s_{0,0} & s_{0,1} & s_{0,2} & s_{0,3} \\ s_{1,0} & s_{1,1} & s_{1,2} & s_{1,3} \\ s_{2,0} & s_{2,1} & s_{2,2} & s_{2,3} \\ s_{3,0} & s_{3,1} & s_{3,2} & s_{3,3} \end{bmatrix} = \begin{bmatrix} s'_{0,0} & s'_{0,1} & s'_{0,2} & s'_{0,3} \\ s'_{1,0} & s'_{1,1} & s'_{1,2} & s'_{1,3} \\ s'_{2,0} & s'_{2,1} & s'_{2,2} & s'_{2,3} \\ s'_{3,0} & s'_{3,1} & s'_{3,2} & s'_{3,3} \end{bmatrix}$$

The second method is to treat each column of **State** as a four-term polynomial with coefficients in GF(2⁸). Each column is multiplied modulo $(x^4 + 1)$ by the fixed polynomial $a(x)$, given by

$$a(x) = \{03\}x^3 + \{01\}x^2 + \{01\}x + \{02\}$$

From Equation (6.10), we have $a_3 = \{03\}$; $a_2 = \{01\}$; $a_1 = \{01\}$; and $a_0 = \{02\}$. For the j th column of **State**, we have the polynomial $\text{col}_j(x) = s_{3,j}x^3 + s_{2,j}x^2 + s_{1,j}x + s_{0,j}$. Substituting into Equation (6.14), we can express $d(x) = a(x) \times \text{col}_j(x)$ as

$$\begin{bmatrix} d_0 \\ d_1 \\ d_2 \\ d_3 \end{bmatrix} = \begin{bmatrix} a_0 & a_3 & a_2 & a_1 \\ a_1 & a_0 & a_3 & a_2 \\ a_2 & a_1 & a_0 & a_3 \\ a_3 & a_2 & a_1 & a_0 \end{bmatrix} \begin{bmatrix} s_{0,j} \\ s_{1,j} \\ s_{2,j} \\ s_{3,j} \end{bmatrix} = \begin{bmatrix} 02 & 03 & 01 & 01 \\ 01 & 02 & 03 & 01 \\ 01 & 01 & 02 & 03 \\ 03 & 01 & 01 & 02 \end{bmatrix} \begin{bmatrix} s_{0,j} \\ s_{1,j} \\ s_{2,j} \\ s_{3,j} \end{bmatrix}$$

which is equivalent to Equation (6.3).

Multiplication by x

Consider the multiplication of a polynomial in the ring by x : $c(x) = x \oplus b(x)$. We have

$$\begin{aligned} c(x) &= x \oplus b(x) = [x \times (b_3x^3 + b_2x^2 + b_1x + b_0) \bmod (x^4 + 1)] \\ &= (b_3x^4 + b_2x^3 + b_1x^2 + b_0x) \bmod (x^4 + 1) \\ &= b_2x^3 + b_1x^2 + b_0x + b_3 \end{aligned}$$

Thus, multiplication by x corresponds to a 1-byte circular left shift of the 4 bytes in the word representing the polynomial. If we represent the polynomial as a 4-byte column vector, then we have

$$\begin{bmatrix} c_0 \\ c_1 \\ c_2 \\ c_3 \end{bmatrix} = \begin{bmatrix} 00 & 00 & 00 & 01 \\ 01 & 00 & 00 & 00 \\ 00 & 01 & 00 & 00 \\ 00 & 00 & 01 & 00 \end{bmatrix} \begin{bmatrix} b_0 \\ b_1 \\ b_2 \\ b_3 \end{bmatrix}$$

BLOCK CIPHER OPERATION

7.1 Multiple Encryption and Triple DES

- Double DES
- Triple DES with Two Keys
- Triple DES with Three Keys

7.2 Electronic Codebook

7.3 Cipher Block Chaining Mode

7.4 Cipher Feedback Mode

7.5 Output Feedback Mode

7.6 Counter Mode

7.7 XTS-AES Mode for Block-Oriented Storage Devices

- Tweakable Block Ciphers
- Storage Encryption Requirements
- Operation on a Single Block
- Operation on a Sector

7.8 Format-Preserving Encryption

- Motivation
- Difficulties in Designing an FPE
- Feistel Structure for Format-Preserving Encryption
- NIST Methods for Format-Preserving Encryption

7.9 Key Terms, Review Questions, and Problems

LEARNING OBJECTIVES

After studying this chapter, you should be able to:

- ◆ Analyze the security of multiple encryption schemes.
- ◆ Explain the meet-in-the-middle attack.
- ◆ Compare and contrast ECB, CBC, CFB, OFB, and counter modes of operation.
- ◆ Present an overview of the XTS-AES mode of operation.

This chapter continues our discussion of symmetric ciphers. We begin with the topic of multiple encryption, looking in particular at the most widely used multiple-encryption scheme: triple DES.

The chapter next turns to the subject of **block cipher modes of operation**. We find that there are a number of different ways to apply a block cipher to plaintext, each with its own advantages and particular applications.

7.1 MULTIPLE ENCRYPTION AND TRIPLE DES

Because of its vulnerability to brute-force attack, DES, once the most widely used symmetric cipher, has been largely replaced by stronger encryption schemes. Two approaches have been taken. One approach is to design a completely new algorithm that is resistant to both cryptanalytic and brute-force attacks, of which AES is a prime example. Another alternative, which preserves the existing investment in software and equipment, is to use multiple encryption with DES and multiple keys. We begin by examining the simplest example of this second alternative. We then look at the widely accepted **triple DES (3DES)** algorithm.

Double DES

The simplest form of multiple encryption has two encryption stages and two keys (Figure 7.1a). Given a plaintext P and two encryption keys K_1 and K_2 , ciphertext C is generated as

$$C = E(K_2, E(K_1, P))$$

Decryption requires that the keys be applied in reverse order:

$$P = D(K_1, D(K_2, C))$$

For DES, this scheme appears to involve a key length of $56 \times 2 = 112$ bits, and should result in a dramatic increase in cryptographic strength. But we need to examine the algorithm more closely.

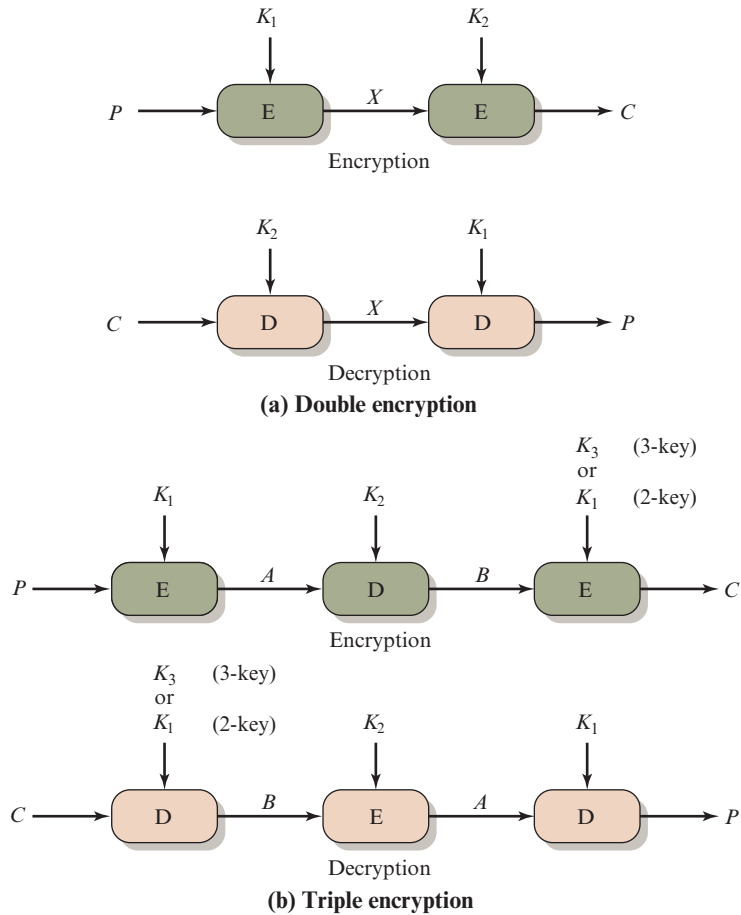

Figure 7.1 Multiple Encryption

REDUCTION TO A SINGLE STAGE Suppose it were true for DES, for all 56-bit key values, that given any two keys K_1 and K_2 , it would be possible to find a key K_3 such that

$$E(K_2, E(K_1, P)) = E(K_3, P) \quad (7.1)$$

If this were the case, then double encryption, and indeed any number of stages of multiple encryption with DES, would be useless because the result would be equivalent to a single encryption with a single 56-bit key.

On the face of it, it does not appear that Equation (7.1) is likely to hold. Consider that encryption with DES is a mapping of 64-bit blocks to 64-bit blocks. In fact, the mapping can be viewed as a permutation. That is, if we consider all 2^{64} possible input blocks, DES encryption with a specific key will map each block into a unique 64-bit block. Otherwise, if, say, two given input blocks mapped to the same output block, then decryption to recover the original plaintext would be impossible.

With 2^{64} possible inputs, how many different mappings are there that generate a permutation of the input blocks? The value is easily seen to be

$$(2^{64})! = 10^{34738000000000000000} > (10^{10^{20}})$$

On the other hand, DES defines one mapping for each different key, for a total number of mappings:

$$2^{56} < 10^{17}$$

Therefore, it is reasonable to assume that if DES is used twice with different keys, it will produce one of the many mappings that are not defined by a single application of DES. Although there was much supporting evidence for this assumption, it was not until 1992 that the assumption was proven [CAMP92].

MEET-IN-THE-MIDDLE ATTACK Thus, the use of double DES results in a mapping that is not equivalent to a single DES encryption. But there is a way to attack this scheme, one that does not depend on any particular property of DES but that will work against any block encryption cipher.

The algorithm, known as a **meet-in-the-middle attack**, was first described in [DIFF77]. It is based on the observation that, if we have

$$C = E(K_2, E(K_1, P))$$

then (see Figure 7.1a)

$$X = E(K_1, P) = D(K_2, C)$$

Given a known pair, (P, C) , the attack proceeds as follows. First, encrypt P for all 2^{56} possible values of K_1 . Store these results in a table and then sort the table by the values of X . Next, decrypt C using all 2^{56} possible values of K_2 . As each decryption is produced, check the result against the table for a match. If a match occurs, then test the two resulting keys against a new known plaintext–ciphertext pair. If the two keys produce the correct ciphertext, accept them as the correct keys.

For any given plaintext P , there are 2^{64} possible ciphertext values that could be produced by double DES. Double DES uses, in effect, a 112-bit key, so that there are 2^{112} possible keys. Therefore, for a given plaintext P , the maximum number of different 112-bit keys that could produce a given ciphertext C is $2^{112}/2^{64} = 2^{48}$. Thus, the foregoing procedure can produce about 2^{48} false alarms on the first (P, C) pair. A similar argument indicates that with an additional 64 bits of known plaintext and ciphertext, the false alarm rate is reduced to $2^{48-64} = 2^{-16}$. Put another way, if the meet-in-the-middle attack is performed on two blocks of known plaintext–ciphertext, the probability that the correct keys are determined is $1 - 2^{-16}$. The result is that a known plaintext attack will succeed against double DES, which has a key size of 112 bits, with an effort on the order of 2^{56} , which is not much more than the 2^{55} required for single DES.

Triple DES with Two Keys

An obvious counter to the meet-in-the-middle attack is to use three stages of encryption with three different keys. Using DES as the underlying algorithm, this approach is commonly referred to as 3DES, or Triple Data Encryption

Algorithm (TDEA). As shown in Figure 7.1b, there are two versions of 3DES; one using two keys and one using three keys. NIST SP 800-67 (*Recommendation for the Triple Data Encryption Block Cipher*, January 2012) defines the two-key and three-key versions. We look first at the strength of the two-key version and then examine the three-key version.

Two-key triple encryption was first proposed by Tuchman [TUCH79]. The function follows an encrypt-decrypt-encrypt (EDE) sequence (Figure 7.1b):

$$\begin{aligned}C &= E(K_1, D(K_2, E(K_1, P))) \\P &= D(K_1, E(K_2, D(K_1, C)))\end{aligned}$$

There is no cryptographic significance to the use of decryption for the second stage. Its only advantage is that it allows users of 3DES to decrypt data encrypted by users of the older single DES:

$$\begin{aligned}C &= E(K_1, D(K_1, E(K_1, P))) = E(K_1, P) \\P &= D(K_1, E(K_1, D(K_1, C))) = D(K_1, C)\end{aligned}$$

3DES with two keys is a relatively popular alternative to DES and has been adopted for use in the key management standards ANSI X9.17 and ISO 8732.¹

Currently, there are no practical cryptanalytic attacks on 3DES. Coppersmith [COPP94] notes that the cost of a brute-force key search on 3DES is on the order of $2^{112} \approx (5 \times 10^{33})$ and estimates that the cost of differential cryptanalysis suffers an exponential growth, compared to single DES, exceeding 10^{52} .

It is worth looking at several proposed attacks on 3DES that, although not practical, give a flavor for the types of attacks that have been considered and that could form the basis for more successful future attacks.

The first serious proposal came from Merkle and Hellman [MERK81]. Their plan involves finding plaintext values that produce a first intermediate value of $A = 0$ (Figure 7.1b) and then using the meet-in-the-middle attack to determine the two keys. The level of effort is 2^{56} , but the technique requires 2^{56} chosen plaintext–ciphertext pairs, which is a number unlikely to be provided by the holder of the keys.

A known-plaintext attack is outlined in [VANO90]. This method is an improvement over the chosen-plaintext approach but requires more effort. The attack is based on the observation that if we know A and C (Figure 7.1b), then the problem reduces to that of an attack on double DES. Of course, the attacker does not know A , even if P and C are known, as long as the two keys are unknown. However, the attacker can choose a potential value of A and then try to find a known (P, C) pair that produces A . The attack proceeds as follows.

1. Obtain n (P, C) pairs. This is the known plaintext. Place these in a table (Table 1) sorted on the values of P (Figure 7.2b).

¹American National Standards Institute (ANSI): *Financial Institution Key Management (Wholesale)*. From its title, X9.17 appears to be a somewhat obscure standard. Yet a number of techniques specified in this standard have been adopted for use in other standards and applications, as we shall see throughout this book.

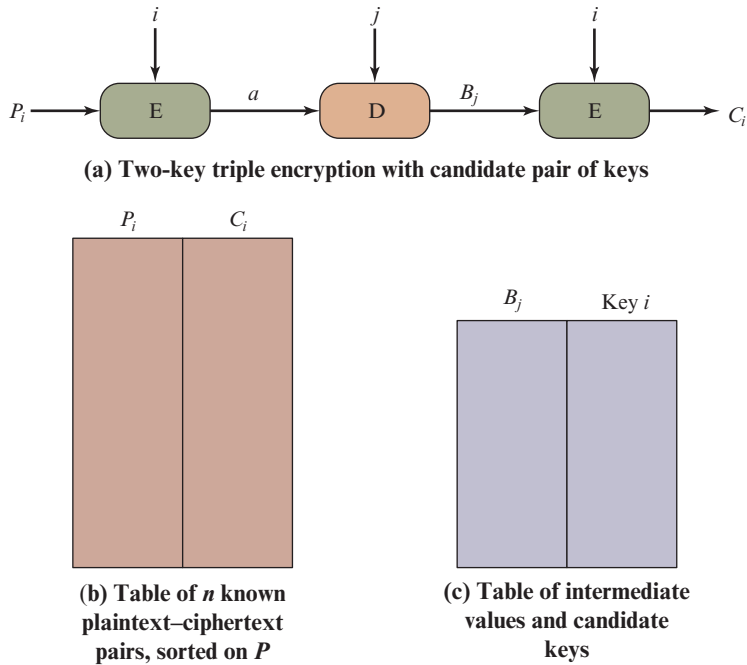

Figure 7.2 Known-Plaintext Attack on Triple DES

2. Pick an arbitrary value a for A , and create a second table (Figure 7.2c) with entries defined in the following fashion. For each of the 2^{56} possible keys $K_1 = i$, calculate the plaintext value P_i such that

$$P_i = D(i, a)$$

For each P_i that matches an entry in Table 1, create an entry in Table 2 consisting of the K_1 value and the value of B that is produced for the (P, C) pair from Table 1, assuming that value of K_1 :

$$B = D(i, C)$$

At the end of this step, sort Table 2 on the values of B .

3. We now have a number of candidate values of K_1 in Table 2 and are in a position to search for a value of K_2 . For each of the 2^{56} possible keys $K_2 = j$, calculate the second intermediate value for our chosen value of a :

$$B_j = D(j, a)$$

At each step, look up B_j in Table 2. If there is a match, then the corresponding key i from Table 2 plus this value of j are candidate values for the unknown keys (K_1, K_2) . Why? Because we have found a pair of keys (i, j) that produce a known (P, C) pair (Figure 7.2a).

4. Test each candidate pair of keys (i, j) on a few other plaintext-ciphertext pairs. If a pair of keys produces the desired ciphertext, the task is complete. If no pair succeeds, repeat from step 1 with a new value of a .

For a given known (P, C) , the probability of selecting the unique value of a that leads to success is $1/2^{64}$. Thus, given n (P, C) pairs, the probability of success for a single selected value of a is $n/2^{64}$. A basic result from probability theory is that the expected number of draws required to draw one red ball out of a bin containing n red balls and $N - n$ green balls is $(N + 1)/(n + 1)$ if the balls are not replaced. So the expected number of values of a that must be tried is, for large n ,

$$\frac{2^{64} + 1}{n + 1} \approx \frac{2^{64}}{n}$$

Thus, the expected running time of the attack is on the order of

$$(2^{56}) \frac{2^{64}}{n} = 2^{120 - \log_2 n}$$

Triple DES with Three Keys

Although the attacks just described appear impractical, anyone using two-key 3DES may feel some concern. Thus, many researchers now feel that three-key 3DES is the preferred alternative (e.g., [KALI96a]). In SP 800-57, Part 1 (*Recommendation for Key Management—Part 1: General*, July 2012) NIST recommends that 2-key 3DES be retired as soon as practical and replaced with 3-key 3DES.

Three-key 3DES is defined as

$$C = E(K_3, D(K_2, E(K_1, P)))$$

Backward compatibility with DES is provided by putting $K_3 = K_2$ or $K_1 = K_2$. One might expect that 3TDEA would provide $56 \cdot 3 = 168$ bits of strength. However, there is an attack on 3TDEA that reduces the strength to the work that would be involved in exhausting a 112-bit key [MERK81].

A number of Internet-based applications have adopted three-key 3DES, including PGP and S/MIME, both discussed in Chapter 21.

7.2 ELECTRONIC CODEBOOK

A block cipher takes a fixed-length block of text of length b bits and a key as input and produces a b -bit block of ciphertext. If the amount of plaintext to be encrypted is greater than b bits, then the block cipher can still be used by breaking the plaintext up into b -bit blocks. When multiple blocks of plaintext are encrypted using the same key, a number of security issues arise. To apply a block cipher in a variety of applications, five *modes of operation* have been defined by NIST (SP 800-38A). In essence, a mode of operation is a technique for enhancing the effect of a cryptographic algorithm or adapting the algorithm for an application, such as applying a block cipher to a sequence of data blocks or a data stream. The five modes are intended to cover a wide variety of applications of encryption for which a block cipher could be used. These modes are intended for use with any symmetric block cipher, including triple DES and AES. The modes are summarized in Table 7.1 and described in this and the following sections.

Table 7.1 Block Cipher Modes of Operation

Mode	Description	Typical Application
Electronic Codebook (ECB)	Each block of plaintext bits is encoded independently using the same key.	<ul style="list-style-type: none"> Secure transmission of single values (e.g., an encryption key)
Cipher Block Chaining (CBC)	The input to the encryption algorithm is the XOR of the next block of plaintext and the preceding block of ciphertext.	<ul style="list-style-type: none"> General-purpose block-oriented transmission Authentication
Cipher Feedback (CFB)	Input is processed s bits at a time. Preceding ciphertext is used as input to the encryption algorithm to produce pseudorandom output, which is XORed with plaintext to produce next unit of ciphertext.	<ul style="list-style-type: none"> General-purpose stream-oriented transmission Authentication
Output Feedback (OFB)	Similar to CFB, except that the input to the encryption algorithm is the preceding encryption output, and full blocks are used.	<ul style="list-style-type: none"> Stream-oriented transmission over noisy channel (e.g., satellite communication)
Counter (CTR)	Each block of plaintext is XORed with an encrypted counter. The counter is incremented for each subsequent block.	<ul style="list-style-type: none"> General-purpose block-oriented transmission Useful for high-speed requirements

The simplest mode is the electronic codebook (ECB) mode, in which plaintext is handled one block at a time and each block of plaintext is encrypted using the same key (Figure 7.3). The term *codebook* is used because, for a given key, there is a unique ciphertext for every b -bit block of plaintext. Therefore, we can imagine a gigantic codebook in which there is an entry for every possible b -bit plaintext pattern showing its corresponding ciphertext.

For a message longer than b bits, the procedure is simply to break the message into b -bit blocks, padding the last block if necessary. Decryption is performed one block at a time, always using the same key. In Figure 7.3, the plaintext (padded as necessary) consists of a sequence of b -bit blocks, P_1, P_2, \dots, P_N ; the corresponding sequence of ciphertext blocks is C_1, C_2, \dots, C_N . We can define ECB mode as follows.

ECB	$C_j = E(K, P_j) \quad j = 1, \dots, N$	$P_j = D(K, C_j) \quad j = 1, \dots, N$
-----	---	---

The ECB mode should be used only to secure messages shorter than a single block of underlying cipher (i.e., 64 bits for 3DES and 128 bits for AES), such as to encrypt a secret key. Because in most of the cases messages are longer than the encryption block mode, this mode has a minimum practical value.

The most significant characteristic of ECB is that if the same b -bit block of plaintext appears more than once in the message, it always produces the same ciphertext.

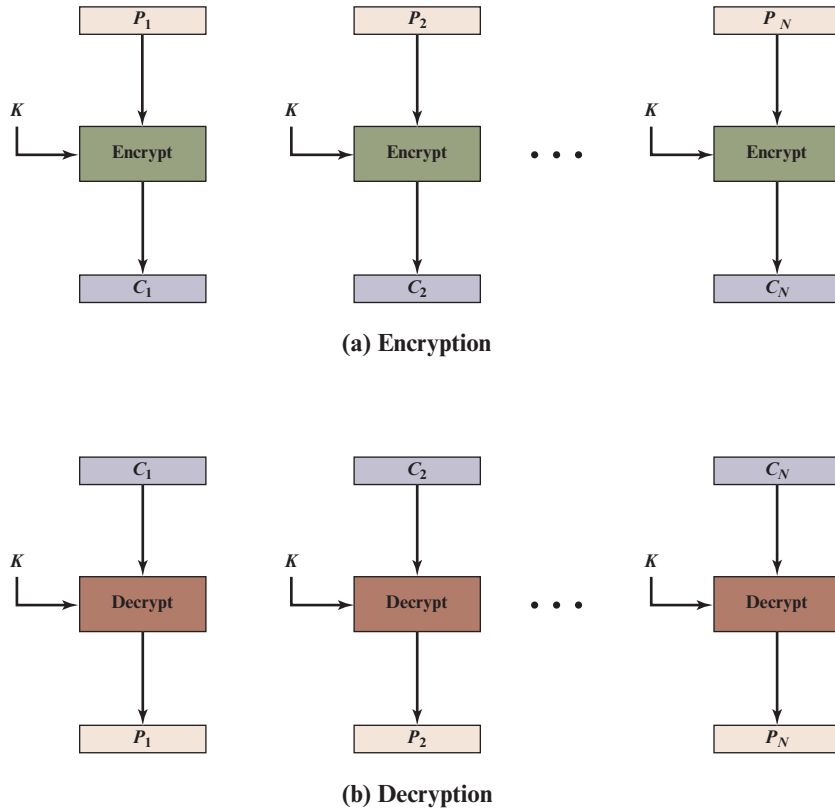

Figure 7.3 Electronic Codebook (ECB) Mode

For lengthy messages, the ECB mode may not be secure. If the message is highly structured, it may be possible for a cryptanalyst to exploit these regularities. For example, if it is known that the message always starts out with certain predefined fields, then the cryptanalyst may have a number of known plaintext–ciphertext pairs to work with. If the message has repetitive elements with a period of repetition a multiple of b bits, then these elements can be identified by the analyst. This may help in the analysis or may provide an opportunity for substituting or rearranging blocks.

We now turn to more complex modes of operation. [KNUD00] lists the following criteria and properties for evaluating and constructing block cipher modes of operation that are superior to ECB:

- **Overhead:** The additional operations for the encryption and decryption operation when compared to encrypting and decrypting in the ECB mode.
- **Error recovery:** The property that an error in the i th ciphertext block is inherited by only a few plaintext blocks after which the mode resynchronizes.
- **Error propagation:** The property that an error in the i th ciphertext block is inherited by the i th and all subsequent plaintext blocks. What is meant here is a bit error that occurs in the transmission of a ciphertext block, not a computational error in the encryption of a plaintext block.

- **Diffusion:** How the plaintext statistics are reflected in the ciphertext. Low entropy plaintext blocks should not be reflected in the ciphertext blocks. Roughly, low entropy equates to predictability or lack of randomness (see Appendix B).
- **Security:** Whether or not the ciphertext blocks leak information about the plaintext blocks.

7.3 CIPHER BLOCK CHAINING MODE

To overcome the security deficiencies of ECB, we would like a technique in which the same plaintext block, if repeated, produces different ciphertext blocks. A simple way to satisfy this requirement is the cipher block chaining (CBC) mode (Figure 7.4). In this scheme, the input to the encryption algorithm is the XOR of the current plaintext block and the preceding ciphertext block; the same key is used for each block. In effect, we have chained together the processing of the sequence of plaintext blocks. The input to the encryption function for each plaintext block bears no fixed relationship to the plaintext block. Therefore, repeating patterns of b bits are not exposed. As with the ECB mode, the CBC mode requires that the last block be padded to a full b bits if it is a partial block.

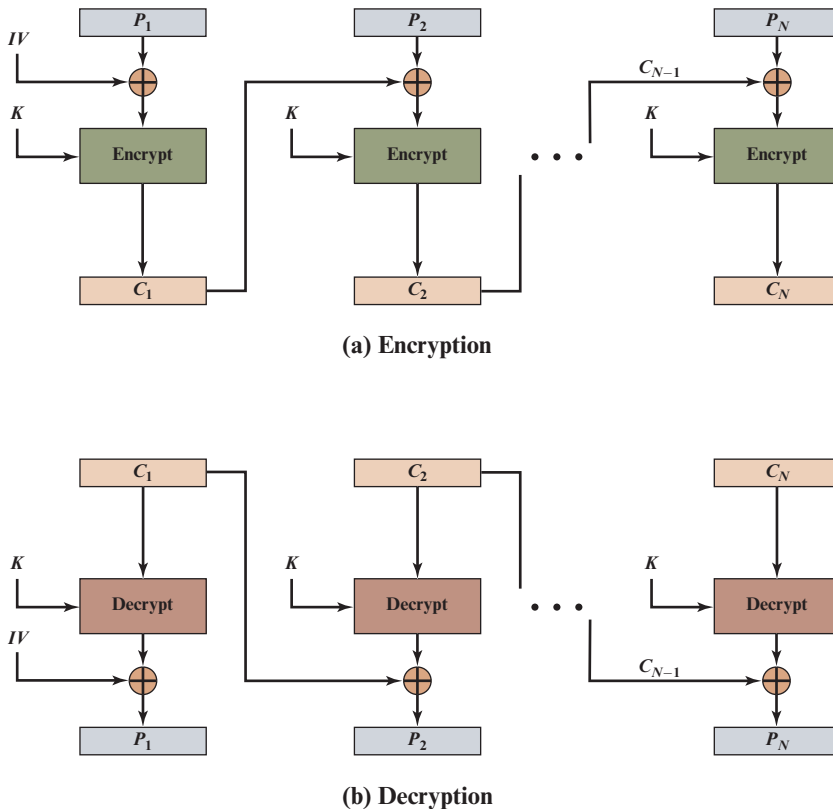

Figure 7.4 Cipher Block Chaining (CBC) Mode

For decryption, each cipher block is passed through the decryption algorithm. The result is XORed with the preceding ciphertext block to produce the plaintext block. To see that this works, we can write

$$C_j = E(K, [C_{j-1} \oplus P_j])$$

Then

$$\begin{aligned} D(K, C_j) &= D(K, E(K, [C_{j-1} \oplus P_j])) \\ D(K, C_j) &= C_{j-1} \oplus P_j \\ C_{j-1} \oplus D(K, C_j) &= C_{j-1} \oplus C_{j-1} \oplus P_j = P_j \end{aligned}$$

To produce the first block of ciphertext, an initialization vector (IV) is XORed with the first block of plaintext. On decryption, the IV is XORed with the output of the decryption algorithm to recover the first block of plaintext. The IV is a data block that is the same size as the cipher block. We can define CBC mode as

CBC	$C_1 = E(K, [P_1 \oplus \text{IV}])$	$P_1 = D(K, C_1) \oplus \text{IV}$
	$C_j = E(K, [P_j \oplus C_{j-1}]) j = 2, \dots, N$	$P_j = D(K, C_j) \oplus C_{j-1} j = 2, \dots, N$

The IV must be known to both the sender and receiver but be unpredictable by a third party. In particular, for any given plaintext, it must not be possible to predict the IV that will be associated to the plaintext in advance of the generation of the IV. For maximum security, the IV should be protected against unauthorized changes. This could be done by sending the IV using ECB encryption. One reason for protecting the IV is as follows: If an opponent is able to fool the receiver into using a different value for IV, then the opponent is able to invert selected bits in the first block of plaintext. To see this, consider

$$\begin{aligned} C_1 &= E(K, [\text{IV} \oplus P_1]) \\ P_1 &= \text{IV} \oplus D(K, C_1) \end{aligned}$$

Now use the notation that $X[i]$ denotes the i th bit of the b -bit quantity X . Then

$$P_1[i] = \text{IV}[i] \oplus D(K, C_1)[i]$$

Then, using the properties of XOR, we can state

$$P_1[i]' = \text{IV}[i]' \oplus D(K, C_1)[i]$$

where the prime notation denotes bit complementation. This means that if an opponent can predictably change bits in IV, the corresponding bits of the received value of P_1 can be changed.

For other possible attacks based on prior knowledge of IV, see [VOYD83].

So long as it is unpredictable, the specific choice of IV is unimportant. SP 800-38A recommends two possible methods: The first method is to apply the encryption function, under the same key that is used for the encryption of the plaintext, to a **nonce**.² The nonce must be a data block that is unique to each execution of

²NIST SP 800-90 (*Recommendation for Random Number Generation Using Deterministic Random Bit Generators*) defines nonce as follows: A time-varying value that has at most a negligible chance of repeating, for example, a random value that is generated anew for each use, a timestamp, a sequence number, or some combination of these.

the encryption operation. For example, the nonce may be a counter, a timestamp, or a message number. The second method is to generate a random data block using a random number generator.

In conclusion, because of the chaining mechanism of CBC, it is an appropriate mode for encrypting messages of length greater than b bits.

In addition to its use to achieve confidentiality, the CBC mode can be used for authentication. This use is described in Chapter 12.

7.4 CIPHER FEEDBACK MODE

For AES, DES, or any block cipher, encryption is performed on a block of b bits. In the case of DES, $b = 64$ and in the case of AES, $b = 128$. However, it is possible to convert a block cipher into a stream cipher, using one of the three modes to be discussed in this and the next two sections: cipher feedback (CFB) mode, output feedback (OFB) mode, and counter (CTR) mode. A stream cipher eliminates the need to pad a message to be an integral number of blocks. It also can operate in real time. Thus, if a character stream is being transmitted, each character can be encrypted and transmitted immediately using a character-oriented stream cipher.

One desirable property of a stream cipher is that the ciphertext be of the same length as the plaintext. Thus, if 8-bit characters are being transmitted, each character should be encrypted to produce a ciphertext output of 8 bits. If more than 8 bits are produced, transmission capacity is wasted.

Figure 7.5 depicts the CFB scheme. In the figure, it is assumed that the unit of transmission is s bits; a common value is $s = 8$. As with CBC, the units of plaintext are chained together, so that the ciphertext of any plaintext unit is a function of all the preceding plaintext. In this case, rather than blocks of b bits, the plaintext is divided into *segments* of s bits.

First, consider encryption. The input to the encryption function is a b -bit shift register that is initially set to some initialization vector (IV). The leftmost (most significant) s bits of the output of the encryption function are XORed with the first segment of plaintext P_1 to produce the first unit of ciphertext C_1 , which is then transmitted. In addition, the contents of the shift register are shifted left by s bits, and C_1 is placed in the rightmost (least significant) s bits of the shift register. This process continues until all plaintext units have been encrypted.

For decryption, the same scheme is used, except that the received ciphertext unit is XORed with the output of the encryption function to produce the plaintext unit. Note that it is the *encryption* function that is used, not the decryption function. This is easily explained. Let $\text{MSB}_s(X)$ be defined as the most significant s bits of X . Then

$$C_1 = P_1 \oplus \text{MSB}_s[\text{E}(K, \text{IV})]$$

Therefore, by rearranging terms:

$$P_1 = C_1 \oplus \text{MSB}_s[\text{E}(K, \text{IV})]$$

The same reasoning holds for subsequent steps in the process.

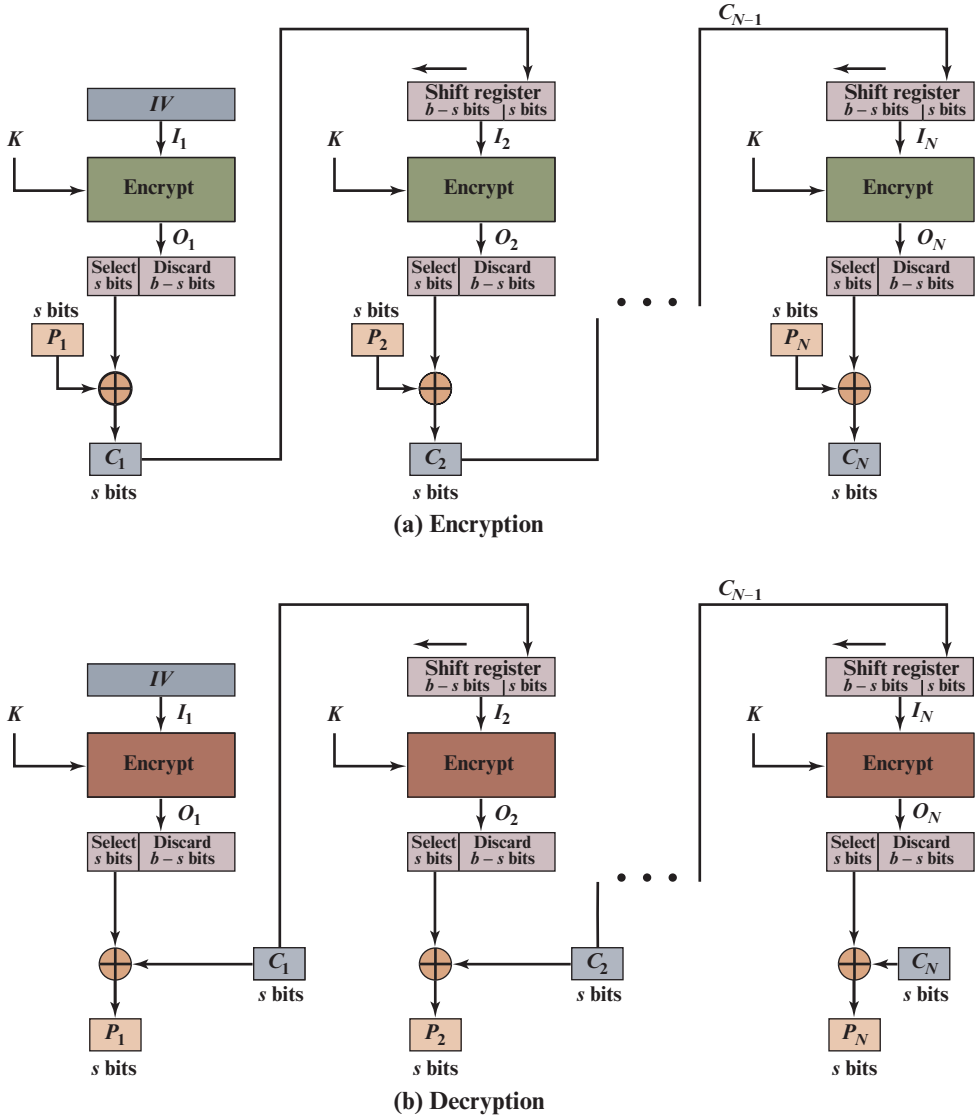

Figure 7.5 s-bit Cipher Feedback (CFB) Mode

We can define CFB mode as follows.

CFB	$I_1 = IV$	$I_1 = IV$
	$I_j = \text{LSB}_{b-s}(I_{j-1}) \parallel C_{j-1} \quad j = 2, \dots, N$	$I_j = \text{LSB}_{b-s}(I_{j-1}) \parallel C_{j-1} \quad j = 2, \dots, N$
	$O_j = E(K, I_j) \quad j = 1, \dots, N$	$O_j = E(K, I_j) \quad j = 1, \dots, N$
	$C_j = P_j \oplus \text{MSB}_s(O_j) \quad j = 1, \dots, N$	$P_j = C_j \oplus \text{MSB}_s(O_j) \quad j = 1, \dots, N$

Although CFB can be viewed as a stream cipher, it does not conform to the typical construction of a stream cipher. In a typical stream cipher, the cipher takes

as input some initial value and a key and generates a stream of bits, which is then XORed with the plaintext bits (see Figure 4.1). In the case of CFB, the stream of bits that is XORed with the plaintext also depends on the plaintext.

In CFB encryption, like CBC encryption, the input block to each forward cipher function (except the first) depends on the result of the previous forward cipher function; therefore, multiple forward cipher operations cannot be performed in parallel. In CFB decryption, the required forward cipher operations can be performed in parallel if the input blocks are first constructed (in series) from the IV and the ciphertext.

7.5 OUTPUT FEEDBACK MODE

The **output feedback (OFB) mode** is similar in structure to that of CFB. For OFB, the output of the encryption function is fed back to become the input for encrypting the next block of plaintext (Figure 7.6). In CFB, the output of the XOR unit is fed back to become input for encrypting the next block. The other difference is that the OFB mode operates on full blocks of plaintext and ciphertext, whereas CFB operates on an s -bit subset. OFB encryption can be expressed as

$$C_j = P_j \oplus E(K, O_{j-1})$$

where

$$O_{j-1} = E(K, O_{j-2})$$

Some thought should convince you that we can rewrite the encryption expression as:

$$C_j = P_j \oplus E(K, [C_{j-1} \oplus P_{j-1}])$$

By rearranging terms, we can demonstrate that decryption works.

$$P_j = C_j \oplus E(K, [C_{j-1} \oplus P_{j-1}])$$

We can define OFB mode as follows.

OFB	$I_1 = \text{Nonce}$	$I_1 = \text{Nonce}$
	$I_j = O_{j-1} \quad j = 2, \dots, N$	$I_j = O_{j-1} \quad j = 2, \dots, N$
	$O_j = E(K, I_j) \quad j = 1, \dots, N$	$O_j = E(K, I_j) \quad j = 1, \dots, N$
	$C_j = P_j \oplus O_j \quad j = 1, \dots, N - 1$	$P_j = C_j \oplus O_j \quad j = 1, \dots, N - 1$
	$C_N^* = P_N^* \oplus \text{MSB}_u(O_N)$	$P_N^* = C_N^* \oplus \text{MSB}_u(O_N)$

Let the size of a block be b . If the last block of plaintext contains u bits (indicated by *), with $u < b$, the most significant u bits of the last output block O_N are used for the XOR operation; the remaining $b - u$ bits of the last output block are discarded.

As with CBC and CFB, the OFB mode requires an initialization vector. In the case of OFB, the IV must be a nonce; that is, the IV must be unique to each execution of the encryption operation. The reason for this is that the sequence of

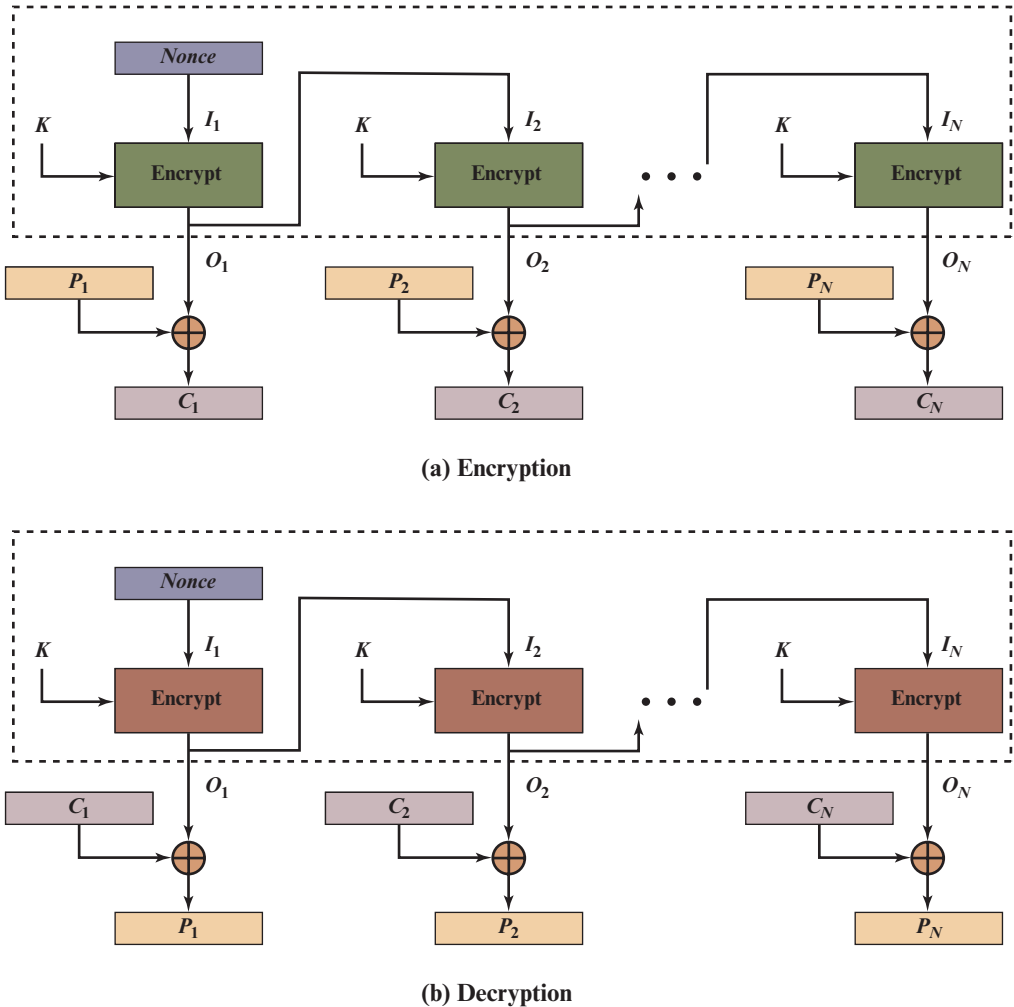

Figure 7.6 Output Feedback (OFB) Mode

encryption output blocks, O_i , depends only on the key and the IV and does not depend on the plaintext. Therefore, for a given key and IV, the stream of output bits used to XOR with the stream of plaintext bits is fixed. If two different messages had an identical block of plaintext in the identical position, then an attacker would be able to determine that portion of the O_i stream.

One advantage of the OFB method is that bit errors in transmission do not propagate. For example, if a bit error occurs in C_1 , only the recovered value of P_1 is affected; subsequent plaintext units are not corrupted. With CFB, C_1 also serves as input to the shift register and therefore causes additional corruption downstream.

The disadvantage of OFB is that it is more vulnerable to a message stream modification attack than is CFB. Consider that complementing a bit in the ciphertext complements the corresponding bit in the recovered plaintext. Thus, controlled

changes to the recovered plaintext can be made. This may make it possible for an opponent, by making the necessary changes to the checksum portion of the message as well as to the data portion, to alter the ciphertext in such a way that it is not detected by an error-correcting code. For a further discussion, see [VOYD83].

OFB has the structure of a typical stream cipher, because the cipher generates a stream of bits as a function of an initial value and a key, and that stream of bits is XORed with the plaintext bits (see Figure 4.1). The generated stream that is XORed with the plaintext is itself independent of the plaintext; this is highlighted by dashed boxes in Figure 7.6. One distinction from the stream ciphers we discuss in Chapter 8 is that OFB encrypts plaintext a full block at a time, where typically a block is 64 or 128 bits. Many stream ciphers encrypt one byte at a time.

7.6 COUNTER MODE

Although interest in the **counter (CTR) mode** has increased recently with applications to ATM (asynchronous transfer mode) network security and IPsec (IP security), this mode was proposed in 1979 (e.g., [DIFF79]).

Figure 7.7 depicts the CTR mode. A counter equal to the plaintext block size is used. The only requirement stated in SP 800-38A is that the counter value must be different for each plaintext block that is encrypted. Typically, the counter is initialized to some value and then incremented by 1 for each subsequent block (modulo 2^b , where b is the block size). For encryption, the counter is encrypted and then XORed with the plaintext block to produce the ciphertext block; there is no chaining. For decryption, the same sequence of counter values is used, with each encrypted counter XORed with a ciphertext block to recover the corresponding plaintext block. Thus, the initial counter value must be made available for decryption. Given a sequence of counters T_1, T_2, \dots, T_N , we can define CTR mode as follows.

CTR	$C_j = P_j \oplus E(K, T_j) \quad j = 1, \dots, N - 1$	$P_j = C_j \oplus E(K, T_j) \quad j = 1, \dots, N - 1$
	$C_N^* = P_N^* \oplus \text{MSB}_u[E(K, T_N)]$	$P_N^* = C_N^* \oplus \text{MSB}_u[E(K, T_N)]$

For the last plaintext block, which may be a partial block of u bits, the most significant u bits of the last output block are used for the XOR operation; the remaining $b - u$ bits are discarded. Unlike the ECB, CBC, and CFB modes, we do not need to use padding because of the structure of the CTR mode.

As with the OFB mode, the initial counter value must be a nonce; that is, T_1 must be different for all of the messages encrypted using the same key. Further, all T_i values across all messages must be unique. If, contrary to this requirement, a counter value is used multiple times, then the confidentiality of all of the plaintext blocks corresponding to that counter value may be compromised. In particular, if any plaintext block that is encrypted using a given counter value is known, then the output of the encryption function can be determined easily from the associated ciphertext block. This output allows any other plaintext blocks that are encrypted using the same counter value to be easily recovered from their associated ciphertext blocks.

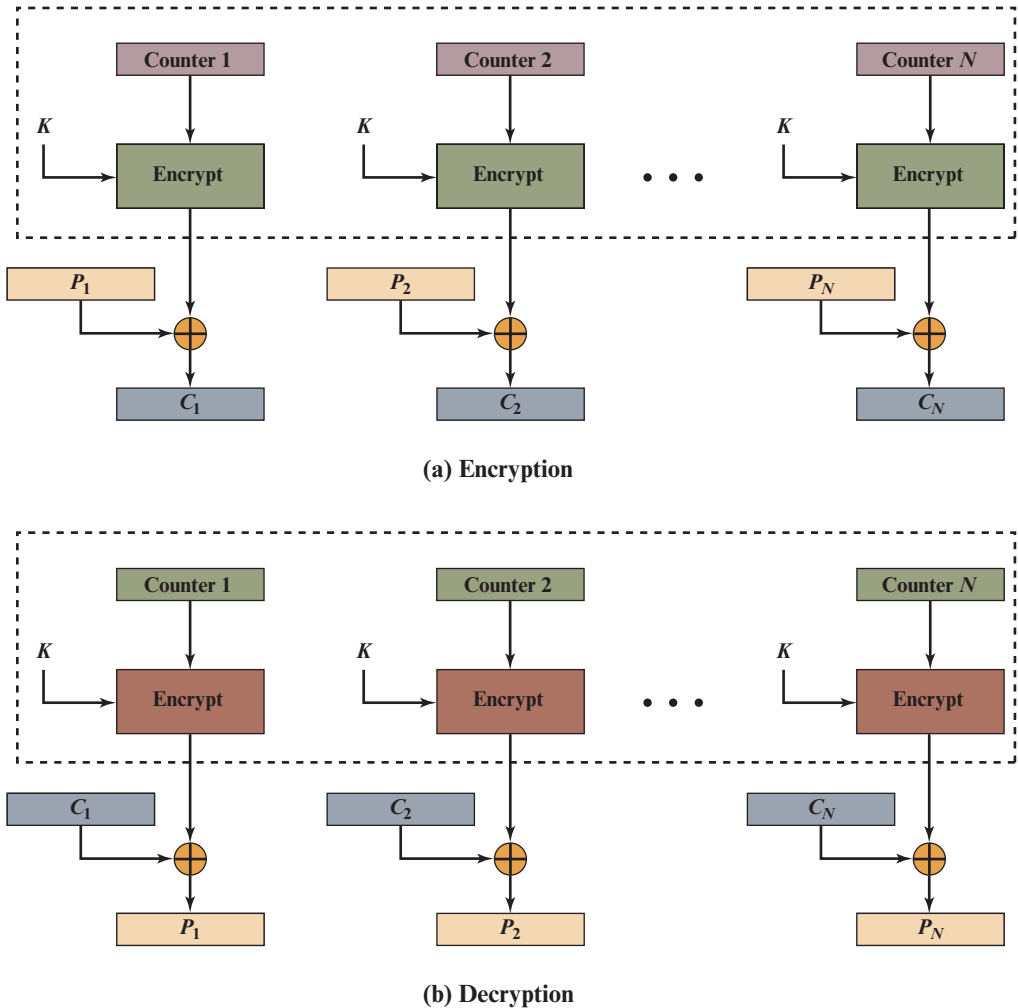

Figure 7.7 Counter (CTR) Mode

One way to ensure the uniqueness of counter values is to continue to increment the counter value by 1 across messages. That is, the first counter value of the each message is one more than the last counter value of the preceding message.

[LIPM00] lists the following advantages of CTR mode.

- Hardware efficiency:** Unlike the three chaining modes, encryption (or decryption) in CTR mode can be done in parallel on multiple blocks of plaintext or ciphertext. For the chaining modes, the algorithm must complete the computation on one block before beginning on the next block. This limits the maximum throughput of the algorithm to the reciprocal of the time for one execution of block encryption or decryption. In CTR mode, the throughput is only limited by the amount of parallelism that is achieved.

- **Software efficiency:** Similarly, because of the opportunities for parallel execution in CTR mode, processors that support parallel features, such as aggressive pipelining, multiple instruction dispatch per clock cycle, a large number of registers, and SIMD instructions, can be effectively utilized.
- **Preprocessing:** The execution of the underlying encryption algorithm does not depend on input of the plaintext or ciphertext. Therefore, if sufficient memory is available and security is maintained, preprocessing can be used to prepare the output of the encryption boxes that feed into the XOR functions, as in Figure 7.7. When the plaintext or ciphertext input is presented, then the only computation is a series of XORs. Such a strategy greatly enhances throughput.
- **Random access:** The i th block of plaintext or ciphertext can be processed in random-access fashion. With the chaining modes, block C_i cannot be computed until the $i - 1$ prior blocks are computed. There may be applications in which a ciphertext is stored and it is desired to decrypt just one block; for such applications, the random access feature is attractive.
- **Provable security:** It can be shown that CTR is at least as secure as the other modes discussed in this chapter.
- **Simplicity:** Unlike ECB and CBC modes, CTR mode requires only the implementation of the encryption algorithm and not the decryption algorithm. This matters most when the decryption algorithm differs substantially from the encryption algorithm, as it does for AES. In addition, the decryption key scheduling need not be implemented.

Note that, with the exception of ECB, all of the NIST-approved block cipher modes of operation involve feedback. This is clearly seen in Figure 7.8. To highlight the feedback mechanism, it is useful to think of the encryption function as taking input from an input register whose length equals the encryption block length and with output stored in an output register. The input register is updated one block at a time by the feedback mechanism. After each update, the encryption algorithm is executed, producing a result in the output register. Meanwhile, a block of plaintext is accessed. Note that both OFB and CTR produce output that is independent of both the plaintext and the ciphertext. Thus, they are natural candidates for stream ciphers that encrypt plaintext by XOR one full block at a time.

7.7 XTS-AES MODE FOR BLOCK-ORIENTED STORAGE DEVICES

In 2010, NIST approved an additional block cipher mode of operation, XTS-AES. This mode is also an IEEE standard, IEEE Std 1619-2007, which was developed by the IEEE Security in Storage Working Group (P1619). The standard describes a method of encryption for data stored in sector-based devices where the threat model includes possible access to stored data by the adversary. The standard has received widespread industry support.

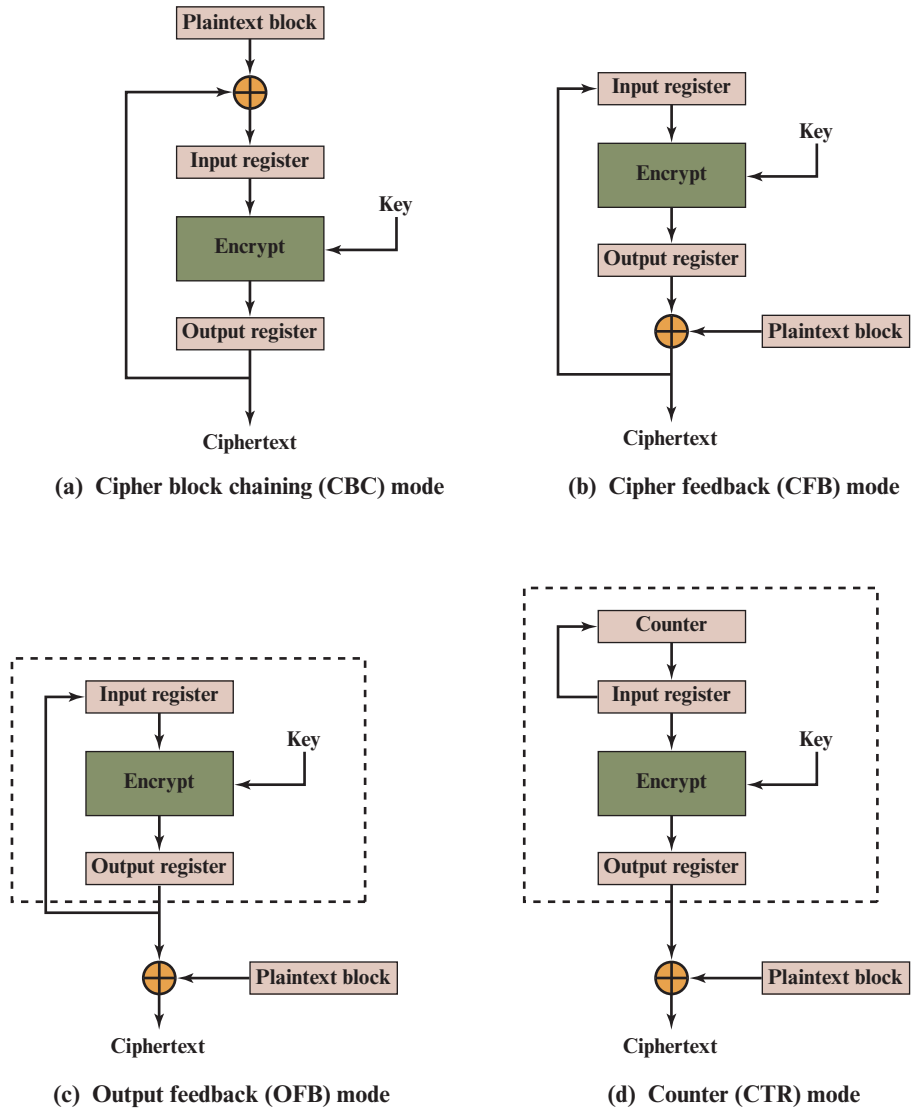

Figure 7.8 Feedback Characteristic of Modes of Operation

Tweakable Block Ciphers

The XTS-AES mode is based on the concept of a **tweakable block cipher**, introduced in [LISK02]. The form of this concept used in XTS-AES was first described in [ROGA04a].

Before examining XTS-AES, let us consider the general structure of a tweakable block cipher. A tweakable block cipher is one that has three inputs: a plaintext P , a symmetric key K , and a tweak T ; and produces a ciphertext output C . We can write this as $C = E(K, T, P)$. The tweak need not be kept secret. Whereas the purpose of the key is to provide security, the purpose of the tweak is to provide

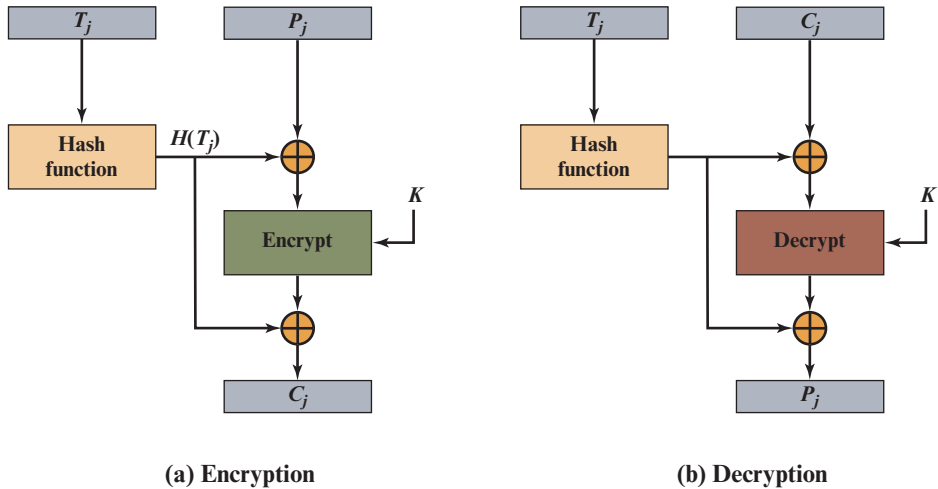

Figure 7.9 Tweakable Block Cipher

variability. That is, the use of different tweaks with the same plaintext and same key produces different outputs. The basic structure of several tweakable block ciphers that have been implemented is shown in Figure 7.9. Encryption can be expressed as:

$$C = H(T) \oplus E(K, H(T) \oplus P)$$

where H is a hash function. For decryption, the same structure is used with the plaintext as input and decryption as the function instead of encryption. To see that this works, we can write

$$H(T) \oplus C = E(K, H(T) \oplus P)$$

$$D[K, H(T) \oplus C] = H(T) \oplus P$$

$$H(T) \oplus D(K, H(T) \oplus C) = P$$

It is now easy to construct a block cipher mode of operation by using a different tweak value on each block. In essence, the ECB mode is used but for each block the tweak is changed. This overcomes the principal security weakness of ECB, which is that two encryptions of the same block yield the same ciphertext.

Storage Encryption Requirements

The requirements for encrypting stored data, also referred to as “data at rest” differ somewhat from those for transmitted data. The P1619 standard was designed to have the following characteristics:

1. The ciphertext is freely available for an attacker. Among the circumstances that lead to this situation:
 - a. A group of users has authorized access to a database. Some of the records in the database are encrypted so that only specific users can successfully read/

write them. Other users can retrieve an encrypted record but are unable to read it without the key.

- b. An unauthorized user manages to gain access to encrypted records.
 - c. A data disk or laptop is stolen, giving the adversary access to the encrypted data.
2. The data layout is not changed on the storage medium and in transit. The encrypted data must be the same size as the plaintext data.
 3. Data are accessed in fixed sized blocks, independently from each other. That is, an authorized user may access one or more blocks in any order.
 4. Encryption is performed in 16-byte blocks, independently from other blocks (except the last two plaintext blocks of a sector, if its size is not a multiple of 16 bytes).
 5. There are no other metadata used, except the location of the data blocks within the whole data set.
 6. The same plaintext is encrypted to different ciphertexts at different locations, but always to the same ciphertext when written to the same location again.
 7. A standard conformant device can be constructed for decryption of data encrypted by another standard conformant device.

The P1619 group considered some of the existing modes of operation for use with stored data. For CTR mode, an adversary with write access to the encrypted media can flip any bit of the plaintext simply by flipping the corresponding ciphertext bit.

Next, consider requirement 6 and the use of CBC. To enforce the requirement that the same plaintext encrypts to different ciphertext in different locations, the IV could be derived from the sector number. Each sector contains multiple blocks. An adversary with read/write access to the encrypted disk can copy a ciphertext sector from one position to another within the same block, and an application reading the sector off the new location will still get the same plaintext sector (except perhaps the first 128 bits). Another weakness is that an adversary can flip any bit of the plaintext by flipping the corresponding ciphertext bit of the previous block, with the side-effect of “randomizing” the previous block.

Operation on a Single Block

Figure 7.10 shows the encryption and decryption of a single block. The operation involves two instances of the AES algorithm with two keys. The following parameters are associated with the algorithm.

- Key* The 256 or 512 bit XTS-AES key; this is parsed as a concatenation of two fields of equal size called Key_1 and Key_2 , such that $Key = Key_1 || Key_2$.
- P_j The j th block of plaintext. All blocks except possibly the final block have a length of 128 bits. A plaintext data unit, typically a disk sector, consists of a sequence of plaintext blocks P_1, P_2, \dots, P_m .
- C_j The j th block of ciphertext. All blocks except possibly the final block have a length of 128 bits.

- j The sequential number of the 128-bit block inside the data unit.
- i The value of the 128-bit tweak. Each data unit (sector) is assigned a tweak value that is a nonnegative integer. The tweak values are assigned consecutively, starting from an arbitrary nonnegative integer.
- α A primitive element of $GF(2^{128})$ that corresponds to polynomial x (i.e., $0000 \dots 010_2$).
- α^j α multiplied by itself j times, in $GF(2^{128})$.
- \oplus Bitwise XOR.
- \otimes Modular multiplication of two polynomials with binary coefficients modulo $x^{128} + x^7 + x^2 + x + 1$. Thus, this is multiplication in $GF(2^{128})$.

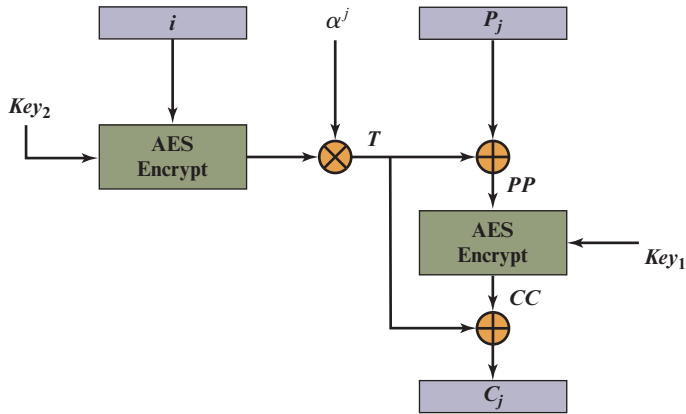

(a) Encryption

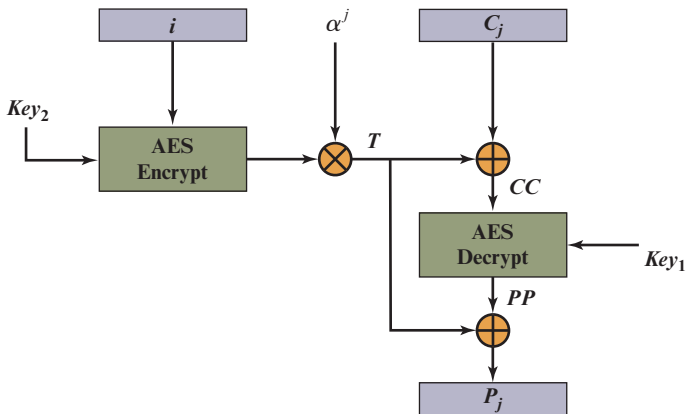

(b) Decryption

Figure 7.10 XTS-AES Operation on Single Block

In essence, the parameter j functions much like the counter in CTR mode. It assures that if the same plaintext block appears at two different positions within a data unit, it will encrypt to two different ciphertext blocks. The parameter i functions much like a nonce at the data unit level. It assures that, if the same plaintext block appears at the same position in two different data units, it will encrypt to two different ciphertext blocks. More generally, it assures that the same plaintext data unit will encrypt to two different ciphertext data units for two different data unit positions.

The encryption and decryption of a single block can be described as

XTS-AES block operation	$T = E(K_2, i) \otimes \alpha^j$	$T = E(K_2, i) \otimes \alpha^j$
	$PP = P \oplus T$	$CC = C \oplus T$
	$CC = E(K_1, PP)$	$PP = D(K_1, CC)$
	$C = CC \oplus T$	$P = PP \oplus T$

To see that decryption recovers the plaintext, let us expand the last line of both encryption and decryption. For encryption, we have

$$C = CC \oplus T = E(K_1, PP) \oplus T = E(K_1, P \oplus T) \oplus T$$

and for decryption, we have

$$P = PP \oplus T = D(K_1, CC) \oplus T = D(K_1, C \oplus T) \oplus T$$

Now, we substitute for C :

$$\begin{aligned} P &= D(K_1, C \oplus T) \oplus T \\ &= D(K_1, [E(K_1, P \oplus T) \oplus T] \oplus T) \oplus T \\ &= D(K_1, E(K_1, P \oplus T)) \oplus T \\ &= (P \oplus T) \oplus T = P \end{aligned}$$

Operation on a Sector

The plaintext of a sector or data unit is organized into blocks of 128 bits. Blocks are labeled P_0, P_1, \dots, P_m . The last block may be null or may contain from 1 to 127 bits. In other words, the input to the XTS-AES algorithm consists of m 128-bit blocks and possibly a final partial block.

For encryption and decryption, each block is treated independently and encrypted/decrypted as shown in Figure 7.10. The only exception occurs when the last block has less than 128 bits. In that case, the last two blocks are encrypted/decrypted using a **ciphertext-stealing** technique instead of padding. Figure 7.11 shows the scheme. P_{m-1} is the last full plaintext block, and P_m is the final plaintext block, which contains s bits with $1 \leq s \leq 127$. C_{m-1} is the last full ciphertext block, and C_m is the final ciphertext block, which contains s bits. This technique is commonly called ciphertext stealing because the processing of the last block “steals” a temporary ciphertext of the penultimate block to complete the cipher block.

Let us label the block encryption and decryption algorithms of Figure 7.10 as

Block encryption: XTS-AES-blockEnc(K, P_j, i, j)

Block decryption: XTS-AES-blockDec(K, C_j, i, j)

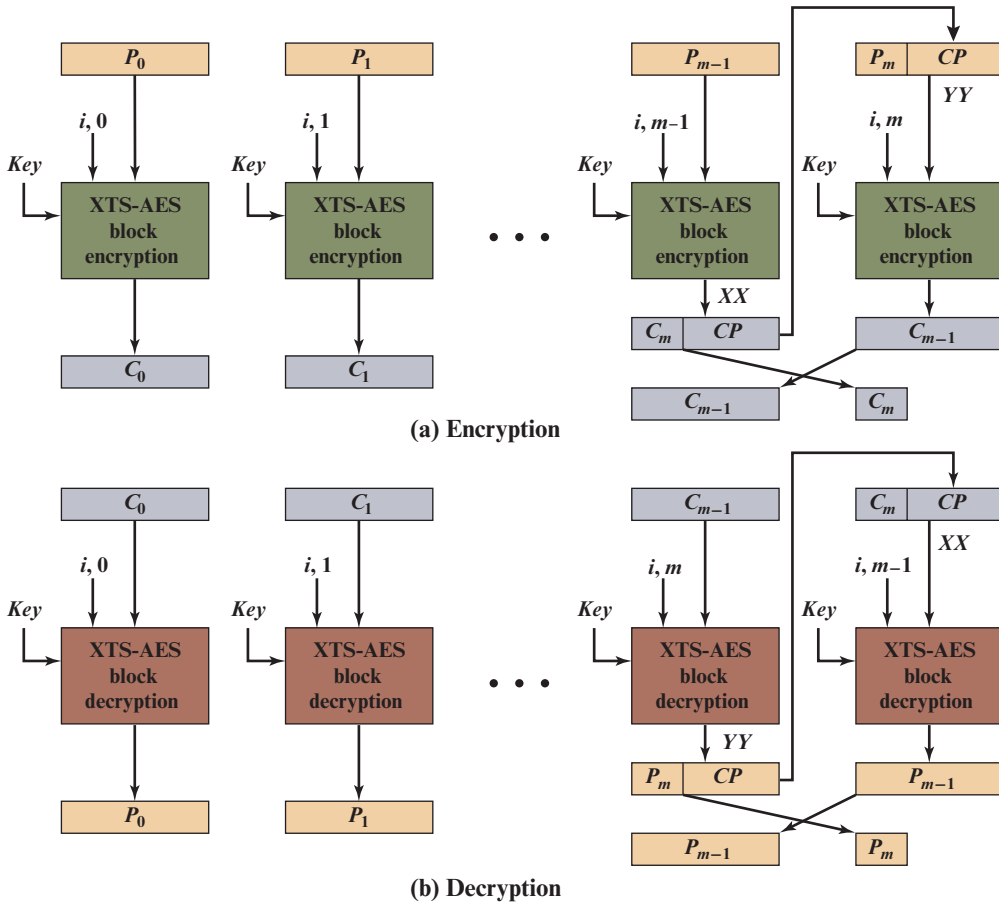

Figure 7.11 XTS-AES Mode

Then, XTS-AES mode is defined as follows:

XTS-AES mode with null final block	$C_j = \text{XTS-AES-blockEnc}(K, P_j, i, j) \quad j = 0, \dots, m - 1$
	$P_j = \text{XTS-AES-blockEnc}(K, C_j, i, j) \quad j = 0, \dots, m - 1$
XTS-AES mode with final block containing s bits	$C_j = \text{XTS-AES-blockEnc}(K, P_j, i, j) \quad j = 0, \dots, m - 2$
	$XX = \text{XTS-AES-blockEnc}(K, P_{m-1}, i, m - 1)$
	$CP = \text{LSB}_{128-s}(XX)$
	$YY = P_m \parallel CP$
	$C_{m-1} = \text{XTS-AES-blockEnc}(K, YY, i, m)$
	$C_m = \text{MSB}_s(XX)$
	$P_j = \text{XTS-AES-blockDec}(K, C_j, i, j) \quad j = 0, \dots, m - 2$
$YY = \text{XTS-AES-blockDec}(K, C_{m-1}, i, m - 1)$	
$CP = \text{LSB}_{128-s}(YY)$	
$XX = C_m \parallel CP$	
$P_{m-1} = \text{XTS-AES-blockDec}(K, XX, i, m)$	
$P_m = \text{MSB}_s(YY)$	

As can be seen, XTS-AES mode, like CTR mode, is suitable for parallel operation. Because there is no chaining, multiple blocks can be encrypted or decrypted simultaneously. Unlike CTR mode, XTS-AES mode includes a nonce (the parameter *i*) as well as a counter (parameter *j*).

7.8 FORMAT-PRESERVING ENCRYPTION

Format-preserving encryption (FPE) refers to any encryption technique that takes a plaintext in a given format and produces a ciphertext in the same format. For example, credit cards consist of 16 decimal digits. An FPE that can accept this type of input would produce a ciphertext output of 16 decimal digits. Note that the ciphertext need not be, and in fact is unlikely to be, a valid credit card number. But it will have the same format and can be stored in the same way as credit card number plaintext.

A simple encryption algorithm is not format preserving, with the exception that it preserves the format of binary strings. For example, Table 7.2 shows three types of plaintext for which it might be desired to perform FPE. The third row shows examples of what might be generated by an FPE algorithm. The fourth row shows (in hexadecimal) what is produced by AES with a given key.

Motivation

FPE facilitates the retrofitting of encryption technology to legacy applications, where a conventional encryption mode might not be feasible because it would disrupt data fields/pathways. FPE has emerged as a useful cryptographic tool, whose applications include financial-information security, data sanitization, and transparent encryption of fields in legacy databases.

The principal benefit of FPE is that it enables protection of particular data elements in a legacy database that did not provide encryption of those data elements, while still enabling workflows that were in place before FPE was in use. With FPE, as opposed to ordinary AES encryption or 3DES encryption, no database schema changes and minimal application changes are required. Only applications that need to see the plaintext of a data element need to be modified and generally these modifications will be minimal.

Some examples of legacy applications where FPE is desirable:

- COBOL data-processing applications: Any changes in the structure of a record requires corresponding changes in all code that references that record structure. Typical code sizes involve hundreds of modules, each containing around 5,000–10,000 lines on average.

Table 7.2 Comparison of Format-Preserving Encryption and AES

	Credit Card	Tax ID	Bank Account Number
Plaintext	8123 4512 3456 6780	219-09-9999	800N2982K-22
FPE	8123 4521 7292 6780	078-05-1120	709G9242H-35
AES (hex)	af411326466add24 c86abd8aa525db7a	7b9af4f3f218ab25 07c7376869313afa	9720ec7f793096ff d37141242e1c51bd

- Database applications: Fields that are specified to take only character strings cannot be used to store conventionally encrypted binary ciphertext. Base64 encoding of such binary ciphertext is not always feasible without increase in data lengths, requiring augmentation of corresponding field lengths.
- FPE-encrypted characters can be significantly compressed for efficient transmission. This cannot be said about AES-encrypted binary ciphertext.

Difficulties in Designing an FPE

A general-purpose standardized FPE should meet a number of requirements:

1. The ciphertext is of the same length and format as the plaintext.
2. It should be adaptable to work with a variety of character and number types. Examples include decimal digits, lowercase alphabetic characters, and the full character set of a standard keyboard or international keyboard.
3. It should work with variable plaintext lengths.
4. Security strength should be comparable to that achieved with AES.
5. Security should be strong even for very small plaintext lengths.

Meeting the first requirement is not at all straightforward. As illustrated in Table 7.2, a straightforward encryption with AES yields a 128-bit binary block that does not resemble the required format. Also, a standard symmetric block cipher is not easily adaptable to produce an FPE.

Consider a simple example. Assume that we want an algorithm that can encrypt decimal digit strings of maximum length of 32 digits. The input to the algorithm can be stored in 16 bytes (128 bits) by encoding each digit as four bits and using the corresponding binary value for each digit (e.g., 6 is encoded as 0101). Next, we use AES to encrypt the 128-bit block, in the following fashion:

1. The plaintext input X is represented by the string of 4-bit decimal digits $X[1] \dots X[16]$. If the plaintext is less than 16 digits long, it is padded out to the left (most significant) with zeros.
2. Treating X as a 128-bit binary string and using key K , form ciphertext $Y = \text{AES}_K(X)$.
3. Treat Y as a string of length 16 of 4-bit elements.
4. Some of the entries in Y may have values greater than 9 (e.g., 1100). To generate ciphertext Z in the required format, calculate

$$Z[i] = Y[i] \bmod 10, \quad 1 \leq i \leq 16$$

This generates a ciphertext of 16 decimal digits, which conforms to the desired format. However, this algorithm does not meet the basic requirement of any encryption algorithm of reversibility. It is impossible to decrypt Z to recover the original plaintext X because the operation is one-way; that is, it is a many-to-one function. For example, $12 \bmod 10 = 2 \bmod 10 = 2$. Thus, we need to design a reversible function that is both a secure encryption algorithm and format preserving.

A second difficulty in designing an FPE is that some of the input strings are quite short. For example, consider the 16-digit credit card number (CCN). The first six digits provide the issuer identification number (IIN), which identifies the institution that issued the card. The final digit is a check digit to catch typographical errors or other mistakes. The remaining nine digits are the user's account number. However, a number of applications require that the last four digits be in the clear (the check digit plus three account digits) for applications such as credit card receipts, which leaves only six digits for encryption. Now suppose that an adversary is able to obtain a number of plaintext/ciphertext pairs. Each such pair corresponds to not just one CCN, but multiple CCNs that have the same middle six digits. In a large database of credit card numbers, there may be multiple card numbers with the same middle six digits. An adversary may be able to assemble a large dictionary mapping known as six-digit plaintexts to their corresponding ciphertexts. This could be used to decrypt unknown ciphertexts from the database. As pointed out in [BELL10a], in a database of 100 million entries, on average about 100 CCNs will share any given middle-six digits. Thus, if the adversary has learned k CCNs and gains access to such a database, the adversary can decrypt approximately $100k$ CCNs.

The solution to this second difficulty is to use a tweakable block cipher; this concept is described in Section 7.7. For example, the tweak for CCNs could be the first two and last four digits of the CCN. Prior to encryption, the tweak is added, digit-by-digit mod 10, to the middle six-digit plaintext, and the result is then encrypted. Two different CCNs with identical middle six digits will yield different tweaked inputs and therefore different ciphertexts. Consider the following:

CCN	Tweak	Plaintext	Plaintext + Tweak
4012 8812 3456 1884	401884	123456	524230
5105 1012 3456 6782	516782	123456	639138

Two CCNs with the same middle six digits have different tweaks and therefore different values to the middle six digits after the tweak is added.

Feistel Structure for Format-Preserving Encryption

As the preceding discussion shows, the challenge with FPE is to design an algorithm for scrambling the plaintext that is secure, preserves format, and is reversible. A number of approaches have been proposed in recent years [ROGA10, BELL09] for FPE algorithms. The majority of these proposals use a Feistel structure. Although IBM introduced this structure with their Lucifer cipher [SMIT71] almost half a century ago, it remains a powerful basis for implementing ciphers.

This section provides a general description of how the Feistel structure can be used to implement an FPE. In the following section, we look at three specific Feistel-based algorithms that are in the process of receiving NIST approval.

ENCRYPTION AND DECRYPTION Figure 7.12 shows the Feistel structure used in all of the NIST algorithms, with encryption shown on the left-hand side and decryption on the right-hand side. The structure in Figure 7.12 is the same as that shown in

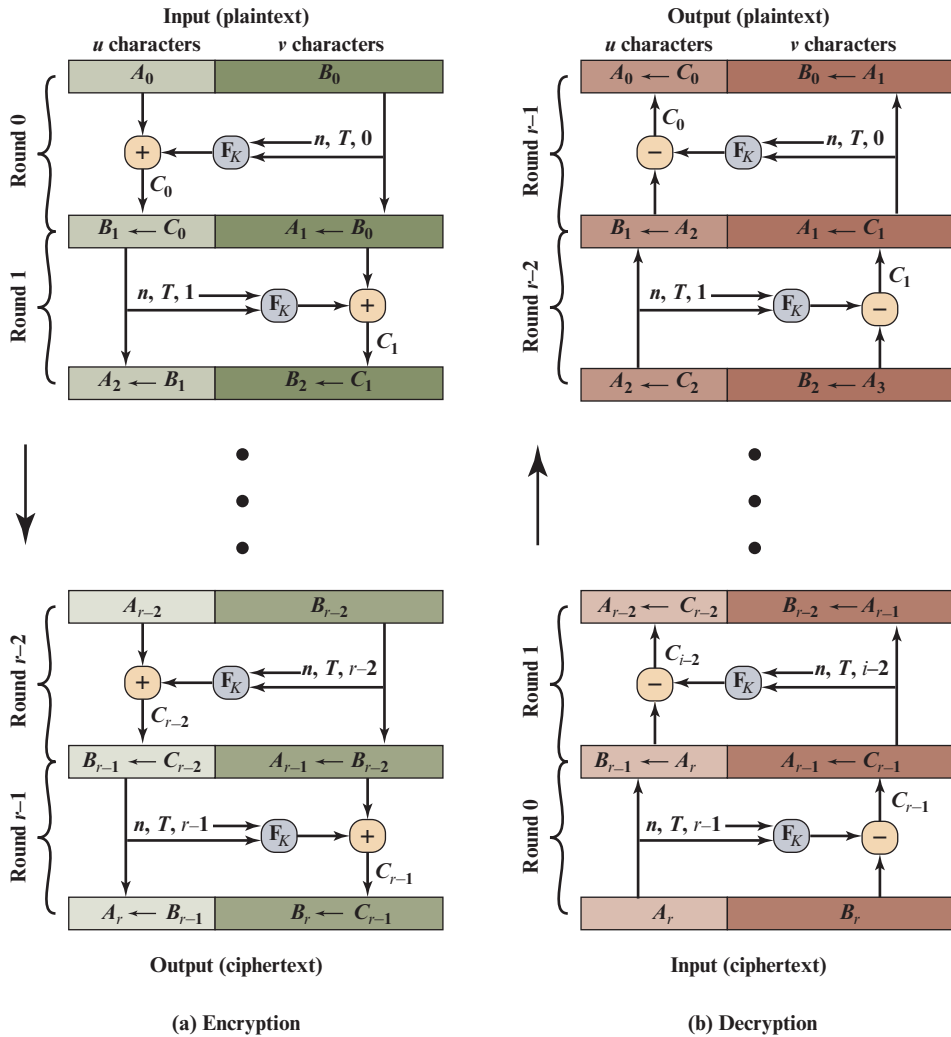

Figure 7.12 Feistel Structure for Format-Preserving Encryption

Figure 4.3 but, to simplify the presentation, it is untwisted, not illustrating the swap that occurs at the end of each round.

The input to the encryption algorithm is a plaintext character string of $n = u + v$ characters. If n is even, then $u = v$, otherwise u and v differ by 1. The two parts of the string pass through an even number of rounds of processing to produce a ciphertext block of n characters and the same format as the plaintext. Each round i has inputs A_i and B_i , derived from the preceding round (or plaintext for round 0).

All rounds have the same structure. On even-numbered rounds, a substitution is performed on the left part (length u) of the data, A_i . This is done by applying the round function F_K to the right part (length v) of the data, B_i , and then performing

a modular addition of the output of F_K with A_r . The modular addition function and the selection of modulus are described subsequently. On odd-numbered rounds, the substitution is done on the right part of the data. F_K is a one-way function that converts the input into a binary string, performs a scrambling transformation on the string, and then converts the result back into a character string of suitable format and length. The function has as parameters the secret key K , the plaintext length n , a tweak T , and the round number i .

Note that on even-numbered rounds, F_K has an input of v characters, and that the modular addition produces a result of u characters, whereas on odd-numbered rounds, F_K has an input of u characters, and that the modular addition produces a result of v characters. The total number of rounds is even, so that the output consists of an A portion of length u concatenated with a B portion of length v , matching the partition of the plaintext.

The process of decryption is essentially the same as the encryption process. The differences are: (1) the addition function is replaced by a subtraction function that is its inverse; and (2) the order of the round indices is reversed.

To demonstrate that the decryption produces the correct result, Figure 7.12b shows the encryption process going down the left-hand side and the decryption process going up the right-hand side. The diagram indicates that, at every round, the intermediate value of the decryption process is equal to the corresponding value of the encryption process. We can walk through the figure to validate this, starting at the bottom. The ciphertext is produced at the end of round $r - 1$ as a string of the form $A_r \| B_r$, with A_r and B_r having string lengths u and v , respectively. Encryption round $r - 1$ can be described with the following equations:

$$\begin{aligned} A_r &= B_{r-1} \\ B_r &= A_{r-1} + F_K[B_{r-1}] \end{aligned}$$

Because we define the subtraction function to be the inverse of the addition function, these equations can be rewritten:

$$\begin{aligned} B_{r-1} &= A_r \\ A_{r-1} &= B_r - F_K[B_{r-1}] \end{aligned}$$

It can be seen that the last two equations describe the action of round 0 of the decryption function, so that the output of round 0 of decryption equals the input of round $r - 1$ of encryption. This correspondence holds all the way through the r iterations, as is easily shown.

Note that the derivation does not require that F be a reversible function. To see this, take a limiting case in which F produces a constant output (e.g., all ones) regardless of the values of its input. The equations still hold.

CHARACTER STRINGS The NIST algorithms, and the other FPE algorithms that have been proposed, are used with plaintext consisting of a string of elements, called characters. Specifically, a finite set of two or more symbols is called an *alphabet*, and the elements of an alphabet are called *characters*. A *character string* is a finite sequence of characters from an alphabet. Individual characters may repeat in the string. The number of different characters in an alphabet is called the *base*, also

referred to as the *radix* of the alphabet. For example, the lowercase English alphabet a, b, c, . . . has a radix, or base, of 26. For purposes of encryption and decryption, the plaintext alphabet must be converted to numerals, where a *numeral* is a nonnegative integer that is less than the base. For example, for the lowercase alphabet, the assignment could be characters a, b, c, . . . , z map into 0, 1, 2, . . . , 25.

A limitation of this approach is that all of the elements in a plaintext format must have the same radix. So, for example, an identification number that consists of an alphabetic character followed by nine numeric digits cannot be handled in format-preserving fashion by the FPEs that have been implemented so far.

The NIST document defines notation for specifying these conversions (Table 7.3a). To begin, it is assumed that the character string is represented by a numeral string. To convert a numeral string X into a number x , the function $\text{NUM}_{\text{radix}}(X)$ is used. Viewing X as the string $X[1] \dots X[m]$ with the most significant numeral first, the function is defined as

$$\text{NUM}_{\text{radix}}(X) = \sum_{i=1}^m X[i] \text{radix}^{m-i} = \sum_{i=0}^{m-1} X[m-i] \text{radix}^i$$

Observe that $0 \leq \text{NUM}_{\text{radix}}(X) < \text{radix}^m$ and that $0 \leq X[i] < \text{radix}$.

Table 7.3 Notation and Parameters Used in FPE Algorithms

$[x]^s$	Converts an integer into a byte string; it is the string of s bytes that encodes the number x , with $0 \leq x < 2^{8s}$. The equivalent notation is $\text{STR}_2^{8s}(x)$.
$\text{LEN}(X)$	Length of the character string X .
$\text{NUM}_{\text{radix}}(X)$	Converts strings to numbers. The number that the numeral string X represents in base radix , with the most significant character first. In other words, it is the nonnegative integer less than $\text{radix}^{\text{LEN}(X)}$ whose most-significant-character-first representation in base radix is X .
$\text{PRF}_K(X)$	A pseudorandom function that produces a 128-bit output with X as the input, using encryption key K .
$\text{STR}_{\text{radix}}^m(x)$	Given a nonnegative integer x less than radix^m , this function produces a representation of x as a string of m characters in base radix , with the most significant character first.
$[i..j]$	The set of integers between two integers i and j , including i and j .
$X[i..j]$	The substring of characters of a string X from $X[i]$ to $X[j]$, including $X[i]$ and $X[j]$.
$\text{REV}(X)$	Given a bit string, X , the string that consists of the bits of X in reverse order.

(a) Notation

<i>radix</i>	The base, or number of characters, in a given plaintext alphabet.
<i>tweak</i>	Input parameter to the encryption and decryption functions whose confidentiality is not protected by the mode.
<i>tweakradix</i>	The base for tweak strings
<i>minlen</i>	Minimum message length, in characters.
<i>maxlen</i>	Maximum message length, in characters.
<i>maxTlen</i>	Maximum tweak length

(b) Parameters

For example, consider the string *zaby* in radix 26, which converts to the numeral string 25 0 1 24. This converts to the number $x = (25 \times 26^3) + (1 \times 26^1) + 24 = 439450$. To go in the opposite direction and convert from a number $x < \text{radix}^m$ to a numeral string X of length m , the function $\text{STR}_{\text{radix}}^m(x)$ is used:

$$\text{STR}_{\text{radix}}^m(x) = X[1] \dots X[m], \text{ where}$$

$$X[i] = \left\lfloor \frac{x}{\text{radix}^{m-i}} \right\rfloor \bmod \text{radix}, \quad i = 1, \dots, m$$

With the mapping of characters to numerals and the use of the NUM function, a plaintext character string can be mapped to a number and stored as an unsigned integer. We would like to treat this unsigned integer as a bit string that can be input to a bit-scrambling algorithm in F_K . However, different platforms store unsigned integers differently, some in little-endian and some in big-endian fashion. So one more step is needed. By the definition of the STR function, $\text{STR}_2^{8s}(x)$ will generate a bit string of length $8s$, equivalently a byte string of length s , which is a binary integer with the most significant bit first, regardless of how x is stored as an unsigned integer. For convenience the following notation is used: $[x]^s = \text{STR}_2^{8s}(x)$. Thus, $[\text{NUM}_{\text{radix}}(X)]^s$ will convert the character string X into an unsigned integer and then convert that to a byte string of length s bytes with the most significant bit first.

Continuing, the preceding example should help clarify the issues involved.

Character string	“zaby”
Numeral string X representation of character string	25 0 1 24
Convert X to number $x = \text{NUM}_{26}(X)$	decimal: 439450 hex: 6B49A binary: 1101011010010011010
x stored on big-endian byte order machine as a 32-bit unsigned integer	hex: 00 06 B4 9A binary: 000000000000001101011010010011010
x stored on little-endian byte order machine as a 32-bit unsigned integer	hex: 9A B4 06 00 binary: 10011010101101000000011000000000
Convert x , regardless of endian format, to a bit string of length 32 bits (4 bytes), expressed as $[x]^4$	0000000000001101011010010011010

THE FUNCTION F_K We can now define in general terms the function F_K . The core of F_K is some type of randomizing function whose input and output are bit strings. For convenience, the strings should be multiples of 8 bits, forming byte strings. Define m to be u for even rounds and v for odd rounds; this specifies the desired output character string length. Define b to be the number of bytes needed to store the number representing a character string of m bytes. Then the round,

including F_K , consists of the following general steps (A and B refer to A_i and B_i for round i):

1. $Q \leftarrow [\text{NUM}_{\text{radix}}(X)]^b E$	Converts numeral string X into byte string Q of length b bytes.
2. $Y \leftarrow \text{RAN}[Q]$	A pseudorandom function PRNF that produces a pseudorandom byte string Y as a function of the bits of Q .
3. $y \leftarrow \text{NUM}_2(Y)$	Converts Y into unsigned integer.
4. $c \leftarrow (\text{NUM}_{\text{radix}}(A) + y) \bmod \text{radix}^m$	Converts numeral string A into an integer and adds to y , modulo radix^m .
5. $C \leftarrow \text{STR}_{\text{radix}}^m(c)$	Converts c into a numeral string C of length m .
6. $A \leftarrow B;$ $B \leftarrow C$	Completes the round by placing the unchanged value of B from the preceding round into A , and placing C into B .

Steps 1 through 3 constitute the round function F_K . Step 3 is presented with Y , which is an unstructured bit string. Because different platforms may store unsigned integers using different word lengths and endian conventions, it is necessary to perform $\text{NUM}_2(Y)$ to get an unsigned integer y . The stored bit sequence for y may or may not be identical to the bit sequence for Y .

As mentioned, the pseudorandom function in step 2 need not be reversible. Its purpose is to provide a randomized, scrambled bit string. For DES, this is achieved by using fixed S-boxes, as described in Appendix C. Virtually all FPE schemes that use the Feistel structure use AES as the basis for the scrambling function to achieve stronger security.

RELATIONSHIP BETWEEN RADIX, MESSAGE LENGTH, AND BIT LENGTH Consider a numeral string X of length len and base $radix$. If we convert this to a number $x = \text{NUM}_{\text{radix}}(X)$, then the maximum value of x is $\text{radix}^{len} - 1$. The number of bits needed to encode x is

$$\text{bitlen} = \lceil \text{LOG}_2(\text{radix}^{len}) \rceil = \lceil len \text{LOG}_2(\text{radix}) \rceil$$

Observe that an increase in either $radix$ or len increases bitlen . Often, we want to limit the value of bitlen to some fixed upper limit, for example, 128 bits, which is the size of the input to AES encryption. We also want the FPE to handle a variety of radix values. The typical FPE, and all of those discussed subsequently, allow a given range of radix values and then define a maximum character string length in order to provide the algorithm with a fixed value of bitlen . Let the range of radix values be from 2 to maxradix , and the maximum allowable character string value be maxlen . Then the following relationship holds:

$$\begin{aligned} \text{maxlen} &\leq \lfloor \text{bitlen} / \text{LOG}_2(\text{radix}) \rfloor, \text{ or equivalently} \\ \text{maxlen} &\leq \lfloor \text{bitlen} \times \text{LOG}_{\text{radix}}(2) \rfloor \end{aligned}$$

For example, for a radix of 10, $\text{maxlen} \leq \lfloor 0.3 \times \text{bitlen} \rfloor$; for a radix of 26, $\text{maxlen} \leq \lfloor 0.21 \times \text{bitlen} \rfloor$. The larger the radix, the smaller the maximum character length for a given bit length.

NIST Methods for Format-Preserving Encryption

In 2013, NIST issued SP 800-38G: *Recommendation for Block Cipher Modes of Operation: Methods for Format-Preserving Encryption*. This Recommendation specifies three methods for format-preserving encryption, called FF1, FF2, and FF3. The three methods all use the Feistel structure shown in Figure 7.12. They employ somewhat different round functions F_K , which are built using AES. Important differences are the following:

- FF1 supports the greatest range of lengths for the plaintext character string and the tweak. To achieve this, the round function uses a cipher-block-chaining (CBC) style of encryption, whereas FF2 and FF3 employ simple electronic codebook (ECB) encryption.
- FF2 uses a subkey generated from the encryption key and the tweak, whereas FF1 and FF3 use the encryption key directly. The use of a subkey may help protect the original key from side-channel analysis, which is an attack based on information gained from the physical implementation of a cryptosystem, rather than brute force or cryptanalysis. Examples of such attacks are attempts to deduce key bits based on power consumption or execution time.
- FF3 offers the lowest round count, eight, compared to ten for FF1 and FF2, and is the least flexible in the tweaks that it supports.

ALGORITHM FF1 Algorithm FF1 was submitted to NIST as a proposed FPE mode [BELL10a, BELL10b] with the name FFX[Radix]. FF1 uses a pseudorandom function $\text{PRF}_K(X)$ that produces a 128-bit output with inputs X that is a multiple of 128 bits and encryption key K (Figure 7.13). In essence, $\text{PRF}_K(X)$ use CBC encryption (Figure 7.4) with X as the plaintext input, encryption key K , and an initial vector (IV) of all zeros. The output is the last block of ciphertext produced. This is also

Prerequisites:

Approved, 128-bit block cipher, CIPH;

Key, K , for the block cipher;

Input:

Nonempty bit string, X , such that $\text{LEN}(X)$ is a multiple of 128.

Output:

128-bit block, Y

Steps:

1. Let $m = \text{LEN}(X)/128$.
2. Partition X into m 128-bit blocks X_1, \dots, X_m , so that $X = X_1 \parallel \dots \parallel X_m$
3. Let $Y_0 = [0]^{16}$
4. For j from 1 to m :
5. let $Y_j = \text{CIPH}_K(Y_{j-1} \oplus X_j)$.
6. Return Y_m .

Figure 7.13 Algorithm $\text{PRF}(X)$

equivalent to the message authentication code known as CBC-MAC, or CMAC, described in Chapter 12.

The FF1 encryption algorithm is illustrated in Figure 7.14. The shaded lines correspond to the function F_K . The algorithm has 10 rounds and the following parameters (Table 7.3b):

- $radix \in [2 .. 2^{16}]$
- $radix^{minlen} \geq 100$
- $minlen \geq 2$
- $maxlen < 2^{32}$. For the maximum radix value of 2^{16} , the maximum bit length to store the integer value of X is 16×2^{32} bits; for the minimum radix value of 2, the maximum bit length to store the integer value of X is 2^{32} bits.
- $maxTlen < 2^{32}$

The inputs to the encryption algorithm are a character string X of length n and a tweak T of length t . The tweak is optional in that it may be the empty string.

<p><i>Prerequisites:</i> Approved, 128-bit block cipher, CIPH; Key, K, for the block cipher; Base, $radix$, for the character alphabet; Range of supported message lengths, $[minlen .. maxlen]$; Maximum byte length for tweaks, $maxTlen$.</p> <p><i>Inputs:</i> Character string, X, in base $radix$ of length n such that $n \in [minlen .. maxlen]$; Tweak T, a byte string of byte length t, such that $t \in [0 .. maxTlen]$.</p> <p><i>Output:</i> Character string, Y, such that $LEN(Y) = n$.</p> <p><i>Steps:</i></p> <ol style="list-style-type: none"> 1. Let $u = \lfloor n/2 \rfloor$; $v = n - u$. 2. Let $A = X[1 .. u]$; $B = X[u + 1 .. n]$. 3. Let $b = \lceil \lceil v \log_2(radix) \rceil / 8 \rceil$; $d = 4 \lceil b/4 \rceil + 4$ 4. Let $P = [1]^1 \parallel [2]^1 \parallel [1]^1 \parallel [radix]^3 \parallel [10]^1 \parallel [u \bmod 256]^1 \parallel [n]^4 \parallel [t]^4$. 5. For i from 0 to 9: <ol style="list-style-type: none"> i. Let $Q = T \parallel [0]^{(-t-b-1) \bmod 16} \parallel [i]^1 \parallel [NUM_{radix}(B)]^b$. ii. Let $R = PRF_K(P \parallel Q)$. iii. Let S be the first d bytes of the following string of $\lceil d/16 \rceil$ 128-bit blocks: $R \parallel CIPH_K(R \oplus [1]^{16}) \parallel CIPH_K(R \oplus [2]^{16}) \parallel \dots \parallel CIPH_K(R \oplus [\lceil d/16 \rceil - 1]^{16})$. iv. Let $y = NUM_2(S)$. v. If i is even, let $m = u$; else, let $m = v$. vi. Let $c = (NUM_{radix}(A) + y) \bmod radix^m$. vii. Let $C = STR_{radix}^m(c)$. viii. Let $A = B$. ix. Let $B = C$. 6. Return $Y = A \parallel B$.
--

Figure 7.14 Algorithm FF1 (FFX[Radix])

The output is the encrypted character string Y of length n . What follows is a step-by-step description of the algorithm.

- 1., 2. The input X is split into two substrings A and B . If n is even, A and B are of equal length. Otherwise, B is one character longer than A .
3. The expression $\lceil v \text{ LOG}_2(\text{radix}) \rceil$ equals the number of bits needed to encode B , which is v characters long. Encoding B as a byte string, b is the number of bytes in the encoding. The definition of d ensures that the output of the Feistel round function is at least 4 bytes longer than this encoding of B , which minimizes any bias in the modular reduction in step 5.vi, as explained subsequently.
4. P is a 128-bit (16-byte) block that is a function of radix , u , n , and t . It serves as the first block of plaintext input to the CBC encryption mode used in 5.ii, and is intended to increase security.
5. The loop through the 10 rounds of encryption.
 - 5.i The tweak, T , the substring, B , and the round number, i , are encoded as a binary string, Q , which is one or more 128-bit blocks in length. To understand this step, first note that the value $\text{NUM}_{\text{radix}}(B)$ produces a numeral string that represents B in base radix . How this numeral string is formatted and stored is outside the scope of the standard. Then, the value $[\text{NUM}_{\text{radix}}(B)]^b$ produces the representation of the numerical value of B as a binary number in a string of b bytes. We also have the length of T is t bytes, and the round number is stored in a single byte. This yields a length of $(t + b + 1)$ bytes. This is padded out with $z = (-t - b - 1) \bmod 16$ bytes. From the rules of modular arithmetic, we know that $(z + t + b + 1) \bmod 16 = 0$. Thus the length of Q is one or more 128-bit blocks.
 - 5.ii The concatenation of P and Q is input to the pseudorandom function PRF to produce a 128-bit output R . This function is the pseudorandom core of the Feistel round function. It scrambles the bits of B_i (Figure 7.12).
 - 5.iii This step either truncates or expands R to a byte string S of length d bytes. That is, if $d \leq 16$ bytes, then R is the first d bytes of R . Otherwise the 16-byte R is concatenated with successive encryptions of R XORed with successive constants to produce the shortest string of 16-byte blocks whose length is greater than or equal to d bytes.
 - 5.iv This step begins the process of converting the results of the scrambling of B_i into a form suitable for combining with A_i . In this step, the d -byte string S is converted into a numeral string in base 2 that represents S . That is, S is represented as a binary string y .
 - 5.v This step determines the length m of the character string output that is required to match the length of the B portion of the round output. For even-numbered rounds, the length is u characters, and for odd-numbered rounds it is v characters, as shown in Figure 7.12.
 - 5.vi The numerical values of A and y are added modulo radix^m . This truncates the value of the sum to a value c that can be stored in m characters.

- 5.vii This step converts the c into the proper representation C as a string of m characters.
- 5.viii, 5.ix These steps complete the round by placing the unchanged value of B from the preceding round into A , and placing C into B .
- 6. After the final round, the result is returned as the concatenation of A and B .

It may be worthwhile to clarify the various uses of the NUM function in FF1. NUM converts strings with a given radix into integers. In step 5.i, B is a character string in base radix, so $\text{NUM}_{\text{radix}}(B)$ converts this into an integer, which is stored as a byte string, suitable for encryption in step 5.ii. For step 5.iv, S is a byte string output of an encryption function, which can be viewed a bit string, so $\text{NUM}_2(S)$ converts this into an integer.

Finally, a brief explanation of the variable d is in order, which is best explained by example. Let $\text{radix} = 26$ and $v = 30$ characters. Then $b = 18$ bytes, and $d = 24$ bytes. Step 5.ii produces an output R of 16 bytes. We desire a scrambled output of b bytes to match the input, and so R needs to be padded out. Rather than padding with a constant value such as all zeros, step 5.iii pads out with random bits. The result, in step 5.iv is a number greater than radix^m of fully randomized bits. The use of randomized padding avoids a potential security risk of using a fixed padding.

ALGORITHM FF2 Algorithm FF2 was submitted to NIST as a proposed FPE mode with the name VAES3 [VANC11]. The encryption algorithm is defined in Figure 7.15. The shaded lines correspond to the function F_K . The algorithm has the following parameters:

- $\text{radix} \in [2 .. 2^8]$
- $\text{tweakradix} \in [2 .. 2^8]$
- $\text{radix}^{\text{minlen}} \geq 100$
- $\text{minlen} \geq 2$
- $\text{maxlen} \leq 2 \lfloor 120 / \text{LOG}_2(\text{radix}) \rfloor$ if radix is a power of 2. For the maximum radix value of 2^8 , $\text{maxlen} \leq 30$; for the minimum radix value of 2, $\text{maxlen} \leq 240$. In both cases, the maximum bit length to store the integer value of X is 240 bits, or 30 bytes.
- $\text{maxlen} \leq 2 \lfloor 98 / \text{LOG}_2(\text{radix}) \rfloor$ if radix is a not a power of 2. For the maximum radix value of 255, $\text{maxlen} \leq 24$; for the minimum radix value of 3, $\text{maxlen} \leq 124$.
- $\text{maxTlen} \leq \lfloor 104 / \text{LOG}_2(\text{tweakradix}) \rfloor$. For the maximum tweakradix value of 2^8 , $\text{maxTlen} \leq 13$.

For FF2, the plaintext character alphabet and that of the tweak may be different.

The first two steps of FF2 are the same as FF1, setting values for v , u , A , and B . FF2 proceeds with the following steps:

- 3. P is a 128-bit (16-byte) block. If there is a tweak, then P is a function of radix , t , n , and the 13-byte numerical value of the tweak. If there is no tweak ($t = 0$), then P is a function of radix and n . P is used to form an encryption key in step 4.
- 4. J is the encryption of P using the input key K .

Approved, 128-bit block cipher, CIPH;
 Key, K , for the block cipher;
 Base, $tweakradix$, for the tweak character alphabet;
 Range of supported message lengths, $[minlen .. maxlen]$;
 Maximum supported tweak length, $maxTlen$.

Inputs:
 Numeral string, X , in base $radix$, of length n such that $n \in [minlen .. maxlen]$;
 Tweak numeral string, T , in base $tweakradix$, of length t such that $t \in [0 .. maxTlen]$.

Output:
 Numeral string, Y , such that $LEN(Y) = n$.

Steps:

1. Let $u = \lfloor n/2 \rfloor$; $v = n - u$.
2. Let $A = X[1 .. u]$; $B = X[u + 1 .. n]$.
3. If $t > 0$, $P = [radix]^1 \parallel [t]^1 \parallel [n]^1 \parallel [NUM_{tweakradix}(T)]^{13}$; else $P = [radix]^1 \parallel [0]^1 \parallel [n]^1 \parallel [0]^{13}$.
4. Let $J = CIPH_K(P)$.
5. For i from 0 to 9:
 - i. Let $Q \leftarrow [i]^1 \parallel [NUM_{radix}(B)]^{15}$
 - ii. Let $Y \leftarrow CIPH_J(Q)$.
 - iii. Let $y \leftarrow NUM_2(Y)$.
 - iv. If i is even, let $m = u$; else, let $m = v$.
- v. Let $c = (NUM_{radix}(A) + y) \bmod radix^m$.
- vi. Let $C = STR_{radix}^m(c)$.
- vii. Let $A = B$.
- viii. Let $B = C$.

- 6. Return $Y = A \parallel B$.

Figure 7.15 Algorithm FF2 (VAES3)

5. The loop through the 10 rounds of encryption.
- 5.i B is converted into a 15-byte number, prepended by the round number to form a 16-byte block Q .
- 5.ii Q is encrypted using the encryption key J to yield Y .

The remaining steps are the same as for FF1. The essential difference is in the way in which all of the parameters are incorporated into the encryption that takes place in the block F_K . In both cases, the encryption is not simply an encryption of B using key K . For FF1, B is combined with the tweak, the round number, t , n , u , and $radix$ to form a string of multiple 16-byte blocks. Then CBC encryption is used with K to produce a 16-byte output. For FF2, all of the parameters besides B are combined to form a 16-byte block, which is then encrypted with K to form the key value J . J is then used as the key for the one-block encryption of B .

The structure of FF2 explains the maximum length restrictions. In step 3, P incorporates the radix, tweak length, the numeral string length, and the tweak into the calculation. As input to AES, P is restricted to 16 bytes. With a maximum radix value of 2^8 , the radix value can be stored in one byte (byte value 0 corresponds to 256). The string length n and tweak length t each easily fits into one byte. This leaves a restriction that the value of the tweak should be stored in at most 13 bytes,

or 104 bits. The number of bits to store the tweak is $\text{LOG}_2(\text{tweakradix}^{Tlen})$. This leads to the restriction $\text{maxTlen} \geq \lfloor 104/\text{LOG}_2(\text{tweakradix}) \rfloor$. Similarly step 5i incorporates B and the round number into a 16-byte input to AES, leaving 15 bytes to encode B , or 120 bits, so that the length must be less than or equal to $\lfloor 120/\text{LOG}_2(\text{radix}) \rfloor$. The parameter maxlen refers to the entire block, consisting of partitions A and B , thus $\text{maxlen} \geq 2 \lfloor 120/\text{LOG}_2(\text{radix}) \rfloor$.

There is a further restriction on maxlen for a radix that is not a power of 2. As explained in [VANC11], when the radix is not a power of 2, modular arithmetic causes the value $(y \bmod \text{radix}^m)$ to not have uniform distribution in the output space, which can result in a cryptographic weakness.

ALGORITHM FF3 Algorithm FF3 was submitted to NIST as a proposed FPE mode with the name BPS-BC [BRIE10]. The encryption algorithm is illustrated in Figure 7.16. The shaded lines correspond to the function F_K . The algorithm has the following parameters:

- $\text{radix} \in [2 .. 2^{16}]$
- $\text{radix}^{\text{minlen}} \geq 100$
- $\text{minlen} \geq 2$

<p>Approved, 128-bit block cipher, CIPH; Key, K, for the block cipher; Base, radix, for the character alphabet such that $\text{radix} \in [2..2^{16}]$; Range of supported message lengths, $[\text{minlen} .. \text{maxlen}]$, such that $\text{minlen} \geq 2$ and $\text{maxlen} \leq 2 \lfloor \log_{\text{radix}}(2^{96}) \rfloor$.</p> <p><i>Inputs:</i> Numeral string, X, in base radix of length n such that $n \in [\text{minlen} .. \text{maxlen}]$; Tweak bit string, T, such that $\text{LEN}(T) = 64$.</p> <p><i>Output:</i> Numeral string, Y, such that $\text{LEN}(Y) = n$.</p> <p><i>Steps:</i></p> <ol style="list-style-type: none"> 1. Let $u = \lceil n/2 \rceil$; $v = n - u$. 2. Let $A = X[1 .. u]$; $B = X[u + 1 .. n]$. 3. Let $T_L = T[0 .. 31]$ and $T_R = T[32 .. 63]$. 4. For i from 0 to 7: <table border="1" style="width: 100%; border-collapse: collapse; margin-top: 5px;"> <tr> <td style="padding: 5px;"> <ol style="list-style-type: none"> i. If i is even, let $m = u$ and $W = T_R$, else let $m = v$ and $W = T_L$. ii. Let $P = \text{REV}([\text{NUM}_{\text{radix}}(\text{REV}(B))]^{12}) \parallel [W \oplus \text{REV}([i]^4)]$. iii. Let $Y = \text{CIPH}_K(P)$. iv. Let $y = \text{NUM}_2(\text{REV}(Y))$. </td> </tr> <tr> <td style="padding: 5px;"> <ol style="list-style-type: none"> v. Let $c = (\text{NUM}_{\text{radix}}(\text{REV}(A)) + y) \bmod \text{radix}^m$. vi. Let $C = \text{REV}(\text{STR}_{\text{radix}}^m(c))$. vii. Let $A = B$. viii. Let $B = C$. </td> </tr> </table> 5. Return $A \parallel B$. 	<ol style="list-style-type: none"> i. If i is even, let $m = u$ and $W = T_R$, else let $m = v$ and $W = T_L$. ii. Let $P = \text{REV}([\text{NUM}_{\text{radix}}(\text{REV}(B))]^{12}) \parallel [W \oplus \text{REV}([i]^4)]$. iii. Let $Y = \text{CIPH}_K(P)$. iv. Let $y = \text{NUM}_2(\text{REV}(Y))$. 	<ol style="list-style-type: none"> v. Let $c = (\text{NUM}_{\text{radix}}(\text{REV}(A)) + y) \bmod \text{radix}^m$. vi. Let $C = \text{REV}(\text{STR}_{\text{radix}}^m(c))$. vii. Let $A = B$. viii. Let $B = C$.
<ol style="list-style-type: none"> i. If i is even, let $m = u$ and $W = T_R$, else let $m = v$ and $W = T_L$. ii. Let $P = \text{REV}([\text{NUM}_{\text{radix}}(\text{REV}(B))]^{12}) \parallel [W \oplus \text{REV}([i]^4)]$. iii. Let $Y = \text{CIPH}_K(P)$. iv. Let $y = \text{NUM}_2(\text{REV}(Y))$. 		
<ol style="list-style-type: none"> v. Let $c = (\text{NUM}_{\text{radix}}(\text{REV}(A)) + y) \bmod \text{radix}^m$. vi. Let $C = \text{REV}(\text{STR}_{\text{radix}}^m(c))$. vii. Let $A = B$. viii. Let $B = C$. 		

Figure 7.16 Algorithm FF3 (BPS-BC)

- $maxlen \leq 2 \lfloor \text{LOG}_{radix}(2^{96}) \rfloor$. For the maximum radix value of 2^{16} , $maxlen \leq 12$; for the minimum radix value of 2, $maxlen \leq 192$. In both cases, the maximum bit length to store the integer value of X is 192 bits, or 24 bytes.

- Tweak length = 64 bits

FF3 proceeds with the following steps:

- 1., 2. The input X is split into two substrings A and B . If n is even, A and B are of equal length. Otherwise, A is one character longer than B , in contrast to FF1 and FF2, where B is one character longer than A .
3. The tweak is partitioned into a 32-bit left tweak T_L and a 32-bit right tweak T_R .
4. The loop through the 8 rounds of encryption.
 - 4.i As in FF1 and FF2, this step determines the length m of the character string output that is required to match the length of the B portion of the round output. The step also determines whether T_L or T_R will be used as W in step 4ii.
 - 4.ii The bits of B are reversed, then $\text{NUM}_{radix}(B)$ produces a 12-byte numeral string in base $radix$; the results are again reversed. A 32-bit encoding of the round number i is stored in a 4-byte unit, which is reversed and then XORed with W . P is formed by concatenating these two results to form a 16-byte block.
 - 4.iii P is encrypted using the encryption key K to yield Y .
 - 4.iv This is similar to step 5.iv in FF1, except that Y is reversed before converting it into a numeral string in base 2.
 - 4.v The numerical values of the reverse of A and y are added modulo $radix^m$. This truncates the value of the sum to a value c that can be stored in m characters.
 - 4.vi This step converts c to a numeral string C .

The remaining steps are the same as for FF1.

7.9 KEY TERMS, REVIEW QUESTIONS, AND PROBLEMS

Key Terms

block cipher modes of operation ciphertext stealing	meet-in-the-middle attack nonce triple DES (3DES)	Tweakable block cipher
--	---	------------------------

Review Questions

- 7.1 What is a tweakable block cipher?
- 7.2 Why does double encryption of a plaintext with DES, with two different keys of 56 bits, not provide 112 bits of security?
- 7.3 Why is double encryption in DES with two different keys not likely to be equivalent to single encryption with a different key?
- 7.4 List and briefly define the block cipher modes of operation.
- 7.5 Why is the ECB mode not secure for encrypting large amounts of data or structured data?

Problems

- 7.1 You want to build a hardware device to do block encryption in the cipher block chaining (CBC) mode using an algorithm stronger than DES. 3DES is a good candidate. Figure 7.17 shows two possibilities, both of which follow from the definition of CBC. Which of the two would you choose:
 - a. For security?
 - b. For performance?
- 7.2 Can you suggest a security improvement to either option in Figure 7.17, using only three DES chips and some number of XOR functions? Assume you are still limited to two keys.

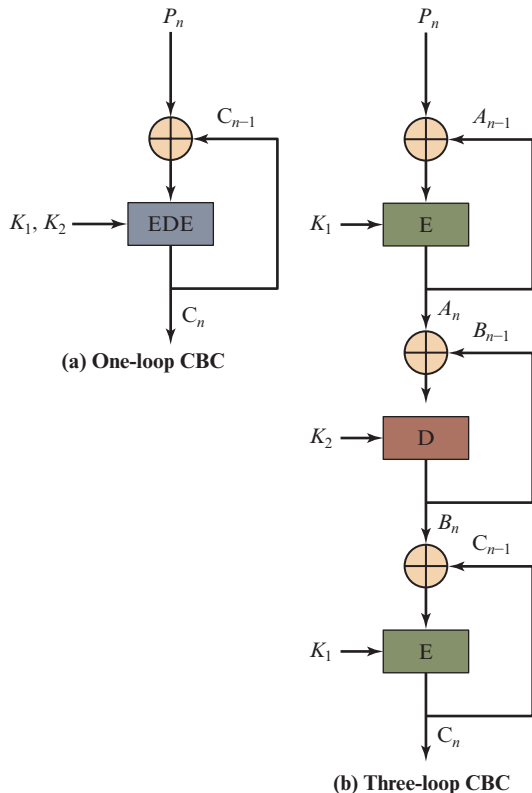

Figure 7.17 Use of Triple DES in CBC Mode

- 7.3** The Merkle–Hellman attack on 3DES begins by assuming a value of $A = 0$ (Figure 7.1b). Then, for each of the 2^{56} possible values of K_1 , the plaintext P that produces $A = 0$ is determined. Describe the rest of the algorithm.
- 7.4** With the ECB mode, if there is an error in a block of the transmitted ciphertext, only the corresponding plaintext block is affected. However, in the CBC mode, this error propagates. For example, an error in the transmitted C_1 (Figure 7.4) obviously corrupts P_1 and P_2 .
- Are any blocks beyond P_2 affected?
 - Suppose that there is a bit error in the source version of P_1 . Through how many ciphertext blocks is this error propagated? What is the effect at the receiver?
- 7.5** Why should the initialization vector be protected against unauthorised use in the CBC mode of encryption?
- 7.6** By the end of the 1970s, it was already realized by practitioners of cryptography that a *DES* key size of 56 bits was small enough to permit brute-force key search attacks by adversaries having enough hardware. A proposal to increase the key size of a modified version of *DES* (potentially to 184 bits) was made by Rivest in 1984. The method is known as *DESX* and encrypts a message m with keys k_1 , k_2 , and k_3 of size 64, 56, and 64 bits, respectively, as follows: $DES-X(k_1, k_2, k_3, m) = k_1 \oplus DES(k_2, m \oplus k_3)$. Show that it only gives a security of 120 bits against key search when the attacker has a few pairs of plaintext-ciphertext available. In fact, due to this attack, Rivest suggested keeping $k_1 = k_3$ with a security level of 120 bits.
- 7.7** Given n blocks of message, the ECB mode produces exactly n blocks of ciphertext. However, the CBC mode produces $(n + 1)$ blocks, due to the use of IV. Other modes such as CFB, OFB, and CTR also use an IV to encrypt messages. Show that secure encryption of multiple blocks of plaintext necessarily requires the use of IV (or some other form of randomization in the encryption process).
- 7.8** If a block of ciphertext gets corrupted during transmission in the OFB mode, how does it affect the decryption?
- 7.9** Is it possible to parallelize encryption in the CFB mode? What about decryption?
- 7.10** What are the advantages of CTR mode over the CBC mode? Explain in terms of the implementation benefits in software, hardware, and decryption throughput.
- 7.11** Padding may not always be appropriate. For example, one might wish to store the encrypted data in the same memory buffer that originally contained the plaintext. In that case, the ciphertext must be the same length as the original plaintext. We saw the use of ciphertext stealing in the case of XTS-AES to deal with partial blocks. Figure 7.18a shows the use of ciphertext stealing to modify CBC mode, called CBC-CTS.
- Explain how it works.
 - Describe how to decrypt C_{n-1} and C_n .
- 7.12** Figure 7.18b shows an alternative to CBC-CTS for producing ciphertext of equal length to the plaintext when the plaintext is not an integer multiple of the block size.
- Explain the algorithm.
 - Explain why CBC-CTS is preferable to this approach illustrated in Figure 7.18b.
- 7.13** Draw a figure similar to those of Figure 7.8 for XTS-AES mode.
- 7.14** Work out the following problems from first principles without converting to binary and counting the bits. Then, compare with the formulae presented for encoding a

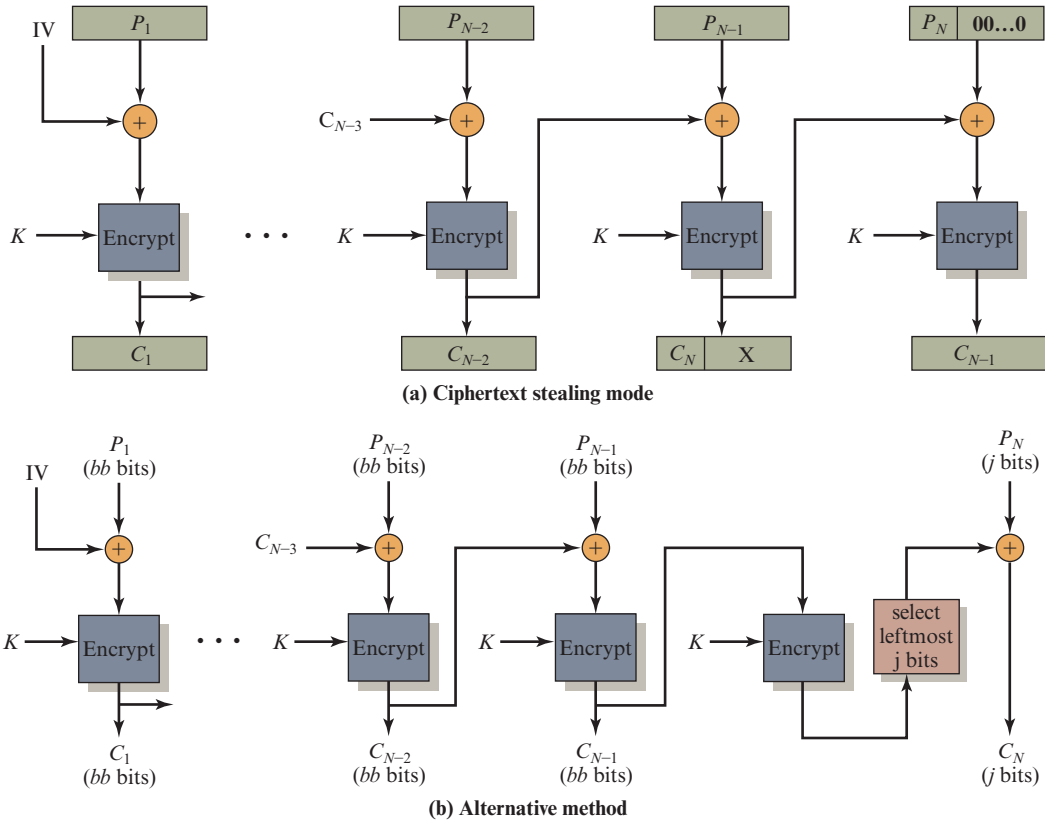

Figure 7.18 Block Cipher Modes for Plaintext not a Multiple of Block Size

character string into an integer, and vice-versa, in the specified radix. (*Hint*: Consider the next-lower and next-higher power of two for each integer.)

a. How many bits are exactly required to encode the following integers? (The number shown as an integer’s subscript refers to the radix of that integer.)

- i.** 2047_{10}
- ii.** 2048_{10}
- iii.** 32767_{10}
- iv.** 32768_{10}
- v.** 32767_{16}
- vi.** 32768_{16}
- vii.** $537F_{16}$
- viii.** 29431_{10}

b. Exactly how many bytes are required to represent the numbers in (a) above?

7.15 a. In radix-26, write down the numeral string X for each of the following character strings, followed by the number of “digits” (i.e., the length of the numeral string) in each case.

- i.** “hex”
- ii.** “cipher”
- iii.** “not”
- iv.** “symbol”

- b. For each case of problem (a), determine the number $x = \text{NUM}_{26}(X)$
 - c. Determine the byte form $[x]$ for each number x computed in problem (b).
 - d. What is the smallest power of the radix (26) that is greater than each of the numerical strings determined in (b)?
 - e. Is it related to the length of the numeral string in each case, in problem (a)? If so, what is this relationship?
- 7.16** Refer to algorithms FF1 and FF2.
- a. For step 1, for each algorithm, $u \leftarrow \lfloor n/2 \rfloor$ and $v \leftarrow \lceil n - u \rceil$. Show that for any three integers x, y , and n :
 - if $x = \lfloor n/2 \rfloor$ and $y = \lceil n - x \rceil$, then:
 - i. Either $x = n/2$, or $x = (n - 1)/2$.
 - ii. Either $y = n/2$, or $y = (n + 1)/2$.
 - iii. $x \leq y$. (Under what condition is $x = y$?)
 - b. What is the significance of result in the previous sub-problem (iii), in terms of the lengths u and v of the left and right half-strings, respectively?
- 7.17** In step 3 of Algorithm FF1, what do b and d represent? What is the unit of measurement (bits, bytes, digits, characters) of each of these quantities?
- 7.18** In the inputs to algorithms FF1, FF2, and FF3, why are the specified radix ranges important? For example, why should $\text{radix} \in [0..2^8]$ for Algorithm FF2, or $\text{radix} \in [2..2^{16}]$ in the case of Algorithm FF3?

Programming Problems

- 7.1** Create software that can encrypt and decrypt in cipher block chaining mode using one of the following ciphers: affine modulo 256, Hill modulo 256, S-DES, DES.
Test data for S-DES using a binary initialization vector of 1010 1010. A binary plaintext of 0000 0001 0010 0011 encrypted with a binary key of 01111 11101 should give a binary plaintext of 1111 0100 0000 1011. Decryption should work correspondingly.
- 7.2** Create software that can encrypt and decrypt in 4-bit cipher feedback mode using one of the following ciphers: additive modulo 256, affine modulo 256, S-DES;
- or**
- 8-bit cipher feedback mode using one of the following ciphers: 2×2 Hill modulo 256. Test data for S-DES using a binary initialization vector of 1010 1011. A binary plaintext of 0001 0010 0011 0100 encrypted with a binary key of 01111 11101 should give a binary plaintext of 1110 1100 1111 1010. Decryption should work correspondingly.
- 7.3** Create software that can encrypt and decrypt in counter mode using one of the following ciphers: affine modulo 256, Hill modulo 256, S-DES.
Test data for S-DES using a counter starting at 0000 0000. A binary plaintext of 0000 0001 0000 0010 0000 0100 encrypted with a binary key of 01111 11101 should give a binary plaintext of 0011 1000 0100 1111 0011 0010. Decryption should work correspondingly.
- 7.4** Implement a differential cryptanalysis attack on 3-round S-DES.

CHAPTER 8

RANDOM BIT GENERATION AND STREAM CIPHERS

8.1 Principles of Pseudorandom Number Generation

- The Use of Random Numbers
- TRNGs, PRNGs, and PRFs
- PRNG Requirements
- Algorithm Design

8.2 Pseudorandom Number Generators

- Linear Congruential Generators
- Blum Blum Shub Generator

8.3 Pseudorandom Number Generation Using a Block Cipher

- PRNG Using Block Cipher Modes of Operation
- NIST CTR_DRBG

8.4 Stream Ciphers

8.5 RC4

- Initialization of S
- Stream Generation
- Strength of RC4

8.6 Stream Ciphers Using Feedback Shift Registers

- Linear Feedback Shift Registers
- Nonlinear Feedback Shift Registers
- Grain-128a

8.7 True Random Number Generators

- Entropy Sources
- Comparison of PRNGs and TRNGs
- Conditioning
- Health Testing
- Intel Digital Random Number Generator

8.8 Key Terms, Review Questions, and Problems

LEARNING OBJECTIVES

After studying this chapter, you should be able to:

- ◆ Explain the concepts of randomness and unpredictability with respect to random numbers.
- ◆ Understand the differences among true random number generators, pseudorandom number generators, and pseudorandom functions.
- ◆ Present an overview of requirements for pseudorandom number generators.
- ◆ Explain how a block cipher can be used to construct a pseudorandom number generator.
- ◆ Present an overview of stream ciphers and RC4.
- ◆ Explain the significance of skew.

An important cryptographic function is the generation of random bit streams. Random bits streams are used in a wide variety of contexts, including key generation and encryption. In essence, there are two fundamentally different strategies for generating random bits or random numbers. One strategy, which until recently dominated in cryptographic applications, computes bits deterministically using an algorithm. This class of random bit generators is known as pseudorandom number generators (PRNGs) or deterministic random bit generators (DRBGs). The other strategy is to produce bits non-deterministically using some physical source that produces some sort of random output. This latter class of random bit generators is known as true random number generators (TRNGs) or non-deterministic random bit generators (NRBGs).

The chapter begins with an analysis of the basic principles of PRNGs. Next, we look at some common PRNGs, including PRNGs based on the use of a symmetric block cipher. The chapter then moves on to the topic of symmetric stream ciphers, which are based on the use of a PRNG.

The remainder of the chapter is devoted to TRNGs. We look first at the basic principles and structure of TRNGs, and then examine a specific product, the Intel Digital Random Number Generator.

Throughout this chapter, reference is made to four important NIST documents:

- SP 800-90A (*Recommendation for Random Number Generation Using Deterministic Random Bit Generators*, June 2015): Specifies mechanisms for the generation of random bits using deterministic methods.
- SP 800-90B (*Recommendation for the Entropy Sources Used for Random Bit Generation*, January 2018): Covers design principles and requirements for entropy sources (ES), the devices from which we get unpredictable randomness and NRNGs.
- SP 800-90C (*Recommendation for Random Bit Generator (RBG) Constructions*, April 2016): Discusses how to combine the entropy sources in 90B with the DRNG's from 90A to provide large quantities of unpredictable bits for cryptographic applications.

- SP 800-22 (*A Statistical Test Suite for Random and Pseudorandom Number Generators for Cryptographic Applications*, April 2010) discusses the selection and testing of NRBGs and DRBGs.

These specifications have heavily influenced the implementation of random bit generators in industry both in the U.S. and worldwide.

8.1 PRINCIPLES OF PSEUDORANDOM NUMBER GENERATION

Random numbers play an important role in the use of encryption for various network security applications. In this section, we provide a brief overview of the use of random numbers in cryptography and network security and then focus on the principles of pseudorandom number generation.

The Use of Random Numbers

A number of network security algorithms and protocols based on cryptography make use of random binary numbers. For example,

- Key distribution and reciprocal (mutual) authentication schemes, such as those discussed in Chapters 14 and 15. In such schemes, two communicating parties cooperate by exchanging messages to distribute keys and/or authenticate each other. In many cases, nonces are used for handshaking to prevent replay attacks. The use of random numbers for the nonces frustrates an opponent's efforts to determine or guess the nonce, in order to repeat an obsolete transaction.
- Session key generation. We will see a number of protocols in this book where a secret key for symmetric encryption is generated for use for a particular transaction (or session) and is valid for a short period of time. This key is generally called a session key.
- Generation of keys for the RSA public-key encryption algorithm (described in Chapter 9).
- Generation of a bit stream for symmetric stream encryption (described in this chapter).

These applications give rise to two distinct and not necessarily compatible requirements for a sequence of random numbers: randomness and **unpredictability**.

RANDOMNESS Traditionally, the concern in the generation of a sequence of allegedly random numbers has been that the sequence of numbers be random in some well-defined statistical sense. The following two criteria are used to validate that a sequence of numbers is random:

- **Uniform distribution:** The distribution of bits in the sequence should be uniform; that is, the frequency of occurrence of ones and zeros should be approximately equal.
- **Independence:** No one subsequence in the sequence can be inferred from the others.

Although there are well-defined tests for determining that a sequence of bits matches a particular distribution, such as the uniform distribution, there is no such test to “prove” independence. Rather, a number of tests can be applied to demonstrate if a sequence does not exhibit independence. The general strategy is to apply a number of such tests until the confidence that independence exists is sufficiently strong. That is, if each of a number of tests fails to show that a sequence of bits is not independent, then we can have a high level of confidence that the sequence is in fact independent.

In the context of our discussion, the use of a sequence of numbers that appear statistically random often occurs in the design of algorithms related to cryptography. For example, a fundamental requirement of the RSA public-key encryption scheme discussed in Chapter 9 is the ability to generate prime numbers. In general, it is difficult to determine if a given large number N is prime. A brute-force approach would be to divide N by every odd integer less than \sqrt{N} . If N is on the order, say, of 10^{150} , which is a not uncommon occurrence in public-key cryptography, such a brute-force approach is beyond the reach of human analysts and their computers. However, a number of effective algorithms exist that test the primality of a number by using a sequence of randomly chosen integers as input to relatively simple computations. If the sequence is sufficiently long (but far, far less than $\sqrt{10^{150}}$), the primality of a number can be determined with near certainty. This type of approach, known as randomization, crops up frequently in the design of algorithms. In essence, if a problem is too hard or time-consuming to solve exactly, a simpler, shorter approach based on randomization is used to provide an answer with any desired level of confidence.

UNPREDICTABILITY In applications such as reciprocal authentication, session key generation, and stream ciphers, the requirement is not just that the sequence of numbers be statistically random but that the successive members of the sequence are unpredictable. With “true” random sequences, each number is statistically independent of other numbers in the sequence and therefore unpredictable. Although true random numbers are used in some applications, they have their limitations, such as inefficiency, as is discussed shortly. Thus, it is more common to implement algorithms that generate sequences of numbers that appear to be random but are in fact not random. In this latter case, care must be taken that an opponent not be able to predict future elements of the sequence on the basis of earlier elements.

TRNGs, PRNGs, and PRFs

Cryptographic applications typically make use of algorithmic techniques for random number generation. These algorithms are deterministic and therefore produce sequences of numbers that are not statistically random. However, if the algorithm is good, the resulting sequences will pass many tests of randomness. Such numbers are referred to as pseudorandom numbers.

You may be somewhat uneasy about the concept of using numbers generated by a deterministic algorithm as if they were random numbers. Despite what might be called philosophical objections to such a practice, it generally works. That is, under most circumstances, pseudorandom numbers will perform as well as if they were random for a given use. The phrase “as well as” is unfortunately subjective, but the

- **Pseudorandom function (PRF):** A PRF is used to produce a pseudorandom string of bits of some fixed length. Examples are symmetric encryption keys and nonces. Typically, the PRF takes as input a seed plus some context specific values, such as a user ID or an application ID. A number of examples of PRFs will be seen throughout this book, notably in Chapters 19 and 20.

Other than the number of bits produced, there is no difference between a PRNG and a PRF. The same algorithms can be used in both applications. Both require a seed and both must exhibit randomness and unpredictability. Further, a PRNG application may also employ context-specific input. In what follows, we make no distinction between these two applications.

PRNG Requirements

When a PRNG or PRF is used for a cryptographic application, then the basic requirement is that an adversary who does not know the seed is unable to determine the pseudorandom string. For example, if the pseudorandom bit stream is used in a stream cipher, then knowledge of the pseudorandom bit stream would enable the adversary to recover the plaintext from the ciphertext. Similarly, we wish to protect the output value of a PRF. In this latter case, consider the following scenario. A 128-bit seed, together with some context-specific values, are used to generate a 128-bit secret key that is subsequently used for symmetric encryption. Under normal circumstances, a 128-bit key is safe from a brute-force attack. However, if the PRF does not generate effectively random 128-bit output values, it may be possible for an adversary to narrow the possibilities and successfully use a brute force attack.

This general requirement for secrecy of the output of a PRNG or PRF leads to specific requirements in the areas of randomness, unpredictability, and the characteristics of the seed. We now look at these in turn.

RANDOMNESS In terms of randomness, the requirement for a PRNG is that the generated bit stream appear random even though it is deterministic. There is no single test that can determine if a PRNG generates numbers that have the characteristic of randomness. The best that can be done is to apply a sequence of tests to the PRNG. If the PRNG exhibits randomness on the basis of multiple tests, then it can be assumed to satisfy the randomness requirement. NIST SP 800-22 specifies that the tests should seek to establish the following three characteristics.

- **Uniformity:** At any point in the generation of a sequence of random or pseudorandom bits, the occurrence of a zero or one is equally likely, that is, the probability of each is exactly $1/2$. The expected number of zeros (or ones) is $n/2$, where n = the sequence length.
- **Scalability:** Any test applicable to a sequence can also be applied to subsequences extracted at random. If a sequence is random, then any such extracted subsequence should also be random. Hence, any extracted subsequence should pass any test for randomness.
- **Consistency:** The behavior of a generator must be consistent across starting values (seeds). It is inadequate to test a PRNG based on the output from a single seed or a TRNG on the basis of an output produced from a single physical output.

SP 800-22 lists 15 separate tests of randomness. An understanding of these tests requires a basic knowledge of statistical analysis, so we don't attempt a technical description here. Instead, to give some flavor for the tests, we list three of the tests and the purpose of each test, as follows.

- **Frequency test:** This is the most basic test and must be included in any test suite. The purpose of this test is to determine whether the number of ones and zeros in a sequence is approximately the same as would be expected for a truly random sequence.
- **Runs test:** The focus of this test is the total number of runs in the sequence, where a run is an uninterrupted sequence of identical bits bounded before and after with a bit of the opposite value. The purpose of the runs test is to determine whether the number of runs of ones and zeros of various lengths is as expected for a random sequence.
- **Maurer's universal statistical test:** The focus of this test is the number of bits between matching patterns (a measure that is related to the length of a compressed sequence). The purpose of the test is to detect whether or not the sequence can be significantly compressed without loss of information. A significantly compressible sequence is considered to be non-random.

UNPREDICTABILITY A stream of pseudorandom numbers should exhibit two forms of unpredictability:

- **Forward unpredictability:** If the seed is unknown, the next output bit in the sequence should be unpredictable in spite of any knowledge of previous bits in the sequence.
- **Backward unpredictability:** It should also not be feasible to determine the seed from knowledge of any generated values. No correlation between a seed and any value generated from that seed should be evident; each element of the sequence should appear to be the outcome of an independent random event whose probability is 1/2.

The same set of tests for randomness also provide a test of unpredictability. If the generated bit stream appears random, then it is not possible to predict some bit or bit sequence from knowledge of any previous bits. Similarly, if the bit sequence appears random, then there is no feasible way to deduce the seed based on the bit sequence. That is, a random sequence will have no correlation with a fixed value (the seed).

SEED REQUIREMENTS For cryptographic applications, the seed that serves as input to the PRNG must be secure. Because the PRNG is a deterministic algorithm, if the adversary can deduce the seed, then the output can also be determined. Therefore, the seed must be unpredictable. In fact, the seed itself must be a random or pseudorandom number.

Typically, the seed is generated by a TRNG, as shown in Figure 8.2. This is the scheme recommended by SP 800-90A. The reader may wonder, if a TRNG is available, why it is necessary to use a PRNG. If the application is a stream cipher, then a TRNG is not practical. The sender would need to generate a keystream of

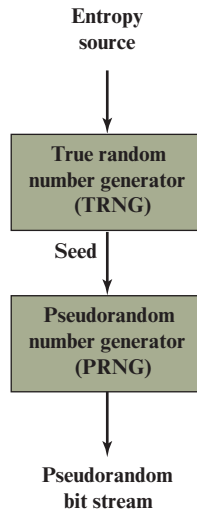

Figure 8.2 Generation of Seed Input to PRNG

bits as long as the plaintext and then transmit the keystream and the ciphertext securely to the receiver. If a PRNG is used, the sender need only find a way to deliver the stream cipher key, which is typically 128 or 256 bits, to the receiver in a secure fashion.

Even in the case of a PRF application, in which only a limited number of bits is generated, it is generally desirable to use a TRNG to provide the seed to the PRF and use the PRF output rather than use the TRNG directly. As is explained in Section 8.6, a TRNG may produce a binary string with some bias. The PRF would have the effect of conditioning the output of the TRNG so as to eliminate that bias.

Finally, the mechanism used to generate true random numbers may not be able to generate bits at a rate sufficient to keep up with the application requiring the random bits.

Algorithm Design

Cryptographic PRNGs have been the subject of much research over the years, and a wide variety of algorithms have been developed. These fall roughly into two categories.

- **Purpose-built algorithms:** These are algorithms designed specifically and solely for the purpose of generating pseudorandom bit streams. Some of these algorithms are used for a variety of PRNG applications; several of these are described in the next section. Others are designed specifically for use in a stream cipher. This topic is examined later in this chapter.
- **Algorithms based on existing cryptographic algorithms:** Cryptographic algorithms have the effect of randomizing input data. Indeed, this is a requirement of such algorithms. For example, if a symmetric block cipher produced

ciphertext that had certain regular patterns in it, it would aid in the process of cryptanalysis. Thus, cryptographic algorithms can serve as the core of PRNGs. SP 800-90A recommends three categories of such algorithms:

- Symmetric block ciphers:** This approach is discussed in Section 8.3.
- Hash functions and message authentication codes:** These approaches are examined in Chapter 12.

Any of these approaches can yield a cryptographically strong PRNG. A purpose-built algorithm may be provided by an operating system for general use. For applications that already use certain cryptographic algorithms for encryption or authentication, it makes sense to reuse the same code for the PRNG. Thus, all of these approaches are in common use.

8.2 PSEUDORANDOM NUMBER GENERATORS

In this section, we look at two types of algorithms for PRNGs.

Linear Congruential Generators

A widely used technique for pseudorandom number generation is an algorithm first proposed by Lehmer [LEHM51], which is known as the linear congruential method. The algorithm is parameterized with four numbers, as follows:

m	the modulus	$m > 0$
a	the multiplier	$0 < a < m$
c	the increment	$0 \leq c < m$
X_0	the starting value, or seed	$0 \leq X_0 < m$

The sequence of random numbers $\{X_n\}$ is obtained via the following iterative equation:

$$X_{n+1} = (aX_n + c) \bmod m$$

If m , a , c , and X_0 are integers, then this technique will produce a sequence of integers with each integer in the range $0 \leq X_n < m$.

The selection of values for a , c , and m is critical in developing a good random number generator. For example, consider $a = c = 1$. The sequence produced is obviously not satisfactory. Now consider the values $a = 7$, $c = 0$, $m = 32$, and $X_0 = 1$. This generates the sequence $\{7, 17, 23, 1, 7, \text{etc.}\}$, which is also clearly unsatisfactory. Of the 32 possible values, only four are used; thus, the sequence is said to have a period of 4. If, instead, we change the value of a to 5, then the sequence is $\{5, 25, 29, 17, 21, 9, 13, 1, 5, \text{etc.}\}$, which increases the period to 8.

We would like m to be very large, so that there is the potential for producing a long series of distinct random numbers. A common criterion is that m be nearly equal to the maximum representable nonnegative integer for a given computer. Thus, a value of m near to or equal to 2^{31} is typically chosen.

[PARK88] proposes three tests to be used in evaluating a random number generator:

- T₁: The function should be a full-period generating function. That is, the function should generate all the numbers from 0 through $m - 1$ before repeating.
- T₂: The generated sequence should appear random.
- T₃: The function should implement efficiently with 32-bit arithmetic.

With appropriate values of a , c , and m , these three tests can be passed. With respect to T₁, it can be shown that if m is prime and $c = 0$, then for certain values of a the period of the generating function is $m - 1$, with only the value 0 missing. For 32-bit arithmetic, a convenient prime value of m is $2^{31} - 1$. Thus, the generating function becomes

$$X_{n+1} = (aX_n) \bmod (2^{31} - 1)$$

Of the more than 2 billion possible choices for a , only a handful of multipliers pass all three tests. One such value is $a = 7^5 = 16807$, which was originally selected for use in the IBM 360 family of computers [LEWI69]. This generator is widely used and has been subjected to a more thorough testing than any other PRNG. It is frequently recommended for statistical and simulation work (e.g., [JAIN91]).

The strength of the linear congruential algorithm is that if the multiplier and modulus are properly chosen, the resulting sequence of numbers will be statistically indistinguishable from a sequence drawn at random (but without replacement) from the set $1, 2, \dots, m - 1$. But there is nothing random at all about the algorithm, apart from the choice of the initial value X_0 . Once that value is chosen, the remaining numbers in the sequence follow deterministically. This has implications for cryptanalysis.

If an opponent knows that the linear congruential algorithm is being used and if the parameters are known (e.g., $a = 7^5$, $c = 0$, $m = 2^{31} - 1$), then once a single number is discovered, all subsequent numbers are known. Even if the opponent knows only that a linear congruential algorithm is being used, knowledge of a small part of the sequence is sufficient to determine the parameters of the algorithm. Suppose that the opponent is able to determine values for X_0 , X_1 , X_2 , and X_3 . Then

$$\begin{aligned} X_1 &= (aX_0 + c) \bmod m \\ X_2 &= (aX_1 + c) \bmod m \\ X_3 &= (aX_2 + c) \bmod m \end{aligned}$$

These equations can be solved for a , c , and m .

Thus, although it is nice to be able to use a good PRNG, it is desirable to make the actual sequence used nonreproducible, so that knowledge of part of the sequence on the part of an opponent is insufficient to determine future elements of the sequence. This goal can be achieved in a number of ways. For example, [BRIG79] suggests using an internal system clock to modify the random number stream. One way to use the clock would be to restart the sequence after every N numbers using the current clock value (mod m) as the new seed. Another way would be simply to add the current clock value to each random number (mod m).

Blum Blum Shub Generator

A popular approach to generating secure pseudorandom numbers is known as the Blum Blum Shub (BBS) generator (see Figure 8.3), named for its developers [BLUM86]. It has perhaps the strongest public proof of its cryptographic strength of any purpose-built algorithm. The procedure is as follows. First, choose two large prime numbers, p and q , that both have a remainder of 3 when divided by 4. That is,

$$p \equiv q \equiv 3(\text{mod } 4)$$

This notation, explained more fully in Chapter 2, simply means that $(p \text{ mod } 4) = (q \text{ mod } 4) = 3$. For example, the prime numbers 7 and 11 satisfy $7 \equiv 11 \equiv 3(\text{mod } 4)$. Let $n = p \times q$. Next, choose a random number s , such that s is relatively prime to n ; this is equivalent to saying that neither p nor q is a factor of s . Then the BBS generator produces a sequence of bits B_i according to the following algorithm:

$$\begin{aligned} X_0 &= s^2 \text{ mod } n \\ \text{for } i &= 1 \text{ to } \infty \\ X_i &= (X_{i-1})^2 \text{ mod } n \\ B_i &= X_i \text{ mod } 2 \end{aligned}$$

Thus, the least significant bit is taken at each iteration. Table 8.1 shows an example of BBS operation. Here, $n = 192649 = 383 \times 503$, and the seed $s = 101355$.

The BBS is referred to as a cryptographically secure pseudorandom bit generator (CSPRNG). A CSPRNG is defined as one that passes the *next-bit test*, which, in turn, is defined as follows [MENE97]: A pseudorandom bit generator is said to pass the next-bit test if there is not a polynomial-time algorithm¹ that, on input of the first k bits of an output sequence, can predict the $(k + 1)$ st bit with probability significantly greater than $1/2$. In other words, given the first k bits of the

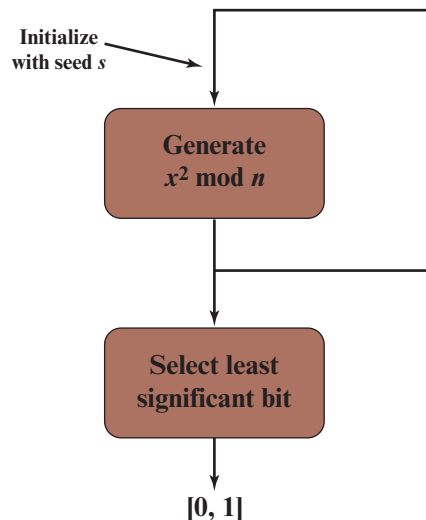

Figure 8.3 Blum Blum Shub Block Diagram

¹A polynomial-time algorithm of order k is one whose running time is bounded by a polynomial of order k .

Table 8.1 Example Operation of BBS Generator

i	X_i	B_i
0	20749	
1	143135	1
2	177671	1
3	97048	0
4	89992	0
5	174051	1
6	80649	1
7	45663	1
8	69442	0
9	186894	0
10	177046	0

i	X_i	B_i
11	137922	0
12	123175	1
13	8630	0
14	114386	0
15	14863	1
16	133015	1
17	106065	1
18	45870	0
19	137171	1
20	48060	0

sequence, there is not a practical algorithm that can even allow you to state that the next bit will be 1 (or 0) with probability greater than 1/2. For all practical purposes, the sequence is unpredictable. The security of BBS is based on the difficulty of factoring n . That is, given n , we need to determine its two prime factors p and q .

8.3 PSEUDORANDOM NUMBER GENERATION USING A BLOCK CIPHER

A popular approach to PRNG construction is to use a symmetric block cipher as the heart of the PRNG mechanism. For any block of plaintext, a symmetric block cipher produces an output block that is apparently random. That is, there are no patterns or regularities in the ciphertext that provide information that can be used to deduce the plaintext. Thus, a symmetric block cipher is a good candidate for building a pseudorandom number generator.

If an established, standardized block cipher is used, such as DES or AES, then the security characteristics of the PRNG can be established. Further, many applications already make use of DES or AES, so the inclusion of the block cipher as part of the PRNG algorithm is straightforward.

PRNG Using Block Cipher Modes of Operation

Two approaches that use a block cipher to build a PRNG have gained widespread acceptance: the CTR mode and the OFB mode. The CTR mode is recommended in NIST SP 800-90A, in the ANSI standard X9.82 (*Random Number Generation*), and in RFC 4086 (*Randomness Requirements for Security*, June 2005). The OFB mode is recommended in X9.82 and RFC 4086.

Figure 8.4 illustrates the two methods. In each case, the seed consists of two parts: the encryption key value and a value V that will be updated after each block of pseudorandom numbers is generated. Thus, for AES-128, the seed consists of a 128-bit key and a 128-bit V value. In the CTR case, the value of V is incremented

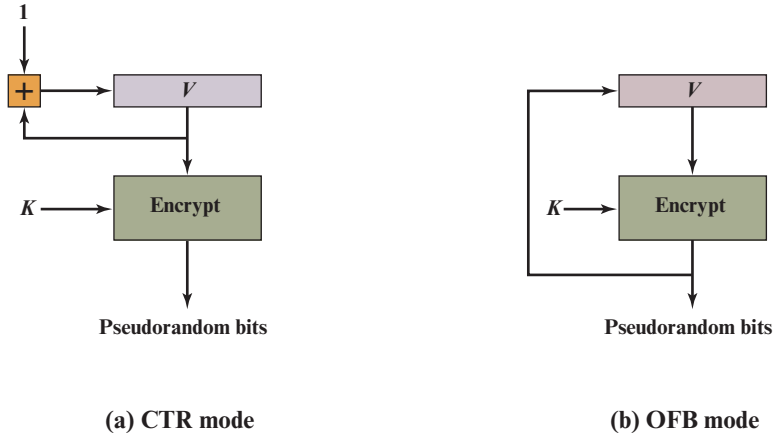

Figure 8.4 PRNG Mechanisms Based on Block Ciphers

by 1 after each encryption. In the case of OFB, the value of V is updated to equal the value of the preceding PRNG block. In both cases, pseudorandom bits are produced one block at a time (e.g., for AES, PRNG bits are generated 128 bits at a time).

The CTR algorithm for PRNG, called CTR_DRBG, can be summarized as follows.

```

while (len (temp) < requested_number_of_bits) do
    V = (V + 1) mod 2128
    output_block = E(Key, V)
    temp = temp || output_block
    
```

The OFB algorithm can be summarized as follows.

```

while (len (temp) < requested_number_of_bits) do
    V = E(Key, V)
    temp = temp || V
    
```

To get some idea of the performance of these two PRNGs, consider the following short experiment. A random bit sequence of 256 bits was obtained from random.org, which uses three radios tuned between stations to pick up atmospheric noise. These 256 bits form the seed, allocated as

Key:	cfb0ef3108d49cc4562d5810b0a9af60
V:	4c89af496176b728ed1e2ea8ba27f5a4

The total number of one bits in the 256-bit seed is 124, or a fraction of 0.48, which is reassuringly close to the ideal of 0.5.

For the OFB PRNG, Table 8.2 shows the first eight output blocks (1024 bits) with two rough measures of security. The second column shows the fraction of one bits in each 128-bit block. This corresponds to one of the NIST tests. The results indicate that the output is split roughly equally between zero and one bits. The third column shows the fraction of bits that match between adjacent blocks. If this number

Table 8.2 Example Results for PRNG Using OFB

Output Block	Fraction of One Bits	Fraction of Bits that Match with Preceding Block
1786f4c7ff6e291dbdfdd90ec3453176	0.57	—
5e17b22b14677a4d66890f87565eae64	0.51	0.52
fd18284ac82251dfb3aa62c326cd46cc	0.47	0.54
c8e545198a758ef5dd86b41946389bd5	0.50	0.44
fe7bae0e23019542962e2c52d215a2e3	0.47	0.48
14fdf5ec99469598ae0379472803accd	0.49	0.52
6aeca972e5a3ef17bd1a1b775fc8b929	0.57	0.48
f7e97badf359d128f00d9b4ae323db64	0.55	0.45

Table 8.3 Example Results for PRNG Using CTR

Output Block	Fraction of One Bits	Fraction of Bits that Match with Preceding Block
1786f4c7ff6e291dbdfdd90ec3453176	0.57	—
60809669a3e092a01b463472fdcae420	0.41	0.41
d4e6e170b46b0573eedf88ee39bff33d	0.59	0.45
5f8fcfc5deca18ea246785d7fadc76f8	0.59	0.52
90e63ed27bb07868c753545bdd57ee28	0.53	0.52
0125856fdf4a17f747c7833695c52235	0.50	0.47
f4be2d179b0f2548fd748c8fc7c81990	0.51	0.48
1151fc48f90eebac658a3911515c3c66	0.47	0.45

differs substantially from 0.5, that suggests a correlation between blocks, which could be a security weakness. The results suggest no correlation.

Table 8.3 shows the results using the same key and V values for CTR mode. Again, the results are favorable.

NIST CTR_DRBG

We now look more closely at the details of the PRNG defined in NIST SP 800-90A based on the CTR mode of operation. The PRNG is referred to as CTRDRBG (counter mode–deterministic random bit generator). CTR_DRBG is widely implemented and is part of the hardware random number generator implemented on all recent Intel processor chips (discussed in Section 8.6).

The DRBG assumes that an entropy source is available to provide random bits. Typically, the entropy source will be a TRNG based on some physical source. Other sources are possible if they meet the required entropy measure of the application. Entropy is an information theoretic concept that measures unpredictability, or randomness; see Appendix B for details. The encryption algorithm used in the DRBG may be 3DES with three keys or AES with a key size of 128, 192, or 256 bits.

Table 8.4 CTR_DRBG Parameters

	3DES	AES-128	AES-192	AES-256
<i>outlen</i>	64	128	128	128
<i>keylen</i>	168	128	192	256
<i>seedlen</i>	232	256	320	384
<i>reseed_interval</i>	$\leq 2^{32}$	$\leq 2^{48}$	$\leq 2^{48}$	$\leq 2^{48}$

Four parameters are associated with the algorithm:

- **Output block length** (*outlen*): Length of the output block of the encryption algorithm.
- **Key length** (*keylen*): Length of the encryption key.
- **Seed length** (*seedlen*): The seed is a string of bits that is used as input to a DRBG mechanism. The seed will determine a portion of the internal state of the DRBG, and its entropy must be sufficient to support the security strength of the DRBG. $seedlen = outlen + keylen$.
- **Reseed interval** (*reseed_interval*): Length of the encryption key. It is the maximum number of output blocks generated before updating the algorithm with a new seed.

Table 8.4 lists the values specified in SP 800-90A for these parameters.

INITIALIZE Figure 8.5 shows the two principal functions that comprise CTR_DRBG. We first consider how CTR_DRBG is initialized, using the initialize and update function (Figure 8.5a). Recall that the CTR block cipher mode requires both an encryption key K and an initial counter value, referred to in SP 800-90A as the counter V . The combination of K and V is referred to as the *seed*. To start the DRBG operation, initial values for K and V are needed, and can be chosen arbitrarily. As an example, the Intel Digital Random Number Generator, discussed in Section 8.6, uses the values $K = 0$ and $V = 0$. These values are used as parameters for the CTR mode of operation to produce at least *seedlen* bits. In addition, exactly *seedlen* bits must be supplied from what is referred to as an *entropy source*. Typically, the entropy source would be some form of TRNG.

With these inputs, the CTR mode of encryption is iterated to produce a sequence of output blocks, with V incremented by 1 after each encryption. The process continues until at least *seedlen* bits have been generated. The leftmost *seedlen* bits of output are then XORed with the *seedlen* entropy bits to produce a new seed. In turn, the leftmost *keylen* bits of the seed form the new key and the rightmost *outlen* bits of the seed form the new counter value V .

GENERATE Once values of Key and V are obtained, the DRBG enters the generate phase and is able to generate pseudorandom bits, one output block at a time (Figure 8.5b). The encryption function is iterated to generate the number of pseudorandom bits desired. Each iteration uses the same encryption key. The counter value V is incremented by 1 for each iteration.

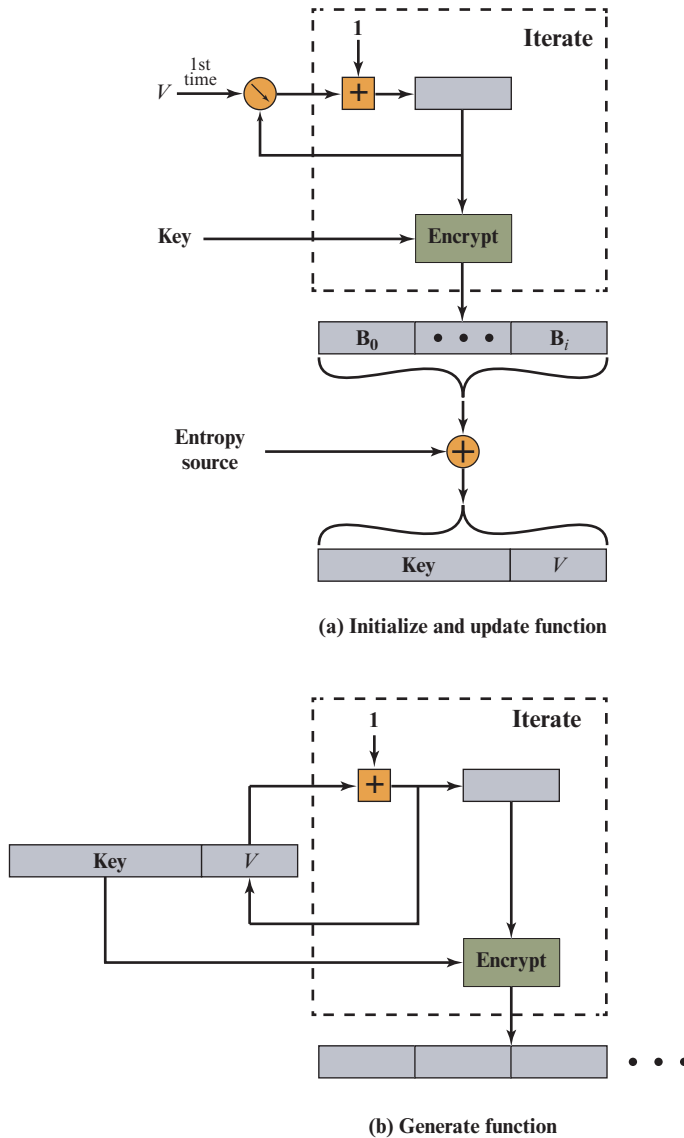

Figure 8.5 CTR_DRBG Functions

UPDATE To enhance security, the number of bits generated by any PRNG should be limited. CTR_DRBG uses the parameter *reseed_interval* to set that limit. During the generate phase, a reseed counter is initialized to 1 and then incremented with each iteration (each production of an output block). When the reseed counter reaches *reseed_interval*, the update function is invoked (Figure 8.5a). The update function is the same as the initialize function. In the update case, the Key and V values last used by the generate function serve as the input parameters to the update function. The update function takes *seedlen* new bits from an entropy source and produces a new seed (Key, V). The generate function can then resume production of pseudorandom

bits. Note that the result of the update function is to change both the Key and V values used by the generate function.

8.4 STREAM CIPHERS

Stream ciphers can be viewed a pseudorandom equivalent of a one-time pad. The one-time pad uses a long random key, of length equal to the plaintext message. A stream cipher uses a short secret key and a pseudorandomly generated stream of bits, computationally indistinguishable from a stream of random digits. Traditionally, block ciphers have been more widely used, in a greater range of applications. This is primarily due to the ability of block ciphers to easily be used in a variety of ways using different modes of operation. In addition, block ciphers can be used as stream ciphers via modes of operation such as Counter, OFB, and CBC.

In recent years, there has been a resurgence of interest in the use of stream ciphers [BIRY04]. Stream ciphers are useful when there is a need to encrypt large amounts of fast streaming data. And stream ciphers are well suited to use in devices with very limited memory and processing power, called **constrained devices**. Examples include small wireless sensors as part of an Internet of Things (IoT) and radio frequency identification (RFID) tags.

Figure 8.6 shows the structure of a typical stream cipher. There are three internal elements. There is a secret **state** s_i (i.e., memory) that evolves with time during encryption and decryption; the initial state is designated as s_0 . A **state transition function** f , at each bit generation time, computes a new state value from the old state value. An **output function** g produces the stream of bits used for encryption and decryption, known as the **keystream** z_i . A secret key K provides input to the stream cipher, and is used to initialize the state. K may also serve as an input parameter to f . Some stream ciphers also include an initialization vector IV that is

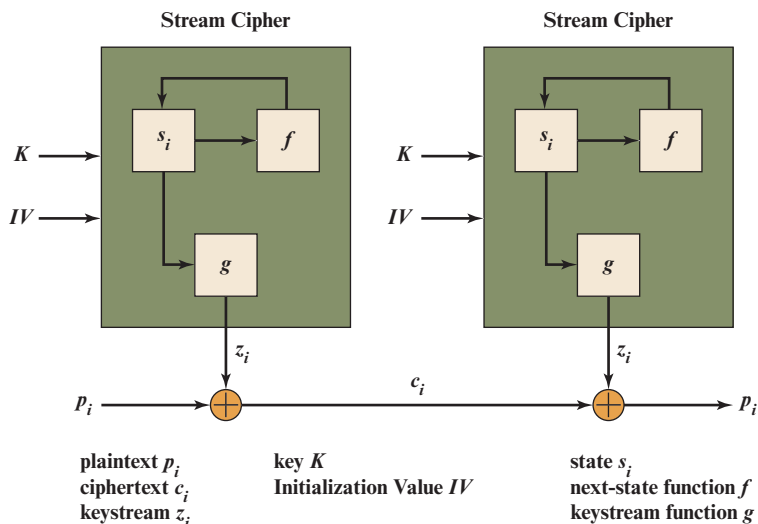

Figure 8.6 Generic Structure of a Typical Stream Cipher

used, along with K , to initialize the state. As is the case for block ciphers, the IV for a stream cipher need not be secret. However, it should be unpredictable and unique.

The keystream is combined one byte at a time with the plaintext stream using the bitwise exclusive-OR (XOR) operation. For example, if the next byte generated by the generator is 01101100 and the next plaintext byte is 11001100, then the resulting ciphertext byte is

$$\begin{array}{r} 11001100 \text{ plaintext} \\ \oplus \underline{01101100} \text{ key stream} \\ \hline 10100000 \text{ ciphertext} \end{array}$$

Decryption requires the use of the same pseudorandom sequence:

$$\begin{array}{r} 10100000 \text{ ciphertext} \\ \oplus \underline{01101100} \text{ key stream} \\ \hline 11001100 \text{ plaintext} \end{array}$$

The stream cipher is similar to the one-time pad discussed in Chapter 3. The difference is that a one-time pad uses a genuine random number stream, whereas a stream cipher uses a pseudorandom number stream.

[KUMA97] lists the following important design considerations for a stream cipher.

1. The encryption sequence should have a large period. A pseudorandom number generator uses a function that produces a deterministic stream of bits that eventually repeats. The longer the period of repeat the more difficult it will be to do cryptanalysis. This is essentially the same consideration that was discussed with reference to the Vigenère cipher, namely that the longer the keyword the more difficult the cryptanalysis.
2. The keystream should approximate the properties of a true random number stream as close as possible. For example, there should be an approximately equal number of 1s and 0s. If the keystream is treated as a stream of bytes, then all of the 256 possible byte values should appear approximately equally often. The more random-appearing the keystream is, the more randomized the ciphertext is, making cryptanalysis more difficult.
3. Note from Figure 8.6 that the output of the pseudorandom number generator is conditioned on the value of the input key. To guard against brute-force attacks, the key needs to be sufficiently long. The same considerations that apply to block ciphers are valid here. Thus, with current technology, a key length of at least 128 bits is desirable.

With a properly designed pseudorandom number generator, a stream cipher can be as secure as a block cipher of comparable key length. A potential advantage of a stream cipher is that stream ciphers that do not use block ciphers as a building block are typically faster and use far less code than do block ciphers. The example in this chapter, RC4, can be implemented in just a few lines of code. In recent years, this advantage has diminished with the introduction of AES, which is quite efficient in software. Furthermore, hardware acceleration techniques are now available for AES. For example, the Intel AES Instruction Set has machine instructions for one round of encryption and decryption and key generation. Using the hardware instructions results in speedups of about an order of magnitude compared to pure software implementations [XU10].

One advantage of a block cipher is that you can reuse keys. In contrast, if two plaintexts are encrypted with the same key using a stream cipher, then cryptanalysis is often quite simple [DAWS96]. If the two ciphertext streams are XORed together, the result is the XOR of the original plaintexts. If the plaintexts are text strings, credit card numbers, or other byte streams with known properties, then cryptanalysis may be successful.

For applications that require encryption/decryption of a stream of data, such as over a data communications channel or a browser/Web link, a stream cipher might be the better alternative. For applications that deal with blocks of data, such as file transfer, email, and database, block ciphers may be more appropriate. However, either type of cipher can be used in virtually any application.

A stream cipher can be constructed with any cryptographically strong PRNG, such as the ones discussed in Sections 8.2 and 8.3. In the next section, we look at a stream cipher that uses a PRNG designed specifically for the stream cipher.

8.5 RC4

RC4 is a stream cipher designed in 1987 by Ron Rivest for RSA Security. It is a variable key size stream cipher with byte-oriented operations. The algorithm is based on the use of a random permutation. Analysis shows that the period of the cipher is overwhelmingly likely to be greater than 10^{100} [ROBS95a]. Eight to sixteen machine operations are required per output byte, and the cipher can be expected to run very quickly in software. RC4 is used in the WiFi Protected Access (WPA) protocol that are part of the IEEE 802.11 wireless LAN standard. It is optional for use in Secure Shell (SSH) and Kerberos. RC4 was kept as a trade secret by RSA Security. In September 1994, the RC4 algorithm was anonymously posted on the Internet on the Cypherpunks anonymous remailers list.

The RC4 algorithm is remarkably simple and quite easy to explain. A variable-length key of from 1 to 256 bytes (8 to 2048 bits) is used to initialize a 256-byte state vector S , with elements $S[0], S[1], \dots, S[255]$. At all times, S contains a permutation of all 8-bit numbers from 0 through 255. For encryption and decryption, a byte k is generated from S by selecting one of the 255 entries in a systematic fashion. As each value of k is generated, the entries in S are once again permuted.

Initialization of S

To begin, the entries of S are set equal to the values from 0 through 255 in ascending order; that is, $S[0] = 0, S[1] = 1, \dots, S[255] = 255$. A temporary vector, T , is also created. If the length of the key K is 256 bytes, then K is transferred to T . Otherwise, for a key of length $keylen$ bytes, the first $keylen$ elements of T are copied from K , and then K is repeated as many times as necessary to fill out T . These preliminary operations can be summarized as

```
/* Initialization */
for i = 0 to 255 do
  S[i] = i;
  T[i] = K[i mod keylen];
```

Next we use T to produce the initial permutation of S . This involves starting with $S[0]$ and going through to $S[255]$, and for each $S[i]$, swapping $S[i]$ with another byte in S according to a scheme dictated by $T[i]$:

```
/* Initial Permutation of S */
j = 0;
for i = 0 to 255 do
    j = (j + S[i] + T[i]) mod 256;
    Swap (S[i], S[j]);
```

Because the only operation on S is a swap, the only effect is a permutation. S still contains all the numbers from 0 through 255.

Stream Generation

Once the S vector is initialized, the input key is no longer used. Stream generation involves cycling through all the elements of $S[i]$, and for each $S[i]$, swapping $S[i]$ with another byte in S according to a scheme dictated by the current configuration of S . After $S[255]$ is reached, the process continues, starting over again at $S[0]$:

```
/* Stream Generation */
i, j = 0;
while (true)
    i = (i + 1) mod 256;
    j = (j + S[i]) mod 256;
    Swap (S[i], S[j]);
    t = (S[i] + S[j]) mod 256;
    k = S[t];
```

To encrypt, XOR the value k with the next byte of plaintext. To decrypt, XOR the value k with the next byte of ciphertext.

Figure 8.7 illustrates the RC4 logic.

Strength of RC4

More recently, [PAUL07] revealed a more fundamental vulnerability in the RC4 key scheduling algorithm that reduces the amount of effort to discover the key. Recent cryptanalysis results [ALFA13] exploit biases in the RC4 keystream to recover repeatedly encrypted plaintexts. As a result of the discovered weaknesses, particularly those reported in [ALFA13], the IETF issued RFC 7465 prohibiting the use of RC4 in TLS (*Prohibiting RC4 Cipher Suites*, February 2015). In its latest TLS guidelines, NIST also prohibited the use of RC4 for government use (SP 800-52, *Guidelines for the Selection, Configuration, and Use of Transport Layer Security (TLS) Implementations*, September 2013).

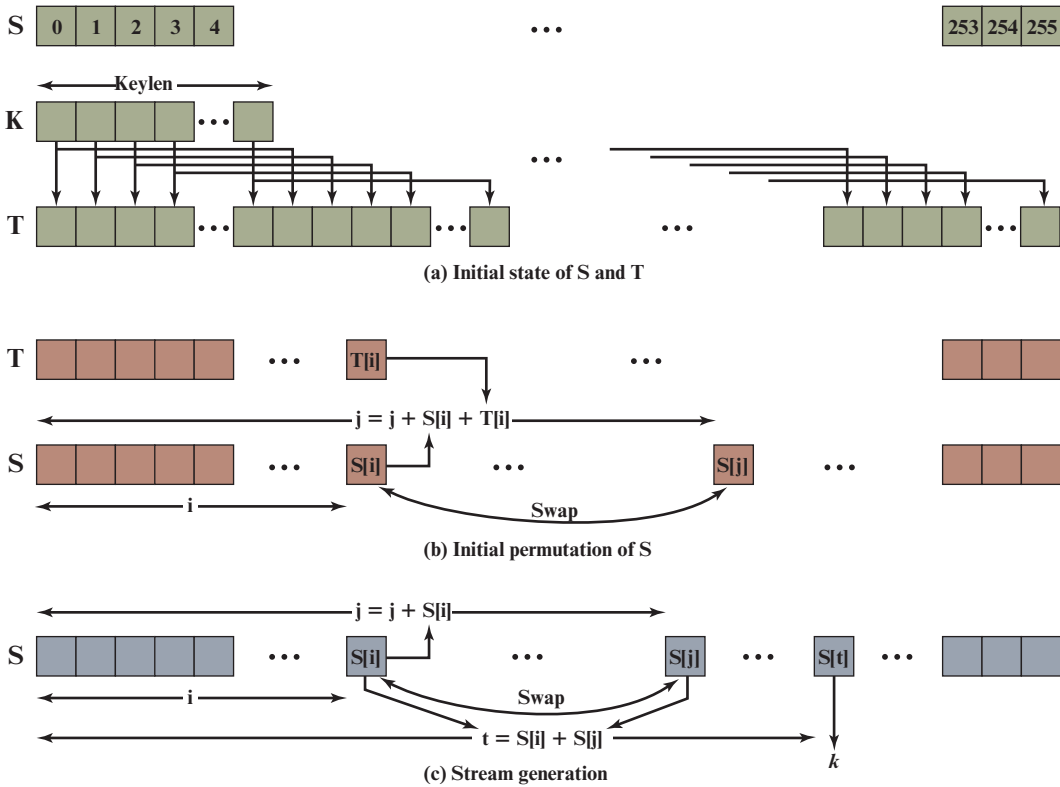

Figure 8.7 RC4

8.6 STREAM CIPHERS USING FEEDBACK SHIFT REGISTERS

With the increasing use of highly constrained devices, such as those used in the IoT, there has been increasing interest in developing new stream ciphers that take up minimal memory, are highly efficient, and have minimal power consumption requirements. Most of the recently developed stream ciphers are based on the use of feedback shift registers (FSRs). Feedback shift registers exhibit the desired performance behavior, are well-suited to compact hardware implementation, and there are well-developed theoretical results on the statistical properties of the bit sequences they produce.

An FSR consists of a sequence of 1-bit memory cells. Each cell has an output line, which indicates the value currently stored, and an input line. At discrete time instants, known as clock times, the value in each storage device is replaced by the value indicated by its input line. The effect is as follows: The rightmost (least significant) bit is shifted out as the output bit for this clock cycle. The other bits are shifted one bit position to the right. The new leftmost (most significant) bit is calculated as a function of the other bits in the FSR.

This section introduces the two types of feedback shift registers: linear feedback shift registers (LFSRs) and nonlinear feedback shift registers. We then examine a contemporary example: the Grain stream cipher.

Linear Feedback Shift Registers

In general, a function f is linear if $f(x + y) = f(x) + f(y)$, and $af(x) = f(ax)$. For the specific case of an FSR, an FSR is linear if the feedback function only involves modulo-2 (logical exclusive-OR) addition of bits in the register.

The circuit is implemented as follows:

1. The LFSR contains n bits.
2. There are from 1 to $(n - 1)$ XOR gates.
3. The presence or absence of a gate corresponds to the presence or absence of a term in the characteristic polynomial (explained subsequently), $P(X)$, excluding the X^n term.

Two equivalent ways of characterizing the LFSR are used. We can think of the generator as implementing a sum of XOR terms:

$$B_n = A_1B_{n-1} \oplus A_2B_{n-2} \oplus A_3B_{n-3} \oplus \dots \oplus A_nB_0 = \sum_{i=1}^n A_iB_{n-i} \tag{8.1}$$

Figure 8.8 illustrates this equation. At each clock signal, the B_i values are calculated and shifted right. Thus, the calculated value of B_n becomes the value in the B_{n-1} cell, and so on down to B_0 , which is shifted out as the output bit. An actual implementation would not have the multiply circuits; instead, for $A_i = 0$, the corresponding XOR circuit is eliminated. Figure 8.9a is an example of a 4-bit LFSR that implements the equation:

$$B_4 = B_0 \oplus B_1 \tag{8.2}$$

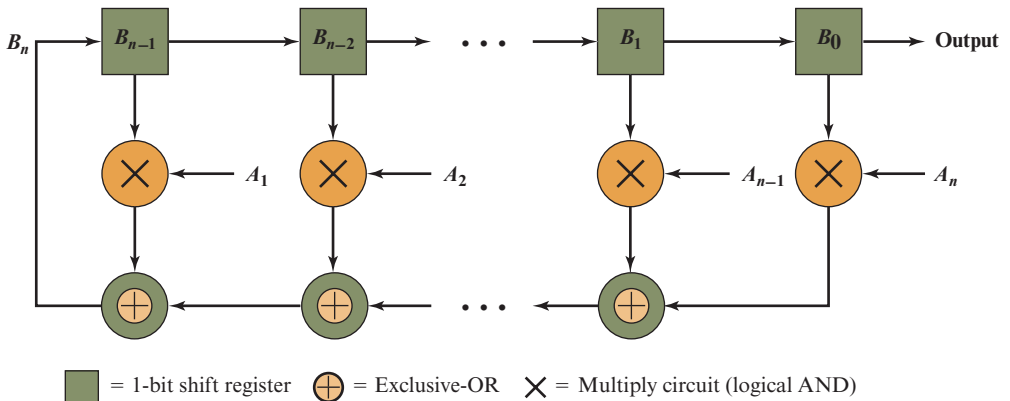
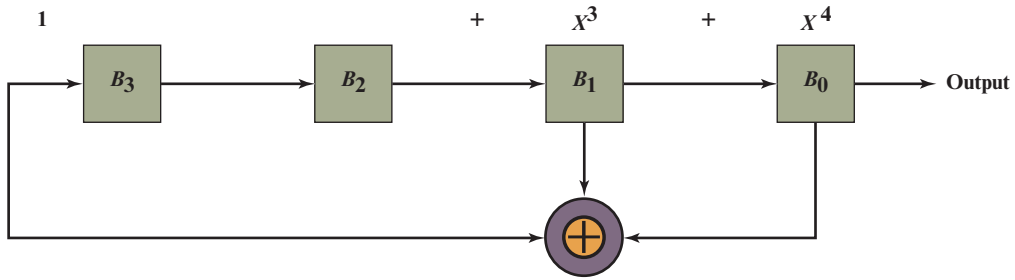

Figure 8.8 Binary Linear Feedback Shift Register Sequence Generator



(a) Shift-register implementation

State	B_3	B_2	B_1	B_0	$B_0 \oplus B_1$	output
Initial = 0	1	0	0	0	0	0
1	0	1	0	0	0	0
2	0	0	1	0	1	0
3	1	0	0	1	1	1
4	1	1	0	0	0	0
5	0	1	1	0	1	0
6	1	0	1	1	0	1
7	0	1	0	1	1	1
8	1	0	1	0	1	0
9	1	1	0	1	1	1
10	1	1	1	0	1	0
11	1	1	1	1	0	1
12	0	1	1	1	0	1
13	0	0	1	1	0	1
14	0	0	0	1	1	1
15 = 0	1	0	0	0	0	0

(b) Example with initial state of 1000

Figure 8.9 4-Bit Linear Feedback Shift Register

The shift register technique has several important advantages. The sequences generated by an LFSR can be nearly random with long periods. In addition, LFSRs are easy to implement in hardware and can run at high speeds.

It can be shown that the output of an n -bit LFSR is periodic with maximum period $N = 2^n - 1$. The all-zeros sequence occurs only if either the initial contents of the LFSR are all zero or the coefficients in Equation (8.1) are all zero (no feedback). A feedback configuration can always be found that gives a period of N ; the resulting sequences are called **maximal-length sequences**, or **m-sequences**.

Figure 8.9b shows the generation of an m-sequence for the LFSR of Figure 8.9a. The LFSR implements Equation (8.2) with an initial state of 1000 ($B_3 = 1, B_2 = 0, B_1 = 0, B_0 = 0$). Figure 8.9b shows the step-by-step operation as the LFSR is clocked one bit at a time. Each row of the table shows the values currently stored in the four shift register elements. In addition, the row shows the value that appears at the output of the exclusive-OR circuit. Finally, the row shows the value of the output bit, which is just B_0 . Note that the output repeats after 15 bits. That is, the period of the sequence, or the length of the m-sequence, is $15 = 2^4 - 1$. This same periodic m-sequence is generated regardless of the initial state of the LFSR (except for 0000), as shown in Figure 8.9. With each different initial state, the m-sequence begins at a different point in its cycle, but it is the same sequence.

For any given size of LFSR, a number of different unique m-sequences can be generated by using different values for the A_i in Equation (8.1).

An equivalent definition of an LFSR configuration is a **characteristic polynomial**. The characteristic polynomial $P(X)$ that corresponds to Equation (8.1) has the form:

$$P(X) = 1 + A_1X + A_2X^2 + \dots + A_{n-1}X^{n-1} + A_nX^n = 1 + \sum_{i=1}^n A_iX^i \quad (8.3)$$

One useful attribute of the characteristic polynomial is that it can be used to find the sequence generated by the corresponding LFSR, by taking the reciprocal of the polynomial. For example, for the 3-bit LFSR with $P(X) = 1 + X + X^3$,

$$\begin{array}{r}
 1 + X + X^3 \overline{) \begin{array}{l} 1 + X + X^2 + \quad X^4 + \quad X^7 + X^8 + \quad \dots \\ 1 \\ \hline 1 + X + \quad X^3 \\ \quad X \quad X^3 \\ \hline \quad X + X^2 + \quad X^4 \\ \quad \quad X^2 + X^3 + X^4 \\ \hline \quad \quad X^2 + X^3 + \quad X^5 \\ \quad \quad \quad X^4 + X^5 \\ \hline \quad \quad \quad X^4 + X^5 + \quad X^7 \\ \quad \quad \quad \quad X^7 \\ \hline \quad \quad \quad \quad X^7 + X^8 + \quad X^{10} \\ \quad \quad \quad \quad \quad X^8 + \quad X^{10} \\ \hline \quad \quad \quad \quad \quad X^8 + X^9 + \quad X^{11} \end{array} \\
 \end{array}$$

Figure 8.10 $1/(1 + X + X^3)$

we perform the division $1/(1 + X + X^3)$. Figure 8.10 depicts the long division. The result is:

$$1 + X + X^2 + (0 \times X^3) + X^4 + (0 \times X^5) + (0 \times X^6)$$

after which the pattern repeats. This means that the shift register output is 1110100.

Because the period of this sequence is $7 = 2^3 - 1$, this is an m-sequence. Notice that we are doing division somewhat differently from the normal method. This is because the subtractions are done modulo 2, or using the XOR function, and in this system, subtraction produces the same result as addition.

A characteristic polynomial produces an m-sequence if and only if it is a primitive polynomial.² Thus, $P(X) = 1 + X + X^3$ is a primitive polynomial. Similarly, the polynomial corresponding to Figure 8.9a is $P(X) = 1 + X + X^4$, which is a primitive polynomial.

Alternatively, some sources in the literature define a **generating polynomial** as follows:

$$G(X) = X^n P\left(\frac{1}{X}\right) = X^n + \sum_{i=1}^n A_i X^{n-i}$$

There is no practical difference; both $P(X)$ and $G(X)$ generate the same output bit sequence.

Although a LFSR defined by a primitive polynomial produces a good pseudorandom number bit stream, a single LFSR by itself is not suitable as a stream cipher. The stream cipher would simply consist of taking the XOR of successive bits of plaintext with successive bits generated by the LFSR. If an n -bit LFSR is used as a stream cipher, then the initial contents of the register constitute the key. It can be shown that if the feedback function is known (i.e., the values of the A_i are known) and if an adversary can determine n consecutive bits of the stream, then the adversary can determine the entire stream. This is due to the linearity of the feedback function. Further, if the feedback function is not known, then $2n$ bits of the output stream suffice to determine the entire stream.

One way to develop an LFSR-based stream cipher is to use multiple LFSRs, perhaps of different lengths, that are combined in some fashion. Another way is to incorporate a nonlinear feedback shift register (NFSR).

Nonlinear Feedback Shift Registers

The term *linear*, in the context of LFSR, means that the coefficients A_i in Equations 8.1 and 8.3 are constants; in particular these are Boolean constants (0 or 1). For an NFSR, the coefficients may be variables. An example is Figure 8.11, which can be expressed as:

$$B_5 = B_4 \oplus B_3 B_2$$

²Primitive polynomials are defined in Chapter 5.

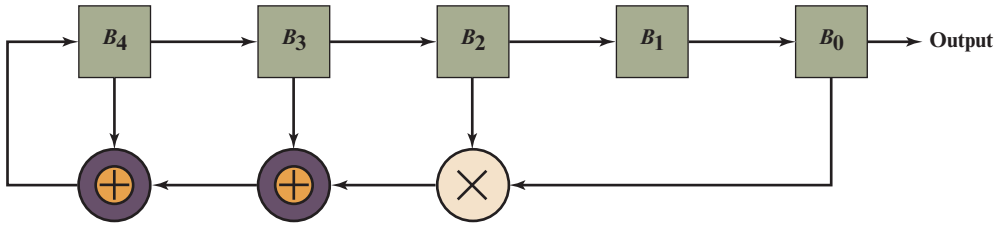

Figure 8.11 A Nonlinear Feedback Shift Register

or, equivalently:

$$P(X) = 1 + X + X^2X^4$$

As with LFSRs, an NFSR is not by itself suitable as a stream cipher. There is no theory to analyze them. However, it may be combined with an LFSR to produce a stream cipher of known maximum period and high security.

Grain-128a

Grain is a family of hardware-efficient stream ciphers. Grain was accepted as part of the eSTREAM effort to approve a number of new stream ciphers (described in Chapter 23). The eSTREAM specification, called Grain v1, defines two stream ciphers, one with an 80-bit key and a 64-bit initialization vector (IV), and one with a 128-bit key and 80-bit IV. Grain has since been revised and expanded to include authentication, referred to as Grain-128a [AGRE11, HELL06]. The eSTREAM final report [BABB08] states that Grain has pushed the state of the art in terms of compact implementation.

Grain-128a consists of two shift registers, one with linear feedback and the second with nonlinear feedback, and a filter function. The registers are coupled by very lightweight, but judiciously chosen Boolean functions. The LFSR guarantees a minimum period for the keystream, and it also provides balancedness in the output. The NFSR, together with a nonlinear filter, introduces nonlinearity to the cipher. The input to the NFSR is masked with the output of the LFSR so that the state of the NFSR is balanced.

OUTPUT FOR ENCRYPTION Figure 8.12a shows the structure of Grain-128a for producing a stream of output bits to be used for encrypting a stream of plaintext by a simple bitwise XOR operation. Grain-128a uses a convention of numbering the bits in the registers increasing from left to right and doing a left shift, with the leftmost bit as output. The LFSR at iteration i is defined as follows:

$$s_{i+128} = s_i \oplus s_{i+7} \oplus s_{i+38} \oplus s_{i+70} \oplus s_{i+81} \oplus s_{i+96}$$

The equivalent generator function is:

$$f(x) = 1 + x^{32} + x^{47} + x^{58} + x^{90} + x^{121} + x^{128}$$

The NFSR is defines as follows:

$$\begin{aligned}
 b_{i+128} = & s_i \oplus b_i \oplus b_{i+26} \oplus b_{i+56} \oplus b_{i+91} \oplus b_{i+96} \\
 & \oplus b_{i+3}b_{i+67} \oplus b_{i+11}b_{i+13} \oplus b_{i+17}b_{i+18} \\
 & \oplus b_{i+27}b_{i+59} \oplus b_{i+40}b_{i+48} \oplus b_{i+61}b_{i+65} \\
 & \oplus b_{i+68}b_{i+84} \oplus b_{i+88}b_{i+92}b_{i+93}b_{i+95} \\
 & \oplus b_{i+22}b_{i+24}b_{i+25} \oplus b_{i+70}b_{i+78}b_{i+82}
 \end{aligned}$$

The equivalent generator function, which is a primitive polynomial, is:

$$\begin{aligned}
 g1(x) &= 1 + x^{32} + x^{37} + x^{72} + x^{102} + x^{128} \\
 g2(x) &= x^{44}x^{60} + x^{61}x^{125} + x^{63}x^{67} + x^{69}x^{101} + x^{80}x^{88} + x^{110}x^{111} \\
 &\quad + x^{115}x^{117} + x^{46}x^{50}x^{58} + x^{103}x^{104}x^{106} + x^{33}x^{35}x^{36}x^{40} \\
 g(x) &= g1(x) + g2(x)
 \end{aligned}$$

Thus, the NFSR output has both linear and nonlinear components. Note that the generator function for the NFSR does not feed directly back into the register but is XORed with the LFSR output s_i , which masks the input to the NFSR.

The actual generation of an output bit from the grain structure proceeds in several stages. The filter function h takes 9 variables from the two shift registers. It is designed to be balanced, highly nonlinear, and produce secure output. It is defined as:

$$h = b_{i+12}s_{i+8} \oplus s_{i+13}s_{i+20} \oplus s_{i+95}s_{i+42} \oplus s_{i+60}s_{i+79}s_{i+94}$$

Next, a pre-output function masks h with 1 bit of the LFSR and 7 bits of the NFSR, using the following simple linear function:

$$y_i = h \oplus s_{i+93} \oplus \sum_{j \in A} b_{i+j}$$

where $A = \{2, 15, 36, 45, 64, 73, 89\}$. The output function is defined as

$$z_i = y_{64+2i}$$

That is, the output consists of every second bit after skipping the first 64 bits. These 64 initial bits and the other half may be used for authentication, as described subsequently.

Because the LFSR is 128 bits and uses a primitive polynomial, the period is guaranteed to be at least $2^{128} - 1$. Because of the NFSR and the fact that the input to this is masked with the output of the LFSR, the exact period will depend on the key and the IV used. The input to the NFSR is masked with the output of the LFSR in order to make sure that the NFSR state is balanced.

KEY AND IV INITIALIZATION Grain-128a is initialized by placing the 128-bit key in the 128-bit NFSR. The 128-bit LFSR is initialized using the 96 bits IV_i of the IV as follows:

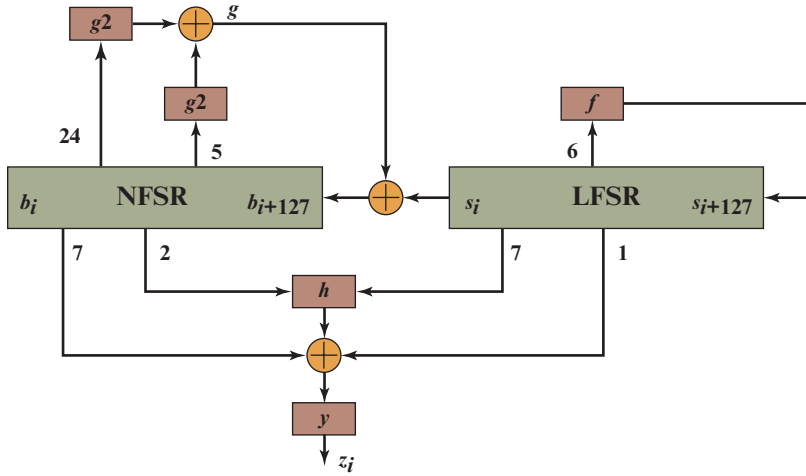

(a) Output generator

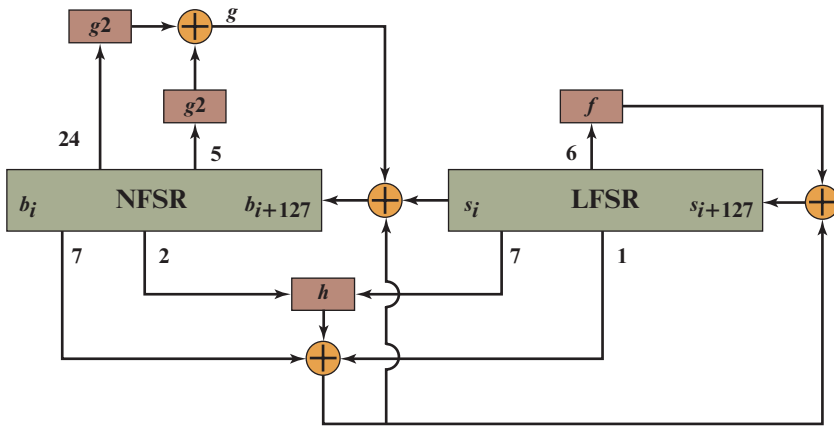

(b) Key initialization

Figure 8.12 Grain-128a Stream Cipher

$$s_i = \begin{cases} IV_i & 0 \leq i \leq 95 \\ 1 & 96 \leq i \leq 126 \\ 0 & i = 127 \end{cases}$$

Then, the two registers, comprising 256 bits, are clocked 256 times without producing any keystream. Instead, the pre-output function is fed back and XORed with the input to both the NFSR and LFSR (Figure 8.12b). This operation fully replaces the IV and key with the initial state of the registers. This process effectively scrambles the contents of the shift registers before the keystream is generated.

ENCRYPTION Encryption is now easily defined. Assume a message of length L defined by the bits m_0, \dots, m_{L-1} . Then the ciphertext bits c_i are calculated as:

$$c_i = z_i \oplus m_i$$

And the message is recovered from the ciphertext as follows:

$$m_i = z_i \oplus c_i$$

AUTHENTICATION Optionally, Grain-128a generates a 32-bit authentication tag. For this purpose, there is a 32-bit register called the accumulator, with the bits at time i denoted by a_i^0, \dots, a_i^{31} . There is also a 32-bit shift register, with the bits at time i denoted by r_i, \dots, r_{i+31} . The accumulator is initialized with the first 32 bits of y_i and the register is initialized with the second sequence of 32 bits of y_i . Recall that these 64 bits were excluded in forming z_i . At each time i , the shift register is updated by assigning $r_{i+32} = y_{64+2i+1}$, and then shifting left 1 bit. Thus, the bits not used in encryption are used for authentication. At each time i , all of the bits of the accumulator are updated as $a_{i+1}^j = a_i^j \oplus m_{i+j}$ for $0 \leq j \leq 31$ and $0 \leq i \leq L$. The final content of the accumulator, $a_{L+1}^0, \dots, a_{L+1}^{31}$, is the authentication tag.

8.7 TRUE RANDOM NUMBER GENERATORS

Entropy Sources

A true random number generator (TRNG) uses a nondeterministic source to produce randomness. Most operate by measuring unpredictable natural processes, such as pulse detectors of ionizing radiation events, gas discharge tubes, and leaky capacitors. Intel has developed a commercially available chip that samples thermal noise by sampling the output of a coupled pair of inverters. LavaRnd is an open source project for creating truly random numbers using inexpensive cameras, open source code, and inexpensive hardware. The system uses a saturated CCD in a light-tight can as a chaotic source to produce the seed. Software processes the result into truly random numbers in a variety of formats.

RFC 4086 lists the following possible sources of randomness that, with care, easily can be used on a computer to generate true random sequences.

- **Sound/video input:** Many computers are built with inputs that digitize some real-world analog source, such as sound from a microphone or video input from a camera. The “input” from a sound digitizer with no source plugged in or from a camera with the lens cap on is essentially thermal noise. If the system has enough gain to detect anything, such input can provide reasonably high quality random bits.
- **Disk drives:** Disk drives have small random fluctuations in their rotational speed due to chaotic air turbulence [JAKO98]. The addition of low-level disk seek-time instrumentation produces a series of measurements that contain this randomness. Such data is usually highly correlated, so significant processing is needed. Nevertheless, experimentation a decade ago showed that, with such

Table 8.5 Comparison of PRNGs and TRNGs

	Pseudorandom Number Generators	True Random Number Generators
Efficiency	Very efficient	Generally inefficient
Determinism	Deterministic	Nondeterministic
Periodicity	Periodic	Aperiodic

processing, even slow disk drives on the slower computers of that day could easily produce 100 bits a minute or more of excellent random data.

There is also an online service (random.org), which can deliver random sequences securely over the Internet.

Comparison of PRNGs and TRNGs

Table 8.5 summarizes the principal differences between PRNGs and TRNGs. PRNGs are efficient, meaning they can produce many numbers in a short time, and deterministic, meaning that a given sequence of numbers can be reproduced at a later date if the starting point in the sequence is known. Efficiency is a nice characteristic if your application needs many numbers, and determinism is handy if you need to replay the same sequence of numbers again at a later stage. PRNGs are typically also periodic, which means that the sequence will eventually repeat itself. While periodicity is hardly ever a desirable characteristic, modern PRNGs have a period that is so long that it can be ignored for most practical purposes.

TRNGs are generally rather inefficient compared to PRNGs, taking considerably longer time to produce numbers. This presents a difficulty in many applications. For example, cryptography system in banking or national security might need to generate millions of random bits per second. TRNGs are also nondeterministic, meaning that a given sequence of numbers cannot be reproduced, although the same sequence may of course occur several times by chance. TRNGs have no period.

Conditioning³

A TRNG may produce an output that is biased in some way, such as having more ones than zeros or vice versa. More generally, NIST SP 800-90B defines a random process as **biased** with respect to an assumed discrete set of potential outcomes (i.e., possible output values) if some of those outcomes have a greater probability of occurring than do others. For example, a physical source such as electronic noise may contain a superposition of regular structures, such as waves or other periodic phenomena, which may appear to be random, yet are determined to be non-random using statistical tests.

In addition to bias, another concept used by SP 800-98B is that of **entropy rate**. SP 800-90B defines entropy rate as the rate at which a digitized noise source (or entropy source) provides entropy; it is computed as the assessed amount of entropy provided by a bit string output from the source, divided by the total number of bits in the bit string

³ The reader unfamiliar with the concepts of entropy and min-entropy should read Appendix B before proceeding.

(yielding assessed bits of entropy per output bit). This will be a value between 0 (no entropy) and 1 (full entropy). Entropy rate is a measure of the randomness or unpredictability of a bit string. Another way of expressing it is that the entropy rate is k/n for a random source of length n bits and min-entropy k . Min-entropy is a measure of the number of random bits and is explained in Appendix B. In essence, a block of bits or a bit stream that is unbiased, and in which each bit and each group of bits is independent of all other bits and groups of bits will have an entropy rate of 1.

For hardware sources of random bits, the recommended approach is to assume that there may be bias and/or an entropy rate of less than 1 and to apply techniques to further “randomize” the bits. Various methods of modifying a bit stream for this purpose have been developed. These are referred to as **conditioning algorithms** or **deskewing algorithms**.

Typically, conditioning is done by using a cryptographic algorithm to “scramble” the random bits so as to eliminate bias and increase entropy. The two most common approaches are the use of a hash function or a symmetric block cipher.

HASH FUNCTION As we describe in Chapter 11, a hash function produces an n -bit output from an input of arbitrary length. A simple way to use a hash function for conditioning is as follows. Blocks of m input bits, with $m \geq n$, are passed through the hash function and the n output bits are used as random bits. To generate a stream of random bits, successive input blocks pass through the hash function to produce successive hashed output blocks.

Operating systems typically provide a built-in mechanism for generating random numbers. For example, Linux uses four entropy sources: mouse and keyboard activity, disk I/O operations, and specific interrupts. Bits are generated from these four sources and combined in a pooled buffer. When random bits are needed, the appropriate number of bits are read from the buffer and passed through the SHA-1 hash function [GUTT06].

A more complex approach is the hash derivation function specified in SP800-90A. Hash_df can be defined as follows:

Parameters:

input_string: The string to be hashed.

outlen: Output length.

no_of_bits_to_return: The number of bits to be returned by Hash_df. The maximum length (*max_number_of_bits*) is implementation dependent, but shall be less than or equal to $(255 \times outlen)$. *no_of_bits_to_return* is represented as a 32-bit integer.

requested_bits: The result of performing the Hash_df.

Hash_df Process:

1. *temp* = the Null string
2. $len = \left\lceil \frac{no_of_bits_to_return}{outlen} \right\rceil$

3. *counter* = 0x01 Comment: An 8-bit binary value representing the integer “1”
4. For $i = 1$ to *len* do Comment: In 4.1, *no_of_bits_to_return* is used as a 32-bit string.
 - 4.1. *temp* = *temp* || **Hash** (*counter* || *no_of_bits_to_return* || *input_string*).
 - 4.2. *counter* = *counter* + 1.
5. *requested_bits* = **leftmost** (*temp*, *no_of_bits_to_return*).
6. Return (**SUCCESS**, *requested_bits*).

This algorithm takes an input block of bits of arbitrary length and returns the requested number of bits, which may be up to 255 times as long as the hash output length.

The reader may be uneasy that the output consists of hashed blocks in which the input to the hash function for each block is the same input string and differs only by the value of the counter. However, cryptographically strong hash functions, such as the SHA family, provide excellent diffusion (as defined in Chapter 4) so that change in the counter value results in dramatically different outputs.

BLOCK CIPHER Instead of a hash function, a block cipher such as AES can be used to scramble the TRNG bits. Using AES, a simple approach would be to take 128-bit blocks of TRNG bits and encrypt each block with AES and some arbitrary key. SP 800-90B outlines an approach similar to the `hash_df` function described previously. The Intel implementation discussed subsequently provides an example of using AES for conditioning.

Health Testing

Figure 8.13 provides a general model for a nondeterministic random bit generator. A hardware noise source produces a true random output. This is digitized to produce true, or nondeterministic, source of bits. This bit source then passes through a conditioning module to mitigate bias and maximize entropy.

Figure 8.13 also shows a health-testing module, which is used on the outputs of both the digitizer and conditioner. In essence, health testing is used to validate that the noise source is working as expected and that the conditioning module is produced output with the desired characteristics. Both forms of health testing are recommended by SP 800-90B.

HEALTH TESTS ON THE NOISE SOURCE The nature of the health testing of the noise source depends strongly on the technology used to produce noise. In general, we can assume that the digitized output of the noise source will exhibit some bias. Thus, the traditional statistical tests, such as those defined in SP 800-22 and discussed in Section 8.1, are not useful for monitoring the noise source, because the noise source is likely to always fail. Rather, the tests on the noise source need to be tailored to the expected statistical behavior of the correctly operating noise source. The goal is not to determine if the source is unbiased, which it isn't, but if it is operating as expected.

SP 800-90B specifies that continuous tests be done on digitized samples obtained from the noise source (point A in Figure 8.13). The purpose is to test for variability. More specifically, the purpose is to determine if the noise source is

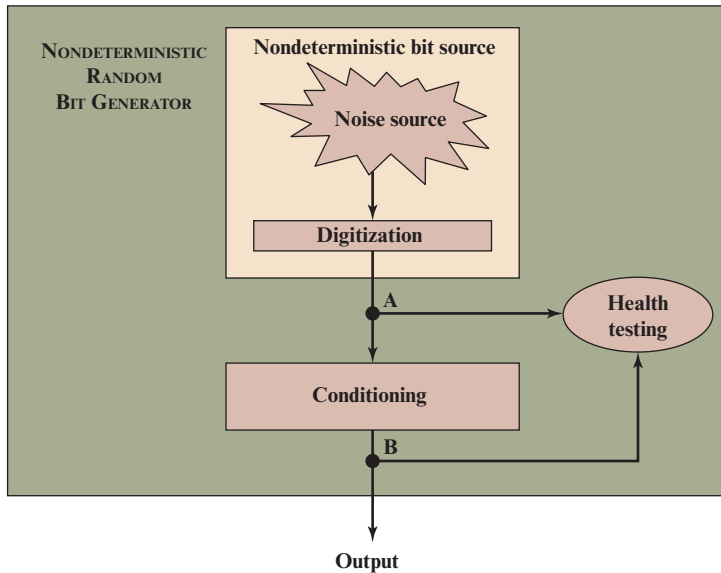

Figure 8.13 NRBG Model

producing at the expected entropy rate. SP 800-90B mandates the use of two tests: the Repetition Count Test and the Adaptive Proportion Test.

The **Repetition Count Test** is designed to quickly detect a catastrophic failure that causes the noise source to become “stuck” on a single output value for a long time. For this test, it is assumed that a given noise source is assessed to have a given min-entropy value of H . The entropy is expressed as the amount of entropy per sample, where a sample could be a single bit or some block of bits of length n . With an assessed value of H , it is straightforward to calculate the probability that a sequence of C consecutive samples will yield identical sample values. For example, a noise source with one bit of min-entropy per sample has no more than a $1/2$ probability of repeating some sample value twice in a row, no more than $1/4$ probability of repeating some sample value three times in a row, and in general, no more than $(1/2)^{C-1}$ probability of repeating some sample value C times in a row. To generalize, for a noise source with H bits of min-entropy per sample, we have:

$$\Pr[C \text{ identical samples in a row}] \leq (2^{-H})^{(C-1)}$$

The Repetition Count Test involves looking for consecutive identical samples. If the count reaches some cutoff value C , then an error condition is raised. To determine the value of C used in the test, the test must be configured with a parameter W , which is the acceptable false-positive probability associated with an alarm triggered by C repeated sample values. To avoid false positives, W should be set at some very small number greater than 0. Given W , we can now determine the value of C . Specifically, we want C to be the smallest number that satisfies the equation $W \leq (2^{-H})^{(C-1)}$. Reworking terms, this gives us a value of:

$$C = \left\lceil 1 + \frac{-\log(W)}{H} \right\rceil$$

For example, for $W = 2^{-30}$, an entropy source with $H = 7.3$ bits per sample would have a cutoff value C of $\left\lceil 1 + \frac{30}{7.3} \right\rceil = 6$.

The Repetition Count Test starts by recording a sample value and then counting the number of repetitions of the same value. If the counter reaches the cutoff value C , an error is reported. If a sample value is encountered that differs from the preceding sample, then the counter is reset to 1 and the algorithm starts over.

The **Adaptive Proportion Test** is designed to detect a large loss of entropy, such as might occur as a result of some physical failure or environmental change affecting the noise source. The test continuously measures the local frequency of occurrence of some sample value in a sequence of noise source samples to determine if the sample occurs too frequently.

The test starts by recording a sample value and then observes N successive sample values. If the initial sample value is observed at least C times, then an error condition is reported. SP 800-90B recommends that a probability of a false positive of $W = 2^{-30}$ be used for the test and provides guidance on the selection of values for N and C .

HEALTH TESTS ON THE CONDITIONING FUNCTION SP 800-90B specifies that health tests should also be applied to the output of the conditioning component (point B in Figure 8.13), but does not indicate which tests to use. The purpose of the health tests on the conditioning component is to assure that the output behaves as a true random bit stream. Thus, it is reasonable to use the tests for randomness defined in SP 800-22, and described in Section 8.1.

Intel Digital Random Number Generator

As was mentioned, TRNGs have traditionally been used only for key generation and other applications where only a small number of random bits were required. This is because TRNGs have generally been inefficient, with a low bit rate of random bit production.

The first commercially available TRNG that achieves bit production rates comparable with that of PRNGs is the Intel digital random number generator (DRNG) [TAYL11, MECH14], offered on new multicore chips since May 2012.⁴

Two notable aspects of the DRNG:

1. It is implemented entirely in hardware. This provides greater security than a facility that includes a software component. A hardware-only implementation should also be able to achieve greater computation speed than a software module.

⁴It is unfortunate that Intel chose the acronym DRNG for an NRBG. It confuses with DRBG, which is a pseudorandom number bit generator.

2. The entire DRNG is on the same multicore chip as the processors. This eliminates the I/O delays found in other hardware random number generators.

DRNG HARDWARE ARCHITECTURE Figure 8.14 shows the overall structure of the DRNG. The first stage of the DRNG generates random numbers from thermal noise. The heart of the stage consists of two inverters (NOT gates), with the output of each inverter connected to the input of the other. Such an arrangement has two stable states, with one inverter having an output of logical 1 and the other having an output of logical 0. The circuit is then configured so that both inverters are forced to have the same indeterminate state (both inputs and both outputs at logical 1) by clock pulses. Random thermal noise within the inverters soon jostles the two inverters into a mutually stable state. Additional circuitry is intended to compensate for any biases or correlations. This stage is capable, with current hardware, of generating random bits at a rate of 4 Gbps.

The output of the first stage is generated 512 bits at a time. To assure that the bit stream does not have **skew** or bias, a conditioner randomizes its input using a cryptographic function. In this case, the function is referred to as CBC-MAC or

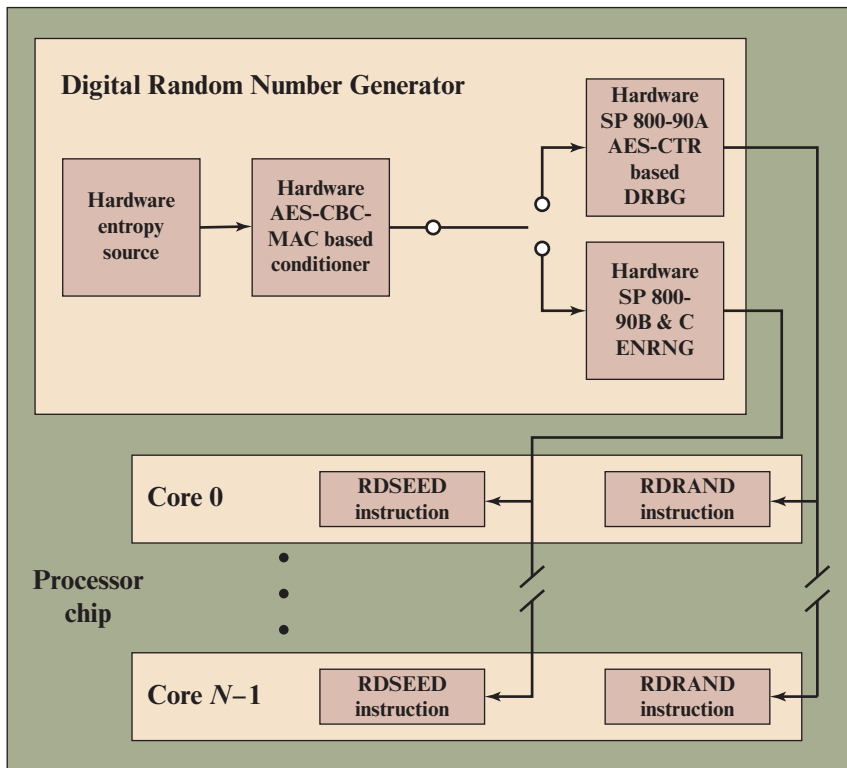

Figure 8.14 Intel Processor Chip with Random Number Generator

CMAC, as specified in NIST SP 800-38B. In essence, CMAC encrypts its input using the cipher block chaining (CBC) mode (Figure 8.4) and outputs the final block. We examine CMAC in detail in Chapter 12. The output of this stage is generated 256 bits at a time and is intended to exhibit true randomness with no skew or bias.

While the hardware's circuitry generates random numbers from thermal noise much more quickly than its predecessors, it is still not fast enough for some of today's computing requirements. To enable the DRNG to generate random numbers as quickly as a software DRBG, and also maintain the high quality of the random numbers, a third stage is added. This stage uses the 256-bit random numbers to seed a cryptographically secure DRBG that creates 128-bit numbers. From one 256-bit seed, the DRBG can output many pseudorandom numbers, exceeding the 3-Gbps rate of the entropy source. An upper bound of 511 128-bit samples can be generated per seed. The algorithm used for this stage is CTR_DRBG, described in Section 8.3.

The output of the PRNG stage is available to each of the cores on the chip via the RDRAND instruction. RDRAND retrieves a 16-, 32-, or 64-bit random value and makes it available in a software-accessible register.

Preliminary data from a pre-production sample on a system with a third generation Intel[®] Core[™] family processor produced the following performance [INTE12]: up to 70 million RDRAND invocations per second, and a random data production rate of over 4 Gbps.

The output of the conditioner is also made available to another module, known as an enhanced nondeterministic random number generator (ENRNG) that provides random numbers that can be used as seeds for various cryptographic algorithms. The ENRNG is compliant with specifications in SP 800-90B and 900-90C. The output of the ENRNG stage is available to each of the cores on the chip via the RDSEED instruction. RDSEED retrieves a hardware-generated random seed value from the ENRNG and stores it in the destination register given as an argument to the instruction.

DRNG LOGICAL STRUCTURE Figure 8.15 provides a simplified view of the logical flow of the Intel DRBG. As was described, the heart of the hardware entropy source is a pair of inverters that feed each other. Two transistors, driven by the same clock, force the inputs and outputs of both inverters to the logical 1 state. Because this is an unstable state, thermal noise will cause the configuration to settle randomly into a stable state with either Node A at logical 1 and Node B at logical 0, or the reverse. Thus the module generates random bits at the clock rate.

The output of the entropy source is collected 512 bits at a time and used to feed to two CBC hardware implementations using AES encryption. Each implementation takes two blocks of 128 bits of "plaintext" and encrypts using the CBC mode. The output of the second encryption is retained. For both CBC modules, an all-zeros key is used initially. Subsequently, the output of the PRNG stage is fed back to become the key for the conditioner stage.

The output of the conditioner stage consists of 256 bits. This block is provided as input to the update function of the DRBG stage. The update function is initialized

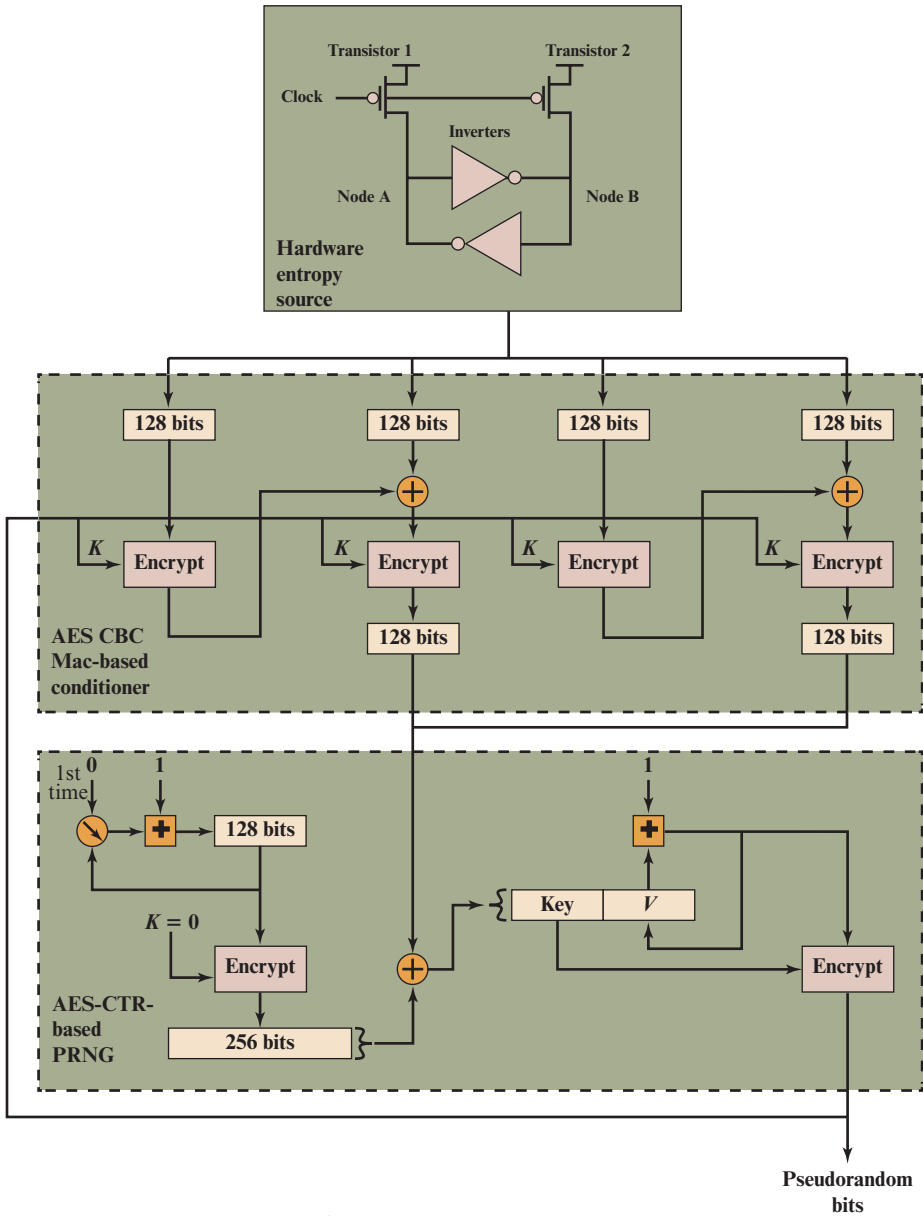

Figure 8.15 Intel DRNG Logical Structure

with the all-zeros key and the counter value 0. The function is iterated twice to produce a 256-block, which is then XORed with the input from the conditioner stage. The results are used as the 128-bit key and the 128-bit seed for the generate function. The generate function produces pseudorandom bits in 128-bit blocks.

8.8 KEY TERMS, REVIEW QUESTIONS, AND PROBLEMS

Key Terms

backward unpredictability deskewing algorithm entropy source forward unpredictability keystream	pseudorandom function (PRF) pseudorandom number generator (PRNG) seed skew	stream cipher true random number generator (TRNG) unpredictability
---	--	---

Review Questions

- 8.1 List two criteria to validate the randomness of a sequence of numbers.
- 8.2 What is ANSI X9.17 PRNG?
- 8.3 What is the recommended key length for a stream cipher to guard against brute force attacks?
- 8.4 What is the difference between a one-time pad and a stream cipher?
- 8.5 The 802.11 standard protocol used RC4 for its agility and simplicity for encryption and decryption. There are a few simple steps in RC4 including the initialization of S to a number from 0 to 255, followed by permutation. Explain the stream generation, and main benefits and drawbacks of RC4.
- 8.6 List a few applications of stream ciphers and block ciphers.

Problems

- 8.1 If we take the linear congruential algorithm with an additive component of 0,

$$X_{n+1} = (aX_n) \bmod m$$

Then it can be shown that if m is prime and if a given value of a produces the maximum period of $m - 1$, then a^k will also produce the maximum period, provided that k is less than m and that k and $m - 1$ are relatively prime. Demonstrate this by using $X_0 = 1$ and $m = 31$ and producing the sequences for $a^k = 3, 3^2, 3^3$, and 3^4 .

- 8.2 a. What is the maximum period obtainable from the following generator?

$$X_{n+1} = (aX_n) \bmod 2^4$$

- b. What should be the value of a ?
- c. What restrictions are required on the seed?
- 8.3 You may wonder why the modulus $m = 2^{31} - 1$ was chosen for the linear congruential method instead of simply 2^{31} , because this latter number can be represented with no additional bits and the mod operation should be easier to perform. In general, the modulus $2^k - 1$ is preferable to 2^k . Why is this so?
- 8.4 With the linear congruential algorithm, a choice of parameters that provides a full period does not necessarily provide a good randomization. For example, consider the following two generators:

$$X_{n+1} = (11X_n) \bmod 13$$

$$X_{n+1} = (2X_n) \bmod 13$$

Write out the two sequences to show that both are full periods. Which one appears more random to you?

- 8.5** In any use of pseudorandom numbers, whether for encryption, simulation, or statistical design, it is dangerous to trust blindly the random number generator that happens to be available in your computer's system library. [PARK88] found that many contemporary textbooks and programming packages make use of flawed algorithms for pseudorandom number generation. This exercise will enable you to test your system.

The test is based on a theorem attributed to Ernesto Cesaro (see [KNUT98] for a proof), which states the following: Given two randomly chosen integers, x and y , the probability that $\gcd(x, y) = 1$ is $6/\pi^2$. Use this theorem in a program to determine statistically the value of π . The main program should call three subprograms: the random number generator from the system library to generate the random integers; a subprogram to calculate the greatest common divisor of two integers using Euclid's Algorithm; and a subprogram that calculates square roots. If these latter two programs are not available, you will have to write them as well. The main program should loop through a large number of random numbers to give an estimate of the aforementioned probability. From this, it is a simple matter to solve for your estimate of π .

If the result is close to 3.14, congratulations! If not, then the result is probably low, usually a value of around 2.7. Why would such an inferior result be obtained?

- 8.6** What RC4 key value will leave S unchanged during initialization? That is, after the initial permutation of S , the entries of S will be equal to the values from 0 through 255 in ascending order.
- 8.7** RC4 has a secret internal state which is a permutation of all the possible values of the vector S and the two indices i and j .
- Using a straightforward scheme to store the internal state, how many bits are used?
 - Suppose we think of it from the point of view of how much information is represented by the state. In that case, we need to determine how many different states there are, then take the log to base 2 to find out how many bits of information this represents. Using this approach, how many bits would be needed to represent the state?
- 8.8** Alice and Bob agree to communicate privately via email using a scheme based on RC4, but they want to avoid using a new secret key for each transmission. Alice and Bob privately agree on a 128-bit key k . To encrypt a message m , consisting of a string of bits, the following procedure is used.
- Choose a random 64-bit value v
 - Generate the ciphertext $c = \text{RC4}(v \| k) \oplus m$
 - Send the bit string $(v \| c)$
 - Suppose Alice uses this procedure to send a message m to Bob. Describe how Bob can recover the message m from $(v \| c)$ using k .
 - If an adversary observes several values $(v_1 \| c_1), (v_2 \| c_2), \dots$ transmitted between Alice and Bob, how can he/she determine when the same key stream has been used to encrypt two messages?
 - Approximately how many messages can Alice expect to send before the same key stream will be used twice? Use the result from the birthday paradox described in Appendix E.
 - What does this imply about the lifetime of the key k (i.e., the number of messages that can be encrypted using k)?
- 8.9** Show that the polynomial $P(X) = 1 + X + X^4$ is a primitive generator polynomial for the circuit of Figure 8.9a by calculating $1/P(X)$ and showing that the coefficients of the resulting polynomial repeat the output pattern in Figure 8.9b.
- 8.10** This problem demonstrates that different LFSRs can be used to generate an m -sequence.
- Assume an initial state of 10000 in the LFSR of Figure 8.16a. In a manner similar to Figure 8.9b, show the generation of an m -sequence.
 - Now assume the configuration of Figure 8.16b, with the same initial state, and repeat part (a). Show that this configuration also produces an m -sequence, but that it is a different sequence from that produced by the first LFSR.

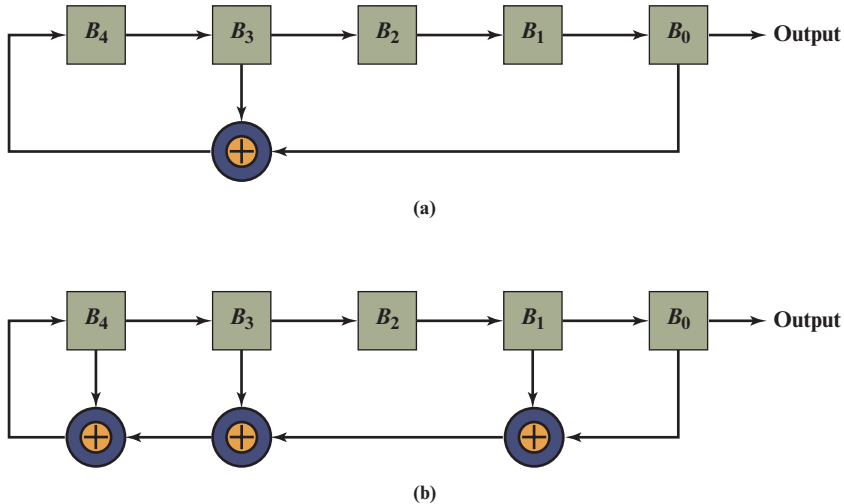

Figure 8.16 Two Different Configurations of LFSRs of Length 5

- 8.11** Suppose you have a true random bit generator where each bit in the generated stream has the same probability of being a 0 or 1 as any other bit in the stream and that the bits are not correlated; that is the bits are generated from identical independent distribution. However, the bit stream is biased. The probability of a 1 is $0.5 + \partial$ and the probability of a 0 is $0.5 - \partial$, where $0 < \partial < 0.5$. A simple conditioning algorithm is as follows: Examine the bit stream as a sequence of nonoverlapping pairs. Discard all 00 and 11 pairs. Replace each 01 pair with 0 and each 10 pair with 1.
- What is the probability of occurrence of each pair in the original sequence?
 - What is the probability of occurrence of 0 and 1 in the modified sequence?
 - What is the expected number of input bits to produce x output bits?
 - Suppose that the algorithm uses overlapping successive bit pairs instead of nonoverlapping successive bit pairs. That is, the first output bit is based on input bits 1 and 2, the second output bit is based on input bits 2 and 3, and so on. What can you say about the output bit stream?
- 8.12** Another approach to conditioning is to consider the bit stream as a sequence of nonoverlapping groups of n bits each and output the parity of each group. That is, if a group contains an odd number of ones, the output is 1; otherwise the output is 0.
- Express this operation in terms of a basic Boolean function.
 - Assume, as in the preceding problem, that the probability of a 1 is $0.5 + \partial$. If each group consists of 2 bits, what is the probability of an output of 1?
 - If each group consists of 4 bits, what is the probability of an output of 1?
 - Generalize the result to find the probability of an output of 1 for input groups of n bits.
- 8.13** It is important to note that the Repetition Count Test described in Section 8.6 is not a very powerful health test. It is able to detect only catastrophic failures of an entropy source. For example, a noise source evaluated at 8 bits of min-entropy per sample has a cutoff value of 5 repetitions to ensure a false-positive rate of approximately once per four billion samples generated. If that noise source somehow failed to the point that it was providing only 6 bits of min-entropy per sample, how many samples would be expected to be needed before the Repetition Count Test would notice the problem?

This page is intentionally left blank

PUBLIC-KEY CRYPTOGRAPHY AND RSA

9.1 Principles of Public-Key Cryptosystems

- Public-Key Cryptosystems
- Applications for Public-Key Cryptosystems
- Requirements for Public-Key Cryptography
- Public-Key Cryptanalysis

9.2 The RSA Algorithm

- Description of the Algorithm
- Computational Aspects
- The Security of RSA

9.3 Key Terms, Review Questions, and Problems

LEARNING OBJECTIVES

After studying this chapter, you should be able to:

- ◆ Present an overview of the basic principles of public-key cryptosystems.
- ◆ Explain the two distinct uses of public-key cryptosystems.
- ◆ List and explain the requirements for a public-key cryptosystem.
- ◆ Present an overview of the RSA algorithm.
- ◆ Understand the timing attack.
- ◆ Summarize the relevant issues related to the complexity of algorithms.

The development of public-key, or asymmetric, cryptography is the greatest and perhaps the only true revolution in the entire history of cryptography. From its earliest beginnings to modern times, virtually all cryptographic systems have been based on the elementary tools of substitution and permutation. After millennia of working with algorithms that could be calculated by hand, a major advance in symmetric cryptography occurred with the development of the rotor encryption/decryption machine. The electromechanical rotor enabled the development of fiendishly complex cipher systems. With the availability of computers, even more complex systems were devised, the most prominent of which was the Lucifer effort at IBM that culminated in the Data Encryption Standard (DES). But both rotor machines and DES, although representing significant advances, still relied on the bread-and-butter tools of substitution and permutation.

Public-key cryptography provides a radical departure from all that has gone before. For one thing, public-key algorithms are based on mathematical functions rather than on substitution and permutation. More important, public-key cryptography is asymmetric, involving the use of two separate keys, in contrast to symmetric encryption, which uses only one key. The use of two keys has profound consequences in the areas of confidentiality, key distribution, and authentication, as we shall see.

Before proceeding, we should mention several common misconceptions concerning public-key encryption. One such misconception is that public-key encryption is more secure from cryptanalysis than is symmetric encryption. In fact, the security of any encryption scheme depends on the length of the key and the computational work involved in breaking a cipher. There is nothing in principle about either symmetric or public-key encryption that makes one superior to another from the point of view of resisting cryptanalysis.

A second misconception is that public-key encryption is a general-purpose technique that has made symmetric encryption obsolete. On the contrary, because of the computational overhead of current public-key encryption schemes, there seems no foreseeable likelihood that symmetric encryption will be abandoned. As one of the inventors of public-key encryption has put it [DIF88], “the restriction of public-key cryptography to key management and signature applications is almost universally accepted.”

Table 9.1 Terminology Related to Asymmetric Encryption

<p>Asymmetric Keys Two related keys, a public key and a private key, that are used to perform complementary operations, such as encryption and decryption or signature generation and signature verification.</p> <p>Public Key Certificate A digital document issued and digitally signed by the private key of a Certification Authority that binds the name of a subscriber to a public key. The certificate indicates that the subscriber identified in the certificate has sole control and access to the corresponding private key.</p> <p>Public Key (Asymmetric) Cryptographic Algorithm A cryptographic algorithm that uses two related keys, a public key and a private key. The two keys have the property that deriving the private key from the public key is computationally infeasible.</p> <p>Public Key Infrastructure (PKI) A set of policies, processes, server platforms, software and workstations used for the purpose of administering certificates and public-private key pairs, including the ability to issue, maintain, and revoke public key certificates.</p>
--

Source: *Glossary of Key Information Security Terms*, NISTIR 7298.

Finally, there is a feeling that key distribution is trivial when using public-key encryption, compared to the rather cumbersome handshaking involved with key distribution centers for symmetric encryption. In fact, some form of protocol is needed, generally involving a central agent, and the procedures involved are not simpler nor any more efficient than those required for symmetric encryption (e.g., see analysis in [NEED78]).

This chapter and the next provide an overview of public-key cryptography. First, we look at its conceptual framework. Interestingly, the concept for this technique was developed and published before it was shown to be practical to adopt it. Next, we examine the RSA algorithm, which is the most important encryption/decryption algorithm that has been shown to be feasible for public-key encryption. Other important public-key cryptographic algorithms are covered in Chapter 10.

Much of the theory of public-key cryptosystems is based on number theory. If one is prepared to accept the results given in this chapter, an understanding of number theory is not strictly necessary. However, to gain a full appreciation of public-key algorithms, some understanding of number theory is required. Chapter 2 provides the necessary background in number theory.

Table 9.1 defines some key terms.

9.1 PRINCIPLES OF PUBLIC-KEY CRYPTOSYSTEMS

The concept of public-key cryptography evolved from an attempt to attack two of the most difficult problems associated with symmetric encryption. The first problem is that of key distribution, which is examined in some detail in Chapter 14.

As Chapter 14 discusses, key distribution under symmetric encryption requires either (1) that two communicants already share a key, which somehow has been distributed to them; or (2) the use of a key distribution center.

Whitfield Diffie, one of the discoverers of public-key encryption (along with Martin Hellman, both at Stanford University at the time), reasoned that this second requirement negated the very essence of cryptography: the ability to maintain total secrecy over your own communication. As Diffie put it [DIFF88], “what good would it do after all to develop impenetrable cryptosystems, if their users were forced to share their keys with a KDC that could be compromised by either burglary or subpoena?”

The second problem that Diffie pondered, and one that was apparently unrelated to the first, was that of *digital signatures*. If the use of cryptography was to become widespread, not just in military situations but for commercial and private purposes, then electronic messages and documents would need the equivalent of signatures used in paper documents. That is, could a method be devised that would stipulate, to the satisfaction of all parties, that a digital message had been sent by a particular person? This is a somewhat broader requirement than that of authentication, and its characteristics and ramifications are explored in Chapter 13.

Diffie and Hellman achieved an astounding breakthrough in 1976 [DIFF76 a, b] by coming up with a method that addressed both problems and was radically different from all previous approaches to cryptography, going back over four millennia.

In the next subsection, we look at the overall framework for public-key cryptography. Then we examine the requirements for the encryption/decryption algorithm that is at the heart of the scheme.

Public-Key Cryptosystems

Asymmetric algorithms rely on one key for encryption and a different but related key for decryption. These algorithms have the following important characteristic.

- It is computationally infeasible to determine the decryption key given only knowledge of the cryptographic algorithm and the encryption key.

In addition, some algorithms, such as RSA, also exhibit the following characteristic.

- Either of the two related keys can be used for encryption, with the other used for decryption.

A **public-key encryption** scheme has six ingredients (Figure 9.1a; compare with Figure 3.1).

- **Plaintext:** This is the readable message or data that is fed into the algorithm as input.
- **Encryption algorithm:** The encryption algorithm performs various transformations on the plaintext.
- **Public and private keys:** This is a pair of keys that have been selected so that if one is used for encryption, the other is used for decryption. The exact transformations performed by the algorithm depend on the public or private key that is provided as input.

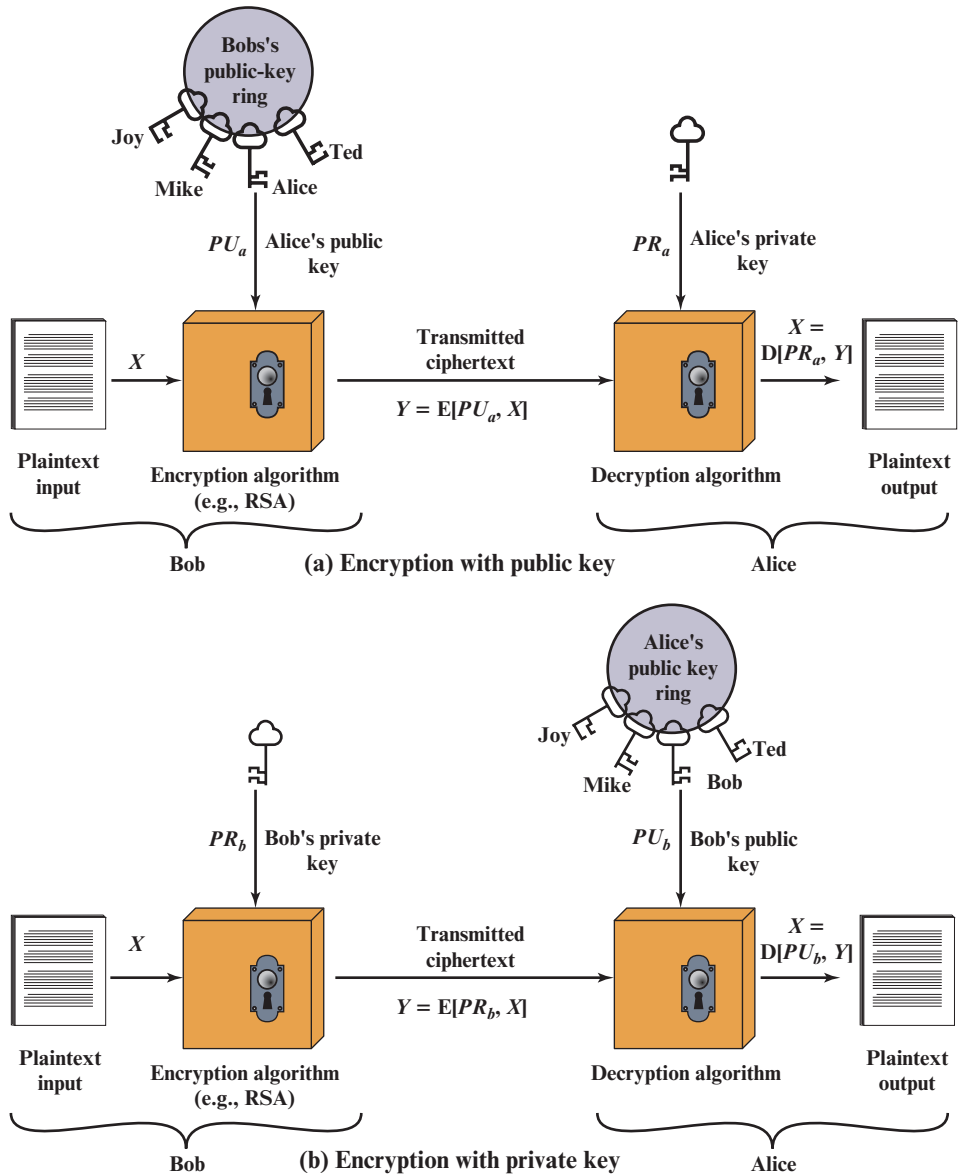

Figure 9.1 Public-Key Cryptography

- **Ciphertext:** This is the encrypted message produced as output. It depends on the plaintext and the key. For a given message, two different keys will produce two different ciphertexts.
- **Decryption algorithm:** This algorithm accepts the ciphertext and the matching key and produces the original plaintext.

The essential steps are the following.

1. Each user generates a pair of keys to be used for the encryption and decryption of messages.
2. Each user places one of the two keys in a public register or other accessible file. This is the public key. The companion key is kept private. As Figure 9.1a suggests, each user maintains a collection of public keys obtained from others.
3. If Bob wishes to send a confidential message to Alice, Bob encrypts the message using Alice's public key.
4. When Alice receives the message, she decrypts it using her private key. No other recipient can decrypt the message because only Alice knows Alice's private key.

With this approach, all participants have access to public keys, and private keys are generated locally by each participant and therefore need never be distributed. As long as a user's private key remains protected and secret, incoming communication is secure. At any time, a system can change its private key and publish the companion public key to replace its old public key.

Table 9.2 summarizes some of the important aspects of symmetric and public-key encryption. To discriminate between the two, we refer to the key used in symmetric encryption as a **secret key**. The two keys used for asymmetric encryption are referred to as the **public key** and the **private key**.¹ Invariably, the private key is kept secret, but it is referred to as a private key rather than a secret key to avoid confusion with symmetric encryption.

Let us take a closer look at the essential elements of a public-key encryption scheme, using Figure 9.2 (compare with Figure 3.2). There is some source A that produces a message in plaintext, $X = [X_1, X_2, \dots, X_M]$. The M elements of X are letters in some finite alphabet. The message is intended for destination B. B generates a related pair of keys: a public key, PU_b , and a private key, PR_b . PR_b is known only to B, whereas PU_b is publicly available and therefore accessible by A.

With the message X and the encryption key PU_b as input, A forms the ciphertext $Y = [Y_1, Y_2, \dots, Y_M]$:

$$Y = E(PU_b, X)$$

The intended receiver, in possession of the matching private key, is able to invert the transformation:

$$X = D(PR_b, Y)$$

¹The following notation is used consistently throughout. A secret key is represented by K_m , where m is some modifier; for example, K_a is a secret key owned by user A. A public key is represented by PU_a , for user A, and the corresponding private key is PR_a . Encryption of plaintext X can be performed with a secret key, a public key, or a private key, denoted by $E(K_a, X)$, $E(PU_a, X)$, and $E(PR_a, X)$, respectively. Similarly, decryption of ciphertext Y can be performed with a secret key, a public key, or a private key, denoted by $D(K_a, Y)$, $D(PU_a, Y)$, and $D(PR_a, Y)$, respectively.

Table 9.2 Conventional and Public-Key Encryption

Conventional Encryption	Public-Key Encryption
<p><i>Needed to Work:</i></p> <ol style="list-style-type: none"> 1. The same algorithm with the same key is used for encryption and decryption. 2. The sender and receiver must share the algorithm and the key. <p><i>Needed for Security:</i></p> <ol style="list-style-type: none"> 1. The key must be kept secret. 2. It must be impossible or at least impractical to decipher a message if the key is kept secret. 3. Knowledge of the algorithm plus samples of ciphertext must be insufficient to determine the key. 	<p><i>Needed to Work:</i></p> <ol style="list-style-type: none"> 1. One algorithm is used for encryption and a related algorithm for decryption with a pair of keys, one for encryption and one for decryption. 2. The sender and receiver must each have one of the matched pair of keys (not the same one). <p><i>Needed for Security:</i></p> <ol style="list-style-type: none"> 1. One of the two keys must be kept secret. 2. It must be impossible or at least impractical to decipher a message if one of the keys is kept secret. 3. Knowledge of the algorithm plus one of the keys plus samples of ciphertext must be insufficient to determine the other key.

An adversary, observing Y and having access to PU_b , but not having access to PR_b or X , must attempt to recover X and/or PR_b . It is assumed that the adversary does have knowledge of the encryption (E) and decryption (D) algorithms. If the adversary is interested only in this particular message, then the focus of effort is to recover X by generating a plaintext estimate \hat{X} . Often, however, the adversary is interested in being able to read future messages as well, in which case an attempt is made to recover PR_b by generating an estimate \hat{PR}_b .

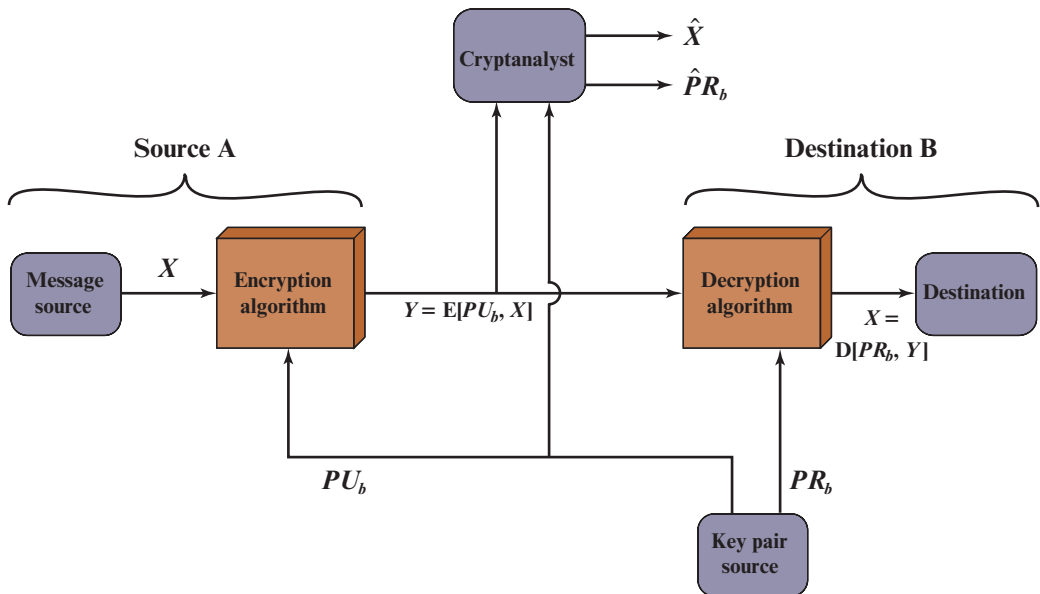

Figure 9.2 Public-Key Cryptosystem: Confidentiality

We mentioned earlier that either of the two related keys can be used for encryption, with the other being used for decryption. This enables a rather different cryptographic scheme to be implemented. Whereas the scheme illustrated in Figure 9.2 provides confidentiality, Figures 9.1b and 9.3 show the use of public-key encryption to provide authentication:

$$Y = E(PR_a, X)$$

$$X = D(PU_a, Y)$$

In this case, A prepares a message to B and encrypts it using A's private key before transmitting it. B can decrypt the message using A's public key. Because the message was encrypted using A's private key, only A could have prepared the message. Therefore, the entire encrypted message serves as a **digital signature**. In addition, it is impossible to alter the message without access to A's private key, so the message is authenticated both in terms of source and in terms of data integrity.

In the preceding scheme, the entire message is encrypted, which, although validating both author and contents, requires a great deal of storage. Each document must be kept in plaintext to be used for practical purposes. A copy also must be stored in ciphertext so that the origin and contents can be verified in case of a dispute. A more efficient way of achieving the same results is to encrypt a small block of bits that is a function of the document. Such a block, called an authenticator, must have the property that it is infeasible to change the document without changing the authenticator. If the authenticator is encrypted with the sender's private key, it serves as a signature that verifies origin, content, and sequencing. Chapter 13 examines this technique in detail.

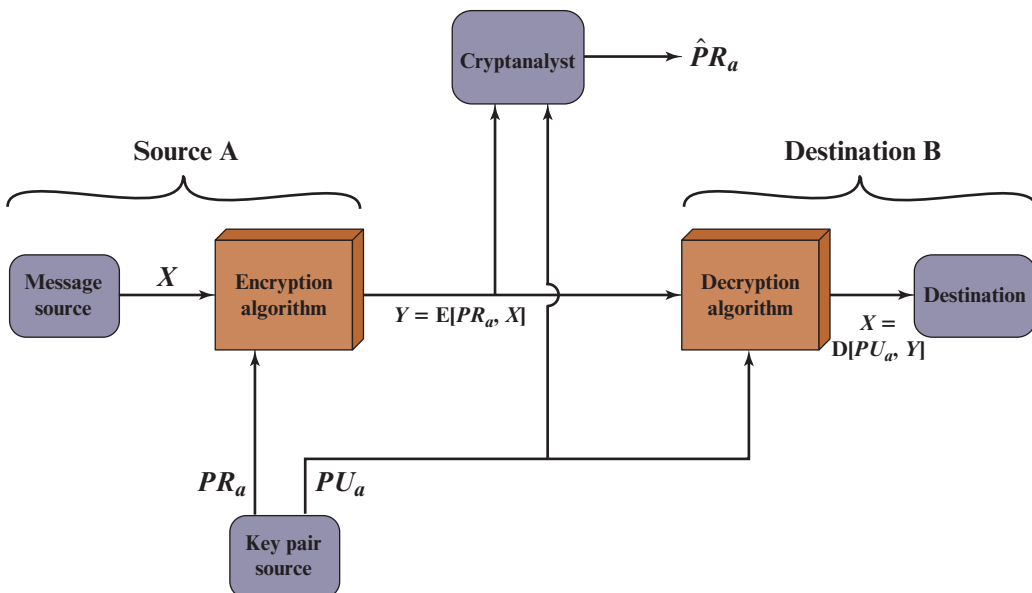

Figure 9.3 Public-Key Cryptosystem: Authentication

It is important to emphasize that the encryption process depicted in Figures 9.1b and 9.3 does not provide confidentiality. That is, the message being sent is safe from alteration but not from eavesdropping. This is obvious in the case of a signature based on a portion of the message, because the rest of the message is transmitted in the clear. Even in the case of complete encryption, as shown in Figure 9.3, there is no protection of confidentiality because any observer can decrypt the message by using the sender's public key.

It is, however, possible to provide both the authentication function and confidentiality by a double use of the public-key scheme (Figure 9.4):

$$Z = E(PU_b, E(PR_a, X))$$

$$X = D(PU_a, D(PR_b, Z))$$

In this case, we begin as before by encrypting a message, using the sender's private key. This provides the digital signature. Next, we encrypt again, using the receiver's public key. The final ciphertext can be decrypted only by the intended receiver, who alone has the matching private key. Thus, confidentiality is provided. The disadvantage of this approach is that the public-key algorithm, which is complex, must be exercised four times rather than two in each communication.

Applications for Public-Key Cryptosystems

Before proceeding, we need to clarify one aspect of public-key cryptosystems that is otherwise likely to lead to confusion. Public-key systems are characterized by the use of a cryptographic algorithm with two keys, one held private and one available publicly. Depending on the application, the sender uses either the sender's private key or the receiver's public key, or both, to perform some type of cryptographic

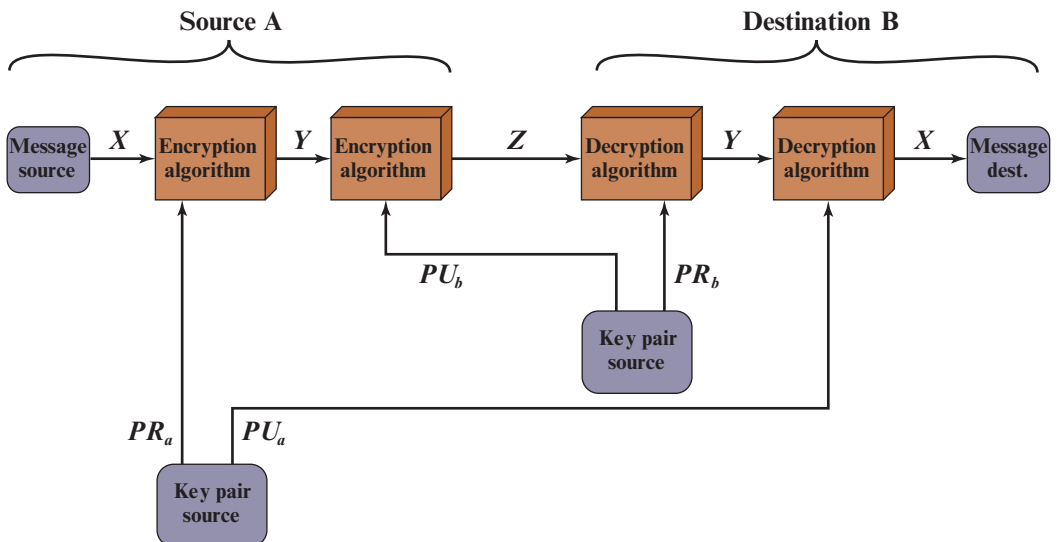

Figure 9.4 Public-Key Cryptosystem: Authentication and Secrecy

function. In broad terms, we can classify the use of public-key cryptosystems into three categories

- **Encryption/decryption:** The sender encrypts a message with the recipient's public key, and the recipient decrypts the message with the recipient's private key.
- **Digital signature:** The sender "signs" a message with its private key. Signing is achieved by a cryptographic algorithm applied to the message or to a small block of data that is a function of the message.
- **Key exchange:** Two sides cooperate to exchange a session key, which is a secret key for symmetric encryption generated for use for a particular transaction (or session) and valid for a short period of time. Several different approaches are possible, involving the private key(s) of one or both parties; this is discussed in Chapter 10.

Some algorithms are suitable for all three applications, whereas others can be used only for one or two of these applications. Table 9.3 indicates the applications supported by the algorithms discussed in this book.

Requirements for Public-Key Cryptography

The cryptosystem illustrated in Figures 9.2 through 9.4 depends on a cryptographic algorithm based on two related keys. Diffie and Hellman postulated this system without demonstrating that such algorithms exist. However, they did lay out the conditions that such algorithms must fulfill [DIFF76b].

1. It is computationally easy for a party B to generate a key pair (public key PU_b , private key PR_b).
2. It is computationally easy for a sender A, knowing the public key and the message to be encrypted, M , to generate the corresponding ciphertext:

$$C = E(PU_b, M)$$

3. It is computationally easy for the receiver B to decrypt the resulting ciphertext using the private key to recover the original message:

$$M = D(PR_b, C) = D[PR_b, E(PU_b, M)]$$

4. It is computationally infeasible for an adversary, knowing the public key, PU_b , to determine the private key, PR_b .

Table 9.3 Applications for Public-Key Cryptosystems

Algorithm	Encryption/Decryption	Digital Signature	Key Exchange
RSA	Yes	Yes	Yes
Elliptic Curve	Yes	Yes	Yes
Diffie–Hellman	No	No	Yes
DSS	No	Yes	No

5. It is computationally infeasible for an adversary, knowing the public key, PU_b , and a ciphertext, C , to recover the original message, M .

We can add a sixth requirement that, although useful, is not necessary for all public-key applications:

6. The two keys can be applied in either order:

$$M = D[PU_b, E(PR_b, M)] = D[PR_b, E(PU_b, M)]$$

These are formidable requirements, as evidenced by the fact that only a few algorithms (RSA, elliptic curve cryptography, Diffie–Hellman, DSS) have received widespread acceptance in the several decades since the concept of public-key cryptography was proposed.

Before elaborating on why the requirements are so formidable, let us first recast them. The requirements boil down to the need for a trap-door one-way function. A **one-way function**² is one that maps a domain into a range such that every function value has a unique inverse, with the condition that the calculation of the function is easy, whereas the calculation of the inverse is infeasible:

$$\begin{aligned} Y &= f(X) && \text{easy} \\ X &= f^{-1}(Y) && \text{infeasible} \end{aligned}$$

Generally, *easy* is defined to mean a problem that can be solved in polynomial time as a function of input length. Thus, if the length of the input is n bits, then the time to compute the function is proportional to n^a , where a is a fixed constant. Such algorithms are said to belong to the class **P**. The term *infeasible* is a much fuzzier concept. In general, we can say a problem is infeasible if the effort to solve it grows faster than polynomial time as a function of input size. For example, if the length of the input is n bits and the time to compute the function is proportional to 2^n , the problem is considered infeasible. Unfortunately, it is difficult to determine if a particular algorithm exhibits this complexity. Furthermore, traditional notions of computational complexity focus on the worst-case or average-case complexity of an algorithm. These measures are inadequate for cryptography, which requires that it be infeasible to invert a function for virtually all inputs, not for the worst case or even average case. [LAI18] provides an excellent introduction to complexity.

We now turn to the definition of a trap-door one-way function, which is easy to calculate in one direction and infeasible to calculate in the other direction unless certain additional information is known. With the additional information the inverse can be calculated in polynomial time. We can summarize as follows: A trap-door one-way function is a family of invertible functions f_k , such that

$$\begin{aligned} Y &= f_k(X) && \text{easy, if } k \text{ and } X \text{ are known} \\ X &= f_k^{-1}(Y) && \text{easy, if } k \text{ and } Y \text{ are known} \\ X &= f_k^{-1}(Y) && \text{infeasible, if } Y \text{ is known but } k \text{ is not known} \end{aligned}$$

²Not to be confused with a one-way hash function, which takes an arbitrarily large data field as its argument and maps it to a fixed output. Such functions are used for authentication (see Chapter 11).

Thus, the development of a practical public-key scheme depends on discovery of a suitable trap-door one-way function.

Public-Key Cryptanalysis

As with symmetric encryption, a public-key encryption scheme is vulnerable to a brute-force attack. The countermeasure is the same: Use large keys. However, there is a tradeoff to be considered. Public-key systems depend on the use of some sort of invertible mathematical function. The complexity of calculating these functions may not scale linearly with the number of bits in the key but grow more rapidly than that. Thus, the key size must be large enough to make brute-force attack impractical but small enough for practical encryption and decryption. In practice, the key sizes that have been proposed do make brute-force attack impractical but result in encryption/decryption speeds that are too slow for general-purpose use. Instead, as was mentioned earlier, public-key encryption is currently confined to key management and signature applications.

Another form of attack is to find some way to compute the private key given the public key. To date, it has not been mathematically proven that this form of attack is infeasible for a particular public-key algorithm. Thus, any given algorithm, including the widely used RSA algorithm, is suspect. The history of cryptanalysis shows that a problem that seems insoluble from one perspective can be found to have a solution if looked at in an entirely different way.

Finally, there is a form of attack that is peculiar to public-key systems. This is, in essence, a probable-message attack. Suppose, for example, that a message were to be sent that consisted solely of a 56-bit DES key. An adversary could encrypt all possible 56-bit DES keys using the public key and could discover the encrypted key by matching the transmitted ciphertext. Thus, no matter how large the key size of the public-key scheme, the attack is reduced to a brute-force attack on a 56-bit key. This attack can be thwarted by appending some random bits to such simple messages.

9.2 THE RSA ALGORITHM

The pioneering paper by Diffie and Hellman [DIFF76b] introduced a new approach to cryptography and, in effect, challenged cryptologists to come up with a cryptographic algorithm that met the requirements for public-key systems. One of the first successful responses to the challenge was developed in 1977 by Ron Rivest, Adi Shamir, and Len Adleman at MIT and first published in 1978 [RIVE78]. The Rivest-Shamir-Adleman (RSA) scheme has since that time reigned supreme as the most widely accepted and implemented general-purpose approach to public-key encryption.

The **RSA** scheme is a cipher in which the plaintext and ciphertext are integers between 0 and $n - 1$ for some n . A typical size for n is 1024 bits, or 309 decimal digits. That is, n is less than 2^{1024} . We examine RSA in this section in some detail,

beginning with an explanation of the algorithm. Then we examine some of the computational and cryptanalytical implications of RSA.

Description of the Algorithm

RSA makes use of an expression with exponentials. Plaintext is encrypted in blocks, with each block having a binary value less than some number n . That is, the block size must be less than or equal to $\log_2(n) + 1$; in practice, the block size is i bits, where $2^i < n \leq 2^{i+1}$. Encryption and decryption are of the following form, for some plaintext block M and ciphertext block C .

$$\begin{aligned} C &= M^e \bmod n \\ M &= C^d \bmod n = (M^e)^d \bmod n = M^{ed} \bmod n \end{aligned}$$

Both sender and receiver must know the value of n . The sender knows the value of e , and only the receiver knows the value of d . Thus, this is a public-key encryption algorithm with a public key of $PU = \{e, n\}$ and a private key of $PR = \{d, n\}$. For this algorithm to be satisfactory for public-key encryption, the following requirements must be met.

1. It is possible to find values of e, d , and n such that $M^{ed} \bmod n = M$ for all $M < n$.
2. It is relatively easy to calculate $M^e \bmod n$ and $C^d \bmod n$ for all values of $M < n$.
3. It is infeasible to determine d given e and n .

For now, we focus on the first requirement and consider the other questions later. We need to find a relationship of the form

$$M^{ed} \bmod n = M$$

The preceding relationship holds if e and d are multiplicative inverses modulo $\phi(n)$, where $\phi(n)$ is the Euler totient function. It is shown in Chapter 2 that for p, q prime, $\phi(pq) = (p - 1)(q - 1)$. The relationship between e and d can be expressed as

$$ed \bmod \phi(n) = 1 \tag{9.1}$$

This is equivalent to saying

$$\begin{aligned} ed &\equiv 1 \bmod \phi(n) \\ d &\equiv e^{-1} \bmod \phi(n) \end{aligned}$$

That is, e and d are multiplicative inverses mod $\phi(n)$. Note that, according to the rules of modular arithmetic, this is true only if d (and therefore e) is relatively prime to $\phi(n)$. Equivalently, $\gcd(\phi(n), d) = 1$. A proof that Equation (9.1) satisfies the requirement for RSA can be found in the original RSA paper [RIVE78].

We are now ready to state the RSA scheme. The ingredients are the following:

p, q , two prime numbers	(private, chosen)
$n = pq$	(public, calculated)
e , with $\gcd(\phi(n), e) = 1; 1 < e < \phi(n)$	(public, chosen)
$d \equiv e^{-1} \pmod{\phi(n)}$	(private, calculated)

The private key consists of $\{d, n\}$ and the public key consists of $\{e, n\}$. Suppose that user A has published its public key and that user B wishes to send the message M to A. Then B calculates $C = M^e \bmod n$ and transmits C . On receipt of this ciphertext, user A decrypts by calculating $M = C^d \bmod n$.

Figure 9.5 summarizes the RSA algorithm. It corresponds to Figure 9.1a: Alice generates a public/private key pair; Bob encrypts using Alice's public key; and Alice decrypts using her private key. An example from [SING99] is shown in Figure 9.6. For this example, the keys were generated as follows.

1. Select two prime numbers, $p = 17$ and $q = 11$.
2. Calculate $n = pq = 17 \times 11 = 187$.
3. Calculate $\phi(n) = (p - 1)(q - 1) = 16 \times 10 = 160$.
4. Select e such that e is relatively prime to $\phi(n) = 160$ and less than $\phi(n)$; we choose $e = 7$.
5. Determine d such that $de \equiv 1 \pmod{160}$ and $d < 160$. The correct value is $d = 23$, because $23 \times 7 = 161 = (1 \times 160) + 1$; d can be calculated using the extended Euclid's algorithm (Chapter 2).

The resulting keys are public key $PU = \{7, 187\}$ and private key $PR = \{23, 187\}$. The example shows the use of these keys for a plaintext input of $M = 88$. For encryption, we need to calculate $C = 88^7 \bmod 187$. Exploiting the properties of modular arithmetic, we can do this as follows.

$$88^7 \bmod 187 = [(88^4 \bmod 187) \times (88^2 \bmod 187) \times (88^1 \bmod 187)] \bmod 187$$

$$88^1 \bmod 187 = 88$$

$$88^2 \bmod 187 = 7744 \bmod 187 = 77$$

$$88^4 \bmod 187 = 59,969,536 \bmod 187 = 132$$

$$88^7 \bmod 187 = (88 \times 77 \times 132) \bmod 187 = 894,432 \bmod 187 = 11$$

For decryption, we calculate $M = 11^{23} \bmod 187$:

$$11^{23} \bmod 187 = [(11^1 \bmod 187) \times (11^2 \bmod 187) \times (11^4 \bmod 187) \times (11^8 \bmod 187) \times (11^8 \bmod 187)] \bmod 187$$

$$11^1 \bmod 187 = 11$$

$$11^2 \bmod 187 = 121$$

$$11^4 \bmod 187 = 14,641 \bmod 187 = 55$$

$$11^8 \bmod 187 = 214,358,881 \bmod 187 = 33$$

$$11^{23} \bmod 187 = (11 \times 121 \times 55 \times 33 \times 33) \bmod 187 = 79,720,245 \bmod 187 = 88$$

We now look at an example from [HELL79], which shows the use of RSA to process multiple blocks of data. In this simple example, the plaintext is an alphanumeric string. Each plaintext symbol is assigned a unique code of two decimal

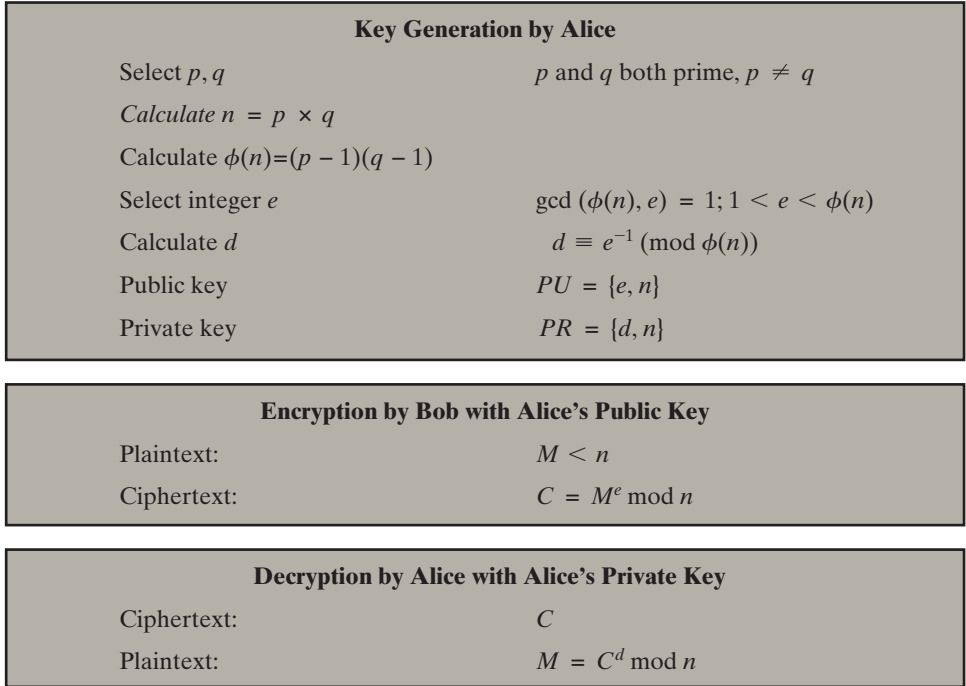

Figure 9.5 The RSA Algorithm

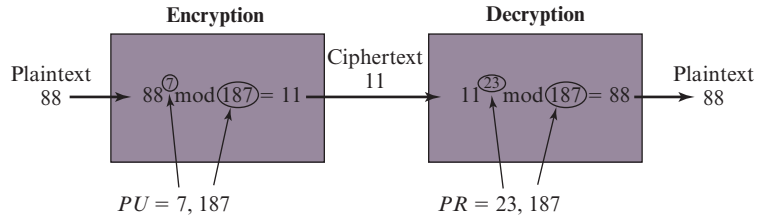

Figure 9.6 Example of RSA Algorithm

digits (e.g., $a = 00, A = 26$).³ A plaintext block consists of four decimal digits, or two alphanumeric characters. Figure 9.7a illustrates the sequence of events for the encryption of multiple blocks, and Figure 9.7b gives a specific example. The circled numbers indicate the order in which operations are performed.

Computational Aspects

We now turn to the issue of the complexity of the computation required to use RSA. There are actually two issues to consider: encryption/decryption and key generation. Let us look first at the process of encryption and decryption and then consider key generation.

³The complete mapping of alphanumeric characters to decimal digits is at box.com/Crypto8e in the document [RSAexample.pdf](#).

However, we can achieve the same final result with only four multiplications if we repeatedly take the square of each partial result, successively forming (x^2, x^4, x^8, x^{16}) . As another example, suppose we wish to calculate $x^{11} \bmod n$ for some integers x and n . Observe that $x^{11} = x^{1+2+8} = (x)(x^2)(x^8)$. In this case, we compute $x \bmod n$, $x^2 \bmod n$, $x^4 \bmod n$, and $x^8 \bmod n$ and then calculate $[(x \bmod n) \times (x^2 \bmod n) \times (x^8 \bmod n)] \bmod n$.

More generally, suppose we wish to find the value $a^b \bmod n$ with a , b , and m positive integers. If we express b as a binary number $b_k b_{k-1} \dots b_0$, then we have

$$b = \sum_{b_i \neq 0} 2^i$$

Therefore,

$$a^b = a^{\left(\sum_{b_i \neq 0} 2^i\right)} = \prod_{b_i \neq 0} a^{(2^i)}$$

$$a^b \bmod n = \left[\prod_{b_i \neq 0} a^{(2^i)} \right] \bmod n = \left(\prod_{b_i \neq 0} \left[a^{(2^i)} \bmod n \right] \right) \bmod n$$

We can therefore develop the algorithm⁴ for computing $a^b \bmod n$, shown in Figure 9.8. Table 9.4 shows an example of the execution of this algorithm. Note that the variable c is not needed; it is included for explanatory purposes. The final value of c is the value of the exponent.

EFFICIENT OPERATION USING THE PUBLIC KEY To speed up the operation of the RSA algorithm using the public key, a specific choice of e is usually made. The most common choice is 65537 ($2^{16} + 1$); two other popular choices are 3 and 17. Each of these choices has only two 1 bits, so the number of multiplications required to perform exponentiation is minimized.

```

c ← 0; f ← 1
for i ← k downto 0
  do c ← 2 × c
     f ← (f × f) mod n
  if bi = 1
    then c ← c + 1
        f ← (f × a) mod n
return f

```

Note: The integer b is expressed as a binary number $b_k b_{k-1} \dots b_0$.

Figure 9.8 Algorithm for Computing $a^b \bmod n$

⁴The algorithm has a long history; this particular pseudocode expression is from [CORM09].

Table 9.4 Result of the Fast Modular Exponentiation Algorithm for $a^b \bmod n$, where $a = 7$, $b = 560 = 1000110000$, and $n = 561$

i	9	8	7	6	5	4	3	2	1	0
b_i	1	0	0	0	1	1	0	0	0	0
c	1	2	4	8	17	35	70	140	280	560
f	7	49	157	526	160	241	298	166	67	1

However, with a very small public key, such as $e = 3$, RSA becomes vulnerable to a simple attack. Suppose we have three different RSA users who all use the value $e = 3$ but have unique values of n , namely (n_1, n_2, n_3) . If user A sends the same encrypted message M to all three users, then the three ciphertexts are $C_1 = M^3 \bmod n_1$, $C_2 = M^3 \bmod n_2$, and $C_3 = M^3 \bmod n_3$. It is likely that n_1, n_2 , and n_3 are pairwise relatively prime. Therefore, one can use the Chinese remainder theorem (CRT) to compute $M^3 \bmod (n_1 n_2 n_3)$. By the rules of the RSA algorithm, M is less than each of the n_i ; therefore $M^3 < n_1 n_2 n_3$. Accordingly, the attacker need only compute the cube root of M^3 . This attack can be countered by adding a unique pseudorandom bit string as padding to each instance of M to be encrypted. This approach is discussed subsequently.

The reader may have noted that the definition of the RSA algorithm (Figure 9.5) requires that during key generation the user selects a value of e that is relatively prime to $\phi(n)$. Thus, if a value of e is selected first and the primes p and q are generated, it may turn out that $\gcd(\phi(n), e) \neq 1$. In that case, the user must reject the p, q values and generate a new p, q pair.

EFFICIENT OPERATION USING THE PRIVATE KEY We cannot similarly choose a small constant value of d for efficient operation. A small value of d is vulnerable to a brute-force attack and to other forms of cryptanalysis [WIEN90]. However, there is a way to speed up computation using the CRT. We wish to compute the value $M = C^d \bmod n$. Let us define the following intermediate results:

$$V_p = C^d \bmod p \quad V_q = C^d \bmod q$$

Following the CRT using Equation (8.8), define the quantities

$$X_p = q \times (q^{-1} \bmod p) \quad X_q = p \times (p^{-1} \bmod q)$$

The CRT then shows, using Equation (8.9), that

$$M = (V_p X_p + V_q X_q) \bmod n$$

Furthermore, we can simplify the calculation of V_p and V_q using Fermat's theorem, which states that $a^{p-1} \equiv 1 \pmod{p}$ if p and a are relatively prime. Some thought should convince you that the following are valid.

$$V_p = C^d \bmod p = C^{d \bmod (p-1)} \bmod p \quad V_q = C^d \bmod q = C^{d \bmod (q-1)} \bmod q$$

The quantities $d \bmod (p - 1)$ and $d \bmod (q - 1)$ can be precalculated. The end result is that the calculation is approximately four times as fast as evaluating $M = C^d \bmod n$ directly [BONE02].

KEY GENERATION Before the application of the public-key cryptosystem, each participant must generate a pair of keys. This involves the following tasks.

- Determining two prime numbers, p and q .
- Selecting either e or d and calculating the other.

First, consider the selection of p and q . Because the value of $n = pq$ will be known to any potential adversary, in order to prevent the discovery of p and q by exhaustive methods, these primes must be chosen from a sufficiently large set (i.e., p and q must be large numbers). On the other hand, the method used for finding large primes must be reasonably efficient.

At present, there are no useful techniques that yield arbitrarily large primes, so some other means of tackling the problem is needed. The procedure that is generally used is to pick at random an odd number of the desired order of magnitude and test whether that number is prime. If not, pick successive random numbers until one is found that tests prime.

A variety of tests for primality have been developed (e.g., see [KNUT98] for a description of a number of such tests). Almost invariably, the tests are probabilistic. That is, the test will merely determine that a given integer is *probably* prime. Despite this lack of certainty, these tests can be run in such a way as to make the probability as close to 1.0 as desired. As an example, one of the more efficient and popular algorithms, the Miller–Rabin algorithm, is described in Chapter 2. With this algorithm and most such algorithms, the procedure for testing whether a given integer n is prime is to perform some calculation that involves n and a randomly chosen integer a . If n “fails” the test, then n is not prime. If n “passes” the test, then n may be prime or nonprime. If n passes many such tests with many different randomly chosen values for a , then we can have high confidence that n is, in fact, prime.

In summary, the procedure for picking a prime number is as follows.

1. Pick an odd integer n at random (e.g., using a pseudorandom number generator).
2. Pick an integer $a < n$ at random.
3. Perform the probabilistic primality test, such as Miller–Rabin, with a as a parameter. If n fails the test, reject the value n and go to step 1.
4. If n has passed a sufficient number of tests, accept n ; otherwise, go to step 2.

This is a somewhat tedious procedure. However, remember that this process is performed relatively infrequently: only when a new pair (PU , PR) is needed.

It is worth noting how many numbers are likely to be rejected before a prime number is found. A result from number theory, known as the prime number theorem, states that the primes near N are spaced on the average one every

$\ln(N)$ integers. Thus, on average, one would have to test on the order of $\ln(N)$ integers before a prime is found. Actually, because all even integers can be immediately rejected, the correct figure is $\ln(N)/2$. For example, if a prime on the order of magnitude of 2^{200} were sought, then about $\ln(2^{200})/2 = 70$ trials would be needed to find a prime.

Having determined prime numbers p and q , the process of key generation is completed by selecting a value of e and calculating d or, alternatively, selecting a value of d and calculating e . Assuming the former, then we need to select an e such that $\gcd(\phi(n), e) = 1$ and then calculate $d \equiv e^{-1} \pmod{\phi(n)}$. Fortunately, there is a single algorithm that will, at the same time, calculate the greatest common divisor of two integers and, if the gcd is 1, determine the inverse of one of the integers modulo the other. The algorithm, referred to as the extended Euclid's algorithm, is explained in Chapter 2. Thus, the procedure is to generate a series of random numbers, testing each against $\phi(n)$ until a number relatively prime to $\phi(n)$ is found. Again, we can ask the question: How many random numbers must we test to find a usable number, that is, a number relatively prime to $\phi(n)$? It can be shown easily that the probability that two random numbers are relatively prime is about 0.6; thus, very few tests would be needed to find a suitable integer (see Problem 2.18).

The Security of RSA

Five possible approaches to attacking the RSA algorithm are:

- **Brute force:** This involves trying all possible private keys.
- **Mathematical attacks:** There are several approaches, all equivalent in effort to factoring the product of two primes.
- **Timing attacks:** These depend on the running time of the decryption algorithm.
- **Hardware fault-based attack:** This involves inducing hardware faults in the processor that is generating digital signatures.
- **Chosen ciphertext attacks:** This type of attack exploits properties of the RSA algorithm.

The defense against the brute-force approach is the same for RSA as for other cryptosystems, namely, to use a large key space. Thus, the larger the number of bits in d , the better. However, because the calculations involved, both in key generation and in encryption/decryption, are complex, the larger the size of the key, the slower the system will run.

In this subsection, we provide an overview of mathematical and timing attacks.

THE FACTORING PROBLEM We can identify three approaches to attacking RSA mathematically.

1. Factor n into its two prime factors. This enables calculation of $\phi(n) = (p - 1) \times (q - 1)$, which in turn enables determination of $d \equiv e^{-1} \pmod{\phi(n)}$.
2. Determine $\phi(n)$ directly, without first determining p and q . Again, this enables determination of $d \equiv e^{-1} \pmod{\phi(n)}$.
3. Determine d directly, without first determining $\phi(n)$.

Most discussions of the cryptanalysis of RSA have focused on the task of factoring n into its two prime factors. Determining $\phi(n)$ given n is equivalent to factoring n [RIBE96]. With presently known algorithms, determining d given e and n appears to be at least as time-consuming as the factoring problem [KALI95]. Hence, we can use factoring performance as a benchmark against which to evaluate the security of RSA.

For a large n with large prime factors, factoring is a hard problem, but it is not as hard as it used to be. A striking illustration of this is the following. In 1977, the three inventors of RSA dared *Scientific American* readers to decode a cipher they printed in Martin Gardner's "Mathematical Games" column [GARD77]. They offered a \$100 reward for the return of a plaintext sentence, an event they predicted might not occur for some 40 quadrillion years. In April of 1994, a group working over the Internet claimed the prize after only eight months of work [LEUT94]. This challenge used a public key size (length of n) of 129 decimal digits, or around 428 bits. In the meantime, just as they had done for DES, RSA Laboratories had issued challenges for the RSA cipher with key sizes of 100, 110, 120, and so on, digits. The latest challenge to be met is the RSA-768 challenge with a key length of 232 decimal digits, or 768 bits.

A striking fact about the factoring of the successive challenges concerns the method used. Until the mid-1990s, factoring attacks were made using an approach known as the quadratic sieve. The attack on RSA-130 used a newer algorithm, the generalized number field sieve (GNFS), and was able to factor a larger number than RSA-129 at only 20% of the computing effort.

The threat to larger key sizes is twofold: the continuing increase in computing power and the continuing refinement of factoring algorithms. We have seen that the move to a different algorithm resulted in a tremendous speedup. We can expect further refinements in the GNFS, and the use of an even better algorithm is also a possibility. In fact, a related algorithm, the special number field sieve (SNFS), can factor numbers with a specialized form considerably faster than the generalized number field sieve. It is reasonable to expect a breakthrough that would enable a general factoring performance in about the same time as SNFS, or even better [ODLY95]. Thus, we need to be careful in choosing a key size for RSA. The team that produced the 768-bit factorization [KLEI10] observed that factoring a 1024-bit RSA modulus would be about a thousand times harder than factoring a 768-bit modulus, and a 768-bit RSA modulus is several thousands times harder to factor than a 512-bit one. Based on the amount of time between the 512-bit and 768-bit factorization successes, the team felt it to be reasonable to expect that the 1024-bit RSA moduli could be factored well within the next decade by a similar academic effort. Thus, they recommended phasing out usage of 1024-bit RSA within the next few years (from 2010).

A number of government agencies have issued recommendations for RSA key size:

- NIST SP 800-131A (*Transitions: Recommendation for Transitioning the Use of Cryptographic Algorithms and Key Lengths*, November 2015) recommends a key length of 2048 bits or longer.
- The European Union Agency for Network and Information Security, in *Algorithms, Key Size and Parameters Report – 2014* recommends a key length of 3072 bits or longer for all new development.

- The government of Canada's Communications Security Establishment, in *Cryptographic Algorithms for UNCLASSIFIED, PROTECTED A, and PROTECTED B Information* (August 2016) recommends a length of at least 2048 bits, extended to at least 3072 bits by 2030.

In addition to specifying the size of n , a number of other constraints have been suggested by researchers. To avoid values of n that may be factored more easily, the algorithm's inventors suggest the following constraints on p and q .

1. p and q should differ in length by only a few digits. Thus, for a 1024-bit key (309 decimal digits), both p and q should be on the order of magnitude of 10^{75} to 10^{100} .
2. Both $(p - 1)$ and $(q - 1)$ should contain a large prime factor.
3. $\gcd(p - 1, q - 1)$ should be small.

In addition, it has been demonstrated that if $e < n$ and $d < n^{1/4}$, then d can be easily determined [WIEN90].

TIMING ATTACKS If one needed yet another lesson about how difficult it is to assess the security of a cryptographic algorithm, the appearance of timing attacks provides a stunning one. Paul Kocher, a cryptographic consultant, demonstrated that a snooper can determine a private key by keeping track of how long a computer takes to decipher messages [KOCH96, KALI96b]. Timing attacks are applicable not just to RSA, but to other public-key cryptography systems. This attack is alarming for two reasons: It comes from a completely unexpected direction, and it is a ciphertext-only attack.

A **timing attack** is somewhat analogous to a burglar guessing the combination of a safe by observing how long it takes for someone to turn the dial from number to number. We can explain the attack using the modular exponentiation algorithm of Figure 9.8, but the attack can be adapted to work with any implementation that does not run in fixed time. In this algorithm, modular exponentiation is accomplished bit by bit, with one modular multiplication performed at each iteration and an additional modular multiplication performed for each 1 bit.

As Kocher points out in his paper, the attack is simplest to understand in an extreme case. Suppose the target system uses a modular multiplication function that is very fast in almost all cases but in a few cases takes much more time than an entire average modular exponentiation. The attack proceeds bit-by-bit starting with the leftmost bit, b_k . Suppose that the first j bits are known (to obtain the entire exponent, start with $j = 0$ and repeat the attack until the entire exponent is known). For a given ciphertext, the attacker can complete the first j iterations of the **for** loop. The operation of the subsequent step depends on the unknown exponent bit. If the bit is set, $d \leftarrow (d \times a) \bmod n$ will be executed. For a few values of a and d , the modular multiplication will be extremely slow, and the attacker knows which these are. Therefore, if the observed time to execute the decryption algorithm is always slow when this particular iteration is slow with a 1 bit, then this bit is assumed to be 1. If a number of observed execution times for the entire algorithm are fast, then this bit is assumed to be 0.

In practice, modular exponentiation implementations do not have such extreme timing variations, in which the execution time of a single iteration can exceed the mean execution time of the entire algorithm. Nevertheless, there is enough variation to make this attack practical. For details, see [KOCH96].

Although the timing attack is a serious threat, there are simple countermeasures that can be used, including the following.

- **Constant exponentiation time:** Ensure that all exponentiations take the same amount of time before returning a result. This is a simple fix but does degrade performance.
- **Random delay:** Better performance could be achieved by adding a random delay to the exponentiation algorithm to confuse the timing attack. Kocher points out that if defenders don't add enough noise, attackers could still succeed by collecting additional measurements to compensate for the random delays.
- **Blinding:** Multiply the ciphertext by a random number before performing exponentiation. This process prevents the attacker from knowing what ciphertext bits are being processed inside the computer and therefore prevents the bit-by-bit analysis essential to the timing attack.

RSA Data Security incorporates a blinding feature into some of its products. The private-key operation $M = C^d \bmod n$ is implemented as follows.

1. Generate a secret random number r between 0 and $n - 1$.
2. Compute $C' = C(r^e) \bmod n$, where e is the public exponent.
3. Compute $M' = (C')^d \bmod n$ with the ordinary RSA implementation.
4. Compute $M = M'r^{-1} \bmod n$. In this equation, r^{-1} is the multiplicative inverse of $r \bmod n$; see Chapter 2 for a discussion of this concept. It can be demonstrated that this is the correct result by observing that $r^{ed} \bmod n = r \bmod n$.

RSA Data Security reports a 2 to 10% performance penalty for blinding.

FAULT-BASED ATTACK Still another unorthodox approach to attacking RSA is reported in [PELL10]. The approach is an attack on a processor that is generating RSA digital signatures. The attack induces faults in the signature computation by reducing the power to the processor. The faults cause the software to produce invalid signatures, which can then be analyzed by the attacker to recover the private key. The authors show how such an analysis can be done and then demonstrate it by extracting a 1024-bit private RSA key in approximately 100 hours, using a commercially available microprocessor.

The attack algorithm involves inducing single-bit errors and observing the results. The details are provided in [PELL10], which also references other proposed hardware fault-based attacks against RSA.

This attack, while worthy of consideration, does not appear to be a serious threat to RSA. It requires that the attacker have physical access to the target machine and that the attacker is able to directly control the input power to the

processor. Controlling the input power would for most hardware require more than simply controlling the AC power, but would also involve the power supply control hardware on the chip.

CHOSEN CIPHERTEXT ATTACK AND OPTIMAL ASYMMETRIC ENCRYPTION PADDING The basic RSA algorithm is vulnerable to a chosen ciphertext attack (CCA). CCA is defined as an attack in which the adversary chooses a number of ciphertexts and is then given the corresponding plaintexts, decrypted with the target's private key. Thus, the adversary could select a plaintext, encrypt it with the target's public key, and then be able to get the plaintext back by having it decrypted with the private key. Clearly, this provides the adversary with no new information. Instead, the adversary exploits properties of RSA and selects blocks of data that, when processed using the target's private key, yield information needed for cryptanalysis.

A simple example of a CCA against RSA takes advantage of the following property of RSA:

$$E(PU, M_1) \times E(PU, M_2) = E(PU, [M_1 \times M_2]) \quad (9.2)$$

We can decrypt $C = M^e \bmod n$ using a CCA as follows.

1. Compute $X = (C \times 2^e) \bmod n$.
2. Submit X as a chosen ciphertext and receive back $Y = X^d \bmod n$.

But now note that

$$\begin{aligned} X &= (C \bmod n) \times (2^e \bmod n) \\ &= (M^e \bmod n) \times (2^e \bmod n) \\ &= (2M)^e \bmod n \end{aligned}$$

Therefore, $Y = (2M) \bmod n$. From this, we can deduce M . To overcome this simple attack, practical RSA-based cryptosystems randomly pad the plaintext prior to encryption. This randomizes the ciphertext so that Equation (9.2) no longer holds. However, more sophisticated CCAs are possible, and a simple padding with a random value has been shown to be insufficient to provide the desired security. To counter such attacks, RSA Security Inc., a leading RSA vendor and former holder of the RSA patent, recommends modifying the plaintext using a procedure known as **optimal asymmetric encryption padding (OAEP)**. A full discussion of the threats and OAEP are beyond our scope; see [POIN02] for an introduction and [BELL94a] for a thorough analysis. Here, we simply summarize the OAEP procedure.

Figure 9.9 depicts OAEP encryption. As a first step, the message M to be encrypted is padded. A set of optional parameters, P , is passed through a hash function, H .⁵ The output is then padded with zeros to get the desired length in the overall data block (DB). Next, a random seed is generated and passed through another hash function, called the mask generating function (MGF). The resulting hash value is bit-by-bit XORed with DB to produce a maskedDB. The maskedDB is in turn passed through the MGF to form a hash that is XORed with the seed to produce

⁵A hash function maps a variable-length data block or message into a fixed-length value called a hash code. Hash functions are discussed in depth in Chapter 11.

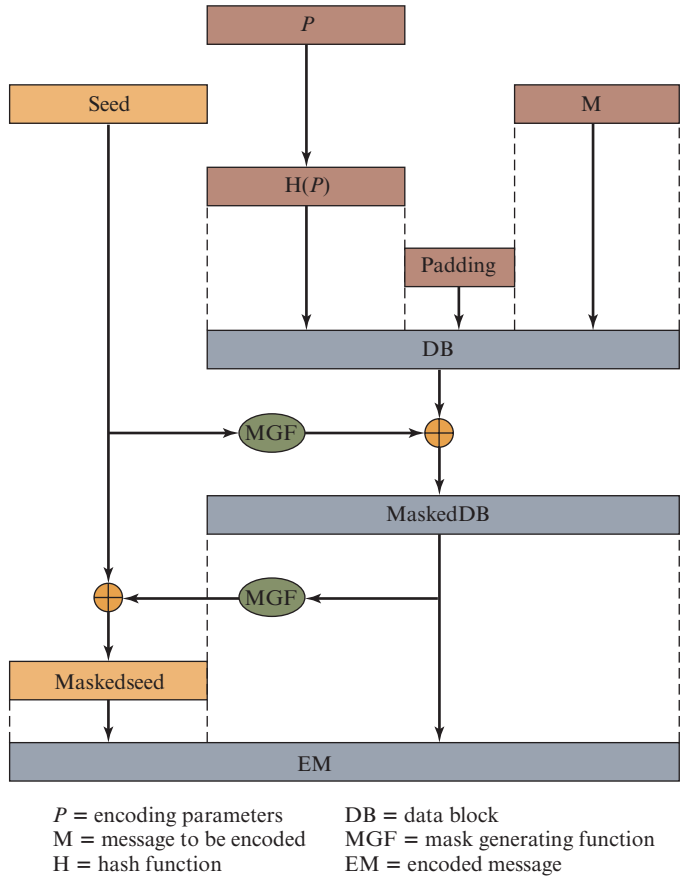

Figure 9.9 Encryption Using Optimal Asymmetric Encryption Padding (OAEP)

the maskedseed. The concatenation of the maskedseed and the maskedDB forms the encoded message EM. Note that the EM includes the padded message, masked by the seed, and the seed, masked by the maskedDB. The EM is then encrypted using RSA.

9.3 KEY TERMS, REVIEW QUESTIONS, AND PROBLEMS

Key Terms

digital signature key exchange one-way function	optimal asymmetric encryption padding (OAEP) private key public key	public-key encryption RSA secret key timing attack
---	---	---

Review Questions

- 9.1 What is a public key certificate?
- 9.2 What are the roles of the public and private key?
- 9.3 What are three broad categories of applications of public-key cryptosystems?
- 9.4 What requirements must a public-key cryptosystems fulfill to be a secure algorithm?
- 9.5 How can a probable-message attack be used for public-key cryptanalysis?
- 9.6 List the different approaches to attack the RSA algorithm.
- 9.7 Describe the countermeasures to be used against the timing attack.

Problems

9.1 Prior to the discovery of any specific public-key schemes, such as RSA, an existence proof was developed whose purpose was to demonstrate that public-key encryption is possible in theory. Consider the functions $f_1(x_1) = z_1$; $f_2(x_2, y_2) = z_2$; $f_3(x_3, y_3) = z_3$, where all values are integers with $1 \leq x_i, y_i, z_i \leq N$. Function f_1 can be represented by a vector M1 of length N , in which the k th entry is the value of $f_1(k)$. Similarly, f_2 and f_3 can be represented by $N \times N$ matrices M2 and M3. The intent is to represent the encryption/decryption process by table lookups for tables with very large values of N . Such tables would be impractically huge but could be constructed in principle. The scheme works as follows: Construct M1 with a random permutation of all integers between 1 and N ; that is, each integer appears exactly once in M1. Construct M2 so that each row contains a random permutation of the first N integers. Finally, fill in M3 to satisfy the following condition:

$$f_3(f_2(f_1(k), p), k) = p \quad \text{for all } k, p \text{ with } 1 \leq k, p \leq N$$

To summarize,

- 1. M1 takes an input k and produces an output x .
- 2. M2 takes inputs x and p giving output z .
- 3. M3 takes inputs z and k and produces p .

The three tables, once constructed, are made public.

- a. It should be clear that it is possible to construct M3 to satisfy the preceding condition. As an example, fill in M3 for the following simple case:

M1 =	4	M2 =	3	5	2	4	1	M3 =				
	3		4	2	5	3	1					
	2		5	4	3	1	2					
	5		1	3	2	5	4					
	1		2	1	4	3	5					

Convention: The i th element of M1 corresponds to $k = i$. The i th row of M2 corresponds to $x = i$; the j th column of M2 corresponds to $p = j$. The i th row of M3 corresponds to $z = i$; the j th column of M3 corresponds to $k = j$.

- b. Describe the use of this set of tables to perform encryption and decryption between two users.
 - c. Argue that this is a secure scheme.
- 9.2 Perform encryption and decryption using the RSA algorithm, as in Figure 9.5, for the following:
- a. $p = 3$; $q = 7$, $e = 5$; $M = 10$
 - b. $p = 5$; $q = 13$, $e = 5$; $M = 8$
 - c. $p = 7$; $q = 17$, $e = 11$; $M = 11$

d. $p = 7; q = 13, e = 11; M = 2$

e. $p = 17; q = 23, e = 9; M = 7$

Hint: Decryption is not as hard as you think; use some finesse.

- 9.3 In a public-key system using RSA, you intercept the ciphertext $C = 20$ sent to a user whose public key is $e = 13, n = 77$. What is the plaintext M ?
- 9.4 In an RSA system, the public key of a given user is $e = 65, n = 2881$. What is the private key of this user? *Hint:* First use trial and error to determine p and q ; then use the extended Euclidean algorithm to find the multiplicative inverse of 31 modulo $\phi(n)$.
- 9.5 In using the RSA algorithm, if a small number of repeated encodings give back the plaintext, what is the likely cause?
- 9.6 Public-key cryptography has its norms and requirements that make cryptanalysis relatively simple to understand and explain. In a scenario where party A sends a message to party B using public-key cryptography, how difficult will it be for party B to decipher the message? What is the formula to decrypt the message?
- 9.7 In RSA, the algorithm encrypts a message and transforms it into a ciphertext equal to the message itself with exponentiation modulo n or $C = M^e \bmod n$. In this case, what happens if the receiver has the value of n in advance?
- 9.8 Suppose Bob uses the RSA cryptosystem with a very large modulus n for which the factorization cannot be found in a reasonable amount of time. Suppose Alice sends a message to Bob by representing each alphabetic character as an integer between 0 and 25 ($A \rightarrow 0, \dots, Z \rightarrow 25$) and then encrypting each number separately using RSA with large e and large n . Is this method secure? If not, describe the most efficient attack against this encryption method.
- 9.9 Using a spreadsheet (such as Excel) or a calculator, perform the operations described below. Document results of all intermediate modular multiplications. Determine a number of modular multiplications per each major transformation (such as encryption, decryption, primality testing, etc.).
- Test all odd numbers in the range from 215 to 223 for primality using the Miller–Rabin test with base 2.
 - Encrypt the message block $M = 2$ using RSA with the following parameters: $e = 23$ and $n = 233 \times 241$.
 - Compute a private key (d, p, q) corresponding to the public key (e, n) given above.
 - Perform the decryption of the obtained ciphertext
 - without using the Chinese Remainder Theorem, and
 - using the Chinese Remainder Theorem.
- 9.10 The security of the RSA algorithm has been impacted due to advances in technology and the available choices of values. This can make it vulnerable to brute force attacks and timing attacks. In asymmetric algorithms, public keys are made public and private keys should be kept private. Suppose a very small public parameter, like $e = 3$, is generated to encrypt a secret message, would it affect the security of the algorithm at all?
- 9.11 “I want to tell you, Holmes,” Dr. Watson’s voice was enthusiastic, “that your recent activities in network security have increased my interest in cryptography. And just yesterday I found a way to make one-time pad encryption practical.”
- “Oh, really?” Holmes’ face lost its sleepy look.
- “Yes, Holmes. The idea is quite simple. For a given one-way function F , I generate a long pseudorandom sequence of elements by applying F to some standard sequence of arguments. The cryptanalyst is assumed to know F and the general nature of the sequence, which may be as simple as $S, S + 1, S + 2, \dots$, but not secret S . And due to the one-way nature of F , no one is able to extract S given $F(S + i)$ for some i , thus even if he somehow obtains a certain segment of the sequence, he will not be able to determine the rest.”

“I am afraid, Watson, that your proposal isn’t without flaws and at least it needs some additional conditions to be satisfied by F. Let’s consider, for instance, the RSA encryption function, that is $F(M) = M^K \bmod N$, K is secret. This function is believed to be one-way, but I wouldn’t recommend its use, for example, on the sequence $M = 2, 3, 4, 5, 6, \dots$ ”

“But why, Holmes?” Dr. Watson apparently didn’t understand. “Why do you think that the resulting sequence $2^K \bmod N, 3^K \bmod N, 4^K \bmod N, \dots$ is not appropriate for one-time pad encryption if K is kept secret?”

“Because it is—at least partially—predictable, dear Watson, even if K is kept secret. You have said that the cryptanalyst is assumed to know F and the general nature of the sequence. Now let’s assume that he will obtain somehow a short segment of the output sequence. In crypto circles, this assumption is generally considered to be a viable one. And for this output sequence, knowledge of just the first two elements will allow him to predict quite a lot of the next elements of the sequence, even if not all of them, thus this sequence can’t be considered to be cryptographically strong. And with the knowledge of a longer segment he could predict even more of the next elements of the sequence. Look, knowing the general nature of the sequence and its first two elements $2^K \bmod N$ and $3^K \bmod N$, you can easily compute its following elements.”

Show how this can be done.

- 9.12** Show how RSA can be represented by matrices M_1, M_2 , and M_3 of Problem 9.1.
- 9.13** To understand the initial steps of RSA calculations for generating the public key, consider the following scheme to determine $PU = \{e, n\}$. Suppose you have two prime numbers p and q , where $p = 20$ and $q = 14$.

- Calculate $n = pq$
- Calculate $\phi(n) = (p - 1)(q - 1)$
- Select a value of e such that it is relatively prime to $\phi(n)$.

What needs to be determined to complete the key generation process? Show your calculations based on your answers to parts **a** to **c**.

- 9.14** Consider the following scheme by which B encrypts a message for A.
- A chooses two large primes P and Q that are also relatively prime to $(P - 1)$ and $(Q - 1)$.
 - A publishes $N = PQ$ as its public key.
 - A calculates P' and Q' such that $PP' \equiv 1 \pmod{Q - 1}$ and $QQ' \equiv 1 \pmod{P - 1}$.
 - B encrypts message M as $C = M^N \bmod N$.
 - A finds M by solving $M \equiv C^{P'} \pmod{Q}$ and $M \equiv C^{Q'} \pmod{P}$.
 - Explain how this scheme works.
 - How does it differ from RSA?
 - Is there any particular advantage to RSA compared to this scheme?
 - Show how this scheme can be represented by matrices M_1, M_2 , and M_3 of Problem 9.1.

- 9.15** “This is a very interesting case, Watson,” Holmes said. “The young man loves a girl, and she loves him too. However, her father is a strange fellow who insists that his would-be son-in-law must design a simple and secure protocol for an appropriate public-key cryptosystem he could use in his company’s computer network. The young man came up with the following protocol for communication between two parties. For example, user A wishing to send message M to user B: (messages exchanged are in the format sender’s name, text, receiver’s name)”

- A sends B the following block: $(A, E(PU_b, [M, A]), B)$.
- B acknowledges receipt by sending to A the following block: $(B, E(PU_a, [M, B]), A)$.

“You can see that the protocol is really simple. But the girl’s father claims that the young man has not satisfied his call for a simple protocol, because the proposal contains a certain redundancy and can be further simplified to the following:”

1. A sends B the block: $(A, E(PU_b, M), B)$.
2. B acknowledges receipt by sending to A the block: $(B, E(PU_a, M), A)$.

“On the basis of that, the girl’s father refuses to allow his daughter to marry the young man, thus making them both unhappy. The young man was just here to ask me for help.”

“Hmm, I don’t see how you can help him.” Watson was visibly unhappy with the idea that the sympathetic young man has to lose his love.

“Well, I think I could help. You know, Watson, redundancy is sometimes good to ensure the security of protocol. Thus, the simplification the girl’s father has proposed could make the new protocol vulnerable to an attack the original protocol was able to resist,” mused Holmes. “Yes, it is so, Watson. Look, all an adversary needs is to be one of the users of the network and to be able to intercept messages exchanged between A and B. Being a user of the network, he has his own public encryption key and is able to send his own messages to A or to B and to receive theirs. With the help of the simplified protocol, he could then obtain message M user A has previously sent to B using the following procedure:”

Complete the description.

- 9.16 Use the fast exponentiation algorithm of Figure 9.8 to determine $6^{472} \bmod 3415$. Show the steps involved in the computation.
- 9.17 Here is another realization of the fast exponentiation algorithm. Demonstrate that it is equivalent to the one in Figure 9.8.
1. $f \leftarrow 1$; $T \leftarrow a$; $E \leftarrow b$
 2. **if** odd(E) **then** $f \leftarrow f \times T$
 3. $E \leftarrow \lfloor E/2 \rfloor$
 4. $T \leftarrow T \times T$
 5. **if** $E > 0$ **then goto** 2
 6. **output** f

- 9.18 This problem illustrates a simple application of the chosen ciphertext attack. Bob intercepts a ciphertext C intended for Alice and encrypted with Alice’s public key e . Bob wants to obtain the original message $M = C^d \bmod n$. Bob chooses a random value r less than n and computes

$$Z = r^e \bmod n$$

$$X = ZC \bmod n$$

$$t = r^{-1} \bmod n$$

Next, Bob gets Alice to authenticate (sign) X with her private key (as in Figure 9.3), thereby decrypting X . Alice returns $Y = X^d \bmod n$. Show how Bob can use the information now available to him to determine M .

- 9.19 Show the OAEP decoding operation used for decryption that corresponds to the encoding operation of Figure 9.9.

CHAPTER 10

OTHER PUBLIC-KEY CRYPTOSYSTEMS

10.1 Diffie–Hellman Key Exchange

- The Algorithm
- Key Exchange Protocols
- Man-in-the-Middle Attack

10.2 ElGamal Cryptographic System

10.3 Elliptic Curve Arithmetic

- Abelian Groups
- Elliptic Curves over Real Numbers
- Elliptic Curves over \mathbb{Z}_p
- Elliptic Curves over $\text{GF}(2^m)$

10.4 Elliptic Curve Cryptography

- Analog of Diffie–Hellman Key Exchange
- Elliptic Curve Encryption/Decryption
- Security of Elliptic Curve Cryptography

10.5 Key Terms, Review Questions, and Problems

LEARNING OBJECTIVES

After studying this chapter, you should be able to:

- ◆ Define Diffie–Hellman key exchange.
- ◆ Understand the man-in-the-middle attack.
- ◆ Present an overview of the ElGamal cryptographic system.
- ◆ Understand elliptic curve arithmetic.
- ◆ Present an overview of elliptic curve cryptography.
- ◆ Present two techniques for generating pseudorandom numbers using an asymmetric cipher.

This chapter begins with a description of one of the earliest and simplest PKCS: Diffie–Hellman key exchange. The chapter then looks at another important scheme, the ElGamal PKCS. Next, we look at the increasingly important PKCS known as elliptic curve cryptography.

10.1 DIFFIE–HELLMAN KEY EXCHANGE

The first published public-key algorithm appeared in the seminal paper by Diffie and Hellman that defined public-key cryptography [DIFF76b] and is generally referred to as Diffie–Hellman key exchange. A number of commercial products employ this key exchange technique.

The purpose of the algorithm is to enable two users to securely exchange a key that can then be used for subsequent symmetric encryption of messages. The algorithm itself is limited to the exchange of secret values.

The Diffie–Hellman algorithm depends for its effectiveness on the difficulty of computing discrete logarithms. Briefly, we can define the discrete logarithm in the following way. Recall from Chapter 2 that a **primitive root** of a prime number p is one whose powers modulo p generate all the integers from 1 to $p - 1$. That is, if a is a primitive root of the prime number p , then the numbers

$$a \bmod p, a^2 \bmod p, \dots, a^{p-1} \bmod p$$

are distinct and consist of the integers from 1 through $p - 1$ in some permutation.

For any integer b and a primitive root a of prime number p , we can find a unique exponent i such that

$$b \equiv a^i \pmod{p} \quad \text{where } 0 \leq i \leq (p - 1)$$

The exponent i is referred to as the **discrete logarithm** of b for the base a , mod p . We express this value as $\text{dlog}_{a,p}(b)$. See Chapter 2 for an extended discussion of discrete logarithms.

The Algorithm

Figure 10.1 summarizes the Diffie–Hellman key exchange algorithm. For this scheme, there are two publicly known numbers: a prime number q and an integer α that is a primitive root of q . Suppose the users Alice and Bob wish to create a shared key.

Alice selects a random integer $X_A < q$ and computes $Y_A = \alpha^{X_A} \bmod q$. Similarly, Bob independently selects a random integer $X_B < q$ and computes $Y_B = \alpha^{X_B} \bmod q$. Each side keeps the X value private and makes the Y value available publicly to the other side. Thus, X_A is Alice’s private key and Y_A is Alice’s corresponding public key, and similarly for Bob. Alice computes the key as $K = (Y_B)^{X_A} \bmod q$ and Bob computes the key as $K = (Y_A)^{X_B} \bmod q$. These two calculations produce identical results:

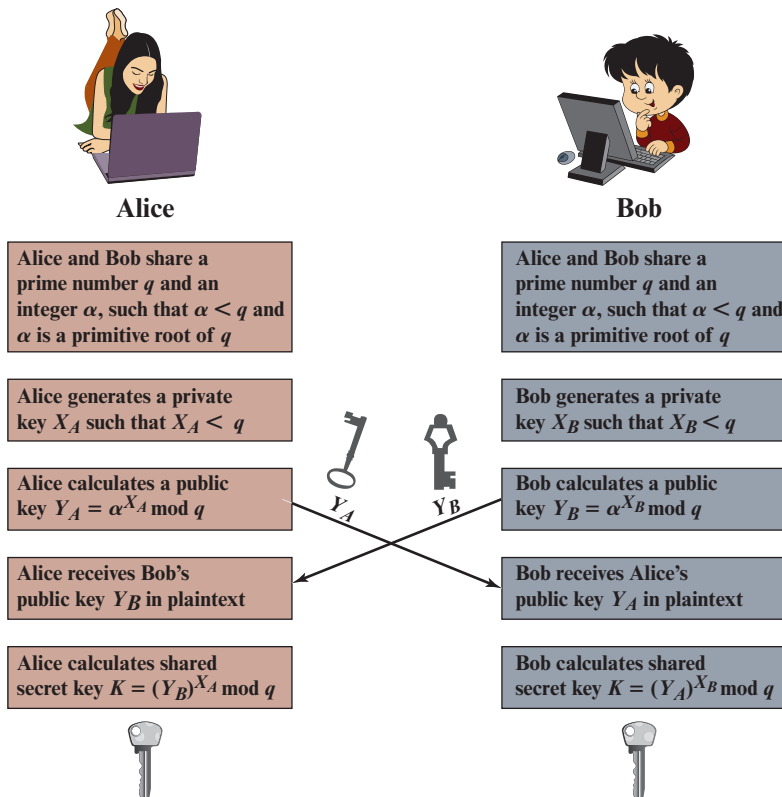

Figure 10.1 The Diffie–Hellman Key Exchange

$$\begin{aligned}
K &= (Y_B)^{X_A} \bmod q \\
&= (\alpha^{X_B} \bmod q)^{X_A} \bmod q \\
&= (\alpha^{X_B})^{X_A} \bmod q && \text{by the rules of modular arithmetic} \\
&= \alpha^{X_B X_A} \bmod q \\
&= (\alpha^{X_A})^{X_B} \bmod q \\
&= (\alpha^{X_A} \bmod q)^{X_B} \bmod q \\
&= (Y_A)^{X_B} \bmod q
\end{aligned}$$

The result is that the two sides have exchanged a secret value. Typically, this secret value is used as shared symmetric secret key. Now consider an adversary who can observe the key exchange and wishes to determine the secret key K . Because X_A and X_B are private, an adversary only has the following ingredients to work with: q , α , Y_A , and Y_B . Thus, the adversary is forced to take a discrete logarithm to determine the key. For example, to determine Bob's private key, an adversary must compute

$$X_B = \text{dlog}_{\alpha, q}(Y_B)$$

The adversary can then calculate the key K in the same manner as Bob calculates it. That is, the adversary can calculate K as

$$K = (Y_A)^{X_B} \bmod q$$

The security of the Diffie–Hellman key exchange lies in the fact that, while it is relatively easy to calculate exponentials modulo a prime, it is very difficult to calculate discrete logarithms. For large primes, the latter task is considered infeasible.

Here is an example. Key exchange is based on the use of the prime number $q = 353$ and a primitive root of 353, in this case $\alpha = 3$. Alice and Bob select private keys $X_A = 97$ and $X_B = 233$, respectively. Each computes its public key:

$$\text{Alice computes } Y_A = 3^{97} \bmod 353 = 40.$$

$$\text{Bob computes } Y_B = 3^{233} \bmod 353 = 248.$$

After they exchange public keys, each can compute the common secret key:

$$\text{Alice computes } K = (Y_B)^{X_A} \bmod 353 = 248^{97} \bmod 353 = 160.$$

$$\text{Bob computes } K = (Y_A)^{X_B} \bmod 353 = 40^{233} \bmod 353 = 160.$$

We assume an attacker would have available the following information:

$$q = 353; \alpha = 3; Y_A = 40; Y_B = 248$$

In this simple example, it would be possible by brute force to determine the secret key 160. In particular, an attacker E can determine the common key by discovering a solution to the equation $3^a \bmod 353 = 40$ or the equation $3^b \bmod 353 = 248$. The brute-force approach is to calculate powers of 3 modulo 353, stopping when the result equals either 40 or 248. The desired answer is reached with the exponent value of 97, which provides $3^{97} \bmod 353 = 40$.

With larger numbers, the problem becomes impractical.

Key Exchange Protocols

Figure 10.1 shows a simple protocol that makes use of the Diffie–Hellman calculation. Suppose that user A wishes to set up a connection with user B and use a secret key to encrypt messages on that connection. User A can generate a one-time private key X_A , calculate Y_A , and send that to user B. User B responds by generating a private value X_B , calculating Y_B , and sending Y_B to user A. Both users can now calculate the key. The necessary public values q and α would need to be known ahead of time. Alternatively, user A could pick values for q and α and include those in the first message.

As an example of another use of the Diffie–Hellman algorithm, suppose that a group of users (e.g., all users on a LAN) each generate a long-lasting private value X_i (for user i) and calculate a public value Y_i . These public values, together with global public values for q and α , are stored in some central directory. At any time, user j can access user i 's public value, calculate a secret key, and use that to send an encrypted message to user A. If the central directory is trusted, then this form of communication provides both confidentiality and a degree of authentication. Because only i and j can determine the key, no other user can read the message (confidentiality). Recipient i knows that only user j could have created a message using this key (authentication). However, the technique does not protect against replay attacks.

Man-in-the-Middle Attack

The protocol depicted in Figure 10.1 is insecure against a **man-in-the-middle attack**. Suppose Alice and Bob wish to exchange keys, and Darth is the adversary. The attack proceeds as follows (Figure 10.2).

1. Darth prepares for the attack by generating two random private keys X_{D1} and X_{D2} and then computing the corresponding public keys Y_{D1} and Y_{D2} .
2. Alice transmits Y_A to Bob.
3. Darth intercepts Y_A and transmits Y_{D1} to Bob. Darth also calculates $K2 = (Y_A)^{X_{D2}} \bmod q$.
4. Bob receives Y_{D1} and calculates $K1 = (Y_{D1})^{X_B} \bmod q$.
5. Bob transmits Y_B to Alice.
6. Darth intercepts Y_B and transmits Y_{D2} to Alice. Darth calculates $K1 = (Y_B)^{X_{D1}} \bmod q$.
7. Alice receives Y_{D2} and calculates $K2 = (Y_{D2})^{X_A} \bmod q$.

At this point, Bob and Alice think that they share a secret key, but instead Bob and Darth share secret key $K1$ and Alice and Darth share secret key $K2$. All future communication between Bob and Alice is compromised in the following way.

1. Alice sends an encrypted message M : $E(K2, M)$.
2. Darth intercepts the encrypted message and decrypts it to recover M .
3. Darth sends Bob $E(K1, M)$ or $E(K1, M')$, where M' is any message. In the first case, Darth simply wants to eavesdrop on the communication without altering it. In the second case, Darth wants to modify the message going to Bob.

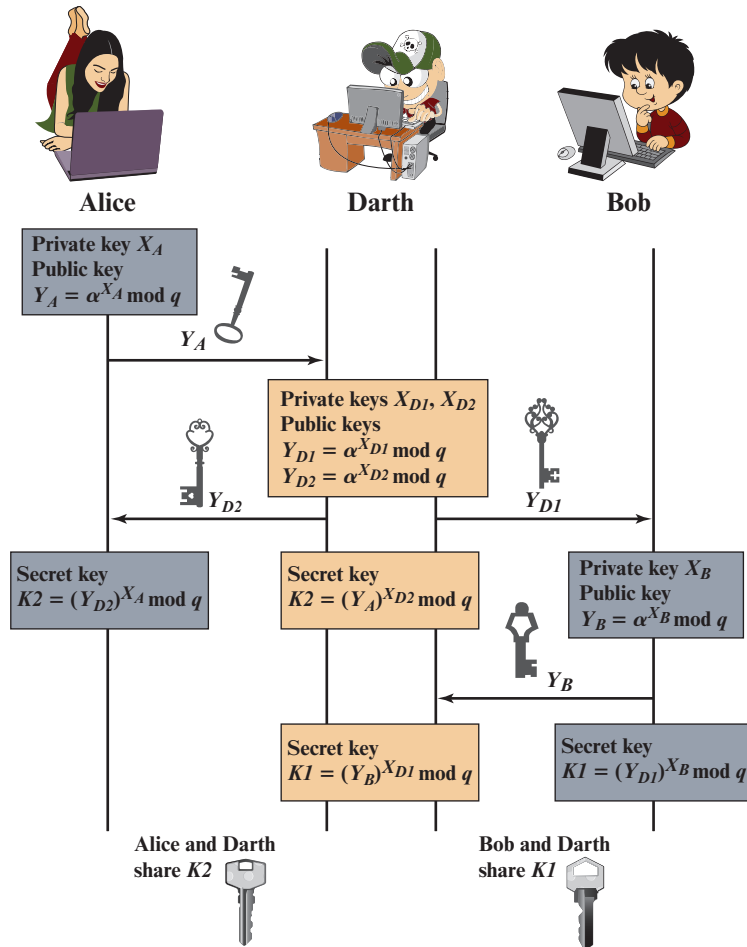

Figure 10.2 Man-in-the-Middle Attack

The key exchange protocol is vulnerable to such an attack because it does not authenticate the participants. This vulnerability can be overcome with the use of digital signatures and public-key certificates; these topics are explored in Chapters 13 and 14.

10.2 ELGAMAL CRYPTOGRAPHIC SYSTEM

In 1984, T. ElGamal announced a public-key scheme based on discrete logarithms, closely related to the Diffie–Hellman technique [ELGA84, ELGA85]. The ElGamal cryptosystem is used in some form in a number of standards including the digital signature standard (DSS), which is covered in Chapter 13, and the S/MIME email standard (Chapter 21).

As with Diffie–Hellman, the global elements of ElGamal are a prime number q and α , which is a primitive root of q . User A generates a private/public key pair as follows:

1. Generate a random integer X_A , such that $1 < X_A < q - 1$.
2. Compute $Y_A = \alpha^{X_A} \bmod q$.
3. A's private key is X_A and A's public key is $\{q, \alpha, Y_A\}$.

Any user B that has access to A's public key can encrypt a message as follows:

1. Represent the message as an integer M in the range $0 \leq M \leq q - 1$. Longer messages are sent as a sequence of blocks, with each block being an integer less than q .
2. Choose a random integer k such that $1 \leq k \leq q - 1$.
3. Compute a one-time key $K = (Y_A)^k \bmod q$.
4. Encrypt M as the pair of integers (C_1, C_2) where

$$C_1 = \alpha^k \bmod q; C_2 = KM \bmod q$$

User A recovers the plaintext as follows:

1. Recover the key by computing $K = (C_1)^{X_A} \bmod q$.
2. Compute $M = (C_2 K^{-1}) \bmod q$.

These steps are summarized in Figure 10.3. It corresponds to Figure 9.1a: Alice generates a public/private key pair; Bob encrypts using Alice's public key; and Alice decrypts using her private key.

Let us demonstrate why the ElGamal scheme works. First, we show how K is recovered by the decryption process:

$K = (Y_A)^k \bmod q$	K is defined during the encryption process
$K = (\alpha^{X_A} \bmod q)^k \bmod q$	substitute using $Y_A = \alpha^{X_A} \bmod q$
$K = \alpha^{kX_A} \bmod q$	by the rules of modular arithmetic
$K = (C_1)^{X_A} \bmod q$	substitute using $C_1 = \alpha^k \bmod q$

Next, using K , we recover the plaintext as

$$C_2 = KM \bmod q$$

$$(C_2 K^{-1}) \bmod q = KMK^{-1} \bmod q = M \bmod q = M$$

We can restate the ElGamal process as follows, using Figure 10.3.

1. Bob generates a random integer k .
2. Bob generates a one-time key K using Alice's public-key components Y_A , q , and k .
3. Bob encrypts k using the public-key component α , yielding C_1 . C_1 provides sufficient information for Alice to recover K .
4. Bob encrypts the plaintext message M using K .
5. Alice recovers K from C_1 using her private key.
6. Alice uses K^{-1} to recover the plaintext message from C_2 .

Global Public Elements	
q	prime number
α	$\alpha < q$ and α a primitive root of q

Key Generation by Alice	
Select private X_A	$X_A < q - 1$
Calculate Y_A	$Y_A = \alpha^{X_A} \bmod q$
Public key	$\{q, \alpha, Y_A\}$
Private key	X_A

Encryption by Bob with Alice's Public Key	
Plaintext:	$M < q$
Select random integer k	$k < q$
Calculate K	$K = (Y_A)^k \bmod q$
Calculate C_1	$C_1 = \alpha^k \bmod q$
Calculate C_2	$C_2 = KM \bmod q$
Ciphertext:	(C_1, C_2)

Decryption by Alice with Alice's Private Key	
Ciphertext:	(C_1, C_2)
Calculate K	$K = (C_1)^{X_A} \bmod q$
Plaintext:	$M = (C_2 K^{-1}) \bmod q$

Figure 10.3 The ElGamal Cryptosystem

Thus, K functions as a one-time key, used to encrypt and decrypt the message.

For example, let us start with the prime field $\text{GF}(19)$; that is, $q = 19$. It has primitive roots $\{2, 3, 10, 13, 14, 15\}$, as shown in Table 2.7. We choose $\alpha = 10$.

Alice generates a key pair as follows:

1. Alice chooses $X_A = 5$.
2. Then $Y_A = \alpha^{X_A} \bmod q = 10^5 \bmod 19 = 3$ (see Table 2.7).
3. Alice's private key is 5 and Alice's public key is $\{q, \alpha, Y_A\} = \{19, 10, 3\}$.

Suppose Bob wants to send the message with the value $M = 17$. Then:

1. Bob chooses $k = 6$.
2. Then $K = (Y_A)^k \bmod q = 3^6 \bmod 19 = 729 \bmod 19 = 7$.
3. So

$$C_1 = \alpha^k \bmod q = \alpha^6 \bmod 19 = 11$$

$$C_2 = KM \bmod q = 7 \times 17 \bmod 19 = 119 \bmod 19 = 5$$
4. Bob sends the ciphertext $(11, 5)$.

For decryption:

1. Alice calculates $K = (C_1)^{X_A} \bmod q = 11^5 \bmod 19 = 161051 \bmod 19 = 7$.
2. Then K^{-1} in $\text{GF}(19)$ is $7^{-1} \bmod 19 = 11$.
3. Finally, $M = (C_2 K^{-1}) \bmod q = 5 \times 11 \bmod 19 = 55 \bmod 19 = 17$.

If a message must be broken up into blocks and sent as a sequence of encrypted blocks, a unique value of k should be used for each block. If k is used for more than one block, knowledge of one block M_1 of the message enables the user to compute other blocks as follows. Let

$$C_{1,1} = \alpha^k \bmod q; C_{2,1} = KM_1 \bmod q$$

$$C_{1,2} = \alpha^k \bmod q; C_{2,2} = KM_2 \bmod q$$

Then,

$$\frac{C_{2,1}}{C_{2,2}} = \frac{KM_1 \bmod q}{KM_2 \bmod q} = \frac{M_1 \bmod q}{M_2 \bmod q}$$

If M_1 is known, then M_2 is easily computed as

$$M_2 = (C_{2,1})^{-1} C_{2,2} M_1 \bmod q$$

The security of ElGamal is based on the difficulty of computing discrete logarithms. To recover A 's private key, an adversary would have to compute $X_A = \text{dlog}_{\alpha,q}(Y_A)$. Alternatively, to recover the one-time key K , an adversary would have to determine the random number k , and this would require computing the discrete logarithm $k = \text{dlog}_{\alpha,q}(C_1)$. [STIN06] points out that these calculations are regarded as infeasible if p is at least 300 decimal digits and $q - 1$ has at least one "large" prime factor.

10.3 ELLIPTIC CURVE ARITHMETIC

Most of the products and standards that use public-key cryptography for encryption and digital signatures use RSA. As we have seen, the key length for secure RSA use has increased over recent years, and this has put a heavier processing load on applications using RSA. This burden has ramifications, especially for electronic commerce sites that conduct large numbers of secure transactions. A competing system challenges RSA: elliptic curve cryptography (ECC). ECC is showing up in standardization efforts, including the IEEE P1363 Standard for Public-Key Cryptography.

The principal attraction of ECC, compared to RSA, is that it appears to offer equal security for a far smaller key size, thereby reducing processing overhead.

ECC is fundamentally more difficult to explain than either RSA or Diffie–Hellman, and a full mathematical description is beyond the scope of this book. This section and the next give some background on elliptic curves and ECC. We begin with a brief review of the concept of abelian group. Next, we examine the concept of elliptic curves defined over the real numbers. This is followed by a look at elliptic curves defined over finite fields. Finally, we are able to examine elliptic curve ciphers.

The reader may wish to review the material on finite fields in Chapter 5 before proceeding.

Abelian Groups

Recall from Chapter 5 that an abelian group G , sometimes denoted by $\{G, \cdot\}$, is a set of elements with a binary operation, denoted by \cdot , that associates to each ordered pair (a, b) of elements in G an element $(a \cdot b)$ in G , such that the following axioms are obeyed:¹

- (A1) Closure:** If a and b belong to G , then $a \cdot b$ is also in G .
- (A2) Associative:** $a \cdot (b \cdot c) = (a \cdot b) \cdot c$ for all a, b, c in G .
- (A3) Identity element:** There is an element e in G such that $a \cdot e = e \cdot a = a$ for all a in G .
- (A4) Inverse element:** For each a in G there is an element a' in G such that $a \cdot a' = a' \cdot a = e$.
- (A5) Commutative:** $a \cdot b = b \cdot a$ for all a, b in G .

A number of public-key ciphers are based on the use of an abelian group. For example, Diffie–Hellman key exchange involves multiplying pairs of nonzero integers modulo a prime number q . Keys are generated by exponentiation over the group, with exponentiation defined as repeated multiplication. For example, $a^k \bmod q = \underbrace{(a \times a \times \dots \times a)}_{k \text{ times}} \bmod q$. To attack Diffie–Hellman, the attacker must

determine k given a and a^k ; this is the discrete logarithm problem.

For elliptic curve cryptography, an operation over elliptic curves, called addition, is used. Multiplication is defined by repeated addition. For example,

$$a \times k = \underbrace{(a + a + \dots + a)}_{k \text{ times}}$$

where the addition is performed over an elliptic curve. Cryptanalysis involves determining k given a and $(a \times k)$.

¹The operator \cdot is generic and can refer to addition, multiplication, or some other mathematical operation.

An **elliptic curve** is defined by an equation in two variables with coefficients. For cryptography, the variables and coefficients are restricted to elements in a finite field, which results in the definition of a finite abelian group. Before looking at this, we first look at elliptic curves in which the variables and coefficients are real numbers. This case is perhaps easier to visualize.

Elliptic Curves over Real Numbers

Elliptic curves are not ellipses. They are so named because they are described by cubic equations, similar to those used for calculating the circumference of an ellipse. In general, cubic equations for elliptic curves take the following form, known as a **Weierstrass equation**:

$$y^2 + axy + by = x^3 + cx^2 + dx + e$$

where a, b, c, d, e are real numbers and x and y take on values in the real numbers.² For our purpose, it is sufficient to limit ourselves to equations of the form

$$y^2 = x^3 + ax + b \tag{10.1}$$

Such equations are said to be cubic, or of degree 3, because the highest exponent they contain is a 3. Also included in the definition of an elliptic curve is a single element denoted O and called the *point at infinity* or the zero point, which we discuss subsequently. To plot such a curve, we need to compute

$$y = \sqrt{x^3 + ax + b}$$

For given values of a and b , the plot consists of positive and negative values of y for each value of x . Thus, each curve is symmetric about $y = 0$. Figure 10.4 shows two examples of elliptic curves. As you can see, the formula sometimes produces weird-looking curves.

Now, consider the set of points $E(a, b)$ consisting of all of the points (x, y) that satisfy Equation (10.1) together with the element O . Using a different value of the pair (a, b) results in a different set $E(a, b)$. Using this terminology, the two curves in Figure 10.4 depict the sets $E(-1, 0)$ and $E(1, 1)$, respectively.

GEOMETRIC DESCRIPTION OF ADDITION It can be shown that a group can be defined based on the set $E(a, b)$ for specific values of a and b in Equation (10.1), provided the following condition is met:

$$4a^3 + 27b^2 \neq 0 \tag{10.2}$$

To define the group, we must define an operation, called addition and denoted by $+$, for the set $E(a, b)$, where a and b satisfy Equation (10.2). In geometric terms, the rules for addition can be stated as follows: If three points on an elliptic curve lie on a straight line, their sum is O . From this definition, we can define the rules of addition over an elliptic curve.

²Note that x and y are true variables, which take on values. This is in contrast to our discussion of polynomial rings and fields in Chapter 5, where was treated as an indeterminate.

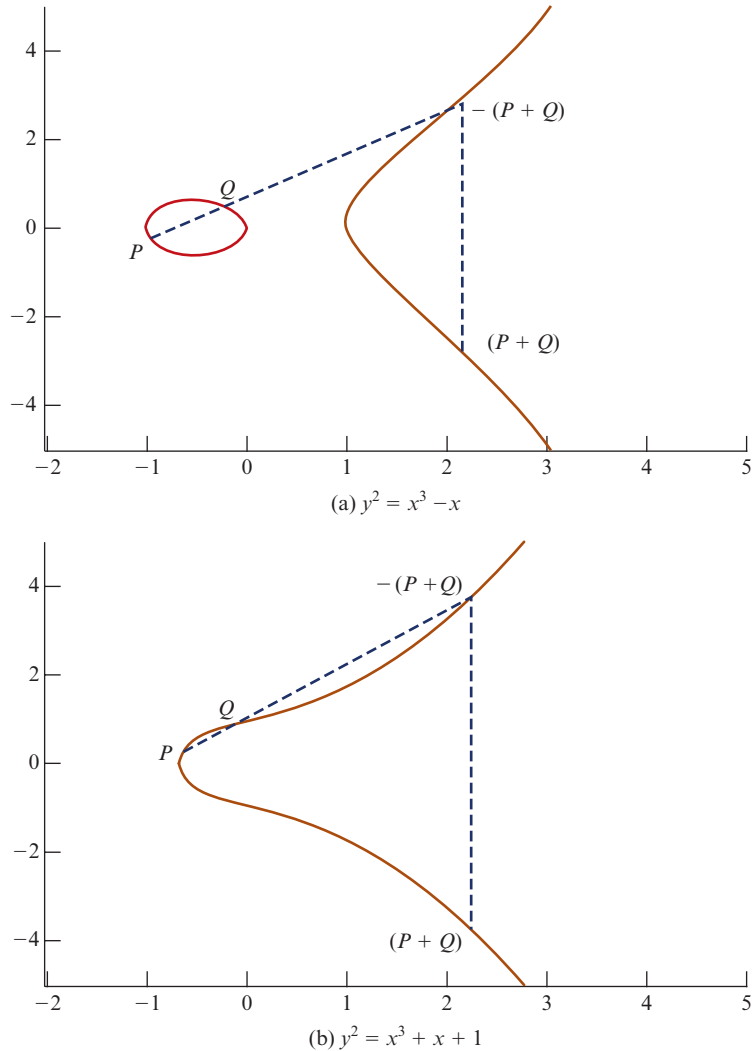

Figure 10.4 Example of Elliptic Curves

1. O serves as the additive identity. Thus $O = -O$; for any point P on the elliptic curve, $P + O = P$. In what follows, we assume $P \neq O$ and $Q \neq O$.
2. The negative of a point P is the point with the same x coordinate but the negative of the y coordinate; that is, if $P = (x, y)$, then $-P = (x, -y)$. Note that these two points can be joined by a vertical line. Note that $P + (-P) = P - P = O$.
3. To add two points P and Q with different x coordinates, draw a straight line between them and find the third point of intersection R . It is easily seen that there is a unique point R that is the point of intersection (unless the line is tangent to the curve at either P or Q , in which case we take $R = P$ or $R = Q$, respectively). To form a group structure, we need to define addition on these three points: $P + Q = -R$. That is, we define $P + Q$ to be the mirror image

(with respect to the x axis) of the third point of intersection. Figure 10.4 illustrates this construction.

4. The geometric interpretation of the preceding item also applies to two points, P and $-P$, with the same x coordinate. The points are joined by a vertical line, which can be viewed as also intersecting the curve at the infinity point. We therefore have $P + (-P) = O$, which is consistent with item (2).
5. To double a point Q , draw the tangent line and find the other point of intersection S . Then $Q + Q = 2Q = -S$.

With the preceding list of rules, it can be shown that the set $E(a, b)$ is an abelian group.

ALGEBRAIC DESCRIPTION OF ADDITION In this subsection, we present some results that enable calculation of additions over elliptic curves.³ For two distinct points, $P = (x_P, y_P)$ and $Q = (x_Q, y_Q)$, that are not negatives of each other, the slope of the line l that joins them is $\Delta = (y_Q - y_P)/(x_Q - x_P)$. There is exactly one other point where l intersects the elliptic curve, and that is the negative of the sum of P and Q . After some algebraic manipulation, we can express the sum $R = P + Q$ as

$$\begin{aligned}x_R &= \Delta^2 - x_P - x_Q \\y_R &= -y_P + \Delta(x_P - x_R)\end{aligned}\tag{10.3}$$

We also need to be able to add a point to itself: $P + P = 2P = R$. When $y_P \neq 0$, the expressions are

$$\begin{aligned}x_R &= \left(\frac{3x_P^2 + a}{2y_P}\right)^2 - 2x_P \\y_R &= \left(\frac{3x_P^2 + a}{2y_P}\right)(x_P - x_R) - y_P\end{aligned}\tag{10.4}$$

Elliptic Curves over Z_p

Elliptic curve cryptography makes use of elliptic curves in which the variables and coefficients are all restricted to elements of a finite field. Two families of elliptic curves are used in cryptographic applications: prime curves over Z_p and binary curves over $\text{GF}(2^m)$. For a prime curve over Z_p , we use a cubic equation in which the variables and coefficients all take on values in the set of integers from 0 through $p - 1$ and in which calculations are performed modulo p . For a binary curve defined over $\text{GF}(2^m)$, the variables and coefficients all take on values in $\text{GF}(2^m)$ and in calculations are performed over $\text{GF}(2^m)$. [FERN99] points out that prime curves are best for software applications, because the extended bit-fiddling operations needed by binary curves are not required; and that binary curves are best for hardware applications, where it takes remarkably few logic gates to create a powerful, fast cryptosystem. We examine these two families in this section and the next.

³For derivations of these results, see [KOB94] or other mathematical treatments of elliptic curves.

There is no obvious geometric interpretation of elliptic curve arithmetic over finite fields. The algebraic interpretation used for elliptic curve arithmetic over real numbers does readily carry over, and this is the approach we take.

For elliptic curves over \mathbb{Z}_p , as with real numbers, we limit ourselves to equations of the form of Equation (10.1), but in this case with coefficients and variables limited to \mathbb{Z}_p :

$$y^2 \bmod p = (x^3 + ax + b) \bmod p \tag{10.5}$$

For example, Equation (10.5) is satisfied for $a = 1, b = 1, x = 9, y = 7, p = 23$:

$$\begin{aligned} 7^2 \bmod 23 &= (9^3 + 9 + 1) \bmod 23 \\ 49 \bmod 23 &= 739 \bmod 23 \\ 3 &= 3 \end{aligned}$$

Now consider the set $E_p(a, b)$ consisting of all pairs of integers (x, y) that satisfy Equation (10.5), together with a point at infinity O . The coefficients a and b and the variables x and y are all elements of \mathbb{Z}_p .

For example, let $p = 23$ and consider the elliptic curve $y^2 = x^3 + x + 1$. In this case, $a = b = 1$. Note that this equation is the same as that of Figure 10.4b. The figure shows a continuous curve with all of the real points that satisfy the equation. For the set $E_{23}(1, 1)$, we are only interested in the nonnegative integers in the quadrant from $(0, 0)$ through $(p - 1, p - 1)$ that satisfy the equation mod p . Table 10.1 lists the points (other than O) that are part of $E_{23}(1, 1)$. Figure 10.5 plots the points of $E_{23}(1, 1)$; note that the points, with one exception, are symmetric about $y = 11.5$.

It can be shown that a finite abelian group can be defined based on the set $E_p(a, b)$ provided that $(x^3 + ax + b) \bmod p$ has no repeated factors. This is equivalent to the condition

$$(4a^3 + 27b^2) \bmod p \neq 0 \bmod p \tag{10.6}$$

Note that Equation (10.6) has the same form as Equation (10.2).

The rules for addition over $E_p(a, b)$, correspond to the algebraic technique described for elliptic curves defined over real numbers. For all points $P, Q \in E_p(a, b)$:

Table 10.1 Points (other than O) on the Elliptic Curve $E_{23}(1, 1)$

(0, 1)	(6, 4)	(12, 19)
(0, 22)	(6, 19)	(13, 7)
(1, 7)	(7, 11)	(13, 16)
(1, 16)	(7, 12)	(17, 3)
(3, 10)	(9, 7)	(17, 20)
(3, 13)	(9, 16)	(18, 3)
(4, 0)	(11, 3)	(18, 20)
(5, 4)	(11, 20)	(19, 5)
(5, 19)	(12, 4)	(19, 18)

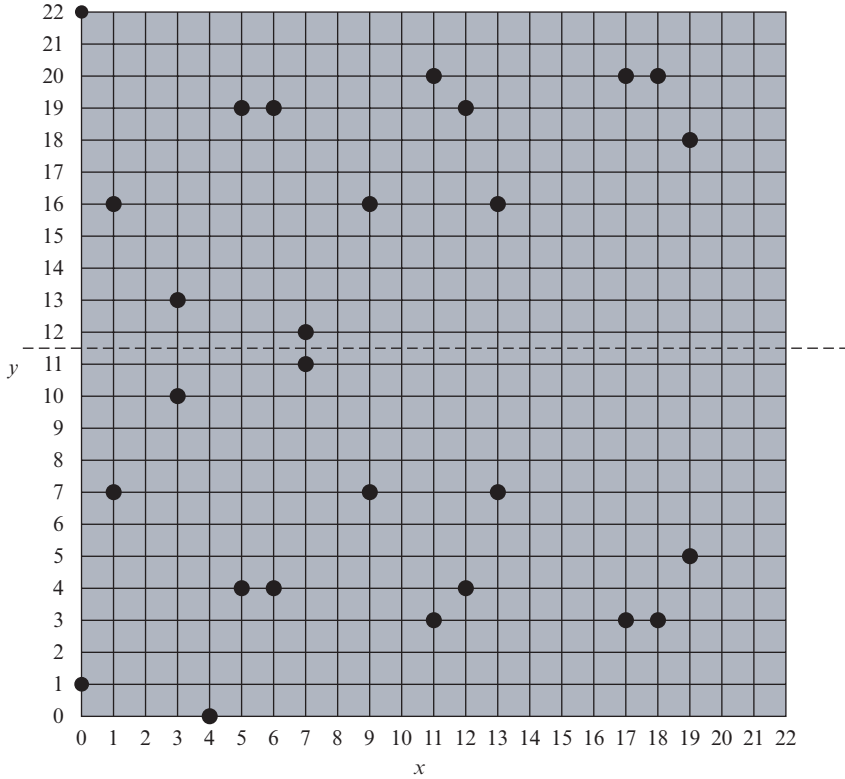

Figure 10.5 The Elliptic Curve $E_{23}(1, 1)$

1. $P + O = P$.
2. If $P = (x_P, y_P)$, then $P + (x_P, -y_P) = O$. The point $(x_P, -y_P)$ is the negative of P , denoted as $-P$. For example, in $E_{23}(1, 1)$, for $P = (13, 7)$, we have $-P = (13, -7)$. But $-7 \bmod 23 = 16$. Therefore, $-P = (13, 16)$, which is also in $E_{23}(1, 1)$.
3. If $P = (x_P, y_P)$ and $Q = (x_Q, y_Q)$ with $P \neq -Q$, then $R = P + Q = (x_R, y_R)$ is determined by the following rules:

$$\begin{aligned} x_R &= (\lambda^2 - x_P - x_Q) \bmod p \\ y_R &= (\lambda(x_P - x_R) - y_P) \bmod p \end{aligned}$$

where

$$\lambda = \begin{cases} \left(\frac{y_Q - y_P}{x_Q - x_P} \right) \bmod p & \text{if } P \neq Q \\ \left(\frac{3x_P^2 + a}{2y_P} \right) \bmod p & \text{if } P = Q \end{cases}$$

4. Multiplication is defined as repeated addition; for example, $4P = P + P + P + P$.

For example, let $P = (3, 10)$ and $Q = (9, 7)$ in $E_{23}(1, 1)$. Then

$$\lambda = \left(\frac{7 - 10}{9 - 3} \right) \bmod 23 = \left(\frac{-3}{6} \right) \bmod 23 = \left(\frac{-1}{2} \right) \bmod 23 = 11$$

$$x_R = (11^2 - 3 - 9) \bmod 23 = 109 \bmod 23 = 17$$

$$y_R = (11(3 - 17) - 10) \bmod 23 = -164 \bmod 23 = 20$$

So $P + Q = (17, 20)$. To find $2P$,

$$\lambda = \left(\frac{3(3^2) + 1}{2 \times 10} \right) \bmod 23 = \left(\frac{5}{20} \right) \bmod 23 = \left(\frac{1}{4} \right) \bmod 23 = 6$$

The last step in the preceding equation involves taking the multiplicative inverse of 4 in \mathbb{Z}_{23} . This can be done using the extended Euclidean algorithm defined in Section 2.2. To confirm, note that $(6 \times 4) \bmod 23 = 24 \bmod 23 = 1$.

$$x_R = (6^2 - 3 - 3) \bmod 23 = 30 \bmod 23 = 7$$

$$y_R = (6(3 - 7) - 10) \bmod 23 = (-34) \bmod 23 = 12$$

and $2P = (7, 12)$.

For determining the security of various elliptic curve ciphers, it is of some interest to know the number of points in a finite abelian group defined over an elliptic curve. In the case of the finite group $E_p(a, b)$, the number of points N is bounded by

$$p + 1 - 2\sqrt{p} \leq N \leq p + 1 + 2\sqrt{p}$$

Note that the number of points in $E_p(a, b)$ is approximately equal to the number of elements in \mathbb{Z}_p , namely p elements.

Elliptic Curves over $\text{GF}(2^m)$

Recall from Chapter 5 that a **finite field** $\text{GF}(2^m)$ consists of 2^m elements, together with addition and multiplication operations that can be defined over polynomials. For elliptic curves over $\text{GF}(2^m)$, we use a cubic equation in which the variables and coefficients all take on values in $\text{GF}(2^m)$ for some number m and in which calculations are performed using the rules of arithmetic in $\text{GF}(2^m)$.

Table 10.2 Points (other than O) on the Elliptic Curve $E_{2^4}(g^4, 1)$

$(0, 1)$	(g^5, g^3)	(g^9, g^{13})
$(1, g^6)$	(g^5, g^{11})	(g^{10}, g)
$(1, g^{13})$	(g^6, g^8)	(g^{10}, g^8)
(g^3, g^8)	(g^6, g^{14})	$(g^{12}, 0)$
(g^3, g^{13})	(g^9, g^{10})	(g^{12}, g^{12})

It turns out that the form of cubic equation appropriate for cryptographic applications for elliptic curves is somewhat different for $\text{GF}(2^m)$ than for Z_p . The form is

$$y^2 + xy = x^3 + ax^2 + b \tag{10.7}$$

where it is understood that the variables x and y and the coefficients a and b are elements of $\text{GF}(2^m)$ and that calculations are performed in $\text{GF}(2^m)$.

Now consider the set $E_{2^m}(a, b)$ consisting of all pairs of integers (x, y) that satisfy Equation (10.7), together with a point at infinity O .

For example, let us use the finite field $\text{GF}(2^4)$ with the irreducible polynomial $f(x) = x^4 + x + 1$. This yields a generator g that satisfies $f(g) = 0$ with a value of $g^4 = g + 1$, or in binary, $g = 0010$. We can develop the powers of g as follows.

$g^0 = 0001$	$g^4 = 0011$	$g^8 = 0101$	$g^{12} = 1111$
$g^1 = 0010$	$g^5 = 0110$	$g^9 = 1010$	$g^{13} = 1101$
$g^2 = 0100$	$g^6 = 1100$	$g^{10} = 0111$	$g^{14} = 1001$
$g^3 = 1000$	$g^7 = 1011$	$g^{11} = 1110$	$g^{15} = 0001$

For example, $g^5 = (g^4)(g) = (g + 1)(g) = g^2 + g = 0110$.

Now consider the elliptic curve $y^2 + xy = x^3 + g^4x^2 + 1$. In this case, $a = g^4$ and $b = g^0 = 1$. One point that satisfies this equation is (g^5, g^3) :

$$\begin{aligned} (g^3)^2 + (g^5)(g^3) &= (g^5)^3 + (g^4)(g^5)^2 + 1 \\ g^6 + g^8 &= g^{15} + g^{14} + 1 \\ 1100 + 0101 &= 0001 + 1001 + 0001 \\ 1001 &= 1001 \end{aligned}$$

Table 10.2 lists the points (other than O) that are part of $E_{2^4}(g^4, 1)$. Figure 10.6 plots the points of $E_{2^4}(g^4, 1)$.

It can be shown that a finite abelian group can be defined based on the set $E_{2^m}(a, b)$, provided that $b \neq 0$. The rules for addition can be stated as follows. For all points $P, Q \in E_{2^m}(a, b)$:

1. $P + O = P$.
2. If $P = (x_P, y_P)$, then $P + (x_P, x_P + y_P) = O$. The point $(x_P, x_P + y_P)$ is the negative of P , which is denoted as $-P$.
3. If $P = (x_P, y_P)$ and $Q = (x_Q, y_Q)$ with $P \neq -Q$ and $P \neq Q$, then $R = P + Q = (x_R, y_R)$ is determined by the following rules:

$$\begin{aligned} x_R &= \lambda^2 + \lambda + x_P + x_Q + a \\ y_R &= \lambda(x_P + x_R) + x_R + y_P \end{aligned}$$

where

$$\lambda = \frac{y_Q + y_P}{x_Q + x_P}$$

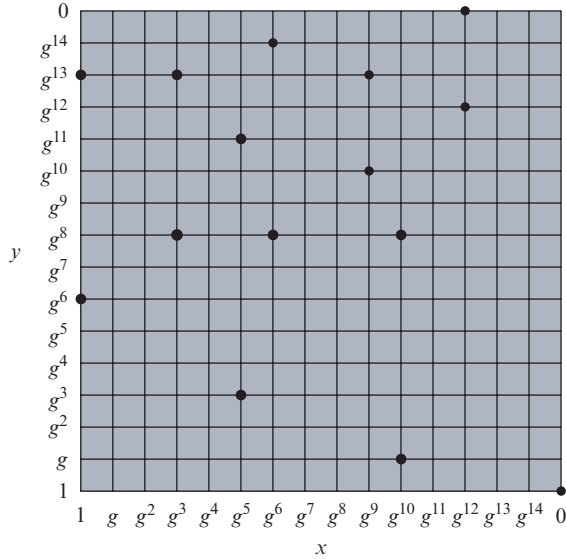

Figure 10.6 The Elliptic Curve E_{2⁴}(g⁴, 1)

4. If $P = (x_P, y_P)$ then $R = 2P = (x_R, y_R)$ is determined by the following rules:

$$x_R = \lambda^2 + \lambda + a$$

$$y_R = x_P^2 + (\lambda + 1)x_R$$

where

$$\lambda = x_P + \frac{y_P}{x_P}$$

10.4 ELLIPTIC CURVE CRYPTOGRAPHY

The addition operation in ECC is the counterpart of modular multiplication in RSA, and multiple addition is the counterpart of modular exponentiation. To form a cryptographic system using elliptic curves, we need to find a “hard problem” corresponding to factoring the product of two primes or taking the discrete logarithm.

Consider the equation $Q = kP$ where $Q, P \in E_p(a, b)$ and $k < p$. It is relatively easy to calculate Q given k and P , but it is hard to determine k given Q and P . This is called the discrete logarithm problem for elliptic curves.

We give an example taken from the Certicom Web site (www.certicom.com). Consider the group $E_{23}(9,17)$. This is the group defined by the equation $y^2 \text{ mod } 23 = (x^3 + 9x + 17) \text{ mod } 23$. What is the discrete logarithm k of $Q = (4, 5)$ to the base $P = (16, 5)$? The brute-force method is to compute multiples of P until Q is found. Thus,

$$P = (16, 5); 2P = (20, 20); 3P = (14, 14); 4P = (19, 20); 5P = (13, 10);$$

$$6P = (7, 3); 7P = (8, 7); 8P = (12, 17); 9P = (4, 5)$$

Because $9P = (4, 5) = Q$, the discrete logarithm $Q = (4, 5)$ to the base $P = (16, 5)$ is $k = 9$. In a real application, k would be so large as to make the brute-force approach infeasible.

In the remainder of this section, we show two approaches to ECC that give the flavor of this technique.

Analog of Diffie–Hellman Key Exchange

Key exchange using elliptic curves can be done in the following manner. First pick a large integer q , which is either a prime number p or an integer of the form 2^m , and elliptic curve parameters a and b for Equation (10.5) or Equation (10.7). This defines the elliptic group of points $E_q(a, b)$. Next, pick a *base point* $G = (x_1, y_1)$ in $E_p(a, b)$ whose order is a very large value n . The **order** n of a point G on an elliptic curve is the smallest positive integer n such that $nG = 0$ and G are parameters of the cryptosystem known to all participants.

A key exchange between users A and B can be accomplished as follows (Figure 10.7).

1. A selects an integer n_A less than n . This is A's private key. A then generates a public key $P_A = n_A \times G$; the public key is a point in $E_q(a, b)$.
2. B similarly selects a private key n_B and computes a public key P_B .
3. A generates the secret key $k = n_A \times P_B$. B generates the secret key $k = n_B \times P_A$.

The two calculations in step 3 produce the same result because

$$n_A \times P_B = n_A \times (n_B \times G) = n_B \times (n_A \times G) = n_B \times P_A$$

To break this scheme, an attacker would need to be able to compute k given G and kG , which is assumed to be hard.

As an example,⁴ take $p = 211$; $E_p(0, -4)$, which is equivalent to the curve $y^2 = x^3 - 4$; and $G = (2, 2)$. One can calculate that $240G = O$. A's private key is $n_A = 121$, so A's public key is $P_A = 121(2, 2) = (115, 48)$. B's private key is $n_B = 203$, so B's public key is $203(2, 3) = (130, 203)$. The shared secret key is $121(130, 203) = 203(115, 48) = (161, 69)$.

Note that the secret key is a pair of numbers. If this key is to be used as a session key for conventional encryption, then a single number must be generated. We could simply use the x coordinates or some simple function of the x coordinate.

Elliptic Curve Encryption/Decryption

Several approaches to encryption/decryption using elliptic curves have been analyzed in the literature. In this subsection, we look at perhaps the simplest. The first task in this system is to encode the plaintext message m to be sent as an (x, y) point P_m . It is the point P_m that will be encrypted as a ciphertext and subsequently decrypted. Note that we cannot simply encode the message as the x or y coordinate of a point, because not all such coordinates are in $E_q(a, b)$; for example, see

⁴Provided by Ed Schaefer of Santa Clara University.

Global Public Elements	
$E_q(a, b)$	elliptic curve with parameters a, b , and q , where q is a prime or an integer of the form 2^m
G	point on elliptic curve whose order is large value n

User A Key Generation	
Select private n_A	$n_A < n$
Calculate public P_A	$P_A = n_A \times G$

User B Key Generation	
Select private n_B	$n_B < n$
Calculate public P_B	$P_B = n_B \times G$

Calculation of Secret Key by User A	
$K = n_A \times P_B$	

Calculation of Secret Key by User B	
$K = n_B \times P_A$	

Figure 10.7 ECC Diffie–Hellman Key Exchange

Table 10.1. Again, there are several approaches to this encoding, which we will not address here, but suffice it to say that there are relatively straightforward techniques that can be used.

As with the key exchange system, an encryption/decryption system requires a point G and an elliptic group $E_q(a, b)$ as parameters. Each user A selects a private key n_A and generates a public key $P_A = n_A \times G$.

To encrypt and send a message P_m to B, A chooses a random positive integer k and produces the ciphertext C_m consisting of the pair of points:

$$C_m = \{kG, P_m + kP_B\}$$

Note that A has used B's public key P_B . To decrypt the ciphertext, B multiplies the first point in the pair by B's private key and subtracts the result from the second point:

$$P_m + kP_B - n_B(kG) = P_m + k(n_BG) - n_B(kG) = P_m$$

A has masked the message P_m by adding kP_B to it. Nobody but A knows the value of k , so even though P_b is a public key, nobody can remove the mask kP_B .

Table 10.3 Comparable Key Sizes in Terms of Computational Effort for Cryptanalysis (NIST SP-800-57)

Symmetric Key Algorithms	Diffie–Hellman, Digital Signature Algorithm	RSA (size of n in bits)	ECC (modulus size in bits)
80	$L = 1024$ $N = 160$	1024	160–223
112	$L = 2048$ $N = 224$	2048	224–255
128	$L = 3072$ $N = 256$	3072	256–383
192	$L = 7680$ $N = 384$	7680	384–511
256	$L = 15,360$ $N = 512$	15,360	512+

Note: L = size of public key, N = size of private key.

However, A also includes a “clue,” which is enough to remove the mask if one knows the private key n_B . For an attacker to recover the message, the attacker would have to compute k given G and kG , which is assumed to be hard.

Let us consider a simple example. The global public elements are $q = 257$; $E_q(a, b) = E_{257}(0, -4)$, which is equivalent to the curve $y^2 = x^3 - 4$; and $G = (2, 2)$. Bob’s private key is $n_B = 101$, and his public key is $P_B = n_B G = 101(2, 2) = (197, 167)$. Alice wishes to send a message to Bob that is encoded in the elliptic point $P_m = (112, 26)$. Alice chooses random integer $k = 41$ and computes $kG = 41(2, 2) = (136, 128)$, $kP_B = 41(197, 167) = (68, 84)$ and $P_m + kP_B = (112, 26) + (68, 84) = (246, 174)$. Alice sends the ciphertext $C_m = (C_1, C_2) = \{(136, 128), (246, 174)\}$ to Bob. Bob receives the ciphertext and computes $C_2 - n_B C_1 = (246, 174) - 101(136, 128) = (246, 174) - (68, 84) = (112, 26)$.

Security of Elliptic Curve Cryptography

The security of ECC depends on how difficult it is to determine k given kP and P . This is referred to as the elliptic curve logarithm problem. The fastest known technique for taking the elliptic curve logarithm is known as the Pollard rho method. Table 10.3, from NIST SP 800-57 (*Recommendation for Key Management—Part 1: General*, September 2015), compares various algorithms by showing comparable key sizes in terms of computational effort for cryptanalysis. As can be seen, a considerably smaller key size can be used for ECC compared to RSA.

Based on this analysis, SP 800-57 recommends that at least through 2030, acceptable key lengths are from 3072 to 14,360 bits for RSA and 256 to 512 bits for ECC. Similarly, the European Union Agency for Network and Information Security (ENISA) recommends in their 2014 report (*Algorithms, Key Size and Parameters report—2014*, November 2014) minimum key lengths for future system of 3072 bits and 256 bits for RSA and ECC, respectively.

Analysis indicates that for equal key lengths, the computational effort required for ECC and RSA is comparable [JUR197]. Thus, there is a computational advantage to using ECC with a shorter key length than a comparably secure RSA.

10.5 KEY TERMS, REVIEW QUESTIONS, AND PROBLEMS

Key Terms

discrete logarithm elliptic curve	elliptic curve cryptography finite field	man-in-the-middle attack primitive root
--------------------------------------	---	--

Review Questions

- 10.1** What is the relation between the security of the Diffie–Hellman key exchange and the difficulty of computing discrete logarithms?
- 10.2** Explain the security of the elliptic curve cryptography (ECC) and how it compares to the security of RSA.
- 10.3** What is the zero point of an elliptic curve?
- 10.4** What is the sum of three points on an elliptic curve that lie on a straight line?

Problems

- 10.1** Alice and Bob use the Diffie–Hellman key exchange technique with a common prime $q = 157$ and a primitive root $\alpha = 5$.
 - a.** If Alice has a private key $X_A = 15$, find her public key Y_A .
 - b.** If Bob has a private key $X_B = 27$, find his public key Y_B .
 - c.** What is the shared secret key between Alice and Bob?
- 10.2** Alice and Bob use the Diffie–Hellman key exchange technique with a common prime $q = 23$ and a primitive root $\alpha = 5$.
 - a.** If Bob has a public key $Y_B = 10$, what is Bob’s private key X_B ?
 - b.** If Alice has a public key $Y_A = 8$, what is the shared key K with Bob?
 - c.** Show that 5 is a primitive root of 23.
- 10.3** In the Diffie–Hellman protocol, each participant selects a secret number x and sends the other participant $\alpha^x \bmod q$ for some public number α . What would happen if the participants sent each other x^α for some public number α instead? Give at least one method Alice and Bob could use to agree on a key. Can Darth break your system without finding the secret numbers? Can Darth find the secret numbers?
- 10.4** This problem illustrates the point that the Diffie–Hellman protocol is not secure without the step where you take the modulus; i.e. the “Indiscrete Log Problem” is not a hard problem! You are Darth and have captured Alice and Bob and imprisoned them. You overhear the following dialog.

Bob: Oh, let’s not bother with the prime in the Diffie–Hellman protocol, it will make things easier.

Alice: Okay, but we still need a base α to raise things to. How about $\alpha = 3$?

Bob: All right, then my result is 27.

Alice: And mine is 243.

What is Bob’s private key X_B and Alice’s private key X_A ? What is their secret combined key? (Don’t forget to show your work.)

- 10.5** Section 10.1 describes a man-in-the-middle attack on the Diffie–Hellman key exchange protocol in which the adversary generates two public–private key pairs for the attack. Could the same attack be accomplished with one pair? Explain.

- 10.6** Suppose Alice and Bob use an ElGamal scheme with a common prime $q = 157$ and a primitive root $\alpha = 5$.
- If Bob has public key $Y_B = 10$ and Alice chose the random integer $k = 3$, what is the ciphertext of $M = 9$?
 - If Alice now chooses a different value of k so that the encoding of $M = 9$ is $C = (25, C_2)$, what is the integer C_2 ?
- 10.7** Rule (5) for doing arithmetic in elliptic curves over real numbers states that to double a point Q_2 , draw the tangent line and find the other point of intersection S . Then $Q + Q = 2Q = -S$. If the tangent line is not vertical, there will be exactly one point of intersection. However, suppose the tangent line is vertical? In that case, what is the value $2Q$? What is the value $3Q$?
- 10.8** Demonstrate that the two elliptic curves of Figure 10.4 each satisfy the conditions for a group over the real numbers.
- 10.9** Is $(5, 12)$ a point on the elliptic curve $y^2 = x^3 + 4x - 1$ over real numbers?
- 10.10** On the elliptic curve over the real numbers $y^2 = x^3 - \frac{17}{12}x + 1$, let $P = (0, 1)$ and $Q = (1.5, 1.5)$. Find $P + Q$ and $2P$.
- 10.11** Does the elliptic curve equation $y^2 = x^3 + x + 2$ define a group over Z_7 ?
- 10.12** Consider the elliptic curve $E_7(2, 1)$; that is, the curve is defined by $y^2 = x^3 + 2x + 1$ with a modulus of $p = 7$. Determine all of the points in $E_7(2, 1)$. *Hint:* Start by calculating the right-hand side of the equation for all values of x .
- 10.13** What are the negatives of the following elliptic curve points over Z_7 ? $P = (3, 5)$; $Q = (2, 5)$; and $R = (5, 0)$.
- 10.14** For $E_{11}(1, 7)$, consider the point $G = (3, 2)$. Compute the multiple of G from $2G$ through $13G$.
- 10.15** This problem performs elliptic curve encryption/decryption using the scheme outlined in Section 10.4. The cryptosystem parameters are $E_{11}(1, 7)$ and $G = (3, 2)$. B's private key is $n_B = 7$.
- Find B's public key P_B .
 - A wishes to encrypt the message $P_m = (10, 7)$ and chooses the random value $k = 5$. Determine the ciphertext C_m .
 - Show the calculation by which B recovers P_m from C_m .
- 10.16** The following is a first attempt at an elliptic curve signature scheme. We have a global elliptic curve, prime p , and "generator" G . Alice picks a private signing key X_A and forms the public verifying key $Y_A = X_A G$. To sign a message M :
- Alice picks a value k .
 - Alice sends Bob M, k , and the signature $S = M - kX_A G$.
 - Bob verifies that $M = S + kY_A$.
- Show that this scheme works. That is, show that the verification process produces an equality if the signature is valid.
 - Show that the scheme is unacceptable by describing a simple technique for forging a user's signature on an arbitrary message.
- 10.17** Here is an improved version of the scheme given in the previous problem. As before, we have a global elliptic curve, prime p , and "generator" G . Alice picks a private signing key X_A and forms the public verifying key $Y_A = X_A G$. To sign a message M :
- Bob picks a value k .
 - Bob sends Alice $C_1 = kG$.
 - Alice sends Bob M and the signature $S = M - X_A C_1$.
 - Bob verifies that $M = S + kY_A$.
- Show that this scheme works. That is, show that the verification process produces an equality if the signature is valid.
 - Show that forging a message in this scheme is as hard as breaking (ElGamal) elliptic curve cryptography. (Or find an easier way to forge a message?)
 - This scheme has an extra "pass" compared to other cryptosystems and signature schemes we have looked at. What are some drawbacks to this?

CRYPTOGRAPHIC HASH FUNCTIONS

11.1 Applications of Cryptographic Hash Functions

- Message Authentication
- Digital Signatures
- Other Applications

11.2 Two Simple Hash Functions

11.3 Requirements and Security

- Security Requirements for Cryptographic Hash Functions
- Brute-Force Attacks
- Cryptanalysis

11.4 Secure Hash Algorithm (SHA)

- SHA-512 Logic
- SHA-512 Round Function
- Example

11.5 SHA-3

- The Sponge Construction
- The SHA-3 Iteration Function f

11.6 Key Terms, Review Questions, and Problems

LEARNING OBJECTIVES

After studying this chapter, you should be able to:

- ◆ Summarize the applications of cryptographic hash functions.
- ◆ Explain why a hash function used for message authentication needs to be secured.
- ◆ Understand the differences among preimage resistant, second preimage resistant, and collision resistant properties.
- ◆ Present an overview of the basic structure of cryptographic hash functions.
- ◆ Describe how cipher block chaining can be used to construct a hash function.
- ◆ Understand the operation of SHA-512.

A **hash function** H accepts a variable-length block of data M as input and produces a fixed-size result $h = H(M)$, referred to as a **hash value** or a **hash code**. A “good” hash function has the property that the results of applying the function to a large set of inputs will produce outputs that are evenly distributed and apparently random. In general terms, the principal object of a hash function is data integrity. A change to any bit or bits in M results, with high probability, in a change to the hash value.

The kind of hash function needed for security applications is referred to as a **cryptographic hash function**. A cryptographic hash function is an algorithm for which it is computationally infeasible (because no attack is significantly more efficient than brute force) to find either (a) a data object that maps to a pre-specified hash result (the one-way property) or (b) two data objects that map to the same hash result (the collision-free property). Because of these characteristics, hash functions are often used to determine whether or not data has changed.

Figure 11.1 depicts the general operation of a cryptographic hash function. Typically, the input is padded out to an integer multiple of some fixed length (e.g., 1024 bits), and the padding includes the value of the length of the original message in bits. The length field is a security measure to increase the difficulty for an attacker to produce an alternative message with the same hash value, as explained subsequently.

This chapter begins with a discussion of the wide variety of applications for cryptographic hash functions. Next, we look at the security requirements for such functions. Then we look at the use of cipher block chaining to implement a cryptographic hash function. The remainder of the chapter is devoted to the most important and widely used family of cryptographic hash functions, the Secure Hash Algorithm (SHA) family.

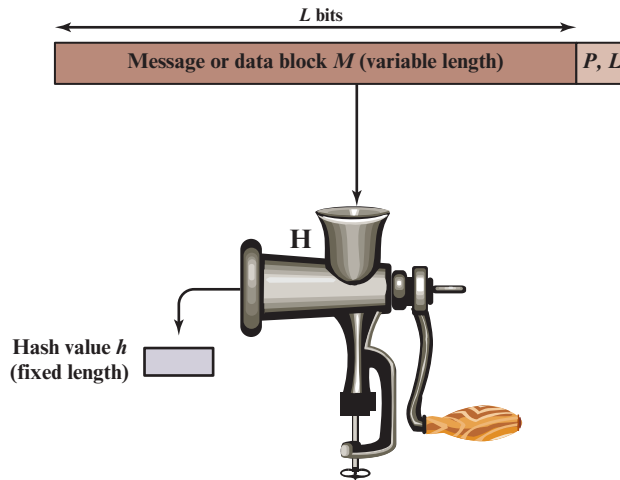

P, L = padding plus length field

Figure 11.1 Cryptographic Hash Function; $h = H(M)$

11.1 APPLICATIONS OF CRYPTOGRAPHIC HASH FUNCTIONS

Perhaps the most versatile cryptographic algorithm is the cryptographic hash function. It is used in a wide variety of security applications and Internet protocols. To better understand some of the requirements and security implications for cryptographic hash functions, it is useful to look at the range of applications in which it is employed.

Message Authentication

Message authentication is a mechanism or service used to verify the integrity of a message. Message authentication assures that data received are exactly as sent (i.e., there is no modification, insertion, deletion, or replay). In many cases, there is a requirement that the authentication mechanism assures that the purported identity of the sender is valid. When a hash function is used to provide message authentication, the hash function value is often referred to as a **message digest**.¹

The essence of the use of a hash function for message integrity is as follows. The sender computes a hash value as a function of the bits in the message and transmits both the hash value and the message. The receiver performs the same hash calculation on the message bits and compares this value with the incoming hash value.

¹The topic of this section is invariably referred to as message authentication. However, the concepts and techniques apply equally to data at rest. For example, authentication techniques can be applied to a file in storage to assure that the file is not tampered with.

If there is a mismatch, the receiver knows that the message (or possibly the hash value) has been altered (Figure 11.2a).

The hash value must be transmitted in a secure fashion. That is, the hash value must be protected so that if an adversary alters or replaces the message, it is not feasible for adversary to also alter the hash value to fool the receiver. This type of attack is shown in Figure 11.2b. In this example, Alice transmits a data block and attaches a hash value. Darth intercepts the message, alters or replaces the data block, and calculates and attaches a new hash value. Bob receives the altered data with the new hash value and does not detect the change. To prevent this attack, the hash value generated by Alice must be protected.

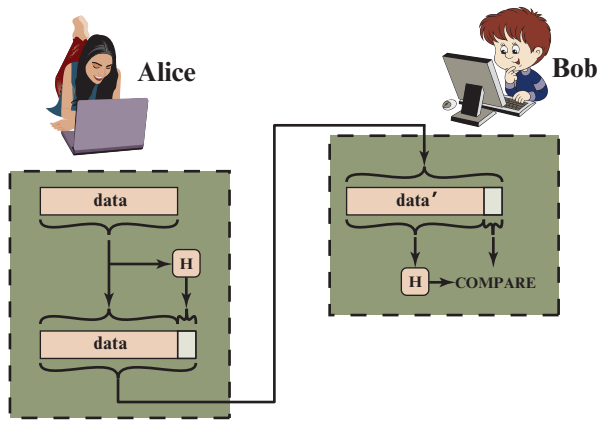

(a) Use of hash function to check data integrity

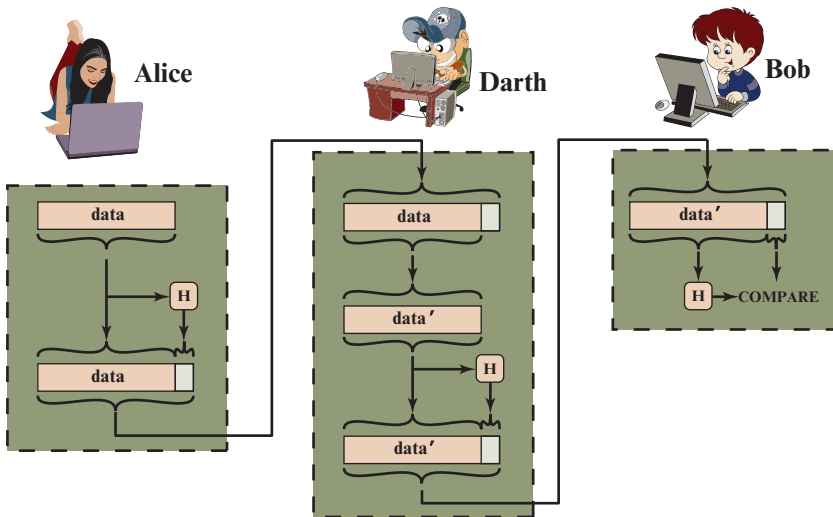

(b) Man-in-the-middle attack

Figure 11.2 Attack Against Hash Function

Figure 11.3 illustrates a variety of ways in which a hash code can be used to provide message authentication, as follows.

- a. The message plus concatenated hash code is encrypted using symmetric encryption. Because only A and B share the secret key, the message must have come from A and has not been altered. The hash code provides the structure or redundancy required to achieve authentication. Because encryption is applied to the entire message plus hash code, confidentiality is also provided.
- b. Only the hash code is encrypted, using symmetric encryption. This reduces the processing burden for those applications that do not require confidentiality.

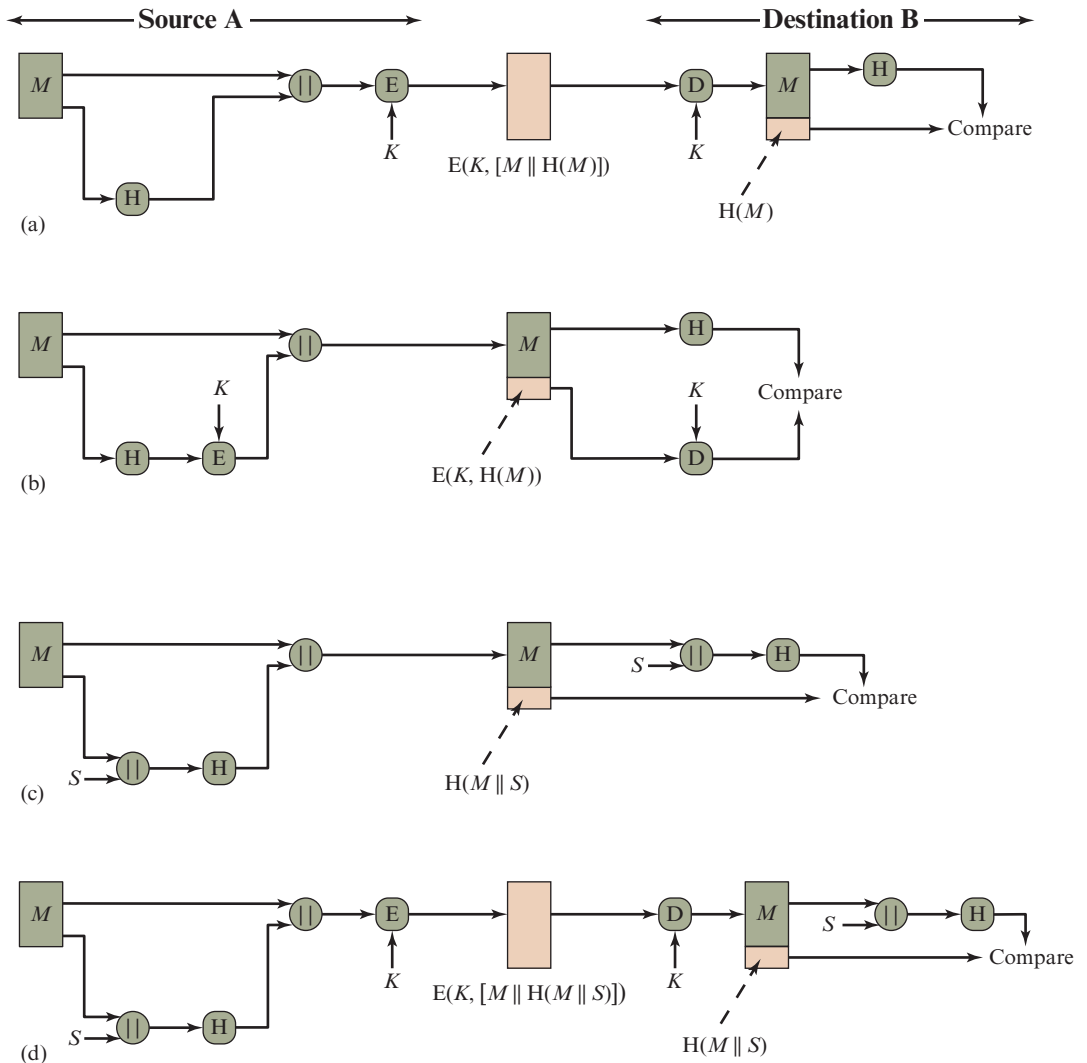

Figure 11.3 Simplified Examples of the Use of a Hash Function for Message Authentication

- c. It is possible to use a hash function but no encryption for message authentication. The technique assumes that the two communicating parties share a common secret value S . A computes the hash value over the concatenation of M and S and appends the resulting hash value to M . Because B possesses S , it can recompute the hash value to verify. Because the secret value itself is not sent, an opponent cannot modify an intercepted message and cannot generate a false message.
- d. Confidentiality can be added to the approach of method (c) by encrypting the entire message plus the hash code.

When confidentiality is not required, method (b) has an advantage over methods (a) and (d), which encrypts the entire message, in that less computation is required. Nevertheless, there has been growing interest in techniques that avoid encryption (Figure 11.3c). Several reasons for this interest are pointed out in [TSUD92].

- Encryption software is relatively slow. Even though the amount of data to be encrypted per message is small, there may be a steady stream of messages into and out of a system.
- Encryption hardware costs are not negligible. Low-cost chip implementations of DES are available, but the cost adds up if all nodes in a network must have this capability.
- Encryption hardware is optimized toward large data sizes. For small blocks of data, a high proportion of the time is spent in initialization/invocation overhead.
- Encryption algorithms may be covered by patents, and there is a cost associated with licensing their use.

More commonly, message authentication is achieved using a **message authentication code (MAC)**, also known as a keyed hash function. Typically, MACs are used between two parties that share a secret key to authenticate information exchanged between those parties. A MAC function takes as input a secret key and a data block and produces a hash value, referred to as the MAC, which is associated with the protected message. If the integrity of the message needs to be checked, the MAC function can be applied to the message and the result compared with the associated MAC value. An attacker who alters the message will be unable to alter the associated MAC value without knowledge of the secret key. Note that the verifying party also knows who the sending party is because no one else knows the secret key.

Note that the combination of hashing and encryption results in an overall function that is, in fact, a MAC (Figure 11.3b). That is, $E(K, H(M))$ is a function of a variable-length message M and a secret key K , and it produces a fixed-size output that is secure against an opponent who does not know the secret key. In practice, specific MAC algorithms are designed that are generally more efficient than an encryption algorithm.

We discuss MACs in Chapter 12.

Digital Signatures

Another important application, which is similar to the message authentication application, is the **digital signature**. The operation of the digital signature is similar to that of the MAC. In the case of the digital signature, the hash value of a message

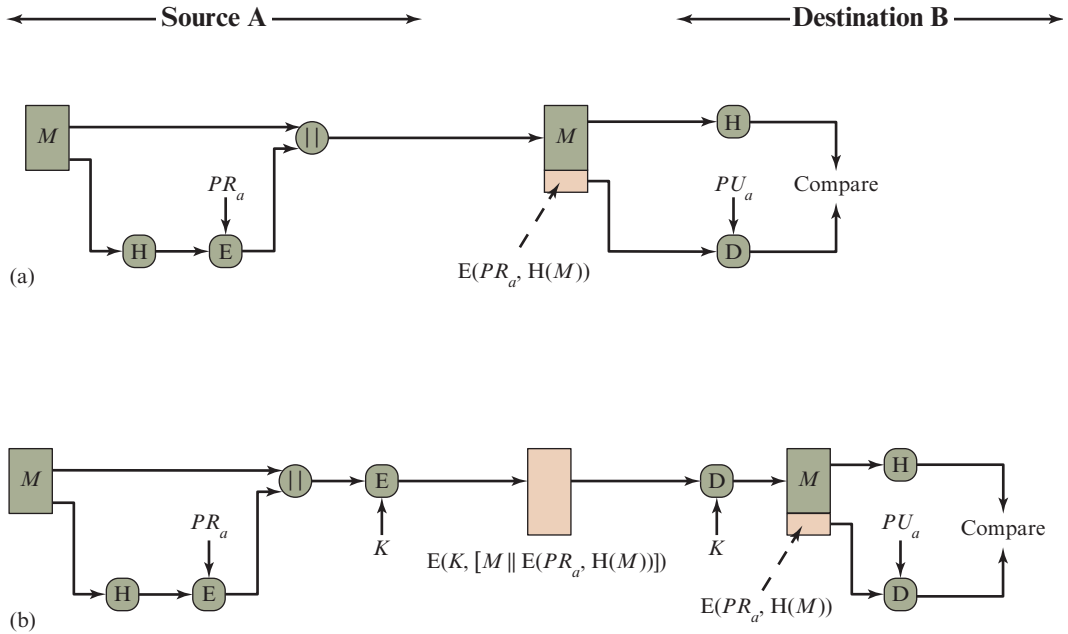

Figure 11.4 Simplified Examples of Digital Signatures

is encrypted with a user’s private key. Anyone who knows the user’s public key can verify the integrity of the message that is associated with the digital signature. In this case, an attacker who wishes to alter the message would need to know the user’s private key. As we shall see in Chapter 14, the implications of digital signatures go beyond just message authentication.

Figure 11.4 illustrates, in a simplified fashion, how a hash code is used to provide a digital signature.

- a. The hash code is encrypted, using public-key encryption with the sender’s private key. As with Figure 11.3b, this provides authentication. It also provides a digital signature, because only the sender could have produced the encrypted hash code. In fact, this is the essence of the digital signature technique.
- b. If confidentiality as well as a digital signature is desired, then the message plus the private-key-encrypted hash code can be encrypted using a symmetric secret key. This is a common technique.

Other Applications

Hash functions are commonly used to create a one-way password file. Chapter 24 explains a scheme in which a hash of a password is stored by an operating system rather than the password itself. Thus, the actual password is not retrievable by a hacker who gains access to the password file. In simple terms, when a user enters a password, the hash of that password is compared to the stored hash value for verification. This approach to password protection is used by most operating systems.

Hash functions can be used for **intrusion detection** and **virus detection**. Store $H(F)$ for each file on a system and secure the hash values (e.g., on a CD-R that is kept secure). One can later determine if a file has been modified by recomputing $H(F)$. An intruder would need to change F without changing $H(F)$.

A cryptographic hash function can be used to construct a **pseudorandom function (PRF)** or a **pseudorandom number generator (PRNG)**. A common application for a hash-based PRF is for the generation of symmetric keys. We discuss this application in Chapter 12.

11.2 TWO SIMPLE HASH FUNCTIONS

To get some feel for the security considerations involved in cryptographic hash functions, we present two simple, insecure hash functions in this section. All hash functions operate using the following general principles. The input (message, file, etc.) is viewed as a sequence of n -bit blocks. The input is processed one block at a time in an iterative fashion to produce an n -bit hash function.

One of the simplest hash functions is the bit-by-bit exclusive-OR (XOR) of every block. This can be expressed as

$$C_i = b_{i1} \oplus b_{i2} \oplus \cdots \oplus b_{im}$$

where

C_i = i th bit of the hash code, $1 \leq i \leq n$

m = number of n -bit blocks in the input

b_{ij} = i th bit in j th block

\oplus = XOR operation

This operation produces a simple parity bit for each bit position and is known as a longitudinal redundancy check. It is reasonably effective for random data as a data integrity check. Each n -bit hash value is equally likely. Thus, the probability that a data error will result in an unchanged hash value is 2^{-n} . With more predictably formatted data, the function is less effective. For example, in most normal text files, the high-order bit of each octet is always zero. So if a 128-bit hash value is used, instead of an effectiveness of 2^{-128} , the hash function on this type of data has an effectiveness of 2^{-112} .

A simple way to improve matters is to perform a one-bit circular shift, or rotation, on the hash value after each block is processed. The procedure can be summarized as follows.

1. Initially set the n -bit hash value to zero.
2. Process each successive n -bit block of data as follows:
 - a. Rotate the current hash value to the left by one bit.
 - b. XOR the block into the hash value.

This has the effect of “randomizing” the input more completely and overcoming any regularities that appear in the input. Figure 11.5 illustrates these two types of hash functions for 16-bit hash values.

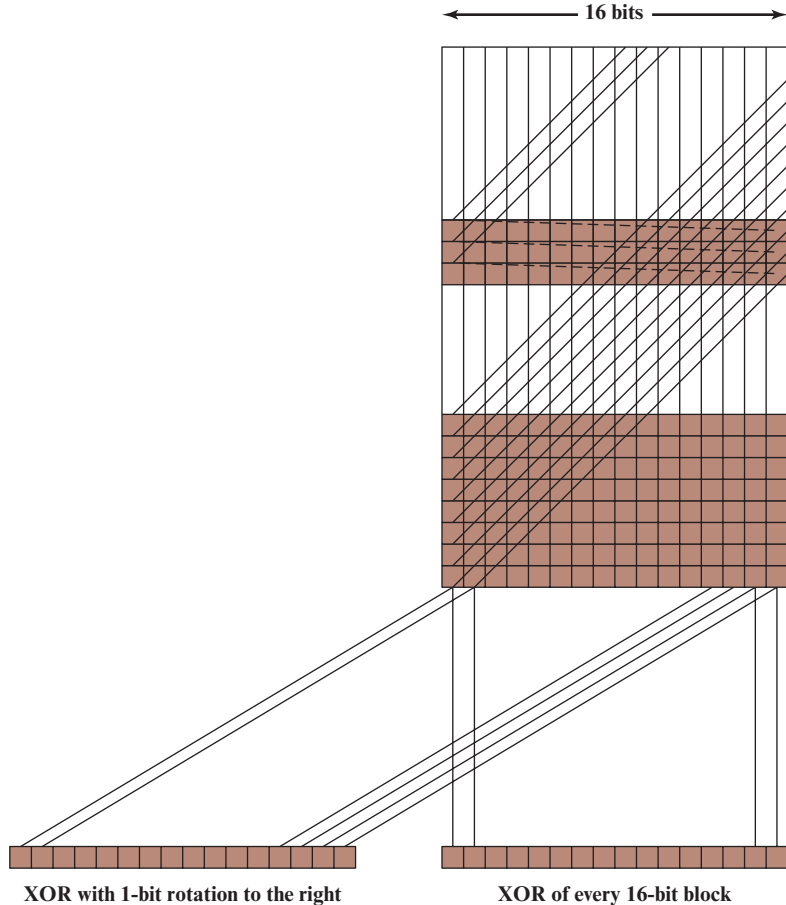

Figure 11.5 Two Simple Hash Functions

Although the second procedure provides a good measure of data integrity, it is virtually useless for data security when an encrypted hash code is used with a plaintext message, as in Figures 11.3b and 11.4a. Given a message, it is an easy matter to produce a new message that yields that hash code: Simply prepare the desired alternate message and then append an n -bit block that forces the new message plus block to yield the desired hash code.

Although a simple XOR or rotated XOR (RXOR) is insufficient if only the hash code is encrypted, you may still feel that such a simple function could be useful when the message together with the hash code is encrypted (Figure 11.3a). But you must be careful. A technique originally proposed by the National Bureau of Standards used the simple XOR applied to 64-bit blocks of the message and then an encryption of the entire message that used the cipher block chaining (CBC) mode. We can define the scheme as follows: Given a message M consisting of a sequence of 64-bit blocks X_1, X_2, \dots, X_N , define the hash code $h = H(M)$

as the block-by-block XOR of all blocks and append the hash code as the final block:

$$h = X_{N+1} = X_1 \oplus X_2 \oplus \dots \oplus X_N$$

Next, encrypt the entire message plus hash code using CBC mode to produce the encrypted message Y_1, Y_2, \dots, Y_{N+1} . [JUEN85] points out several ways in which the ciphertext of this message can be manipulated in such a way that it is not detectable by the hash code. For example, by the definition of CBC (Figure 6.4), we have

$$\begin{aligned} X_1 &= IV \oplus D(K, Y_1) \\ X_i &= Y_{i-1} \oplus D(K, Y_i) \\ X_{N+1} &= Y_N \oplus D(K, Y_{N+1}) \end{aligned}$$

But X_{N+1} is the hash code:

$$\begin{aligned} X_{N+1} &= X_1 \oplus X_2 \oplus \dots \oplus X_N \\ &= [IV \oplus D(K, Y_1)] \oplus [Y_1 \oplus D(K, Y_2)] \oplus \dots \oplus [Y_{N-1} \oplus D(K, Y_N)] \end{aligned}$$

Because the terms in the preceding equation can be XORed in any order, it follows that the hash code would not change if the ciphertext blocks were permuted.

11.3 REQUIREMENTS AND SECURITY

Before proceeding, we need to define two terms. For a hash value $h = H(x)$, we say that x is the **preimage** of h . That is, x is a data block whose hash value, using the function H , is h . Because H is a many-to-one mapping, for any given hash value h , there will in general be multiple preimages. A **collision** occurs if we have $x \neq y$ and $H(x) = H(y)$. Because we are using hash functions for data integrity, collisions are clearly undesirable.

Let us consider how many preimages are there for a given hash value, which is a measure of the number of potential collisions for a given hash value. Suppose the length of the hash code is n bits, and the function H takes as input messages or data blocks of length b bits with $b > n$. Then, the total number of possible messages is 2^b and the total number of possible hash values is 2^n . On average, each hash value corresponds to 2^{b-n} preimages. If H tends to uniformly distribute hash values then, in fact, each hash value will have close to 2^{b-n} preimages. If we now allow inputs of arbitrary length, not just a fixed length of some number of bits, then the number of preimages per hash value is arbitrarily large. However, the security risks in the use of a hash function are not as severe as they might appear from this analysis. To understand better the security implications of cryptographic hash functions, we need to precisely define their security requirements.

Security Requirements for Cryptographic Hash Functions

Table 11.1 lists the generally accepted requirements for a cryptographic hash function. The first three properties are requirements for the practical application of a hash function.

Table 11.1 Requirements for a Cryptographic Hash Function H

Requirement	Description
Variable input size	H can be applied to a block of data of any size.
Fixed output size	H produces a fixed-length output.
Efficiency	$H(x)$ is relatively easy to compute for any given x , making both hardware and software implementations practical.
Preimage resistant (one-way property)	For any given hash value h , it is computationally infeasible to find y such that $H(y) = h$.
Second preimage resistant (weak collision resistant)	For any given block x , it is computationally infeasible to find $y \neq x$ with $H(y) = H(x)$.
Collision resistant (strong collision resistant)	It is computationally infeasible to find any pair (x, y) with $x \neq y$, such that $H(x) = H(y)$.
Pseudorandomness	Output of H meets standard tests for pseudorandomness.

The fourth property, preimage resistant, is the one-way property: it is easy to generate a code given a message, but virtually impossible to generate a message given a code. This property is important if the authentication technique involves the use of a secret value (Figure 11.3c). The secret value itself is not sent. However, if the hash function is not one way, an attacker can easily discover the secret value: If the attacker can observe or intercept a transmission, the attacker obtains the message M , and the hash code $h = H(S \parallel M)$. The attacker then inverts the hash function to obtain $S \parallel M = H^{-1}(MD_M)$. Because the attacker now has both M and $S \parallel M$, it is a trivial matter to recover S .

The fifth property, second preimage resistant, guarantees that it is infeasible to find an alternative message with the same hash value as a given message. This prevents forgery when an encrypted hash code is used (Figures 11.3b and 11.4a). If this property were not true, an attacker would be capable of the following sequence: First, observe or intercept a message plus its encrypted hash code; second, generate an unencrypted hash code from the message; third, generate an alternate message with the same hash code.

A hash function that satisfies the first five properties in Table 11.1 is referred to as a weak hash function. If the sixth property, collision resistant, is also satisfied, then it is referred to as a strong hash function. A strong hash function protects against an attack in which one party generates a message for another party to sign. For example, suppose Bob writes an IOU message, sends it to Alice, and she signs it. Bob finds two messages with the same hash, one of which requires Alice to pay a small amount and one that requires a large payment. Alice signs the first message, and Bob is then able to claim that the second message is authentic.

Figure 11.6 shows the relationships among the three resistant properties. A function that is collision resistant is also second preimage resistant, but the reverse is not necessarily true. A function can be collision resistant but not preimage resistant and vice versa. A function can be preimage resistant but not second preimage resistant and vice versa. See [MENE97] for a discussion.

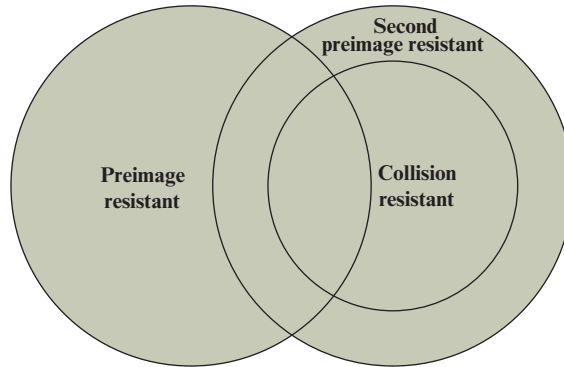

Figure 11.6 Relationship Among Hash Function Properties

Table 11.2 Hash Function Resistance Properties Required for Various Data Integrity Applications

	Preimage Resistant	Second Preimage Resistant	Collision Resistant
Hash + digital signature	yes	yes	yes*
Intrusion detection and virus detection		yes	
Hash + symmetric encryption			
One-way password file	yes		
MAC	yes	yes	yes*

*Resistance required if attacker is able to mount a chosen message attack

Table 11.2 shows the resistant properties required for various hash function applications.

The final requirement in Table 11.1, **pseudorandomness**, has not traditionally been listed as a requirement of cryptographic hash functions but is more or less implied. [JOHN05] points out that cryptographic hash functions are commonly used for key derivation and pseudorandom number generation, and that in message integrity applications, the three resistant properties depend on the output of the hash function appearing to be random. Thus, it makes sense to verify that in fact a given hash function produces pseudorandom output.

Brute-Force Attacks

As with encryption algorithms, there are two categories of attacks on hash functions: brute-force attacks and cryptanalysis. A brute-force attack does not depend on the specific algorithm but depends only on bit length. In the case of a hash function, a brute-force attack depends only on the bit length of the hash value. A cryptanalysis, in contrast, is an attack based on weaknesses in a particular cryptographic algorithm. We look first at brute-force attacks.

PREIMAGE AND SECOND PREIMAGE ATTACKS For a preimage or second preimage attack, an adversary wishes to find a value y such that $H(y)$ is equal to a given hash value h . The brute-force method is to pick values of y at random and try each value until a collision occurs. For an m -bit hash value, the level of effort is proportional to 2^m . Specifically, the adversary would have to try, on average, 2^{m-1} values of y to find one that generates a given hash value h . This result is derived in Appendix E [Equation (E.1)].

COLLISION RESISTANT ATTACKS For a collision resistant attack, an adversary wishes to find two messages or data blocks, x and y , that yield the same hash function: $H(x) = H(y)$. This turns out to require considerably less effort than a preimage or second preimage attack. The effort required is explained by a mathematical result referred to as the birthday paradox. In essence, if we choose random variables from a uniform distribution in the range 0 through $N - 1$, then the probability that a repeated element is encountered exceeds 0.5 after \sqrt{N} choices have been made. Thus, for an m -bit hash value, if we pick data blocks at random, we can expect to find two data blocks with the same hash value within $\sqrt{2^m} = 2^{m/2}$ attempts. The mathematical derivation of this result is found in Appendix E.

Yuval proposed the following strategy to exploit the birthday paradox in a collision resistant attack [YUVA79].

1. The source, A, is prepared to sign a legitimate message x by appending the appropriate m -bit hash code and encrypting that hash code with A's private key (Figure 11.4a).
2. The opponent generates $2^{m/2}$ variations x' of x , all of which convey essentially the same meaning, and stores the messages and their hash values.
3. The opponent prepares a fraudulent message y for which A's signature is desired.
4. The opponent generates minor variations y' of y , all of which convey essentially the same meaning. For each y' , the opponent computes $H(y')$, checks for matches with any of the $H(x')$ values, and continues until a match is found. That is, the process continues until a y' is generated with a hash value equal to the hash value of one of the x' values.
5. The opponent offers the valid variation to A for signature. This signature can then be attached to the fraudulent variation for transmission to the intended recipient. Because the two variations have the same hash code, they will produce the same signature; the opponent is assured of success even though the encryption key is not known.

Thus, if a 64-bit hash code is used, the level of effort required is only on the order of 2^{32} [see Appendix E, Equation (E.7)].

The generation of many variations that convey the same meaning is not difficult. For example, the opponent could insert a number of "space-space-backspace" character pairs between words throughout the document. Variations could then be generated by substituting "space-backspace-space" in selected instances. Alternatively,

the opponent could simply reword the message but retain the meaning. Figure 11.7 provides an example.

To summarize, for a hash code of length m , the level of effort required, as we have seen, is proportional to the following.

Preimage resistant	2^m
Second preimage resistant	2^m
Collision resistant	$2^{m/2}$

As { the } Dean of Blakewell College, I have { had the pleasure of knowing } Cherise
 Rosetti for the { last } four years. She { has been } { a tremendous } { asset to }
 { past } { was } { an outstanding } { role model in }
 { our } school. I { would like to take this opportunity to } recommend Cherise for your
 { the } { wholeheartedly }
 { school's } graduate program. I { am } { confident } { that } { she } will
 { — } { feel } { certain } { — } { Cherise }
 { continue to } succeed in her studies. { She } is a dedicated student and
 { — } { Cherise }
 { thus far her grades } { have been } { exemplary } . In class,
 { her grades thus far } { are } { excellent }
 { she } { has proven to be } a take-charge { person } { who is } able to
 { Cherise } { has been } { individual } { — }
 successfully develop plans and implement them.
 { She } has also assisted { us } in our admissions office. { She } has
 { Cherise } { — } { Cherise }
 { successfully } demonstrated leadership ability by counseling new and prospective students.
 { Her } advice has been { a great } help to these students, many of whom
 { Cherise's } { of considerable }
 have { taken time to share } their comments with me regarding her pleasant and
 { shared }
 { encouraging } attitude. { For these reasons } I
 { reassuring } { It is for these reasons that }
 { highly recommend } Cherise { without reservation } . Her { ambition } and
 { offer high recommendations for } { unreservedly } { drive }
 { abilities } will { truly } be an { asset to } your { establishment } .
 { potential } { surely } { plus for } { school }

Figure 11.7 A Letter in 2^{38} Variations

If collision resistance is required (and this is desirable for a general-purpose secure hash code), then the value $2^{m/2}$ determines the strength of the hash code against brute-force attacks. Van Oorschot and Wiener [VANO94] presented a design for a \$10 million collision search machine for MD5, which has a 128-bit hash length, that could find a collision in 24 days. Thus, a 128-bit code may be viewed as inadequate. The next step up, if a hash code is treated as a sequence of 32 bits, is a 160-bit hash length. With a hash length of 160 bits, the same search machine would require over four thousand years to find a collision. With today's technology, the time would be much shorter, so that 160 bits now appears suspect.

Cryptanalysis

As with encryption algorithms, cryptanalytic attacks on hash functions seek to exploit some property of the algorithm to perform some attack other than an exhaustive search. The way to measure the resistance of a hash algorithm to cryptanalysis is to compare its strength to the effort required for a brute-force attack. That is, an ideal hash algorithm will require a cryptanalytic effort greater than or equal to the brute-force effort.

In recent years, there has been considerable effort, and some successes, in developing cryptanalytic attacks on hash functions. To understand these, we need to look at the overall structure of a typical secure hash function, indicated in Figure 11.8. This structure, referred to as an iterated hash function, was proposed by Merkle [MERK79, MERK89] and is the structure of most hash functions in use today, including SHA, which is discussed later in this chapter. The hash function takes an input message and partitions it into L fixed-sized blocks of b bits each. If necessary, the final block is padded to b bits. The final block also includes the value of the total length of the input to the hash function. The inclusion of the length makes the job of the opponent more difficult. Either the opponent must find two messages of equal length that hash to the same value or two messages of differing lengths that, together with their length values, hash to the same value.

The hash algorithm involves repeated use of a **compression function**, f , that takes two inputs (an n -bit input from the previous step, called the *chaining variable*,

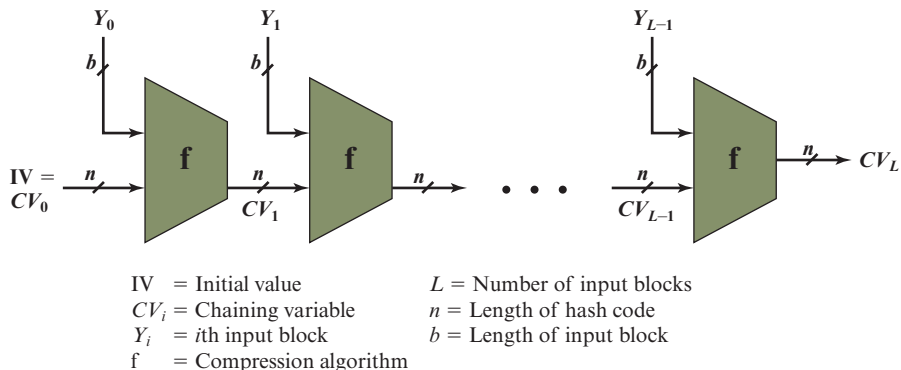

Figure 11.8 General Structure of Secure Hash Code

and a b -bit block) and produces an n -bit output. At the start of hashing, the chaining variable has an initial value that is specified as part of the algorithm. The final value of the chaining variable is the hash value. Often, $b > n$; hence the term *compression*. The hash function can be summarized as

$$\begin{aligned} CV_0 &= IV = \text{initial } n\text{-bit value} \\ CV_i &= f(CV_{i-1}, Y_{i-1}) \quad 1 \leq i \leq L \\ H(M) &= CV_L \end{aligned}$$

where the input to the hash function is a message M consisting of the blocks Y_0, Y_1, \dots, Y_{L-1} .

The motivation for this iterative structure stems from the observation by Merkle [MERK89] and Damgard [DAMG89] that if the length field is included in the input, and if the compression function is collision resistant, then so is the resultant iterated hash function.² Therefore, the structure can be used to produce a secure hash function to operate on a message of any length. The problem of designing a secure hash function reduces to that of designing a collision-resistant compression function that operates on inputs of some fixed size.

Cryptanalysis of hash functions focuses on the internal structure of f and is based on attempts to find efficient techniques for producing collisions for a single execution of f . Once that is done, the attack must take into account the fixed value of IV . The attack on f depends on exploiting its internal structure. Typically, as with symmetric block ciphers, f consists of a series of rounds of processing, so that the attack involves analysis of the pattern of bit changes from round to round.

Keep in mind that for any hash function there must exist collisions, because we are mapping a message of length at least equal to twice the block size b (because we must append a length field) into a hash code of length n , where $b \geq n$. What is required is that it is computationally infeasible to find collisions.

The attacks that have been mounted on hash functions are rather complex and beyond our scope here. For the interested reader, useful surveys of cryptanalysis of hash functions include [PREN10], [ROGA04b], and [LUCK04].

11.4 SECURE HASH ALGORITHM (SHA)

In recent years, the most widely used hash function has been the Secure Hash Algorithm (SHA). Indeed, because virtually every other widely used hash function had been found to have substantial cryptanalytic weaknesses, SHA was more or less the last remaining standardized hash algorithm by 2005. SHA was developed by the National Institute of Standards and Technology (NIST) and published as a federal information processing standard (FIPS 180) in 1993. When weaknesses were discovered in SHA, now known as SHA-0, a revised version was issued as FIPS 180-1 in 1995 and is referred to as SHA-1. The actual standards document is entitled “Secure Hash Standard.” SHA is based on the hash function MD4, and its design closely models MD4.

²The converse is not necessarily true.

Table 11.3 Comparison of SHA Parameters

Algorithm	Message Size	Block Size	Word Size	Message Digest Size
SHA-1	$< 2^{64}$	512	32	160
SHA-224	$< 2^{64}$	512	32	224
SHA-256	$< 2^{64}$	512	32	256
SHA-384	$< 2^{128}$	1024	64	384
SHA-512	$< 2^{128}$	1024	64	512
SHA-512/224	$< 2^{128}$	1024	64	224
SHA-512/256	$< 2^{128}$	1024	64	256

Note: All sizes are measured in bits.

SHA-1 produces a hash value of 160 bits. A simple brute-force technique for “breaking” SHA-1, that is, on being able to produce two different messages that produce the same hash function, would require on average 280 SHA-1 compressions. This appears prohibitive with current and foreseeable computational capacity. However, due to concern that cryptanalytic techniques might soon make SHA-1 vulnerable, NIST published a revised version of the standard in 2002, FIPS 180-2, that defined three new versions of SHA, with hash value lengths of 256, 384, and 512 bits, known as SHA-256, SHA-384, and SHA-512, respectively. Collectively, these hash algorithms are known as SHA-2. These new versions have the same underlying structure and use the same types of modular arithmetic and logical binary operations as SHA-1. A revised document was issued as FIP PUB 180-3 in 2008, which added a 224-bit version (Table 11.3). SHA-1 and SHA-2 are also specified in RFC 6234, which essentially duplicates the material in FIPS 180-3 but adds a C code implementation.

In 2005, NIST announced the intention to phase out approval of SHA-1 and move to a reliance on SHA-2 by 2010. Despite this, SHA-1 continued to be used for digital signature and other applications by numerous applications, such as web browsers. The reluctance to go through the expense and effort of transitioning to SHA-2 has been overcome by a breakthrough announced by a research team in 2017 [STEV17, CONS17]. The team demonstrated that SHA-1 collision attacks have finally become practical by providing the first known instance of a collision. In total, the computational effort spent is equivalent to 263.1 SHA-1 compressions and took approximately 6500 CPU years and 100 GPU years. As a result, Microsoft, Google, Apple, and Mozilla have all announced that their respective browsers have stopped accepting SHA-1 SSL certificates in 2017.

In this section, we provide a description of SHA-512. The other versions are quite similar. [SMIT15] provides a good description of SHA-256.

SHA-512 Logic

The algorithm takes as input a message with a maximum length of less than 2^{128} bits and produces as output a 512-bit message digest. The input is processed in 1024-bit blocks. Figure 11.9 depicts the overall processing of a message to produce a digest. This follows the general structure depicted in Figure 11.8. The processing consists of the following steps.

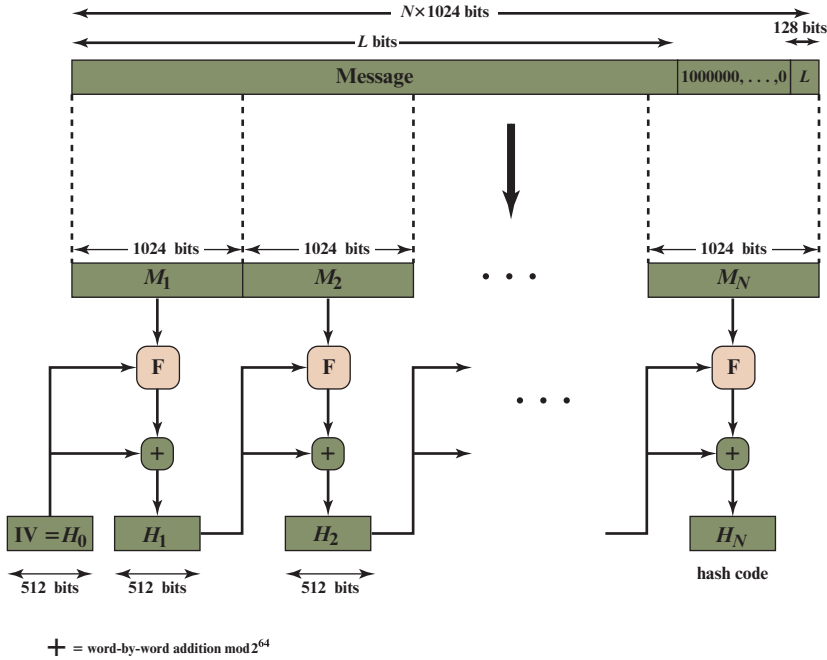

Figure 11.9 Message Digest Generation Using SHA-512

Step 1 Append padding bits. The message is padded so that its length is congruent to 896 modulo 1024 [$\text{length} \equiv 896 \pmod{1024}$]. Padding is always added, even if the message is already of the desired length. Thus, the number of padding bits is in the range of 1 to 1024. The padding consists of a single 1 bit followed by the necessary number of 0 bits.

Step 2 Append length. A block of 128 bits is appended to the message. This block is treated as an unsigned 128-bit integer (most significant byte first) and contains the length of the original message in bits (before the padding).

The outcome of the first two steps yields a message that is an integer multiple of 1024 bits in length. In Figure 11.9, the expanded message is represented as the sequence of 1024-bit blocks M_1, M_2, \dots, M_N , so that the total length of the expanded message is $N \times 1024$ bits.

Step 3 Initialize hash buffer. A 512-bit buffer is used to hold intermediate and final results of the hash function. The buffer can be represented as eight 64-bit registers (a, b, c, d, e, f, g, h). These registers are initialized to the following 64-bit integers (hexadecimal values):

- | | |
|----------------------|----------------------|
| a = 6A09E667F3BCC908 | e = 510E527FADE682D1 |
| b = BB67AE8584CAA73B | f = 9B05688C2B3E6C1F |
| c = 3C6EF372FE94F82B | g = 1F83D9ABFB41BD6B |
| d = A54FF53A5F1D36F1 | h = 5BE0CD19137E2179 |

These words were obtained by taking the first sixty-four bits of the fractional parts of the square roots of the first eight prime numbers. The values are stored in **big-endian format**, which is the most significant byte of a word in the low-address (leftmost) byte position. In contrast, in **little-endian format**, the least significant byte is stored in the lowest address.

Step 4 Process message in 1024-bit (128-byte) blocks. The heart of the algorithm is a module that consists of 80 rounds; this module is labeled F in Figure 11.9. The logic is illustrated in Figure 11.10.

Each round takes as input the 512-bit buffer value, $abcdefgh$, and updates the contents of the buffer. At input to the first round, the buffer has the value of the intermediate hash value, H_{i-1} . Each round t makes use of a 64-bit value W_t , derived from the current 1024-bit block being processed (M_i). These values are derived using a message schedule described subsequently. Each round also makes use of an additive constant K_t , where $0 \leq t \leq 79$ indicates one of the 80 rounds. These words represent the first 64 bits of the fractional parts of the cube roots of the first 80 prime numbers. The constants provide a “randomized” set of 64-bit patterns, which should eliminate any regularities in the input data. Table 11.4 shows these constants in hexadecimal format (from left to right).

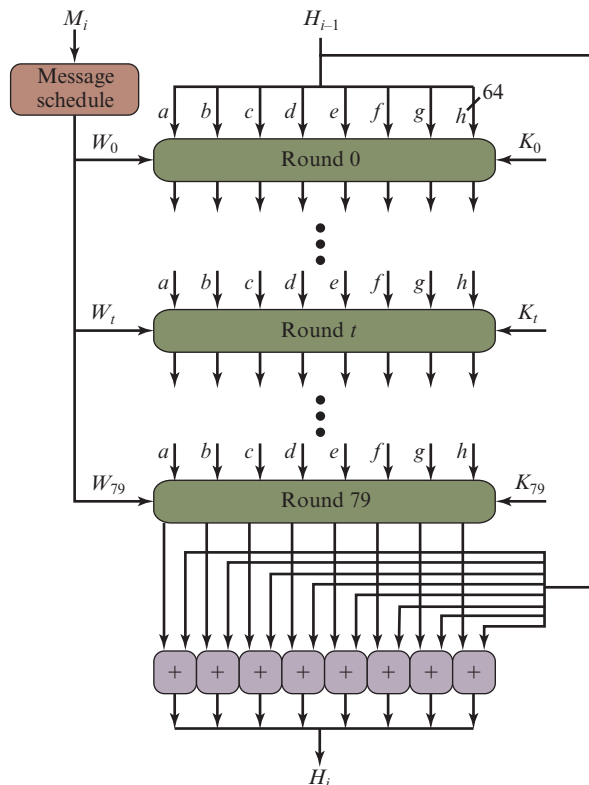

Figure 11.10 SHA-512 Processing of a Single 1024-Bit Block

Table 11.4 SHA-512 Constants

428a2f98d728ae22	7137449123ef65cd	b5c0fbcfec4d3b2f	e9b5dba58189dbbc
3956c25bf348b538	59f111f1b605d019	923f82a4af194f9b	ab1c5ed5da6d8118
d807aa98a3030242	12835b0145706fbe	243185be4ee4b28c	550c7dc3d5ffb4e2
72be5d74f27b896f	80deb1fe3b1696b1	9bdc06a725c71235	c19bf174cf692694
e49b69c19ef14ad2	efbe4786384f25e3	0fc19dc68b8cd5b5	240ca1cc77ac9c65
2de92c6f592b0275	4a7484aa6ea6e483	5cb0a9dcbbd41fbd4	76f988da831153b5
983e5152ee66dfab	a831c66d2db43210	b00327c898fb213f	bf597fc7beef0ee4
c6e00bf33da88fc2	d5a79147930aa725	06ca6351e003826f	142929670a0e6e70
27b70a8546d22ffc	2e1b21385c26c926	4d2c6dffc5ac42aed	53380d139d95b3df
650a73548baf63de	766a0abb3c77b2a8	81c2c92e47edaee6	92722c851482353b
a2bfe8a14cf10364	a81a664bbc423001	c24b8b70d0f89791	c76c51a30654be30
d192e819d6ef5218	d69906245565a910	f40e35855771202a	106aa07032bbd1b8
19a4c116b8d2d0c8	1e376c085141ab53	2748774cdf8eeb99	34b0bcb5e19b48a8
391c0cb3c5c95a63	4ed8aa4ae3418acb	5b9cca4f7763e373	682e6ff3d6b2b8a3
748f82ee5defb2fc	78a5636f43172f60	84c87814a1f0ab72	8cc702081a6439ec
90bfffafa23631e28	a4506cebde82bde9	bef9a3f7b2c67915	c67178f2e372532b
ca273eceeaa26619c	d186b8c721c0c207	eada7dd6cde0eb1e	f57d4f7fee6ed178
06f067aa72176fba	0a637dc5a2c898a6	113f9804bef90dae	1b710b35131c471b
28db77f523047d84	32caab7b40c72493	3c9ebe0a15c9bebc	431d67c49c100d4c
4cc5d4becb3e42b6	597f299cfc657e2a	5fcb6fab3ad6faec	6c44198c4a475817

The output of the eightieth round is added to the input to the first round (H_{i-1}) to produce H_i . The addition is done independently for each of the eight words in the buffer with each of the corresponding words in H_{i-1} , using addition modulo 2^{64} .

Step 5 Output. After all N 1024-bit blocks have been processed, the output from the N th stage is the 512-bit message digest.

We can summarize the behavior of SHA-512 as follows:

$$\begin{aligned} H_0 &= IV \\ H_i &= \text{SUM}_{64}(H_{i-1}, abcdefgh_i) \\ MD &= H_N \end{aligned}$$

where

- IV = initial value of the abcdefgh buffer, defined in step 3
- $abcdefgh_i$ = the output of the last round of processing of the i th message block
- N = the number of blocks in the message (including padding and length fields)
- SUM_{64} = addition modulo 2^{64} performed separately on each word of the pair of inputs
- MD = final message digest value

SHA-512 Round Function

Let us look in more detail at the logic in each of the 80 steps of the processing of one 512-bit block (Figure 11.11). Each round is defined by the following set of equations:

$$\begin{aligned}
 T_1 &= h + \text{Ch}(e, f, g) + (\sum_1^{512} e) + W_t + K_t \\
 T_2 &= (\sum_0^{512} a) + \text{Maj}(a, b, c) \\
 h &= g \\
 g &= f \\
 f &= e \\
 e &= d + T_1 \\
 d &= c \\
 c &= b \\
 b &= a \\
 a &= T_1 + T_2
 \end{aligned}$$

where

- t = step number; $0 \leq t \leq 79$
- $\text{Ch}(e, f, g) = (e \text{ AND } f) \oplus (\text{NOT } e \text{ AND } g)$
the conditional function: If e then f else g
- $\text{Maj}(a, b, c) = (a \text{ AND } b) \oplus (a \text{ AND } c) \oplus (b \text{ AND } c)$
the function is true only of the majority (two or three) of the arguments are true
- $(\sum_0^{512} a) = \text{ROTR}^{28}(a) \oplus \text{ROTR}^{34}(a) \oplus \text{ROTR}^{39}(a)$
- $(\sum_1^{512} e) = \text{ROTR}^{14}(e) \oplus \text{ROTR}^{18}(e) \oplus \text{ROTR}^{41}(e)$
- $\text{ROTR}^n(x) =$ circular right shift (rotation) of the 64-bit argument x by n bits

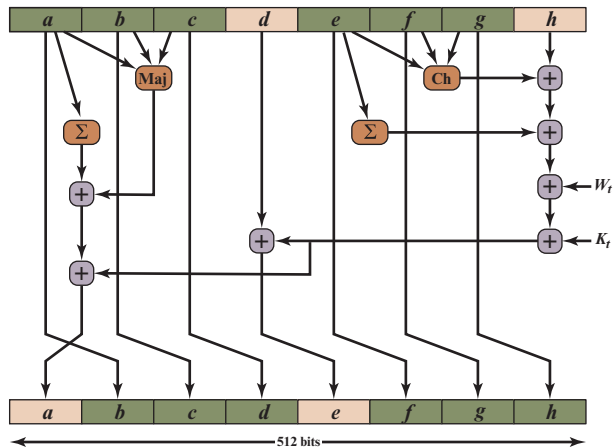

Figure 11.11 Elementary SHA-512 Operation (single round)

W_t = a 64-bit word derived from the current 1024-bit input block

K_t = a 64-bit additive constant

+ = addition modulo 2^{64}

Two observations can be made about the round function.

1. Six of the eight words of the output of the round function involve simply permutation (b, c, d, f, g, h) by means of rotation. This is indicated by shading in Figure 11.11.
2. Only two of the output words (a, e) are generated by substitution. Word e is a function of input variables (d, e, f, g, h), as well as the round word W_t and the constant K_t . Word a is a function of all of the input variables except d , as well as the round word W_t and the constant K_t .

It remains to indicate how the 64-bit word values W_t are derived from the 1024-bit message. Figure 11.12 illustrates the mapping. The first 16 values of W_t are taken directly from the 16 words of the current block. The remaining values are defined as

$$W_t = \sigma_1^{512}(W_{t-2}) + W_{t-7} + \sigma_0^{512}(W_{t-15}) + W_{t-16}$$

where

$$\sigma_0^{512}(x) = \text{ROTR}^1(x) \oplus \text{ROTR}^8(x) \oplus \text{SHR}^7(x)$$

$$\sigma_1^{512}(x) = \text{ROTR}^{19}(x) \oplus \text{ROTR}^{61}(x) \oplus \text{SHR}^6(x)$$

$\text{ROTR}^n(x)$ = circular right shift (rotation) of the 64-bit argument x by n bits

$\text{SHR}^n(x)$ = right shift of the 64-bit argument x by n bits with padding by zeros on the left

+ = addition modulo 2^{64}

Thus, in the first 16 steps of processing, the value of W_t is equal to the corresponding word in the message block. For the remaining 64 steps, the value of W_t consists of the circular left shift by one bit of the XOR of four of the preceding values of W_t , with two of those values subjected to shift and rotate operations.

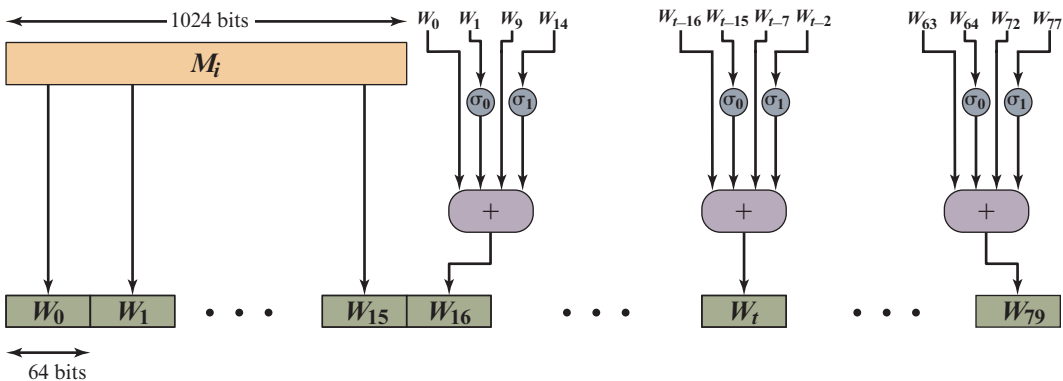

Figure 11.12 Creation of 80-word Input Sequence for SHA-512 Processing of Single Block

This introduces a great deal of redundancy and interdependence into the message blocks that are compressed, which complicates the task of finding a different message block that maps to the same compression function output. Figure 11.13 summarizes the SHA-512 logic.

The SHA-512 algorithm has the property that every bit of the hash code is a function of every bit of the input. The complex repetition of the basic function F produces results that are well mixed; that is, it is unlikely that two messages chosen at random, even if they exhibit similar regularities, will have the same hash code. Unless there is some undisclosed weakness in SHA-512 the difficulty of coming up with two messages having the same message digest is on the order of 2^{256} operations, while the difficulty of finding a message with a given digest is on the order of 2^{512} operations.

Example

We include here an example based on one in FIPS 180. We wish to hash a one-block message consisting of three ASCII characters: “abc,” which is equivalent to the following 24-bit binary string:

```
01100001 01100010 01100011
```

Recall from step 1 of the SHA algorithm, that the message is padded to a length congruent to 896 modulo 1024. In this case of a single block, the padding consists of $896 - 24 = 872$ bits, consisting of a “1” bit followed by 871 “0” bits. Then a 128-bit length value is appended to the message, which contains the length of the original message in bits (before the padding). The original length is 24 bits, or a hexadecimal value of 18. Putting this all together, the 1024-bit message block, in hexadecimal, is

```
6162638000000000 0000000000000000 0000000000000000 0000000000000000
0000000000000000 0000000000000000 0000000000000000 0000000000000000
0000000000000000 0000000000000000 0000000000000000 0000000000000000
0000000000000000 0000000000000000 0000000000000000 0000000000000018
```

This block is assigned to the words W_0, \dots, W_{15} of the message schedule, which appears as follows.

$W_0 = 6162638000000000$	$W_8 = 0000000000000000$
$W_1 = 0000000000000000$	$W_9 = 0000000000000000$
$W_2 = 0000000000000000$	$W_{10} = 0000000000000000$
$W_3 = 0000000000000000$	$W_{11} = 0000000000000000$
$W_4 = 0000000000000000$	$W_{12} = 0000000000000000$
$W_5 = 0000000000000000$	$W_{13} = 0000000000000000$
$W_6 = 0000000000000000$	$W_{14} = 0000000000000000$
$W_7 = 0000000000000000$	$W_{15} = 0000000000000018$

The padded message consists blocks M_1, M_2, \dots, M_N . Each message block M_i consists of 16 64-bit words $M_{i,0}, M_{i,1}, \dots, M_{i,15}$. All addition is performed modulo 2^{64} .

$$\begin{array}{ll} H_{0,0} = 6A09E667F3BCC908 & H_{0,4} = 510E527FADE682D1 \\ H_{0,1} = BB67AE8584CAA73B & H_{0,5} = 9B05688C2B3E6C1F \\ H_{0,2} = 3C6EF372FE94F82B & H_{0,6} = 1F83D9ABFB41BD6B \\ H_{0,3} = A54FF53A5F1D36F1 & H_{0,7} = 5BE0CD19137E2179 \end{array}$$

for $i = 1$ **to** N

1. Prepare the message schedule W

for $t = 0$ **to** 15

$$W_t = M_{i,t}$$

for $t = 16$ **to** 79

$$W_t = \sigma_1^{512}(W_{t-2}) + W_{t-7} + \sigma_0^{512}(W_{t-15}) + W_{t-16}$$

2. Initialize the working variables

$$a = H_{i-1,0} \quad e = H_{i-1,4}$$

$$b = H_{i-1,1} \quad f = H_{i-1,5}$$

$$c = H_{i-1,2} \quad g = H_{i-1,6}$$

$$d = H_{i-1,3} \quad h = H_{i-1,7}$$

3. Perform the main hash computation

for $t = 0$ **to** 79

$$T_1 = h + \text{Ch}(e, f, g) + \left(\Sigma_1^{512} e \right) + W_t + K_t$$

$$T_2 = \left(\Sigma_0^{512} a \right) + \text{Maj}(a, b, c)$$

$$h = g$$

$$g = f$$

$$f = e$$

$$e = d + T_1$$

$$d = c$$

$$c = b$$

$$b = a$$

$$a = T_1 + T_2$$

4. Compute the intermediate hash value

$$H_{i,0} = a + H_{i-1,0} \quad H_{i,4} = e + H_{i-1,4}$$

$$H_{i,1} = b + H_{i-1,1} \quad H_{i,5} = f + H_{i-1,5}$$

$$H_{i,2} = c + H_{i-1,2} \quad H_{i,6} = g + H_{i-1,6}$$

$$H_{i,3} = d + H_{i-1,3} \quad H_{i,7} = h + H_{i-1,7}$$

return $\{H_{N,0} \| H_{N,1} \| H_{N,2} \| H_{N,3} \| H_{N,4} \| H_{N,5} \| H_{N,6} \| H_{N,7}\}$

Figure 11.13 SHA-512 Logic

As indicated in Figure 11.13, the eight 64-bit variables, a through h , are initialized to values $H_{0,0}$ through $H_{0,7}$. The following table shows the initial values of these variables and their values after each of the first two rounds.

a	6a09e667f3bcc908	f6afceb8bcfcddf5	1320f8c9fb872cc0
b	bb67ae8584caa73b	6a09e667f3bcc908	f6afceb8bcfcddf5
c	3c6ef372fe94f82b	bb67ae8584caa73b	6a09e667f3bcc908
d	a54ff53a5f1d36f1	3c6ef372fe94f82b	bb67ae8584caa73b
e	510e527fade682d1	58cb02347ab51f91	c3d4ebfd48650ffa
f	9b05688c2b3e6c1f	510e527fade682d1	58cb02347ab51f91
g	1f83d9abfb41bd6b	9b05688c2b3e6c1f	510e527fade682d1
h	5be0cd19137e2179	1f83d9abfb41bd6b	9b05688c2b3e6c1f

Note that in each of the rounds, six of the variables are copied directly from variables from the preceding round.

The process continues through 80 rounds. The output of the final round is

```
73a54f399fa4b1b2 10d9c4c4295599f6 d67806db8b148677 654ef9abec389ca9
d08446aa79693ed7 9bb4d39778c07f9e 25c96a7768fb2aa3 ceb9fc3691ce8326
```

The hash value is then calculated as

$$\begin{aligned}
 H_{1,0} &= 6a09e667f3bcc908 + 73a54f399fa4b1b2 = ddaf35a193617aba \\
 H_{1,1} &= bb67ae8584caa73b + 10d9c4c4295599f6 = cc417349ae204131 \\
 H_{1,2} &= 3c6ef372fe94f82b + d67806db8b148677 = 12e6fa4e89a97ea2 \\
 H_{1,3} &= a54ff53a5f1d36f1 + 654ef9abec389ca9 = 0a9eeee64b55d39a \\
 H_{1,4} &= 510e527fade682d1 + d08446aa79693ed7 = 2192992a274fc1a8 \\
 H_{1,5} &= 9b05688c2b3e6c1f + 9bb4d39778c07f9e = 36ba3c23a3feebbd \\
 H_{1,6} &= 1f83d9abfb41bd6b + 25c96a7768fb2aa3 = 454d4423643ce80e \\
 H_{1,7} &= 5be0cd19137e2179 + ceb9fc3691ce8326 = 2a9ac94fa54ca49f
 \end{aligned}$$

The resulting 512-bit message digest is

```
ddaf35a193617aba cc417349ae204131 12e6fa4e89a97ea2 0a9eeee64b55d39a
2192992a274fc1a8 36ba3c23a3feebbd 454d4423643ce80e 2a9ac94fa54ca49f
```

Suppose now that we change the input message by one bit, from “abc” to “cbc.” Then, the 1024-bit message block is

```
6362638000000000 0000000000000000 0000000000000000 0000000000000000
0000000000000000 0000000000000000 0000000000000000 0000000000000000
0000000000000000 0000000000000000 0000000000000000 0000000000000000
0000000000000000 0000000000000000 0000000000000000 0000000000000018
```

And the resulting 512-bit message digest is

```
531668966ee79b70 0b8e593261101354 4273f7ef7b31f279 2a7ef68d53f93264
319c165ad96d9187 55e6a204c2607e27 6e05cdf993a64c85 ef9e1e125c0f925f
```

The number of bit positions that differ between the two hash values is 253, almost exactly half the bit positions, indicating that SHA-512 has a good avalanche effect.

11.5 SHA-3

As of this writing, the Secure Hash Algorithm (SHA-1) has not yet been “broken.” That is, no one has demonstrated a technique for producing collisions in a practical amount of time. However, because SHA-1 is very similar, in structure and in the basic mathematical operations used, to MD5 and SHA-0, both of which have been broken, SHA-1 is considered insecure and has been phased out for SHA-2.

SHA-2, particularly the 512-bit version, would appear to provide unassailable security. However, SHA-2 shares the same structure and mathematical operations as its predecessors, and this is a cause for concern. Because it will take years to find a suitable replacement for SHA-2, should it become vulnerable, NIST decided to begin the process of developing a new hash standard.

Accordingly, NIST announced in 2007 a competition to produce the next generation NIST hash function, to be called SHA-3. The winning design for SHA-3 was announced by NIST in October 2012 and published as FIP 102 in August 2015. SHA-3 is a cryptographic hash function that is intended to complement SHA-2 as the approved standard for a wide range of applications.

NISTIR 7896 (*Third-Round Report of the SHA-3 Cryptographic Hash Algorithm Competition*) summarizes the evaluation criteria used by NIST to select from among the candidates for SHA-3, plus the rationale for picking Keccak, which was the winning candidate. This material is useful in understanding not just the SHA-3 design but also the criteria by which to judge any cryptographic hash algorithm.

The Sponge Construction

The underlying structure of SHA-3 is a scheme referred to by its designers as a sponge construction [BERT07, BERT11]. The sponge construction has the same general structure as other iterated hash functions (Figure 11.8). The sponge function takes an input message and partitions it into fixed-size blocks. Each block is processed in turn with the output of each iteration fed into the next iteration, finally producing an output block.

The sponge function is defined by three parameters:

f = the internal function used to process each input block³

r = the size in bits of the input blocks, called the bitrate

pad = the padding algorithm

A sponge function allows both variable length input and output, making it a flexible structure that can be used for a hash function (fixed-length output), a pseudorandom number generator (fixed-length input), and other cryptographic functions. Figure 11.14 illustrates this point. An input message of n bits is partitioned into k fixed-size blocks of r bits each. The message is padded to achieve a length that is an integer multiple of r bits. The resulting partition is the sequence of blocks P_0, P_1, \dots, P_{k-1} , with length $k \times r$. For uniformity, padding is always added, so

³The Keccak documentation refers to f as a permutation. As we shall see, it involves both permutations and substitutions. We refer to f as the **iteration function**, because it is the function that is executed once for each iteration, that is, once for each block of the message that is processed.

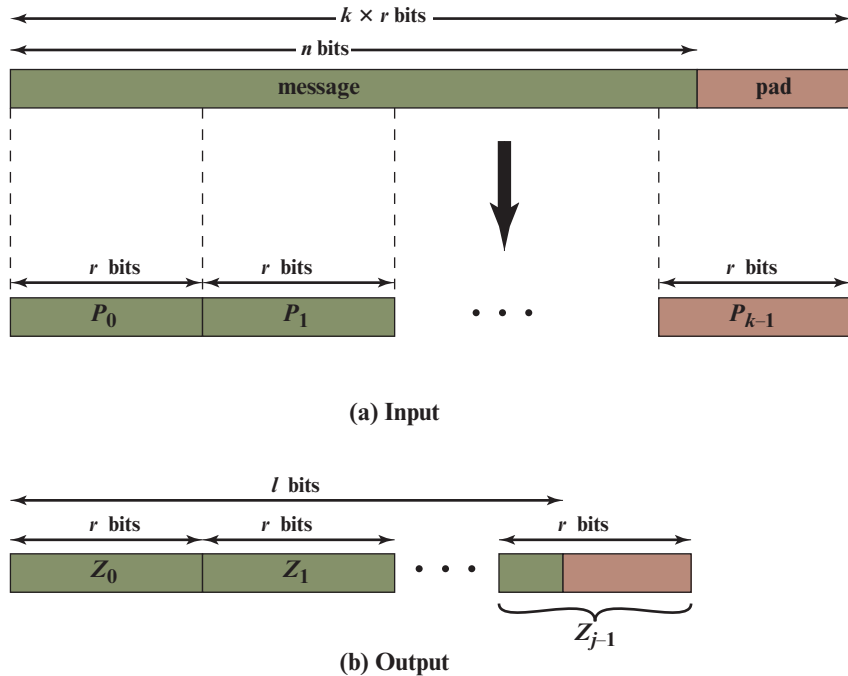

Figure 11.14 Sponge Function Input and Output

that if $n \bmod r = 0$, a padding block of r bits is added. The actual padding algorithm is a parameter of the function. The sponge specification proposes two padding schemes. The following definitions are based on [BERT11]

- **Simple padding (pad10*):** The minimum padding is added so that the block length divides the padded message length. The padding is all zeros except the first padding bit is a binary one.
- **Multirate padding (pad10*1):** The minimum padding is added so that the block length divides the padded message length. The padding is all zeros except the first and last padding bit are binary ones. Unlike simple padding, multirate padding is secure even if the rate r is changed for a given f . FIPS 202 uses multirate padding.

After processing all of the blocks, the sponge function generates a sequence of output blocks Z_0, Z_1, \dots, Z_{j-1} . The number of output blocks generated is determined by the number of output bits desired. If the desired output is ℓ bits, then j blocks are produced, such that $(j - 1) \times r < \ell \leq j \times r$.

Figure 11.15 shows the iterated structure of the sponge function. The sponge construction operates on a state variable s of $b = r + c$ bits, which is initialized to all zeros and modified at each iteration. The value r is called the bitrate. This value is the block size used to partition the input message. The term *bitrate* reflects the fact that r is the number of bits processed at each iteration: the larger the value of r , the greater the rate at which message bits are processed by the sponge construction.

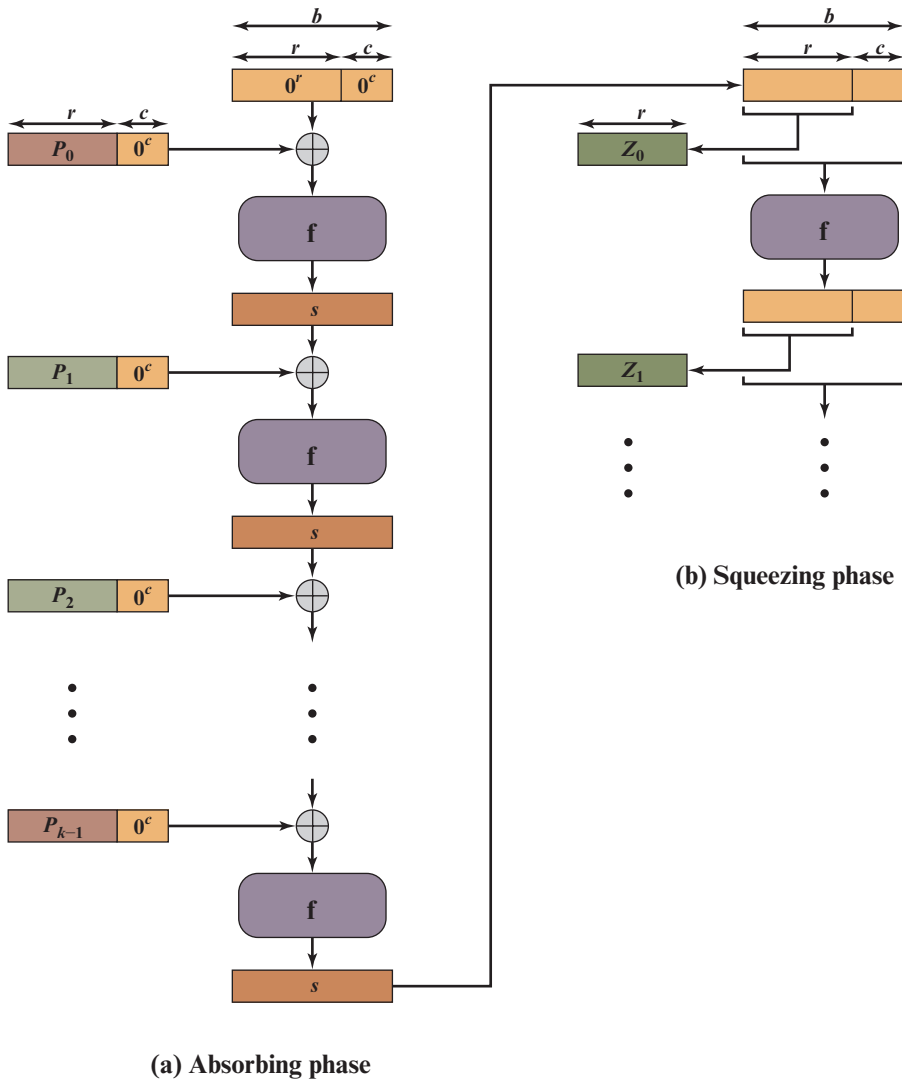

Figure 11.15 Sponge Construction

The value c is referred to as the capacity. A discussion of the security implications of the capacity is beyond our scope. In essence, the capacity is a measure of the achievable complexity of the sponge construction and therefore the achievable level of security. A given implementation can increase claimed security and reduce speed by increasing the capacity c and decreasing the bitrate r accordingly, or vice versa. The default values for Keccak are $c = 1024$ bits, $r = 576$ bits, and therefore $b = 1600$ bits.

The sponge construction consists of two phases. The absorbing phase proceeds as follows: For each iteration, the input block to be processed is padded with zeroes to extend its length from r bits to b bits. Then, the bitwise XOR of the extended

message block and s is formed to create a b -bit input to the iteration function f . The output of f is the value of s for the next iteration.

If the desired output length ℓ satisfies $\ell \leq b$, then at the completion of the absorbing phase, the first r bits of s are returned and the sponge construction terminates. Otherwise, the sponge construction enters the squeezing phase. To begin, the first r bits of s are retained as block Z_0 . Then, the value of s is updated with repeated executions of f , and at each iteration, the first r bits of s are retained as block Z_i and concatenated with previously generated blocks. The process continues through $(j - 1)$ iterations until we have $(j - 1) \times r < \ell \leq j \times r$. At this point the first ℓ bits of the concatenated block Z are returned.

Note that the absorbing phase has the structure of a typical hash function. A common case will be one in which the desired hash length is less than or equal to the input block length; that is, $\ell \leq r$. In that case, the sponge construction terminates after the absorbing phase. If a longer output than b bits is required, then the squeezing phase is employed. Thus the sponge construction is quite flexible. For example, a short message with a length r could be used as a seed and the sponge construction would function as a pseudorandom number generator.

To summarize, the sponge construction is a simple iterated construction for building a function F with variable-length input and arbitrary output length based on a fixed-length transformation or permutation f operating on a fixed number b of bits. The sponge construction is defined formally in [BERT11] as follows:

```

Algorithm The sponge construction SPONGE[ $f$ , pad,  $r$ ]
Require:  $r < b$ 

  Interface:  $Z = \text{sponge}(M, \ell)$  with  $M \in \mathbf{Z}_2^*$ , integer  $\ell > 0$  and  $Z \in \mathbf{Z}_2^\ell$ 
   $P = M \parallel \text{pad}[r] \ (|M|)$ 
   $s = 0^b$ 
  for  $i = 0$  to  $|P|_r - 1$  do
     $s = s \oplus (Pi \parallel 0^{b-r})$ 
     $s = f(s)$ 
  end for
   $Z = \lfloor s \rfloor_r$ 
  while  $|Z|_r \ r < \ell$  do
     $s = f(s)$ 
     $Z = Z \parallel \lfloor s \rfloor_r$ 
  end while
  return  $\lfloor Z \rfloor_\ell$ 

```

In the algorithm definition, the following notation is used: $|M|$ is the length in bits of a bit string M . A bit string M can be considered as a sequence of blocks of some fixed length x , where the last block may be shorter. The number of blocks of M is denoted by $|M|_x$. The blocks of M are denoted by M_i and the index ranges from 0 to $|M|_x - 1$. The expression $\lfloor M \rfloor_\ell$ denotes the truncation of M to its first ℓ bits.

Table 11.5 SHA-3 Parameters

Message Digest Size	224	256	384	512
Message Size	no maximum	no maximum	no maximum	no maximum
Block Size (bitrate r)	1152	1088	832	576
Word Size	64	64	64	64
Number of Rounds	24	24	24	24
Capacity c	448	512	768	1024
Collision Resistance	2^{112}	2^{128}	2^{192}	2^{256}
Second Preimage Resistance	2^{224}	2^{256}	2^{384}	2^{512}

Note: All sizes and security levels—are measured in bits.

SHA-3 makes use of the iteration function f , labeled Keccak- f , which is described in the next section. The overall SHA-3 function is a sponge function expressed as Keccak[r, c] to reflect that SHA-3 has two operational parameters, r , the message block size, and c , the capacity, with the default of $r + c = 1600$ bits. Table 11.5 shows the supported values of r and c . As Table 11.5 shows, the hash function security associated with the sponge construction is a function of the capacity c .

In terms of the sponge algorithm defined above, Keccak[r, c] is defined as

$$\text{Keccak}[r, c] \triangleq \text{SPONGE}[\text{Keccak-}f[r + c], \text{pad } 10^*1, r]$$

We now turn to a discussion of the iteration function Keccak- f .

The SHA-3 Iteration Function f

We now examine the iteration function Keccak- f used to process each successive block of the input message. Recall that f takes as input a 1600-bit variable s consisting of r bits, corresponding to the message block size followed by c bits, referred to as the capacity. For internal processing within f , the input state variable s is organized as a $5 \times 5 \times 64$ array a . The 64-bit units are referred to as lanes. For our purposes, we generally use the notation $a[x, y, z]$ to refer to an individual bit with in the state array. When we are more concerned with operations that affect entire lanes, we designate the 5×5 matrix as $L[x, y]$, where each entry in L is a 64-bit lane. The use of indices within this matrix is shown in Figure 11.16.⁴ Thus, the columns are labeled $x = 0$ through $x = 4$, the rows are labeled $y = 0$ through $y = 4$, and the individual bits within a lane are labeled $z = 0$ through $z = 63$. The mapping between the bits of s and those of a is

$$s[64(5y + x) + z] = a[x, y, z]$$

⁴Note that the first index (x) designates a column and the second index (y) designates a row. This is in conflict with the convention used in most mathematics sources, where the first index designates a row and the second index designates a column (e.g., Knuth, D. *The Art of Computing Programming, Volume 1, Fundamental Algorithms*; and Korn, G., and Korn, T. *Mathematical Handbook for Scientists and Engineers*).

	$x = 0$	$x = 1$	$x = 2$	$x = 3$	$x = 4$
$y = 4$	$L[0, 4]$	$L[1, 4]$	$L[2, 4]$	$L[3, 4]$	$L[4, 4]$
$y = 3$	$L[0, 3]$	$L[1, 3]$	$L[2, 3]$	$L[3, 3]$	$L[4, 3]$
$y = 2$	$L[0, 2]$	$L[1, 2]$	$L[2, 2]$	$L[3, 2]$	$L[4, 2]$
$y = 1$	$L[0, 1]$	$L[1, 1]$	$L[2, 1]$	$L[4, 1]$	$L[4, 1]$
$y = 0$	$L[0, 0]$	$L[1, 0]$	$L[2, 0]$	$L[3, 0]$	$L[4, 0]$

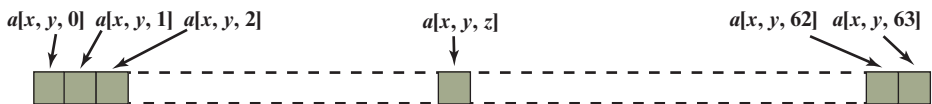
(a) State variable as 5×5 matrix A of 64-bit words

(b) Bit labeling of 64-bit words

Figure 11.16 SHA-3 State Matrix

We can visualize this with respect to the matrix in Figure 11.16. When treating the state as a matrix of lanes, the first lane in the lower left corner, $L[0, 0]$, corresponds to the first 64 bits of s . The lane in the second column, lowest row, $L[1, 0]$, corresponds to the next 64 bits of s . Thus, the array a is filled with the bits of s starting with row $y = 0$ and proceeding row by row.

STRUCTURE OF f The function f is executed once for each input block of the message to be hashed. The function takes as input the 1600-bit state variable and converts it into a 5×5 matrix of 64-bit lanes. This matrix then passes through 24 rounds of processing. Each round consists of five steps, and each step updates the state matrix by permutation or substitution operations. As shown in Figure 11.17, the rounds are identical with the exception of the final step in each round, which is modified by a round constant that differs for each round.

The application of the five steps can be expressed as the composition⁵ of functions:

$$R = i \circ \chi \circ \pi \circ \rho \circ \theta$$

Table 11.6 summarizes the operation of the five steps. The steps have a simple description leading to a specification that is compact and in which no trapdoor can be hidden. The operations on lanes in the specification are limited to bitwise Boolean operations (XOR, AND, NOT) and rotations. There is no need for table lookups, arithmetic operations, or data-dependent rotations. Thus, SHA-3 is easily and efficiently implemented in either hardware or software.

We examine each of the step functions in turn.

⁵If f and g are two functions, then the function F with the equation $y = F(x) = g[f(x)]$ is called the **composition** of f and g and is denoted as $F = g \circ f$.

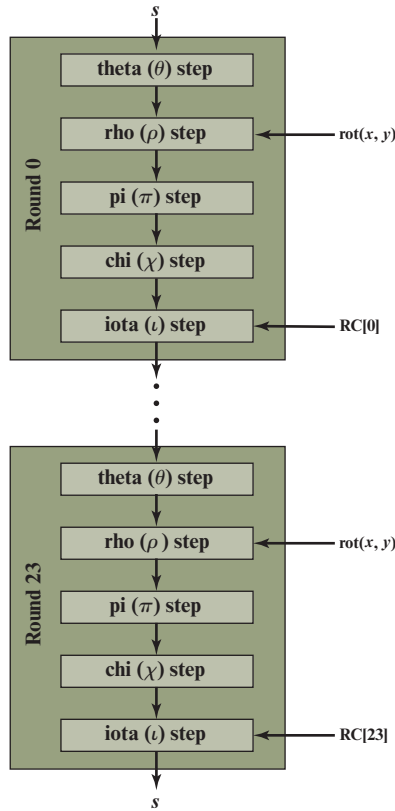

Figure 11.17 SHA-3 Iteration Function f

Table 11.6 Step Functions in SHA-3

Function	Type	Description
θ	Substitution	New value of each bit in each word depends on its current value and on one bit in each word of preceding column and one bit of each word in succeeding column.
ρ	Permutation	The bits of each word are permuted using a circular bit shift. $W[0, 0]$ is not affected.
π	Permutation	Words are permuted in the 5×5 matrix. $W[0, 0]$ is not affected.
χ	Substitution	New value of each bit in each word depends on its current value and on one bit in next word in the same row and one bit in the second next word in the same row.
ι	Substitution	$W[0, 0]$ is updated by XOR with a round constant.

THETA STEP FUNCTION The Keccak reference defines the θ function as follows. For bit z in column x , row y ,

$$\theta: a[x, y, z] \leftarrow a[x, y, z] \oplus \sum_{y'=0}^4 a[(x - 1), y', z] \oplus \sum_{y'=0}^4 a[(x + 1), y', (z - 1)] \quad (11.1)$$

where the summations are XOR operations. We can see more clearly what this operation accomplishes with reference to Figure 11.18a. First, define the bitwise XOR of the lanes in column x as

$$C[x] = L[x, 0] \oplus L[x, 1] \oplus L[x, 2] \oplus L[x, 3] \oplus L[x, 4]$$

Consider lane $L[x, y]$ in column x , row y . The first summation in Equation 11.1 performs a bitwise XOR of the lanes in column $(x - 1) \bmod 4$ to form the 64-bit lane $C[x - 1]$. The second summation performs a bitwise XOR of the lanes in column $(x + 1) \bmod 4$, and then rotates the bits within the 64-bit lane so that the bit in position z is mapped into position $z + 1 \bmod 64$. This forms the lane $\text{ROT}(C[x + 1], 1)$. These two lanes and $L[x, y]$ are combined by bitwise XOR to form the updated value of $L[x, y]$. This can be expressed as

$$L[x, y] \leftarrow L[x, y] \oplus C[x - 1] \oplus \text{ROT}(C[x + 1], 1)$$

Figure 11.18.a illustrates the operation on $L[3, 2]$. The same operation is performed on all of the other lanes in the matrix.

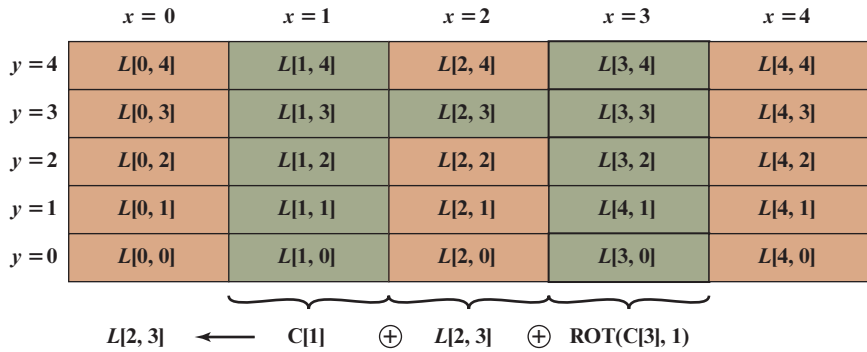

(a) θ step function

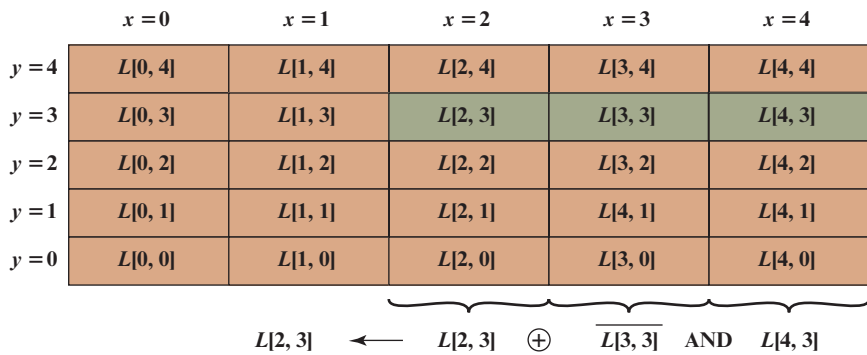

(b) χ step function

Figure 11.18 Theta and Chi Step Functions

Several observations are in order. Each bit in a lane is updated using the bit itself and one bit in the same bit position from each lane in the preceding column and one bit in the adjacent bit position from each lane in the succeeding column. Thus the updated value of each bit depends on 11 bits. This provides good mixing. Also, the theta step provides good diffusion, as that term was defined in Chapter 4. The designers of Keccak state that the theta step provides a high level of diffusion on average and that without theta, the round function would not provide diffusion of any significance.

RHO STEP FUNCTION The ρ function is defined as follows:

$$\rho: a[x, y, z] \leftarrow a[x, y, z] \quad \text{if } x = y = 0$$

otherwise,

$$\rho: a[x, y, z] \leftarrow a\left[x, y, \left(z - \frac{(t+1)(t+2)}{2}\right)\right] \quad (11.2)$$

with t satisfying $0 \leq t < 24$ and $\begin{pmatrix} 0 & 1 \\ 2 & 3 \end{pmatrix}^t \begin{pmatrix} 1 \\ 0 \end{pmatrix} = \begin{pmatrix} x \\ y \end{pmatrix}$ in $\text{GF}(5)^{2 \times 2}$

It is not immediately obvious what this step performs, so let us look at the process in detail.

1. The lane in position $(x, y) = (0, 0)$, that is $L[0, 0]$, is unaffected. For all other words, a circular bit shift within the lane is performed.
2. The variable t , with $0 \leq t < 24$, is used to determine both the amount of the circular bit shift and which lane is assigned which shift value.
3. The 24 individual bit shifts that are performed have the respective values

$$\frac{(t+1)(t+2)}{2} \bmod 64.$$

4. The shift determined by the value of t is performed on the lane in position (x, y) in the 5×5 matrix of lanes. Specifically, for each value of t , the corresponding matrix position is defined by $\begin{pmatrix} x \\ y \end{pmatrix} = \begin{pmatrix} 0 & 1 \\ 2 & 3 \end{pmatrix}^t \begin{pmatrix} 1 \\ 0 \end{pmatrix}$. For example, for

$t = 3$, we have

$$\begin{aligned} \begin{pmatrix} x \\ y \end{pmatrix} &= \begin{pmatrix} 0 & 1 \\ 2 & 3 \end{pmatrix}^3 \begin{pmatrix} 1 \\ 0 \end{pmatrix} \bmod 5 \\ &= \begin{pmatrix} 0 & 1 \\ 2 & 3 \end{pmatrix} \begin{pmatrix} 0 & 1 \\ 2 & 3 \end{pmatrix} \begin{pmatrix} 0 & 1 \\ 2 & 3 \end{pmatrix} \begin{pmatrix} 1 \\ 0 \end{pmatrix} \bmod 5 \\ &= \begin{pmatrix} 0 & 1 \\ 2 & 3 \end{pmatrix} \begin{pmatrix} 0 & 1 \\ 2 & 3 \end{pmatrix} \begin{pmatrix} 0 \\ 2 \end{pmatrix} \bmod 5 \\ &= \begin{pmatrix} 0 & 1 \\ 2 & 3 \end{pmatrix} \begin{pmatrix} 2 \\ 6 \end{pmatrix} \bmod 5 = \begin{pmatrix} 0 & 1 \\ 2 & 3 \end{pmatrix} \begin{pmatrix} 2 \\ 1 \end{pmatrix} \bmod 5 \\ &= \begin{pmatrix} 1 \\ 7 \end{pmatrix} \bmod 5 = \begin{pmatrix} 1 \\ 2 \end{pmatrix} \end{aligned}$$

Table 11.7 Rotation Values Used in SHA-3

(a) Calculation of values and positions

t	$g(t)$	$g(t) \bmod 64$	x, y
0	1	1	1,0
1	3	3	0,2
2	6	6	2,1
3	10	10	1,2
4	15	15	2,3
5	21	21	3,3
6	28	28	3,0
7	36	36	0,1
8	45	45	1,3
9	55	55	3,1
10	66	2	1,4
11	78	14	4,4

t	$g(t)$	$g(t) \bmod 64$	x, y
12	91	27	4,0
13	105	41	0,3
14	120	56	3,4
15	136	8	4,3
16	153	25	3,2
17	171	43	2,2
18	190	62	2,0
19	210	18	0,4
20	231	39	4,2
21	253	61	2,4
22	276	20	4,1
23	300	44	1,1

Note: $g(t) = (t + 1)(t + 2)/2$

$$\begin{pmatrix} x \\ y \end{pmatrix} = \begin{pmatrix} 0 & 1 \\ 2 & 3 \end{pmatrix}^t \begin{pmatrix} 1 \\ 0 \end{pmatrix} \bmod 5$$

(b) Rotation values by word position in matrix

	$x = 0$	$x = 1$	$x = 2$	$x = 3$	$x = 4$
$y = 4$	18	2	61	56	14
$y = 3$	41	45	15	21	8
$y = 2$	3	10	43	25	39
$y = 1$	36	44	6	55	20
$y = 0$	0	1	62	28	27

Table 11.7 shows the calculations that are performed to determine the amount of the bit shift and the location of each bit shift value. Note that all of the rotation amounts are different.

The ρ function thus consists of a simple permutation (circular shift) within each lane. The intent is to provide diffusion within each lane. Without this function, diffusion between lanes would be very slow.

PI STEP FUNCTION The π function is defined as follows:

$$\pi: a[x, y] \leftarrow a[x', y'], \quad \text{with} \begin{pmatrix} x \\ y \end{pmatrix} = \begin{pmatrix} 0 & 1 \\ 2 & 3 \end{pmatrix} \begin{pmatrix} x' \\ y' \end{pmatrix} \quad (11.3)$$

This can be rewritten as $(x, y) \times (y, (2x + 3y))$. Thus, the lanes within the 5×5 matrix are moved so that the new x position equals the old y position and

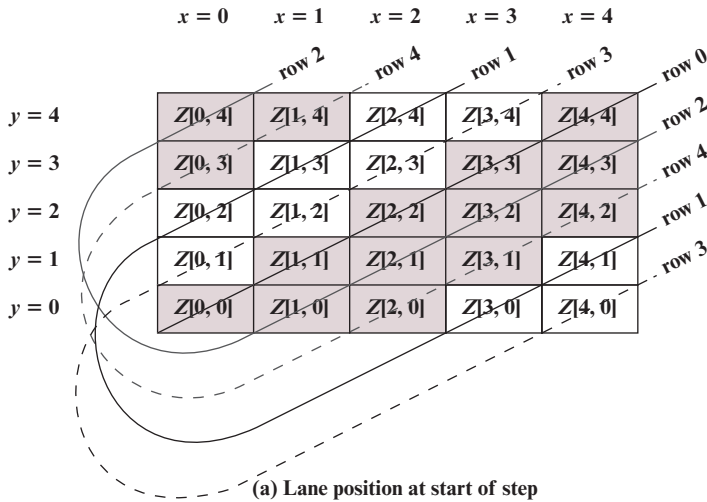

	x = 0	x = 1	x = 2	x = 3	x = 4
y = 4	Z[2, 0]	Z[3, 1]	Z[4, 2]	Z[0, 3]	Z[1, 4]
y = 3	Z[4, 0]	Z[0, 1]	Z[1, 2]	Z[2, 3]	Z[3, 4]
y = 2	Z[1, 0]	Z[2, 1]	Z[3, 2]	Z[4, 3]	Z[0, 4]
y = 1	Z[3, 0]	Z[4, 1]	Z[0, 2]	Z[1, 3]	Z[2, 4]
y = 0	Z[0, 0]	Z[1, 1]	Z[2, 2]	Z[3, 3]	Z[4, 4]

(b) Lane position after permutation

Figure 11.19 Pi Step Function

the new y position is determined by $(2x + 3y) \bmod 5$. Figure 11.19 helps in visualizing this permutation. Lanes that are along the same diagonal (increasing in y value, going from left to right) prior to π are arranged on the same row in the matrix after π is executed. Note that the position of $L[0, 0]$ is unchanged.

Thus the π step is a permutation of lanes: The lanes move position within the 5×5 matrix. The ρ step is a permutation of bits: Bits within a lane are rotated. Note that the π step matrix positions are calculated in the same way that, for the ρ step, the one-dimensional sequence of rotation constants is mapped to the lanes of the matrix.

CHI STEP FUNCTION The χ function is defined as follows:

$$\chi: a[x] \leftarrow a[x] \oplus ((a[x + 1] \oplus 1) \text{ AND } a[x + 2]) \tag{11.4}$$

This function operates to update each bit based on its current value and the value of the corresponding bit position in the next two lanes in the same row. The

operation is more clearly seen if we consider a single bit $a[x, y, z]$ and write out the Boolean expression:

$$a[x, y, z] \leftarrow a[x, y, z] \oplus (\text{NOT}(a[x + 1, y, z])) \text{ AND } (a[x + 2, y, z])$$

Figure 11.18b illustrates the operation of the χ function on the bits of the lane $L[3, 2]$. This is the only one of the step functions that is a nonlinear mapping. Without it, the SHA-3 round function would be linear.

IOTA STEP FUNCTION The ι function is defined as follows:

$$\iota: a \leftarrow a \oplus \text{RC}[i_r] \quad (11.5)$$

This function combines an array element with a round constant that differs for each round. It breaks up any symmetry induced by the other four step functions. In fact, Equation 11.5 is somewhat misleading. The round constant is applied only to the first lane of the internal state array. We express this as follows:

$$L[0, 0] \leftarrow L[0, 0] \oplus \text{RC}[i_r] \quad 0 \leq i_r \leq 23$$

Table 11.8 lists the 24 64-bit round constants. Note that the Hamming weight, or number of 1 bits, in the round constants ranges from 1 to 6. Most of the bit positions are zero and thus do not change the corresponding bits in $L[0, 0]$. If we take the cumulative OR of all 24 round constants, we get

$$\text{RC}[0] \text{ OR } \text{RC}[1] \text{ OR } \dots \text{ OR } \text{RC}[23] = 800000008000808\text{B}$$

Thus, only 7 bit positions are active and can affect the value of $L[0, 0]$. Of course, from round to round, the permutations and substitutions propagate the effects of the ι function to all of the lanes and all of the bit positions in the matrix. It is easily seen that the disruption diffuses through θ and χ to all lanes of the state after a single round.

Table 11.8 Round Constants in SHA-3

Round	Constant (hexadecimal)	Number of 1 bits	Round	Constant (hexadecimal)	Number of 1 bits
0	0000000000000001	1	12	00000008000808B	6
1	0000000000008082	3	13	80000000000008B	5
2	800000000000808A	5	14	8000000000008089	5
3	800000080008000	3	15	800000000008003	4
4	00000000000808B	5	16	800000000008002	3
5	000000080000001	2	17	800000000000080	2
6	800000080008081	5	18	00000000000800A	3
7	800000000008009	4	19	80000008000000A	4
8	00000000000008A	3	20	800000080008081	5
9	000000000000088	2	21	800000000008080	3
10	000000080008009	4	22	000000080000001	2
11	00000008000000A	3	23	800000080008008	4

11.6 KEY TERMS, REVIEW QUESTIONS, AND PROBLEMS

Key Terms

big endian compression function cryptographic hash function	hash code hash function hash value little endian	message authentication code (MAC) message digest
--	---	--

Review Questions

- 11.1 What characteristics are needed in a secure hash function?
- 11.2 Alice sends Bob a message with an attached hash value. If the message digest is sent in a secure fashion, then how would Bob know if there was a possible man-in-the-middle attack?
- 11.3 What is the role of a compression function in a hash function?
- 11.4 How safe is it to use a hash function without encryption in terms of integrity?
- 11.5 What basic arithmetical and logical functions are used in SHA?
- 11.6 Define a collision and explain how to deal with collision attacks.
- 11.7 Define the term *sponge construction*.
- 11.8 Summarise the five main steps of SHA-512 and its main functions.
- 11.9 List and briefly describe the step functions that comprise the iteration function f .

Problems

- 11.1 The high-speed transport protocol XTP (Xpress Transfer Protocol) uses a 32-bit checksum function defined as the concatenation of two 16-bit functions: XOR and RXOR, defined in Section 11.4 as “two simple hash functions” and illustrated in Figure 11.5.
 - a. Will this checksum detect all errors caused by an odd number of error bits? Explain.
 - b. Will this checksum detect all errors caused by an even number of error bits? If not, characterize the error patterns that will cause the checksum to fail.
 - c. Comment on the effectiveness of this function for use as a hash function for authentication.
- 11.2 a. A number of proposals have been made for hash functions based on using a cipher block chaining technique but without using the secret key. One example, proposed in [DAVI89], is as follows. Divide a message M into fixed-size blocks M_1, M_2, \dots, M_N and use a symmetric encryption system such as DES to compute the hash code H as

$$\begin{aligned}
 H_0 &= \text{initial value} \\
 H_i &= H_{i-1} \oplus E(M_i, H_{i-1}) \\
 H &= H_N
 \end{aligned}$$

Assume that DES is used as the encryption algorithm. Recall the complementarity property of DES (Problem 4.14): If $Y = E(K, X)$, then $Y' = E(K', X')$. Use this property to show how a message consisting of blocks M_1, M_2, \dots, M_N can be altered without altering its hash code.

- b. A variation of the scheme above is proposed in [MEYE88], with the following formula:

$$H_i = M_i \oplus E(H_{i-1}, M_i)$$

Show that a similar attack that of Problem 11.2a will succeed against this scheme.

- 11.3 a.** Consider the following hash function. Messages are in the form of a sequence of numbers in Z_n , $M = (a_1, a_2, \dots, a_t)$. The hash value h is calculated as $\left(\sum_{i=1}^t a_i\right)$ for some predefined value n . Does this hash function satisfy any of the requirements for a hash function listed in Table 11.1? Explain your answer.
- b.** Repeat part (a) for the hash function $h = \left(\sum_{i=1}^t (a_i)^2\right) \bmod n$.
- c.** Calculate the hash function of part (b) for $M = (189, 632, 900, 722, 349)$ and $n = 989$.
- 11.4** For a message digest where hash functions are used to provide message authentication and integrity, what is the most appropriate way to protect the hash values?
- 11.5** Encryption assists in providing confidentiality to the data being sent from party A to party B. However, in recent years, there is an interest in avoiding encryption depending on the application. Why?
- 11.6** Suppose $H(m)$ is a collision-resistant hash function that maps a message of arbitrary bit length into an n -bit hash value. Is it true that, for all messages x, x' with $x \neq x'$, we have $H(x) \neq H(x')$ Explain your answer.
- 11.7** Given the rotation values used in SHA-3 in Table 11.7, if $x = 3$ and $y = 2$, how many bit shifts are necessary for a rotation and how random can this operation be?
- 11.8** For SHA-512, show the equations for the values of W_{16} , W_{18} , W_{23} , and W_{31} .
- 11.9** State the value of the padding field in SHA-512 if the length of the message is
- 2942 bits.
 - 2943 bits.
 - 2944 bits.
- 11.10** State the value of the length field in SHA-512 if the length of the message is
- 2942 bits.
 - 2943 bits.
 - 2944 bits.
- 11.11** Suppose $a_1 a_2 a_3 a_4$ are the 4 bytes in a 32-bit word. Each a_i can be viewed as an integer in the range 0 to 255, represented in binary. In a big-endian architecture, this word represents the integer

$$a_1 2^{24} + a_2 2^{16} + a_3 2^8 + a_4$$

In a little-endian architecture, this word represents the integer

$$a_4 2^{24} + a_3 2^{16} + a_2 2^8 + a_1$$

- a.** Some hash functions, such as MD5, assume a little-endian architecture. It is important that the message digest be independent of the underlying architecture. Therefore, to perform the modulo 2 addition operation of MD5 or RIPEMD-160 on a big-endian architecture, an adjustment must be made. Suppose $X = x_1 x_2 x_3 x_4$ and $Y = y_1 y_2 y_3 y_4$. Show how the MD5 addition operation $(X + Y)$ would be carried out on a big-endian machine.
- b.** SHA assumes a big-endian architecture. Show how the operation $(X + Y)$ for SHA would be carried out on a little-endian machine.

11.12 This problem introduces a hash function similar in spirit to SHA that operates on letters instead of binary data. It is called the *toy tetragraph hash* (tth).⁶ Given a message consisting of a sequence of letters, tth produces a hash value consisting of four letters. First, tth divides the message into blocks of 16 letters, ignoring spaces, punctuation, and capitalization. If the message length is not divisible by 16, it is padded out with nulls. A four-number running total is maintained that starts out with the value (0, 0, 0, 0); this is input to the compression function for processing the first block. The compression function consists of two rounds.

Round 1 Get the next block of text and arrange it as a row-wise 4×4 block of text, and convert it to numbers ($A = 0, B = 1$, etc.). For example, for the block ABCDEFGHIJKLMNOP, we have

A	B	C	D
E	F	G	H
I	J	K	L
M	N	O	P

0	1	2	3
4	5	6	7
8	9	10	11
12	13	14	15

Then, add each column mod 26 and add the result to the running total, mod 26. In this example, the running total is (24, 2, 6, 10).

Round 2 Using the matrix from round 1, rotate the first row left by 1, second row left by 2, third row left by 3, and reverse the order of the fourth row. In our example:

B	C	D	A
G	H	E	F
L	I	J	K
P	O	N	M

1	2	3	0
6	7	4	5
11	8	9	10
15	14	13	12

Now, add each column mod 26 and add the result to the running total. The new running total is (5, 7, 9, 11). This running total is now the input into the first round of the compression function for the next block of text. After the final block is processed, convert the final running total to letters. For example, if the message is ABCDEFGHIJKLMNOP, then the hash is FHJL.

- a. Draw figures comparable to Figures 11.9 and 11.10 to depict the overall tth logic and the compression function logic.
 - b. Calculate the hash function for the 22-letter message “Practice makes us perfect.”
 - c. To demonstrate the weakness of tth, find a message of length 32-letter that produces the same hash.
- 11.13** For each of the possible capacity values of SHA-3 (Table 11.5), which lanes in the internal 55 state matrix start out as lanes of all zeros?
- 11.14** During the permutation phase in SHA-3, if a new position is determined by $(2x + 3y) \bmod 5$, how big is the matrix in the permutation of lanes? Illustrate your answer with the aid of a diagram.

⁶I thank William K. Mason, of the magazine staff of *The Cryptogram*, for providing this example.

- 11.15** Consider the state matrix as illustrated in Figure 11.16a. Now rearrange the rows and columns of the matrix so that $L[0, 0]$ is in the center. Specifically, arrange the columns in the left-to-right order ($x = 3, x = 4, x = 0, x = 1, x = 2$) and arrange the rows in the top-to-bottom order ($y = 2, y = 1, y = 0, y = 4, y = 6$). This should give you some insight into the permutation algorithm used for the function and for permuting the rotation constants in the function. Using this rearranged matrix, describe the permutation algorithm.
- 11.16** The function only affects $L[0, 0]$. Section 11.6 states that the changes to $L[0, 0]$ diffuse through θ and to all lanes of the state after a single round.
- Show that this is so.
 - How long before all of the bit positions in the matrix are affected by the changes to $L[0, 0]$?

CHAPTER 12

MESSAGE AUTHENTICATION CODES

12.1 Message Authentication Requirements

12.2 Message Authentication Functions

- Message Encryption
- Message Authentication Code

12.3 Requirements for Message Authentication Codes

12.4 Security of MACs

- Brute-Force Attacks
- Cryptanalysis

12.5 MACs Based on Hash Functions: HMAC

- HMAC Design Objectives
- HMAC Algorithm
- Security of HMAC

12.6 MACs Based on Block Ciphers: DAA and CMAC

- Data Authentication Algorithm
- Cipher-Based Message Authentication Code (CMAC)

12.7 Authenticated Encryption: CCM and GCM

- Counter with Cipher Block Chaining-Message Authentication Code
- Galois/Counter Mode

12.8 Key Wrapping

- Background
- The Key Wrapping Algorithm
- Key Unwrapping

12.9 Pseudorandom Number Generation Using Hash Functions and MACs

- PRNG Based on Hash Function
- PRNG Based on MAC Function

12.10 Key Terms, Review Questions, and Problems

LEARNING OBJECTIVES

After studying this chapter, you should be able to:

- ◆ List and explain the possible attacks that are relevant to message authentication.
- ◆ Define the term *message authentication code*.
- ◆ List and explain the requirements for a message authentication code.
- ◆ Present an overview of HMAC.
- ◆ Present an overview of CMAC.
- ◆ Explain the concept of authenticated encryption.
- ◆ Present an overview of CCM.
- ◆ Present an overview of GCM.
- ◆ Discuss the concept of key wrapping and explain its use.
- ◆ Understand how a hash function or a message authentication code can be used for pseudorandom number generation.

One of the most fascinating and complex areas of cryptography is that of message authentication and the related area of digital signatures. It would be impossible, in anything less than book length, to exhaust all the cryptographic functions and protocols that have been proposed or implemented for message authentication and digital signatures. Instead, the purpose of this chapter and the next is to provide a broad overview of the subject and to develop a systematic means of describing the various approaches.

This chapter begins with an introduction to the requirements for authentication and digital signature and the types of attacks to be countered. Then the basic approaches are surveyed. The remainder of the chapter deals with the fundamental approach to message authentication known as the message authentication code (MAC). Following an overview of this topic, the chapter looks at security considerations for MACs. This is followed by a discussion of specific MACs in two categories: those built from cryptographic hash functions and those built using a block cipher mode of operation. Next, we look at a relatively recent approach known as authenticated encryption. Finally, we look at the use of cryptographic hash functions and MACs for pseudorandom number generation.

12.1 MESSAGE AUTHENTICATION REQUIREMENTS

In the context of communications across a network, the following attacks can be identified.

1. **Disclosure:** Release of message contents to any person or process not possessing the appropriate cryptographic key.

2. **Traffic analysis:** Discovery of the pattern of traffic between parties. In a connection-oriented application, the frequency and duration of connections could be determined. In either a connection-oriented or connectionless environment, the number and length of messages between parties could be determined.
3. **Masquerade:** Insertion of messages into the network from a fraudulent source. This includes the creation of messages by an opponent that are purported to come from an authorized entity. Also included are fraudulent acknowledgments of message receipt or nonreceipt by someone other than the message recipient.
4. **Content modification:** Changes to the contents of a message, including insertion, deletion, transposition, and modification.
5. **Sequence modification:** Any modification to a sequence of messages between parties, including insertion, deletion, and reordering.
6. **Timing modification:** Delay or replay of messages. In a connection-oriented application, an entire session or sequence of messages could be a replay of some previous valid session, or individual messages in the sequence could be delayed or replayed. In a connectionless application, an individual message (e.g., datagram) could be delayed or replayed.
7. **Source repudiation:** Denial of transmission of message by source.
8. **Destination repudiation:** Denial of receipt of message by destination.

Measures to deal with the first two attacks are in the realm of message confidentiality and are dealt with in Part One. Measures to deal with items (3) through (6) in the foregoing list are generally regarded as message authentication. Mechanisms for dealing specifically with item (7) come under the heading of digital signatures. Generally, a digital signature technique will also counter some or all of the attacks listed under items (3) through (6). Dealing with item (8) may require a combination of the use of digital signatures and a protocol designed to counter this attack.

In summary, **message authentication** is a procedure to verify that received messages come from the alleged source and have not been altered. Message authentication may also verify sequencing and timeliness. A digital signature is an authentication technique that also includes measures to counter repudiation by the source.

12.2 MESSAGE AUTHENTICATION FUNCTIONS

Any message authentication or digital signature mechanism has two levels of functionality. At the lower level, there must be some sort of function that produces an **authenticator**: a value to be used to authenticate a message. This lower-level function is then used as a primitive in a higher-level authentication protocol that enables a receiver to verify the authenticity of a message.

This section is concerned with the types of functions that may be used to produce an authenticator. These may be grouped into three classes.

- **Hash function:** A function that maps a message of any length into a fixed-length hash value, which serves as the authenticator
- **Message encryption:** The ciphertext of the entire message serves as its authenticator
- **Message authentication code (MAC):** A function of the message and a secret key that produces a fixed-length value that serves as the authenticator

Hash functions, and how they may serve for message authentication, are discussed in Chapter 11. The remainder of this section briefly examines the remaining two topics. The remainder of the chapter elaborates on the topic of MACs.

Message Encryption

Message encryption by itself can provide a measure of authentication. The analysis differs for symmetric and public-key encryption schemes.

SYMMETRIC ENCRYPTION Consider the straightforward use of symmetric encryption (Figure 12.1a). A message M transmitted from source A to destination B is encrypted using a secret key K shared by A and B. If no other party knows the key, then confidentiality is provided: No other party can recover the plaintext of the message.

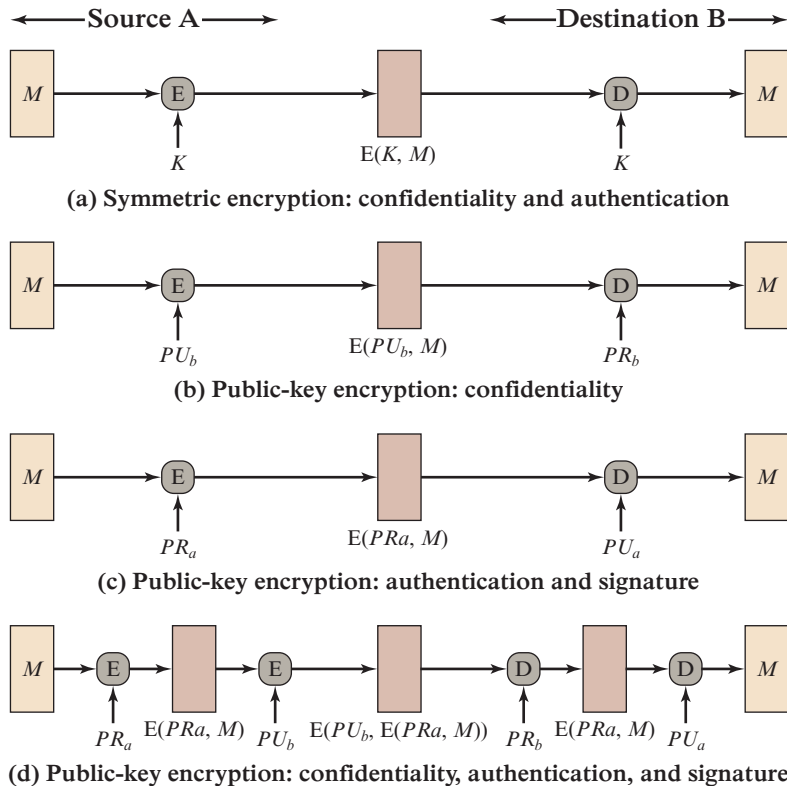

Figure 12.1 Basic Uses of Message Encryption

In addition, B is assured that the message was generated by A. Why? The message must have come from A, because A is the only other party that possesses K and therefore the only other party with the information necessary to construct ciphertext that can be decrypted with K . Furthermore, if M is recovered, B knows that none of the bits of M have been altered, because an opponent that does not know K would not know how to alter bits in the ciphertext to produce the desired changes in the plaintext.

So we may say that symmetric encryption provides authentication as well as confidentiality. However, this flat statement needs to be qualified. Consider exactly what is happening at B. Given a decryption function D and a secret key K , the destination will accept *any* input X and produce output $Y = D(K, X)$. If X is the ciphertext of a legitimate message M produced by the corresponding encryption function, then Y is some plaintext message M . Otherwise, Y will likely be a meaningless sequence of bits. There may need to be some automated means of determining at B whether Y is legitimate plaintext and therefore must have come from A.

The implications of the line of reasoning in the preceding paragraph are profound from the point of view of authentication. Suppose the message M can be any arbitrary bit pattern. In that case, there is no way to determine automatically, at the destination, whether an incoming message is the ciphertext of a legitimate message. This conclusion is incontrovertible: If M can be any bit pattern, then regardless of the value of X , the value $Y = D(K, X)$ is *some* bit pattern and therefore must be accepted as authentic plaintext.

Thus, in general, we require that only a small subset of all possible bit patterns be considered legitimate plaintext. In that case, any spurious ciphertext is unlikely to produce legitimate plaintext. For example, suppose that only one bit pattern in 10^6 is legitimate plaintext. Then the probability that any randomly chosen bit pattern, treated as ciphertext, will produce a legitimate plaintext message is only 10^{-6} .

For a number of applications and encryption schemes, the desired conditions prevail as a matter of course. For example, suppose that we are transmitting English-language messages using a Caesar cipher with a shift of one ($K = 1$). A sends the following legitimate ciphertext:

```
nbsftfbupbutboeepftfbupbutboemjuumfmbnctfbujwz
```

B decrypts to produce the following plaintext:

```
mareseatoatsanddoeseatoatsandlittlelambseativy
```

A simple frequency analysis confirms that this message has the profile of ordinary English. On the other hand, if an opponent generates the following random sequence of letters:

```
zuvrsoevgqxzlzwigamdvnmhpccxiuureosfbcebtqxsxq
```

this decrypts to

```
ytuqrndufpwkyvhfzlcumlgolbbwhttqdnreabdasprwp
```

which does not fit the profile of ordinary English.

It may be difficult to determine *automatically* if incoming ciphertext decrypts to intelligible plaintext. If the plaintext is, say, a binary object file or digitized X-rays, determination of properly formed and therefore authentic plaintext may be difficult. Thus, an opponent could achieve a certain level of disruption simply by issuing messages with random content purporting to come from a legitimate user.

One solution to this problem is to force the plaintext to have some structure that is easily recognized but that cannot be replicated without recourse to the encryption function. We could, for example, append an error-detecting code, also known as a frame check sequence (FCS) or checksum, to each message before encryption, as illustrated in Figure 12.2a. A prepares a plaintext message M and then provides this as input to a function F that produces an FCS. The FCS is appended to M and the entire block is then encrypted. At the destination, B decrypts the incoming block and treats the results as a message with an appended FCS. B applies the same function F to attempt to reproduce the FCS. If the calculated FCS is equal to the incoming FCS, then the message is considered authentic. It is unlikely that any random sequence of bits would exhibit the desired relationship.

Note that the order in which the FCS and encryption functions are performed is critical. The sequence illustrated in Figure 12.2a is referred to in [DIFF79] as **internal error control**, which the authors contrast with **external error control** (Figure 12.2b). With internal error control, authentication is provided because an opponent would have difficulty generating ciphertext that, when decrypted, would have valid error control bits. If instead the FCS is the outer code, an opponent can construct messages with valid error-control codes. Although the opponent cannot know what the decrypted plaintext will be, he or she can still hope to create confusion and disrupt operations.

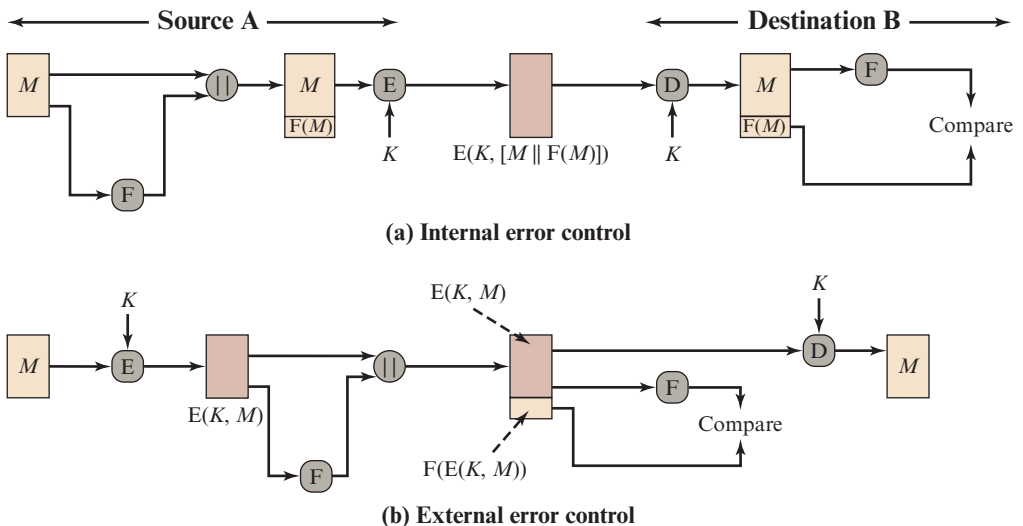

Figure 12.2 Internal and External Error Control

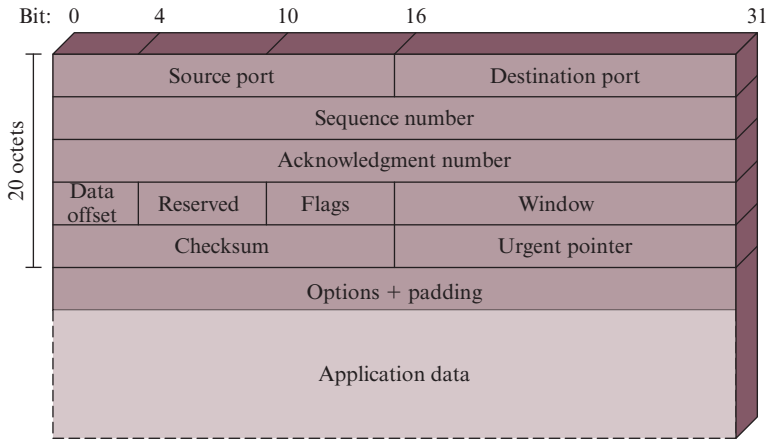

Figure 12.3 TCP Segment

An error-control code is just one example; in fact, any sort of structuring added to the transmitted message serves to strengthen the authentication capability. Such structure is provided by the use of a communications architecture consisting of layered protocols. As an example, consider the structure of messages transmitted using the TCP/IP protocol architecture. Figure 12.3 shows the format of a TCP segment, illustrating the TCP header. Now suppose that each pair of hosts shared a unique secret key, so that all exchanges between a pair of hosts used the same key, regardless of application. Then we could simply encrypt all of the datagram except the IP header. Again, if an opponent substituted some arbitrary bit pattern for the encrypted TCP segment, the resulting plaintext would not include a meaningful header. In this case, the header includes not only a checksum (which covers the header) but also other useful information, such as the sequence number. Because successive TCP segments on a given connection are numbered sequentially, encryption assures that an opponent does not delay, misorder, or delete any segments.

PUBLIC-KEY ENCRYPTION The straightforward use of public-key encryption (Figure 12.1b) provides confidentiality but not authentication. The source (A) uses the public key PU_b of the destination (B) to encrypt M . Because only B has the corresponding private key PR_b , only B can decrypt the message. This scheme provides no authentication, because any opponent could also use B's public key to encrypt a message and claim to be A.

To provide authentication, A uses its private key to encrypt the message, and B uses A's public key to decrypt (Figure 12.1c). This provides authentication using the same type of reasoning as in the symmetric encryption case: The message must have come from A because A is the only party that possesses PR_a and therefore the only party with the information necessary to construct ciphertext that can be decrypted with PU_a . Again, the same reasoning as before applies: There must be some internal structure to the plaintext so that the receiver can distinguish between well-formed plaintext and random bits.

Assuming there is such structure, then the scheme of Figure 12.1c does provide authentication. It also provides what is known as digital signature.¹ Only A could have constructed the ciphertext because only A possesses PR_A . Not even B, the recipient, could have constructed the ciphertext. Therefore, if B is in possession of the ciphertext, B has the means to prove that the message must have come from A. In effect, A has “signed” the message by using its private key to encrypt. Note that this scheme does not provide confidentiality. Anyone in possession of A’s public key can decrypt the ciphertext.

To provide both confidentiality and authentication, A can encrypt M first using its private key, which provides the digital signature, and then using B’s public key, which provides confidentiality (Figure 12.1d). The disadvantage of this approach is that the public-key algorithm, which is complex, must be exercised four times rather than two in each communication.

Message Authentication Code

An alternative authentication technique involves the use of a secret key to generate a small fixed-size block of data, known as a **cryptographic checksum** or MAC, that is appended to the message. This technique assumes that two communicating parties, say A and B, share a common secret key K . When A has a message to send to B, it calculates the MAC as a function of the message and the key:

$$\text{MAC} = C(K, M)$$

where

- M = input message
- C = MAC function
- K = shared secret key
- MAC = message authentication code

The message plus MAC are transmitted to the intended recipient. The recipient performs the same calculation on the received message, using the same secret key, to generate a new MAC. The received MAC is compared to the calculated MAC (Figure 12.4a). If we assume that only the receiver and the sender know the identity of the secret key, and if the received MAC matches the calculated MAC, then

1. The receiver is assured that the message has not been altered. If an attacker alters the message but does not alter the MAC, then the receiver’s calculation of the MAC will differ from the received MAC. Because the attacker is assumed not to know the secret key, the attacker cannot alter the MAC to correspond to the alterations in the message.
2. The receiver is assured that the message is from the alleged sender. Because no one else knows the secret key, no one else could prepare a message with a proper MAC.

¹This is not the way in which digital signatures are constructed, as we shall see, but the principle is the same.

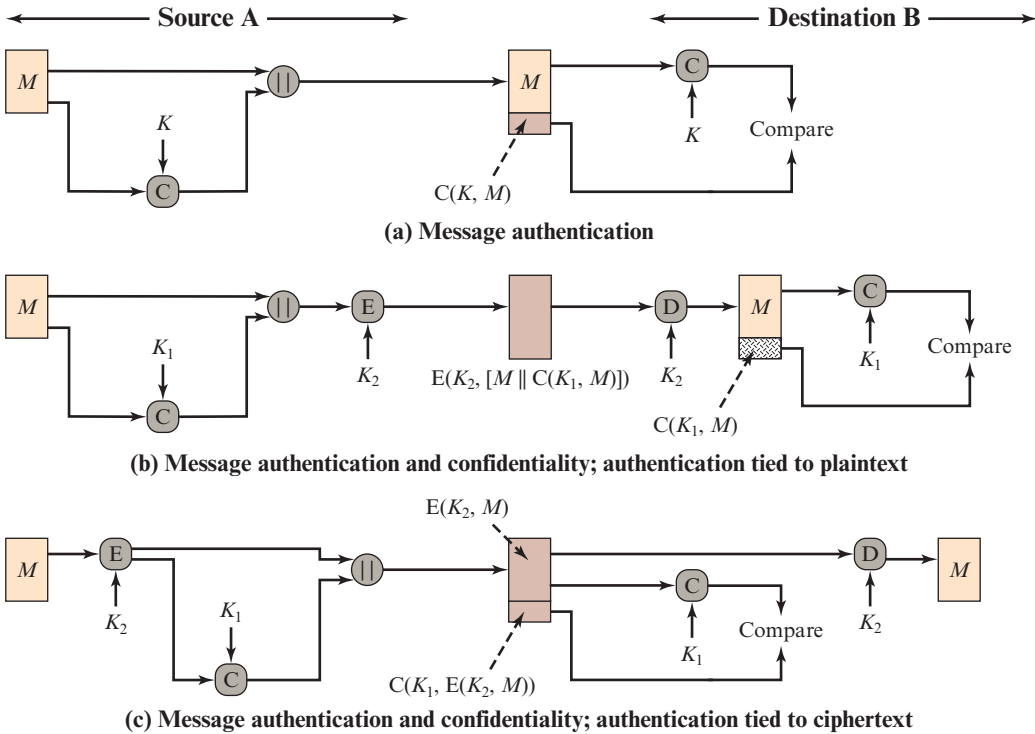

Figure 12.4 Basic Uses of Message Authentication code (MAC)

3. If the message includes a sequence number (such as is used with HDLC, X.25, and TCP), then the receiver can be assured of the proper sequence because an attacker cannot successfully alter the sequence number.

A MAC function is similar to encryption. One difference is that the MAC algorithm need not be reversible, as it must be for decryption. In general, the MAC function is a many-to-one function. The domain of the function consists of messages of some arbitrary length, whereas the range consists of all possible MACs and all possible keys. If an n -bit MAC is used, then there are 2^n possible MACs, whereas there are N possible messages with $N \gg 2^n$. Furthermore, with a k -bit key, there are 2^k possible keys.

For example, suppose that we are using 100-bit messages and a 10-bit MAC. Then, there are a total of 2^{100} different messages but only 2^{10} different MACs. So, on average, each MAC value is generated by a total of $2^{100}/2^{10} = 2^{90}$ different messages. If a 5-bit key is used, then there are $2^5 = 32$ different mappings from the set of messages to the set of MAC values.

It turns out that, because of the mathematical properties of the authentication function, it is less vulnerable to being broken than encryption.

The process depicted in Figure 12.4a provides authentication but not confidentiality, because the message as a whole is transmitted in the clear. Confidentiality can be provided by performing message encryption either after (Figure 12.4b) or before (Figure 12.4c) the MAC algorithm. In both these cases, two separate keys are needed,

each of which is shared by the sender and the receiver. In the first case, the MAC is calculated with the message as input and is then concatenated to the message. The entire block is then encrypted. In the second case, the message is encrypted first. Then the MAC is calculated using the resulting ciphertext and is concatenated to the ciphertext to form the transmitted block. Typically, it is preferable to tie the authentication directly to the plaintext, so the method of Figure 12.4b is used.

Because symmetric encryption will provide authentication and because it is widely used with readily available products, why not simply use this instead of a separate message authentication code? [DAVI89] suggests three situations in which a message authentication code is used.

1. There are a number of applications in which the same message is broadcast to a number of destinations. Examples are notification to users that the network is now unavailable or an alarm signal in a military control center. It is cheaper and more reliable to have only one destination responsible for monitoring authenticity. Thus, the message must be broadcast in plaintext with an associated message authentication code. The responsible system has the secret key and performs authentication. If a violation occurs, the other destination systems are alerted by a general alarm.
2. Another possible scenario is an exchange in which one side has a heavy load and cannot afford the time to decrypt all incoming messages. Authentication is carried out on a selective basis, messages being chosen at random for checking.
3. Authentication of a computer program in plaintext is an attractive service. The computer program can be executed without having to decrypt it every time, which would be wasteful of processor resources. However, if a message authentication code were attached to the program, it could be checked whenever assurance was required of the integrity of the program.

Three other rationales may be added.

4. For some applications, it may not be of concern to keep messages secret, but it is important to authenticate messages. An example is the Simple Network Management Protocol Version 3 (SNMPv3), which separates the functions of confidentiality and authentication. For this application, it is usually important for a managed system to authenticate incoming SNMP messages, particularly if the message contains a command to change parameters at the managed system. On the other hand, it may not be necessary to conceal the SNMP traffic.
5. Separation of authentication and confidentiality functions affords architectural flexibility. For example, it may be desired to perform authentication at the application level but to provide confidentiality at a lower level, such as the transport layer.
6. A user may wish to prolong the period of protection beyond the time of reception and yet allow processing of message contents. With message encryption, the protection is lost when the message is decrypted, so the message is protected against fraudulent modifications only in transit but not within the target system.

Finally, note that the MAC does not provide a digital signature, because both sender and receiver share the same key.

12.3 REQUIREMENTS FOR MESSAGE AUTHENTICATION CODES

A MAC, also known as a cryptographic checksum, is generated by a function MAC of the form

$$T = \text{MAC}(K, M)$$

where M is a variable-length message, K is a secret key shared only by sender and receiver, and $\text{MAC}(K, M)$ is the fixed-length authenticator, sometimes called a **tag**. The tag is appended to the message at the source at a time when the message is assumed or known to be correct. The receiver authenticates that message by recomputing the tag.

When an entire message is encrypted for confidentiality, using either symmetric or asymmetric encryption, the security of the scheme generally depends on the bit length of the key. Barring some weakness in the algorithm, the opponent must resort to a brute-force attack using all possible keys. On average, such an attack will require $2^{(k-1)}$ attempts for a k -bit key. In particular, for a ciphertext-only attack, the opponent, given ciphertext C , performs $P_i = D(K_i, C)$ for all possible key values K_i until a P_i is produced that matches the form of acceptable plaintext.

In the case of a MAC, the considerations are entirely different. In general, the MAC function is a many-to-one function, due to the many-to-one nature of the function. Using brute-force methods, how would an opponent attempt to discover a key? If confidentiality is not employed, the opponent has access to plaintext messages and their associated MACs. Suppose $k > n$; that is, suppose that the key size is greater than the MAC size. Then, given a known M_1 and T_1 , with $T_1 = \text{MAC}(K, M_1)$, the cryptanalyst can perform $T_i = \text{MAC}(K_i, M_1)$ for all possible key values k_i . At least one key is guaranteed to produce a match of $T_i = T_1$. Note that a total of 2^k tags will be produced, but there are only $2^n < 2^k$ different tag values. Thus, a number of keys will produce the correct tag and the opponent has no way of knowing which is the correct key. On average, a total of $2^k/2^n = 2^{(k-n)}$ keys will produce a match. Thus, the opponent must iterate the attack.

■ Round 1

Given: $M_1, T_1 = \text{MAC}(K, M_1)$

Compute $T_i = \text{MAC}(K_i, M_1)$ for all 2^k keys

Number of matches $\approx 2^{(k-n)}$

■ Round 2

Given: $M_2, T_2 = \text{MAC}(K, M_2)$

Compute $T_i = \text{MAC}(K_i, M_2)$ for the $2^{(k-n)}$ keys resulting from Round 1

Number of matches $\approx 2^{(k-2 \times n)}$

And so on. On average, α rounds will be needed $k = \alpha \times n$. For example, if an 80-bit key is used and the tag is 32 bits, then the first round will produce about 2^{48} possible keys. The second round will narrow the possible keys to about 2^{16} possibilities. The third round should produce only a single key, which must be the one used by the sender.

If the key length is less than or equal to the tag length, then it is likely that a first round will produce a single match. It is possible that more than one key will produce such a match, in which case the opponent would need to perform the same test on a new (message, tag) pair.

Thus, a brute-force attempt to discover the authentication key is no less effort and may be more effort than that required to discover a decryption key of the same length. However, other attacks that do not require the discovery of the key are possible.

Consider the following MAC algorithm. Let $M = (X_1 \| X_2 \| \dots \| X_m)$ be a message that is treated as a concatenation of 64-bit blocks X_i . Then define

$$\begin{aligned}\Delta(M) &= X_1 \oplus X_2 \oplus \dots \oplus X_m \\ \text{MAC}(K, M) &= E(K, \Delta(M))\end{aligned}$$

where \oplus is the exclusive-OR (XOR) operation and the encryption algorithm is DES in electronic codebook mode. Thus, the key length is 56 bits, and the tag length is 64 bits. If an opponent observes $\{M \| \text{MAC}(K, M)\}$, a brute-force attempt to determine K will require at least 2^{56} encryptions. But the opponent can attack the system by replacing X_1 through X_{m-1} with any desired values Y_1 through Y_{m-1} and replacing X_m with Y_m , where Y_m is calculated as

$$Y_m = Y_1 \oplus Y_2 \oplus \dots \oplus Y_{m-1} \oplus \Delta(M)$$

The opponent can now concatenate the new message, which consists of Y_1 through Y_m , using the original tag to form a message that will be accepted as authentic by the receiver. With this tactic, any message of length $64 \times (m - 1)$ bits can be fraudulently inserted.

Thus, in assessing the security of a MAC function, we need to consider the types of attacks that may be mounted against it. With that in mind, let us state the requirements for the function. Assume that an opponent knows the MAC function but does not know K . Then the MAC function should satisfy the following requirements.

1. If an opponent observes M and $\text{MAC}(K, M)$, it should be computationally infeasible for the opponent to construct a message M' such that

$$\text{MAC}(K, M') = \text{MAC}(K, M)$$

2. $\text{MAC}(K, M)$ should be uniformly distributed in the sense that for randomly chosen messages, M and M' , the probability that $\text{MAC}(K, M) = \text{MAC}(K, M')$ is 2^{-n} , where n is the number of bits in the tag.
3. Let M' be equal to some known transformation on M . That is, $M' = f(M)$. For example, f may involve inverting one or more specific bits. In that case,

$$\Pr [\text{MAC}(K, M) = \text{MAC}(K, M')] = 2^{-n}$$

The first requirement speaks to the earlier example, in which an opponent is able to construct a new message to match a given tag, even though the opponent does not know and does not learn the key. The second requirement deals with the need to thwart a brute-force attack based on chosen plaintext. That is, if we assume

that the opponent does not know K but does have access to the MAC function and can present messages for MAC generation, then the opponent could try various messages until finding one that matches a given tag. If the MAC function exhibits uniform distribution, then a brute-force method would require, on average, $2^{(n-1)}$ attempts before finding a message that fits a given tag.

The final requirement dictates that the authentication algorithm should not be weaker with respect to certain parts or bits of the message than others. If this were not the case, then an opponent who had M and $\text{MAC}(K, M)$ could attempt variations on M at the known “weak spots” with a likelihood of early success at producing a new message that matched the old tags.

12.4 SECURITY OF MACs

Just as with encryption algorithms and hash functions, we can group attacks on MACs into two categories: brute-force attacks and cryptanalysis.

Brute-Force Attacks

A brute-force attack on a MAC is a more difficult undertaking than a brute-force attack on a hash function because it requires known message-tag pairs. Let us see why this is so. To attack a hash code, we can proceed in the following way. Given a fixed message x with n -bit hash code $h = H(x)$, a brute-force method of finding a collision is to pick a random bit string y and check if $H(y) = H(x)$. The attacker can do this repeatedly off line. Whether an off-line attack can be used on a MAC algorithm depends on the relative size of the key and the tag.

To proceed, we need to state the desired security property of a MAC algorithm, which can be expressed as follows.

- **Computation resistance:** Given one or more text-MAC pairs $[x_i, \text{MAC}(K, x_i)]$, it is computationally infeasible to compute any text-MAC pair $[x, \text{MAC}(K, x)]$ for any new input $x \neq x_i$.

In other words, the attacker would like to come up with the valid MAC code for a given message x . There are two lines of attack possible: attack the key space and attack the MAC value. We examine each of these in turn.

If an attacker can determine the MAC key, then it is possible to generate a valid MAC value for any input x . Suppose the key size is k bits and that the attacker has one known text-tag pair. Then the attacker can compute the n -bit tag on the known text for all possible keys. At least one key is guaranteed to produce the correct tag, namely, the valid key that was initially used to produce the known text-tag pair. This phase of the attack takes a level of effort proportional to 2^k (that is, one operation for each of the 2^k possible key values). However, as was described earlier, because the MAC is a many-to-one mapping, there may be other keys that produce the correct value. Thus, if more than one key is found to produce the correct value, additional text-tag pairs must be tested. It can be shown that the level of effort drops off rapidly with each additional text-MAC pair and that the overall level of effort is roughly 2^k [MENE97].

An attacker can also work on the tag without attempting to recover the key. Here, the objective is to generate a valid tag for a given message or to find a message that matches a given tag. In either case, the level of effort is comparable to that for attacking the one-way or weak collision-resistant property of a hash code, or 2^n . In the case of the MAC, the attack cannot be conducted off line without further input; the attacker will require chosen text-tag pairs or knowledge of the key.

To summarize, the level of effort for brute-force attack on a MAC algorithm can be expressed as $\min(2^k, 2^n)$. The assessment of strength is similar to that for symmetric encryption algorithms. It would appear reasonable to require that the key length and tag length satisfy a relationship such as $\min(k, n) \geq N$, where N is perhaps in the range of 128 bits.

Cryptanalysis

There is much more variety in the structure of MACs than in hash functions, so it is difficult to generalize about the cryptanalysis of MACs. As with encryption algorithms and hash functions, cryptanalytic attacks on MAC algorithms seek to exploit some property of the algorithm to perform some attack other than an exhaustive search. The way to measure the resistance of a MAC algorithm to cryptanalysis is to compare its strength to the effort required for a brute-force attack. That is, an ideal MAC algorithm will require a cryptanalytic effort greater than or equal to the brute-force effort.

12.5 MACs BASED ON HASH FUNCTIONS: HMAC

Later in this chapter, we look at examples of a MAC based on the use of a symmetric block cipher. This has traditionally been the most common approach to constructing a MAC. In recent years, there has been increased interest in developing a MAC derived from a **cryptographic hash function**. The motivations for this interest are

1. Cryptographic hash functions such as MD5 and SHA generally execute faster in software than symmetric block ciphers such as DES.
2. Library code for cryptographic hash functions is widely available.

With the development of AES and the more widespread availability of code for encryption algorithms, these considerations are less significant, but hash-based MACs continue to be widely used.

A hash function such as SHA was not designed for use as a MAC and cannot be used directly for that purpose, because it does not rely on a secret key. There have been a number of proposals for the incorporation of a secret key into an existing hash algorithm. The approach that has received the most support is HMAC [BELL96a, BELL96b]. HMAC has been issued as RFC 2104, has been chosen as the mandatory-to-implement MAC for IP security, and is used in other Internet protocols, such as SSL. HMAC has also been issued as a NIST standard (FIPS 198).

HMAC Design Objectives

RFC 2104 lists the following design objectives for HMAC.

- To use, without modifications, available hash functions. In particular, to use hash functions that perform well in software and for which code is freely and widely available.
- To allow for easy replaceability of the embedded hash function in case faster or more secure hash functions are found or required.
- To preserve the original performance of the hash function without incurring a significant degradation.
- To use and handle keys in a simple way.
- To have a well understood cryptographic analysis of the strength of the authentication mechanism based on reasonable assumptions about the embedded hash function.

The first two objectives are important to the acceptability of HMAC. HMAC treats the hash function as a “black box.” This has two benefits. First, an existing implementation of a hash function can be used as a module in implementing HMAC. In this way, the bulk of the HMAC code is prepackaged and ready to use without modification. Second, if it is ever desired to replace a given hash function in an HMAC implementation, all that is required is to remove the existing hash function module and drop in the new module. This could be done if a faster hash function were desired. More important, if the security of the embedded hash function were compromised, the security of HMAC could be retained simply by replacing the embedded hash function with a more secure one (e.g., replacing SHA-2 with SHA-3).

The last design objective in the preceding list is, in fact, the main advantage of HMAC over other proposed hash-based schemes. HMAC can be proven secure provided that the embedded hash function has some reasonable cryptographic strengths. We return to this point later in this section, but first we examine the structure of HMAC.

HMAC Algorithm

Figure 12.5 illustrates the overall operation of HMAC. Define the following terms.

H = embedded hash function (e.g., MD5, SHA-1, RIPEMD-160)

IV = initial value input to hash function

M = message input to HMAC (including the padding specified in the embedded hash function)

Y_i = i th block of M , $0 \leq i \leq (L - 1)$

L = number of blocks in M

b = number of bits in a block

n = length of hash code produced by embedded hash function

K = secret key; recommended length is $\geq n$; if key length is greater than b , the key is input to the hash function to produce an n -bit key

K^+ = K padded with zeros on the right so that the result is b bits in length

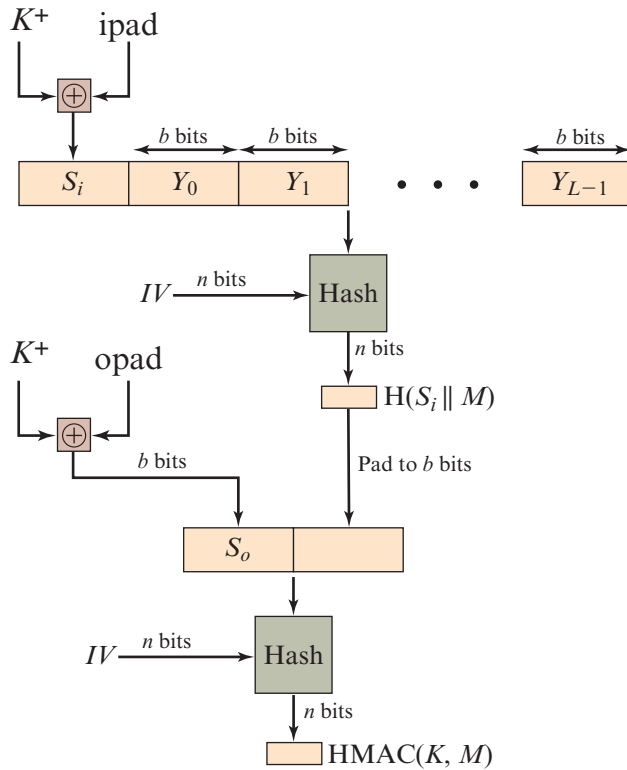

Figure 12.5 HMAC Structure

$ipad = 00110110$ (36 in hexadecimal) repeated $b/8$ times
 $opad = 01011100$ (5C in hexadecimal) repeated $b/8$ times

Then HMAC can be expressed as

$$HMAC(K, M) = H[(K^+ \oplus opad) || H[(K^+ \oplus ipad) || M]]$$

We can describe the algorithm as follows.

1. Append zeros to the left end of K to create a b -bit string K^+ (e.g., if K is of length 160 bits and $b = 512$, then K will be appended with 44 zeroes).
2. XOR (bitwise exclusive-OR) K^+ with $ipad$ to produce the b -bit block S_i .
3. Append M to S_i .
4. Apply H to the stream generated in step 3.
5. XOR K^+ with $opad$ to produce the b -bit block S_o .
6. Append the hash result from step 4 to S_o .
7. Apply H to the stream generated in step 6 and output the result.

Note that the XOR with $ipad$ results in flipping one-half of the bits of K . Similarly, the XOR with $opad$ results in flipping one-half of the bits of K , using a

different set of bits. In effect, by passing S_i and S_o through the compression function of the hash algorithm, we have pseudorandomly generated two keys from K .

HMAC should execute in approximately the same time as the embedded hash function for long messages. HMAC adds three executions of the hash compression function (for S_i , S_o , and the block produced from the inner hash).

A more efficient implementation is possible, as shown in Figure 12.6. Two quantities are precomputed:

$$f(IV, (K^+ \oplus \text{ipad}))$$

$$f(IV, (K^+ \oplus \text{opad}))$$

where $f(\text{cv}, \text{block})$ is the compression function for the hash function, which takes as arguments a chaining variable of n bits and a block of b bits and produces a chaining variable of n bits. These quantities only need to be computed initially and every time the key changes. In effect, the precomputed quantities substitute for the initial value (IV) in the hash function. With this implementation, only one additional instance of the compression function is added to the processing normally produced by the hash

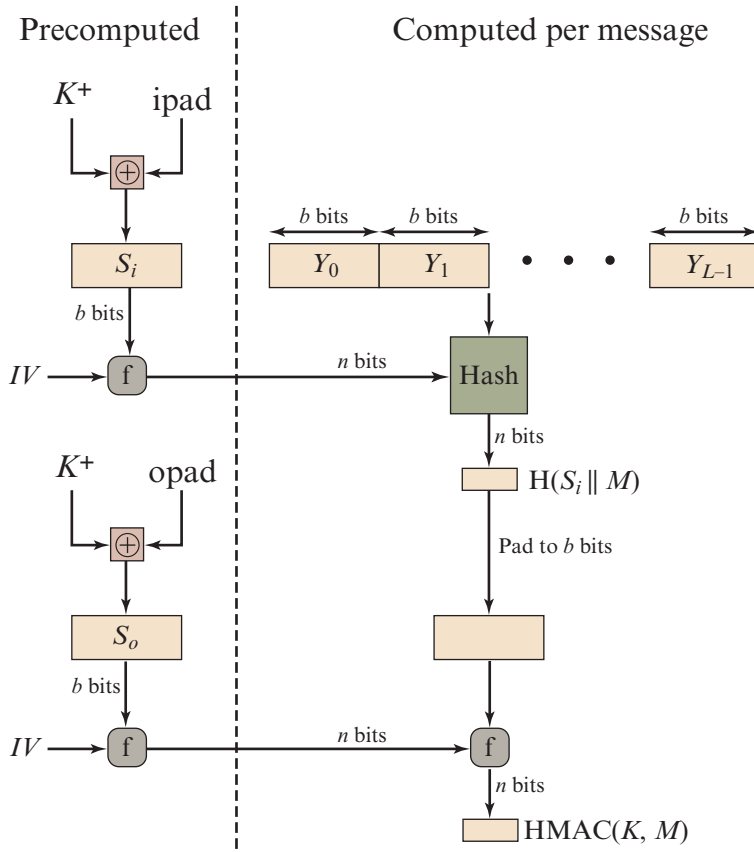

Figure 12.6 Efficient Implementation of HMAC

function. This more efficient implementation is especially worthwhile if most of the messages for which a MAC is computed are short.

Security of HMAC

The security of any MAC function based on an embedded hash function depends in some way on the cryptographic strength of the underlying hash function. The appeal of HMAC is that its designers have been able to prove an exact relationship between the strength of the embedded hash function and the strength of HMAC.

The security of a MAC function is generally expressed in terms of the probability of successful forgery with a given amount of time spent by the forger and a given number of message-tag pairs created with the same key. In essence, it is proved in [BELL96a] that for a given level of effort (time, message-tag pairs) on messages generated by a legitimate user and seen by the attacker, the probability of successful attack on HMAC is equivalent to one of the following attacks on the embedded hash function.

1. The attacker is able to compute an output of the compression function even with an IV that is random, secret, and unknown to the attacker.
2. The attacker finds collisions in the hash function even when the IV is random and secret.

In the first attack, we can view the compression function as equivalent to the hash function applied to a message consisting of a single b -bit block. For this attack, the IV of the hash function is replaced by a secret, random value of n bits. An attack on this hash function requires either a brute-force attack on the key, which is a level of effort on the order of 2^n , or a birthday attack, which is a special case of the second attack, discussed next.

In the second attack, the attacker is looking for two messages M and M' that produce the same hash: $H(M) = H(M')$. This is the birthday attack discussed in Chapter 11. We have shown that this requires a level of effort of $2^{n/2}$ for a hash length of n . On this basis, the security of MD5 is called into question, because a level of effort of 2^{64} looks feasible with today's technology. Does this mean that a 128-bit hash function such as MD5 is unsuitable for HMAC? The answer is no, because of the following argument. To attack MD5, the attacker can choose any set of messages and work on these off line on a dedicated computing facility to find a collision. Because the attacker knows the hash algorithm and the default IV , the attacker can generate the hash code for each of the messages that the attacker generates. However, when attacking HMAC, the attacker cannot generate message/code pairs off line because the attacker does not know K . Therefore, the attacker must observe a sequence of messages generated by HMAC under the same key and perform the attack on these known messages. For a hash code length of 128 bits, this requires 2^{64} observed blocks (2^{72} bits) generated using the same key. On a 1-Gbps link, one would need to observe a continuous stream of messages with no change in key for about 250,000 years in order to succeed. Thus, if speed is a concern, it is fully acceptable to use MD5 rather than SHA-1 as the embedded hash function for HMAC.

12.6 MACs BASED ON BLOCK CIPHERS: DAA AND CMAC

In this section, we look at two MACs that are based on the use of a block cipher mode of operation. We begin with an older algorithm, the Data Authentication Algorithm (DAA), which is now obsolete. Then we examine CMAC, which is designed to overcome the deficiencies of DAA.

Data Authentication Algorithm

The Data Authentication Algorithm (DAA), based on DES, has been one of the most widely used MACs for a number of years. The algorithm is both a FIPS publication (FIPS PUB 113) and an ANSI standard (X9.17). However, as we discuss subsequently, security weaknesses in this algorithm have been discovered, and it is being replaced by newer and stronger algorithms.

The algorithm can be defined as using the cipher block chaining (CBC) mode of operation of DES (Figure 6.4) with an initialization vector of zero. The data (e.g., message, record, file, or program) to be authenticated are grouped into contiguous 64-bit blocks: D_1, D_2, \dots, D_N . If necessary, the final block is padded on the right with zeroes to form a full 64-bit block. Using the DES encryption algorithm E and a secret key K , a data authentication code (DAC) is calculated as follows (Figure 12.7).

$$\begin{aligned} O_1 &= E(K, D) \\ O_2 &= E(K, [D_2 \oplus O_1]) \\ O_3 &= E(K, [D_3 \oplus O_2]) \\ &\vdots \\ &\vdots \\ &\vdots \\ O_N &= E(K, [D_N \oplus O_{N-1}]) \end{aligned}$$

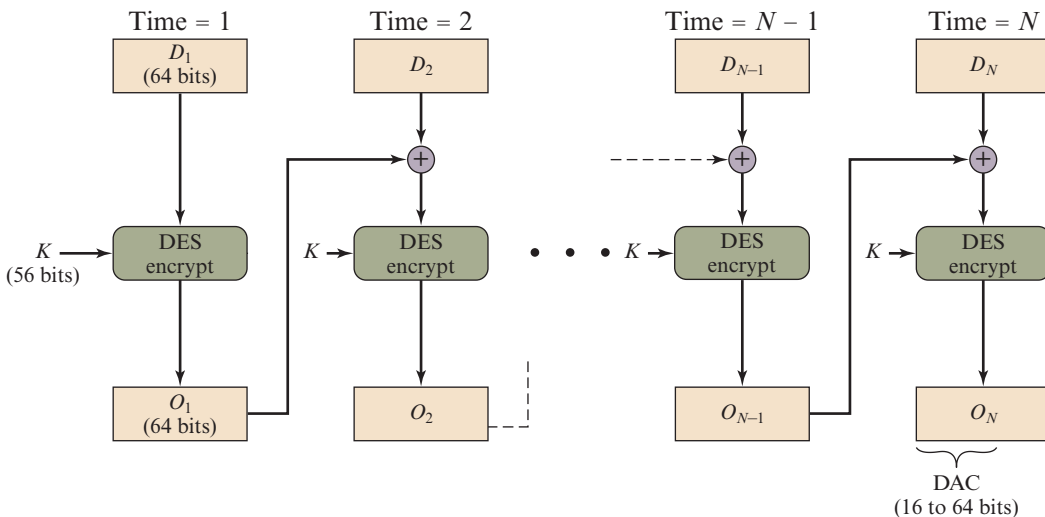

Figure 12.7 Data Authentication Algorithm (FIPS PUB 113)

The DAC consists of either the entire block O_N or the leftmost M bits of the block, with $16 \leq M \leq 64$.

Cipher-Based Message Authentication Code (CMAC)

As was mentioned, DAA has been widely adopted in government and industry. [BELL00] demonstrated that this MAC is secure under a reasonable set of security criteria, with the following restriction. Only messages of one fixed length of mn bits are processed, where n is the cipher block size and m is a fixed positive integer. As a simple example, notice that given the CBC MAC of a one-block message X , say $T = \text{MAC}(K, X)$, the adversary immediately knows the CBC MAC for the two-block message $X || (X \oplus T)$ since this is once again T .

Black and Rogaway [BLAC00] demonstrated that this limitation could be overcome using three keys: one key K of length k to be used at each step of the cipher block chaining and two keys of length b , where b is the cipher block length. This proposed construction was refined by Iwata and Kurosawa so that the two n -bit keys could be derived from the encryption key, rather than being provided separately [IWAT03]. This refinement, adopted by NIST, is the Cipher-based Message Authentication Code (**CMAC**) mode of operation for use with AES and triple DES. It is specified in NIST Special Publication 800-38B.

First, let us define the operation of CMAC when the message is an integer multiple n of the cipher block length b . For AES, $b = 128$, and for triple DES, $b = 64$. The message is divided into n blocks (M_1, M_2, \dots, M_n) . The algorithm makes use of a k -bit encryption key K and a b -bit constant, K_1 . For AES, the key size k is 128, 192, or 256 bits; for triple DES, the key size is 112 or 168 bits. CMAC is calculated as follows (Figure 12.8).

$$\begin{aligned} C_1 &= E(K, M_1) \\ C_2 &= E(K, [M_2 \oplus C_1]) \\ C_3 &= E(K, [M_3 \oplus C_2]) \\ &\cdot \\ &\cdot \\ &\cdot \\ C_n &= E(K, [M_n \oplus C_{n-1} \oplus K_1]) \\ T &= \text{MSB}_{Tlen}(C_n) \end{aligned}$$

where

$$\begin{aligned} T &= \text{message authentication code, also referred to as the tag} \\ Tlen &= \text{bit length of } T \\ \text{MSB}_s(X) &= \text{the } s \text{ leftmost bits of the bit string } X \end{aligned}$$

If the message is not an integer multiple of the cipher block length, then the final block is padded to the right (least significant bits) with a 1 and as many 0s as necessary so that the final block is also of length b . The CMAC operation then proceeds as before, except that a different b -bit key K_2 is used instead of K_1 .

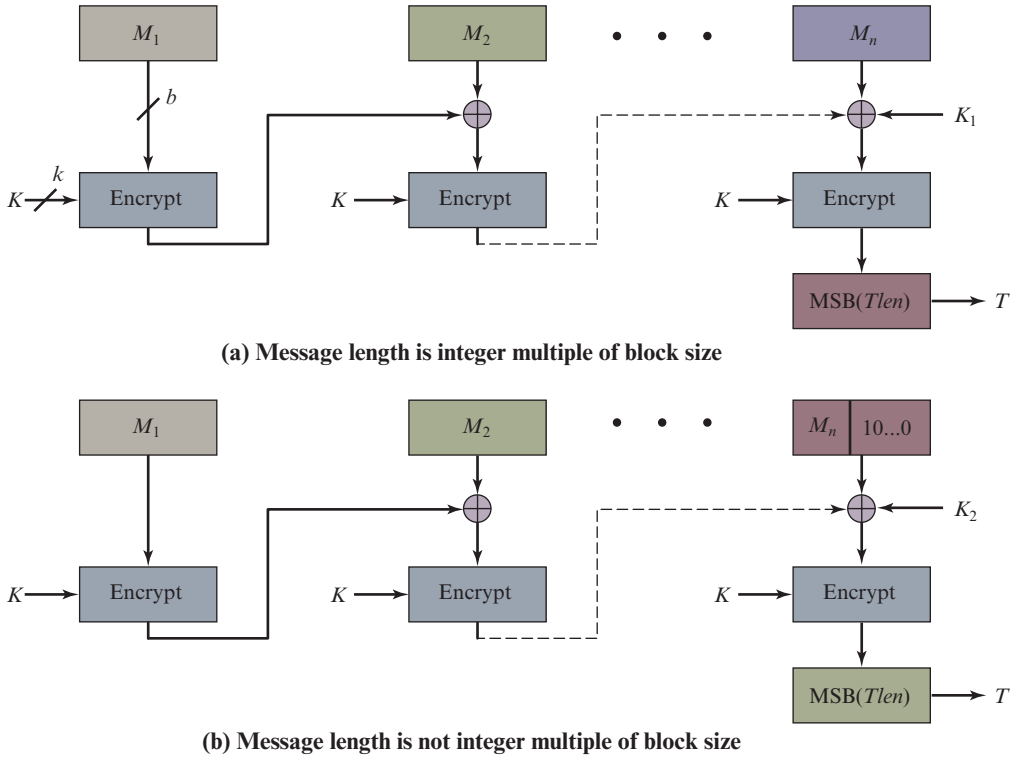

Figure 12.8 Cipher-based Message Authentication Code (CMAC)

The two b -bit keys are derived from the k -bit encryption key as follows.

$$\begin{aligned}
 L &= E(K, 0^b) \\
 K_1 &= L \cdot x \\
 K_2 &= L \cdot x^2 = (L \cdot x) \cdot x
 \end{aligned}$$

where multiplication (\cdot) is done in the finite field $GF(2^b)$ and x and x^2 are first- and second-order polynomials that are elements of $GF(2^b)$. Thus, the binary representation of x consists of $b - 2$ zeros followed by 10; the binary representation of x^2 consists of $b - 3$ zeros followed by 100. The finite field is defined with respect to an irreducible polynomial that is lexicographically first among all such polynomials with the minimum possible number of nonzero terms. For the two approved block sizes, the polynomials are $x^{64} + x^4 + x^3 + x + 1$ and $x^{128} + x^7 + x^2 + x + 1$.

To generate K_1 and K_2 , the block cipher is applied to the block that consists entirely of 0 bits. The first subkey is derived from the resulting ciphertext by a left shift of one bit and, conditionally, by XORing a constant that depends on the block size. The second subkey is derived in the same manner from the first subkey. This property of finite fields of the form $GF(2^b)$ was explained in the discussion of MixColumns in Chapter 6.

12.7 AUTHENTICATED ENCRYPTION: CCM AND GCM

Authenticated encryption (AE) is a term used to describe encryption systems that simultaneously protect confidentiality and authenticity (integrity) of communications. Many applications and protocols require both forms of security, but until recently the two services have been designed separately.

There are four common approaches to providing both confidentiality and encryption for a message M .

- **Hashing followed by encryption ($H \rightarrow E$):** First compute the cryptographic hash function over M as $h = H(M)$. Then encrypt the message plus hash function: $E(K, (M \| h))$.
- **Authentication followed by encryption ($A \rightarrow E$):** Use two keys. First authenticate the plaintext by computing the MAC value as $T = \text{MAC}(K_1, M)$. Then encrypt the message plus tag: $E(K_2, [M \| T])$. This approach is taken by the SSL/TLS protocols (Chapter 19).
- **Encryption followed by authentication ($E \rightarrow A$):** Use two keys. First encrypt the message to yield the ciphertext $C = E(K_2, M)$. Then authenticate the ciphertext with $T = \text{MAC}(K_1, C)$ to yield the pair (C, T) . This approach is used in the IPsec protocol (Chapter 22).
- **Independently encrypt and authenticate ($E + A$):** Use two keys. Encrypt the message to yield the ciphertext $C = E(K_2, M)$. Authenticate the plaintext with $T = \text{MAC}(K_1, M)$ to yield the pair (C, T) . These operations can be performed in either order. This approach is used by the SSH protocol (Chapter 19).

Both decryption and verification are straightforward for each approach. For $H \rightarrow E$, $A \rightarrow E$, and $E + A$, decrypt first, then verify. For $E \rightarrow A$, verify first, then decrypt. There are security vulnerabilities with all of these approaches. The $H \rightarrow E$ approach is used in the Wired Equivalent Privacy (WEP) protocol to protect WiFi networks. This approach had fundamental weaknesses and led to the replacement of the WEP protocol. [BLAC05] and [BELL00] point out that there are security concerns in each of the three encryption/MAC approaches listed above. Nevertheless, with proper design, any of these approaches can provide a high level of security. This is the goal of the two approaches discussed in this section, both of which have been standardized by NIST.

Counter with Cipher Block Chaining–Message Authentication Code

The **CCM** mode of operation was standardized by NIST specifically to support the security requirements of IEEE 802.11 WiFi wireless local area networks (Chapter 20), but can be used in any networking application requiring authenticated encryption. CCM is a variation of the encrypt-and-MAC approach to authenticated encryption. It is defined in NIST SP 800-38C.

The key algorithmic ingredients of CCM are the AES encryption algorithm (Chapter 6), the CTR mode of operation (Chapter 7), and the CMAC authentication

algorithm (Section 12.6). A single key K is used for both encryption and MAC algorithms. The input to the CCM encryption process consists of three elements.

1. Data that will be both authenticated and encrypted. This is the plaintext message P of data block.
2. Associated data A that will be authenticated but not encrypted. An example is a protocol header that must be transmitted in the clear for proper protocol operation but which needs to be authenticated.
3. A nonce N that is assigned to the payload and the associated data. This is a unique value that is different for every instance during the lifetime of a protocol association and is intended to prevent replay attacks and certain other types of attacks.

Figure 12.9 illustrates the operation of CCM. For authentication, the input includes the nonce, the associated data, and the plaintext. This input is formatted as a sequence of blocks B_0 through B_r . The first block contains the nonce plus some formatting bits that indicate the lengths of the N , A , and P elements. This is followed by zero or more blocks that contain A , followed by zero or more blocks that contain P . The resulting sequence of blocks serves as input to the CMAC algorithm, which produces a MAC value with length $Tlen$, which is less than or equal to the block length (Figure 12.9a).

For encryption, a sequence of counters is generated that must be independent of the nonce. The authentication tag is encrypted in CTR mode using the single counter Ctr_0 . The $Tlen$ most significant bits of the output are XORed with the tag to produce an encrypted tag. The remaining counters are used for the CTR mode encryption of the plaintext (Figure 7.7). The encrypted plaintext is concatenated with the encrypted tag to form the ciphertext output (Figure 12.9b).

SP 800-38C defines the authentication/encryption process as follows.

1. Apply the formatting function to (N, A, P) to produce the blocks B_0, B_1, \dots, B_r .
2. Set $Y_0 = E(K, B_0)$.
3. For $i = 1$ to r , do $Y_i = E(K, (B_i \oplus Y_{i-1}))$.
4. Set $T = MSB_{Tlen}(Y_r)$.
5. Apply the counter generation function to generate the counter blocks $Ctr_0, Ctr_1, \dots, Ctr_m$, where $m = \lceil Plen/128 \rceil$.
6. For $j = 0$ to m , do $S_j = E(K, Ctr_j)$.
7. Set $S = S_1 \| S_2 \| \dots \| S_m$.
8. Return $C = (P \oplus MSB_{Plen}(S)) \| (T \oplus MSB_{Tlen}(S_0))$.

For decryption and verification, the recipient requires the following input: the ciphertext C , the nonce N , the associated data A , the key K , and the initial counter Ctr_0 . The steps are as follows.

1. If $Clen \leq Tlen$, then return INVALID.
2. Apply the counter generation function to generate the counter blocks $Ctr_0, Ctr_1, \dots, Ctr_m$, where $m = \lceil Clen/128 \rceil$.
3. For $j = 0$ to m , do $S_j = E(K, Ctr_j)$.

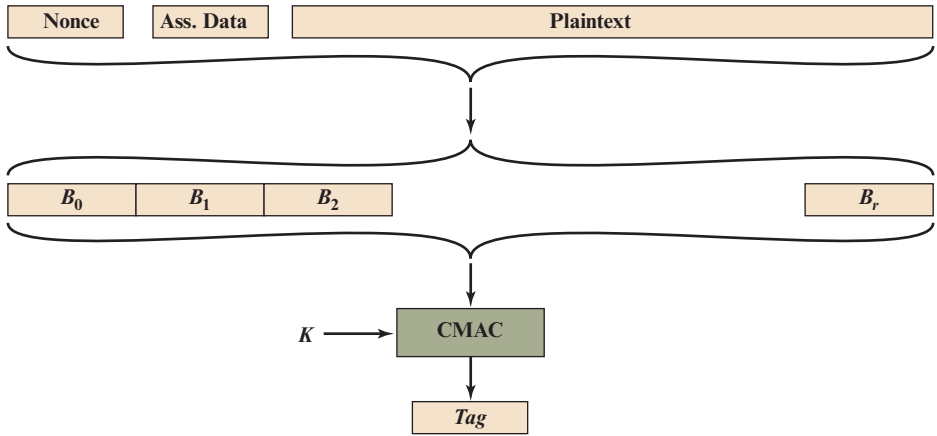

(a) Authentication

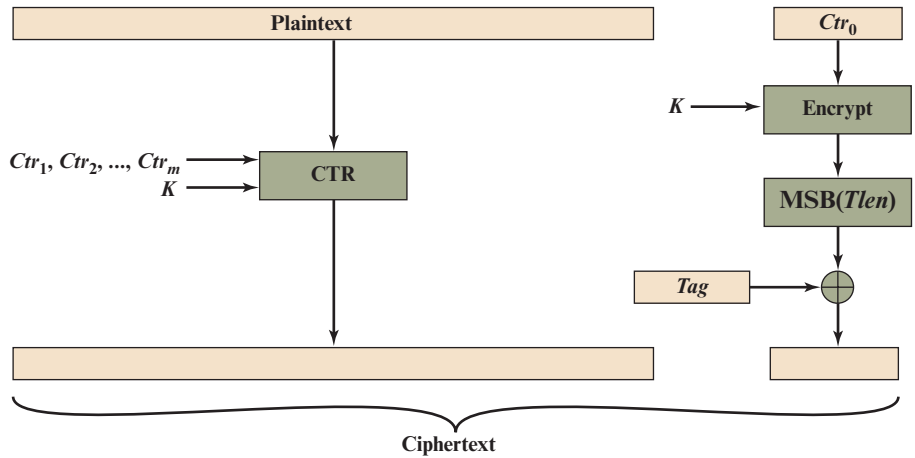

(b) Encryption

Figure 12.9 Counter with Cipher Block Chaining-Message Authentication Code (CCM)

4. Set $S = S_1 \| S_2 \| \dots \| S_m$.
5. Set $P = MSB_{Clen-Tlen}(C) \oplus MSB_{Clen-Tlen}(S)$.
6. Set $T = LSB_{Tlen}(C) \oplus MSB_{Tlen}(S_0)$.
7. Apply the formatting function to (N, A, P) to produce the blocks B_0, B_1, \dots, B_r .
8. Set $Y_0 = E(K, B_0)$.
9. For $i = 1$ to r do $Y_i = E(K, (B_i \oplus Y_{i-1}))$.
10. If $T \neq MSB_{Tlen}(Y_r)$, then return INVALID, else return P .

CCM is a relatively complex algorithm. Note that it requires two complete passes through the plaintext, once to generate the MAC value, and once for encryption. Further, the details of the specification require a tradeoff between the length of the nonce and the length of the tag, which is an unnecessary restriction. Also note that the encryption key is used twice with the CTR encryption mode: once to generate the tag and once to encrypt the plaintext plus tag. Whether these complexities add to the security of the algorithm is not clear. In any case, two analyses of the algorithm ([JONS02] and [ROGA03]) conclude that CCM provides a high level of security.

Galois/Counter Mode

The GCM mode of operation, standardized by NIST in NIST SP 800-38D, is designed to be parallelizable so that it can provide high throughput with low cost and low latency. In essence, the message is encrypted in variant of CTR mode. The resulting ciphertext is multiplied with key material and message length information over $\text{GF}(2^{128})$ to generate the authenticator tag. The standard also specifies a mode of operation that supplies the MAC only, known as GMAC.

The GCM mode makes use of two functions: GHASH, which is a keyed hash function, and GCTR, which is essentially the CTR mode with the counters determined by a simple increment by one operation.

GHASH_H(X) takes a input the hash key H and a bit string X such that $\text{len}(X) = 128m$ bits for some positive integer m and produces a 128-bit MAC value. The function may be specified as follows (Figure 12.10a).

1. Let $X_1, X_2, \dots, X_{m-1}, X_m$ denote the unique sequence of blocks such that $X = X_1 \parallel X_2 \parallel \dots \parallel X_{m-1} \parallel X_m$.
2. Let Y_0 be a block of 128 zeros, designated as 0^{128} .
3. For $i = 1, \dots, m$, let $Y_i = (Y_{i-1} \oplus X_i) \cdot H$, where \cdot designates multiplication in $\text{GF}(2^{128})$.
4. Return Y_m .

The GHASH_H(X) function can be expressed as

$$(X_1 \cdot H^m) \oplus (X_2 \cdot H^{m-1}) \oplus \dots \oplus (X_{m-1} \cdot H^2) \oplus (X_m \cdot H)$$

This formulation has desirable performance implications. If the same hash key is to be used to authenticate multiple messages, then the values H^2, H^3, \dots can be precalculated one time for use with each message to be authenticated. Then, the blocks of the data to be authenticated (X_1, X_2, \dots, X_m) can be processed in parallel, because the computations are independent of one another.

GCTR_K(ICB, X) takes a input a secret key K and a bit string X arbitrary length and returns a ciphertext Y of bit length (X) . The function may be specified as follows (Figure 12.10b).

1. If X is the empty string, then return the empty string as Y .
2. Let $n = \lceil (\text{len}(X)/128) \rceil$. That is, n is the smallest integer greater than or equal to $(X)/128$.

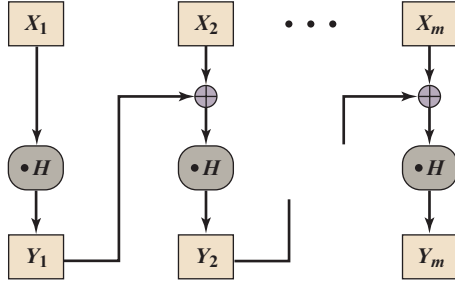

(a) $\text{GHASH}_H(X_1 \parallel X_2 \parallel \dots \parallel X_m) = Y_m$

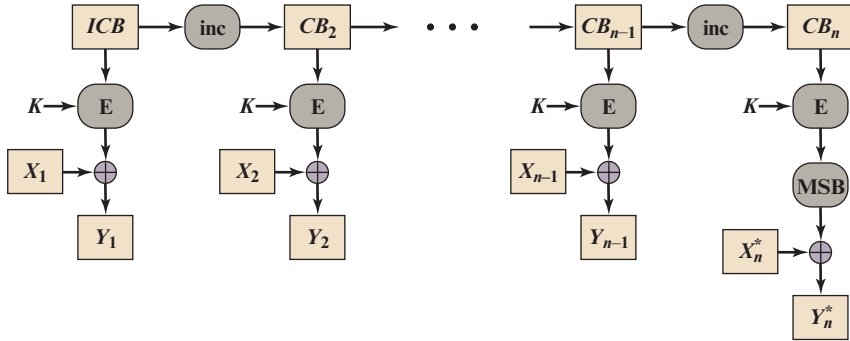

(b) $\text{GCTR}_K(\text{ICB}, X_1 \parallel X_2 \parallel \dots \parallel X_n^*) = Y_1 \parallel Y_2 \parallel \dots \parallel Y_n^*$

Figure 12.10 GCM Authentication and Encryption Functions

3. Let $X_1, X_2, \dots, X_{n-1}, X_n^*$ denote the unique sequence of bit strings such that

$$X = X_1 \parallel X_2 \parallel \dots \parallel X_{n-1} \parallel X_n^*;$$

X_1, X_2, \dots, X_{n-1} are complete 128-bit blocks.

4. Let $CB_1 = \text{ICB}$.
5. For, $i = 2$ to n let $CB_i = \text{inc}_{32}(CB_{i-1})$, where the $\text{inc}_{32}(S)$ function increments the rightmost 32 bits of S by $1 \bmod 2^{32}$, and the remaining bits are unchanged.
6. For $i = 1$ to $n - 1$, do $Y_i = X_i \oplus \text{E}(K, CB_i)$.
7. Let $Y_n^* = X_n^* \oplus \text{MSB}_{\text{len}(X_n^*)}(\text{E}(K, CB_n))$.
8. Let $Y = Y_1 \parallel Y_2 \parallel \dots \parallel Y_{n-1} \parallel Y_n^*$
9. Return Y .

Note that the counter values can be quickly generated and that the encryption operations can be performed in parallel.

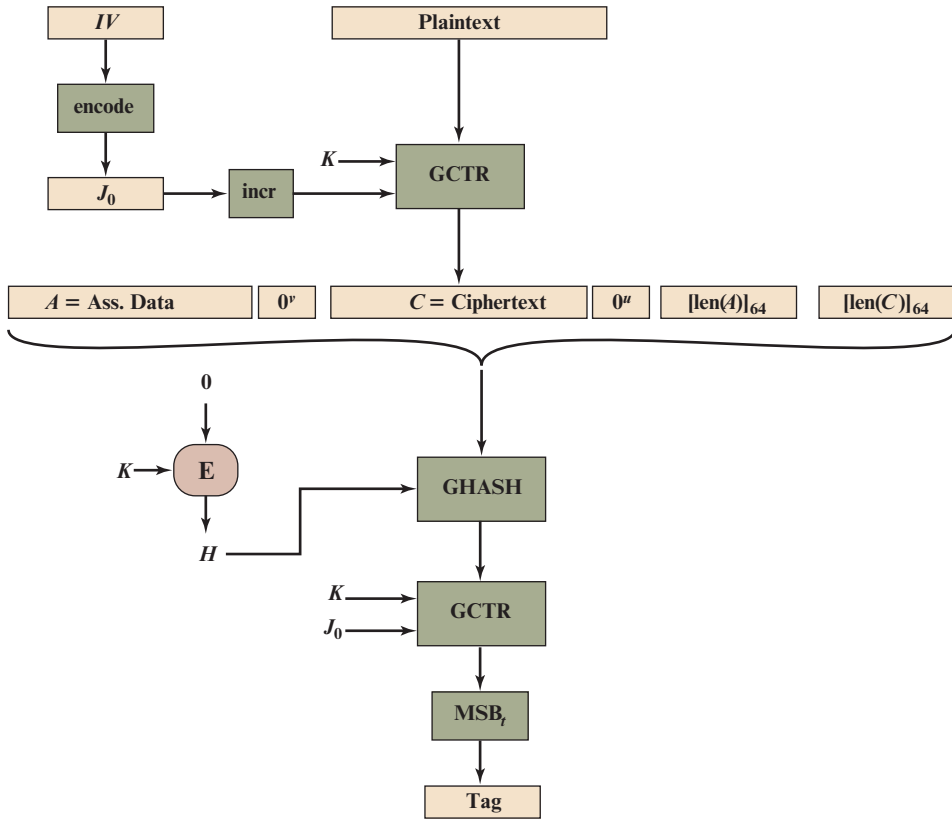

Figure 12.11 Galois Counter—Message Authentication Code (GCM)

We can now define the overall authenticated encryption function (Figure 12.11). The input consists of a secret key K , an initialization vector IV , a plaintext P , and additional authenticated data A . The notation $[x]_s$ means the s -bit binary representation of the nonnegative integer x . The steps are as follows.

1. Let $H = E(K, 0^{128})$.
2. Define a block, J_0 , as
 If $\text{len}(IV) = 96$, then let $J_0 = IV \parallel 0^{31} \parallel 1$.
 If $\text{len}(IV) \neq 96$, then let $s = 128 \lceil \text{len}(IV)/128 \rceil - \text{len}(IV)$, and let
 $J_0 = \text{GHASH}_H(IV \parallel 0^{s+64} \parallel [\text{len}(IV)]_{64})$.
3. Let $C = \text{GCTR}_K(\text{inc}_{32}(J_0), P)$.
4. Let $u = 128 \lceil \text{len}(C)/128 \rceil - \text{len}(C)$ and let $v = 128 \lceil \text{len}(A)/128 \rceil - \text{len}(A)$.
5. Define a block, S , as

$$S = \text{GHASH}_H(A \parallel 0^v \parallel C \parallel 0^u \parallel [\text{len}(A)]_{64} \parallel [\text{len}(C)]_{64})$$

6. Let $T = \text{MSB}_t(\text{GCTR}_K(J_0, S))$, where t is the supported tag length.
7. Return (C, T) .

In step 1, the hash key is generated by encrypting a block of all zeros with the secret key K . In step 2, the pre-counter block (J_0) is generated from the IV . In particular, when the length of the IV is 96 bits, then the padding string $0^{31} \parallel 1$ is appended to the IV to form the pre-counter block. Otherwise, the IV is padded with the minimum number of 0 bits, possibly none, so that the length of the resulting string is a multiple of 128 bits (the block size); this string in turn is appended with 64 additional 0 bits, followed by the 64-bit representation of the length of the IV , and the GHASH function is applied to the resulting string to form the pre-counter block.

Thus, GCM is based on the CTR mode of operation and adds a MAC that authenticates both the message and additional data that requires only authentication. The function that computes the hash uses only multiplication in a Galois field. This choice was made because the operation of multiplication is easy to perform within a Galois field and is easily implemented in hardware [MCGR03].

[MCGR04] examines the available block cipher modes of operation and shows that a CTR-based authenticated encryption approach is the most efficient mode of operation for high-speed packet networks. The paper further demonstrates that GCM meets a high level of security requirements.

12.8 KEY WRAPPING

Background

The most recent block cipher mode of operation defined by NIST is the **Key Wrap (KW) mode** of operation (SP 800-38F), which uses AES or triple DEA as the underlying encryption algorithm. The AES version is also documented in RFC 3394.

The purpose of **key wrapping** is to securely exchange a symmetric key to be shared by two parties, using a symmetric key already shared by those parties. The latter key is called a **key encryption key (KEK)**.

Two questions need to be addressed at this point. First, why do we need to use a symmetric key already known to two parties to encrypt a new symmetric key? Such a requirement is found in a number of protocols described in this book, such as the key management portion of IEEE 802.11 and IPsec. This question is explored in Chapter 14.

The second question is, why do we need a new mode? The intent of the new mode is to operate on keys whose length is greater than the block size of the encryption algorithm. For example, AES uses a block size of 128 bits but can use a key size of 128, 192, or 256 bits. In the latter two cases, encryption of the key involves multiple blocks. We consider the value of key data to be greater than the value of other data, because the key will be used multiple times, and compromise of the key compromises all of the data encrypted with the key. Therefore, NIST desired a robust encryption mode. KW is robust in the sense that each bit of output can be expected

to depend in a nontrivial fashion on each bit of input. This is not the case for any of the other modes of operation that we have described. For example, in all of the modes so far described, the last block of plaintext only influences the last block of ciphertext. Similarly, the first block of ciphertext is derived only from the first block of plaintext.

To achieve this robust operation, KW achieves a considerably lower throughput than the other modes, but the tradeoff may be appropriate for some key management applications. Also, KW is only used for small amounts of plaintext compared to, say, the encryption of a message or a file.

The Key Wrapping Algorithm

The key wrapping algorithm operates on blocks of 64 bits. The input to the algorithm consists of a 64-bit constant, discussed subsequently, and a plaintext key that is divided into blocks of 64 bits. We use the following notation:

$MSB_{64}(W)$	most significant 64 bits of W
$LSB_{64}(W)$	least significant 64 bits of W
W	temporary value; output of encryption function
\oplus	bitwise exclusive-OR
\parallel	concatenation
K	key encryption key
n	number of 64-bit key data blocks
s	number of stages in the wrapping process; $s = 6n$
P_i	i th plaintext key data block; $1 \leq i \leq n$
C_i	i th ciphertext data block; $0 \leq i \leq n$
$A(t)$	64-bit integrity check register after encryption stage t ; $1 \leq t \leq s$
$A(0)$	initial integrity check value (ICV); in hexadecimal: A6A6A6A6A6A6A6A6
$R(t, i)$	64-bit register i after encryption stage t ; $1 \leq t \leq s$; $1 \leq i \leq n$

We now describe the key wrapping algorithm:

Inputs: Plaintext, n 64-bit values (P_1, P_2, \dots, P_n)

Key encryption key, K

Outputs: Ciphertext, $(n + 1)$ 64-bit values (C_0, C_1, \dots, C_n)

1. Initialize variables.

$A(0) = A6A6A6A6A6A6A6A6$

for $i = 1$ **to** n

$R(0, i) = P_i$

2. Calculate intermediate values.

```

for  $t = 1$  to  $s$ 
 $W = E(K, [A(t-1) \parallel R(t-1, 1)])$ 
 $A(t) = t \oplus \text{MSB}_{64}(W)$ 
 $R(t, n) = \text{LSB}_{64}(W)$ 
for  $i = 1$  to  $n-1$ 
 $R(t, i) = R(t-1, i+1)$ 

```

3. Output results.

```

 $C_0 = A(s)$ 
for  $i = 1$  to  $n$ 
 $C_i = R(s, i)$ 

```

Note that the ciphertext is one block longer than the plaintext key, to accommodate the ICV. Upon unwrapping (decryption), both the 64-bit ICV and the plaintext key are recovered. If the recovered ICV differs from the input value of hexadecimal A6A6A6A6A6A6A6A6, then an error or alteration has been detected and the plaintext key is rejected. Thus, the key wrap algorithm provides not only confidentiality but also data integrity.

Figure 12.12 illustrated the key wrapping algorithm for encrypting a 256-bit key. Each box represents one encryption stage (one value of t). Note that the A output is fed as input to the next stage ($t + 1$), whereas the R output skips forward n stages ($t + n$), which in this example is $n = 4$. This arrangement further increases the avalanche effect and the mixing of bits. To achieve this skipping of stages, a sliding buffer is used, so that the R output from stage t is shifted in the buffer one position for each stage, until it becomes the input for stage $t + n$. This might be clearer if we expand the inner **for** loop for a 256-bit key ($n = 4$). Then the assignments are as follows:

$$\begin{aligned}
 R(t, 1) &= R(t - 1, 2) \\
 R(t, 2) &= R(t - 1, 3) \\
 R(t, 3) &= R(t - 1, 4)
 \end{aligned}$$

For example, consider that at stage 5, the R output has a value of $R(5, 4) = x$. At stage 6, we execute $R(6, 3) = R(5, 4) = x$. At stage 7, we execute $R(7, 2) = R(6, 3) = x$. At stage 8, we execute $R(8, 1) = R(7, 2) = x$. So, at stage 9, the input value of $R(t - 1, 1)$ is $R(8, 1) = x$.

Figure 12.13 depicts the operation of stage t for a 256-bit key. The dashed feedback lines indicate the assignment of new values to the stage variables.

Key Unwrapping

The key unwrapping algorithm can be defined as follows:

Inputs: Ciphertext, $(n + 1)$ 64-bit values (C_0, C_1, \dots, C_n)
 Key encryption key, K

Outputs: Plaintext, n 64-bit values (P_1, P_2, \dots, P_n), ICV

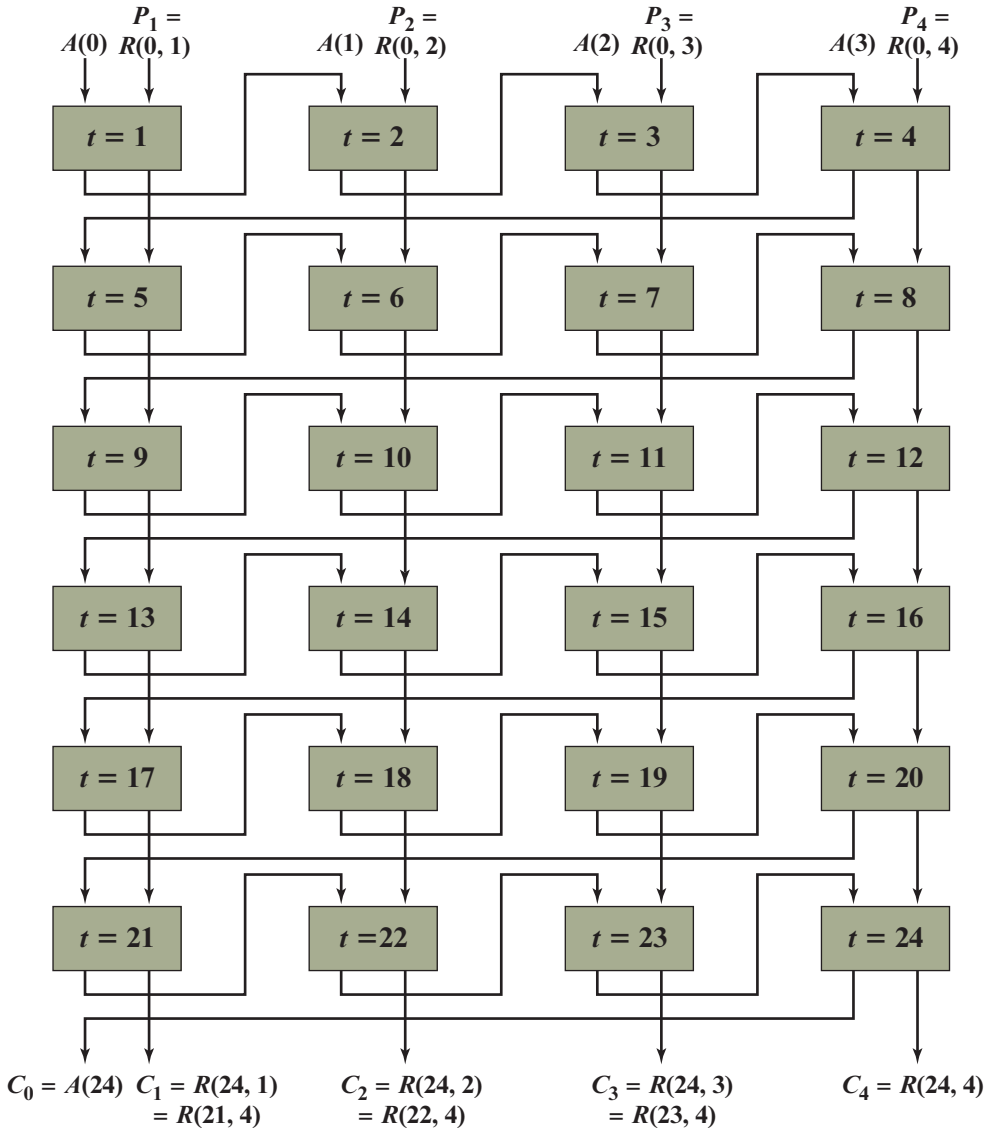

Figure 12.12 Key Wrapping Operation for 256-Bit Key

1. Initialize variables.

$A(s) = C_0$
for $i = 1$ **to** n
 $R(s, i) = C_i$

2. Calculate intermediate values.

for $t = s$ **to** 1
 $W = D(K, [(A(t) \oplus t) \parallel R(t, n)])$

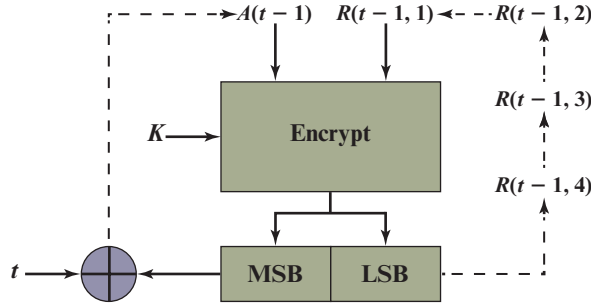

Figure 12.13 Key Wrapping Operation for 256-Bit Key: Stage t

```

A( $t-1$ ) = MSB64( $W$ )
R( $t-1, 1$ ) = LSB64( $W$ )
for  $i = 2$  to  $n$ 
    R( $t-1, i$ ) = R( $t, i-1$ )

```

3. Output results.

```

if A(0) = A6A6A6A6A6A6A6A6
then
    for  $i = 1$  to  $n$ 
        P( $i$ ) = R(0,  $i$ )
else
    return error

```

Note that the decryption function is used in the unwrapping algorithm.

We now demonstrate that the unwrap function is the inverse of the wrap function, that is, that the unwrap function recovers the plaintext key and the ICV. First, note that because the index variable t is counted down from s to 1 for unwrapping, stage t of the unwrap algorithm corresponds to stage t of the wrap algorithm. The input variables to stage t of the wrap algorithm are indexed at $t-1$ and the output variables of stage t of the unwrap algorithm are indexed at $t-1$. Thus, to demonstrate that the two algorithms are inverses of each other, we need only demonstrate that the output variables of stage t of the unwrap algorithm are equal to the input variables to stage t of the wrap algorithm.

This demonstration is in two parts. First we demonstrate that the calculation of A and R variables prior to the **for** loop are inverses. To do this, let us simplify the notation a bit. Define the 128-bit value T to be the 64-bit value t followed by 64 zeros. Then, the first three lines of step 2 of the wrap algorithm can be written as the following single line:

$$A(t) \| R(t, n) = T \oplus E(K, [A(t-1) \| R(t-1, 1)]) \quad (12.1)$$

The first three lines of step 2 of the unwrap algorithm can be written as:

$$A(t-1) \| R(t-1, 1) = D(K, ([A(t) \| R(t, n)] \oplus T)) \quad (12.2)$$

Expanding the right-hand side by substituting from Equation 12.1,

$$D(K, ([A(t) \| R(t, n)] \oplus T)) = D(K, ([T \oplus E(K, [A(t-1) \| R(t-1, 1)])] \oplus T))$$

Now we recognize that $T \oplus T = 0$ and that for any x , $x \oplus 0 = x$. So,

$$\begin{aligned} D(K, ([A(t) \| R(t, n)] \oplus T)) &= D(K, ([E(K, [A(t-1) \| R(t-1, 1)])]) \\ &= A(t-1) \| R(t-1, 1) \end{aligned}$$

The second part of the demonstration is to show that the **for** loops in step 2 of the wrap and unwrap algorithms are inverses. For stage k of the wrap algorithm, the variables $R(t-1, 1)$ through $R(t-1, n)$ are input. $R(t-1, 1)$ is used in the encryption calculation. $R(t-1, 2)$ through $R(t-1, n)$ are mapped, respectively into $R(t, 1)$ through $R(t, n-1)$, and $R(t, n)$ is output from the encryption function. For stage k of the unwrap algorithm, the variables $R(t, 1)$ through $R(t, n)$ are input. $R(t, n)$ is input to the decryption function to produce $R(t-1, 1)$. The remaining variables $R(t-1, 2)$ through $R(t-1, n)$ are generated by the **for** loop, such that they are mapped, respectively, from $R(t, 1)$ through $R(t, n-1)$.

Thus, we have shown that the output variables of stage k of the unwrap algorithm equal the input variables of stage k of the wrap algorithm.

12.9 PSEUDORANDOM NUMBER GENERATION USING HASH FUNCTIONS AND MACs

The essential elements of any pseudorandom number generator (PRNG) are a seed value and a deterministic algorithm for generating a stream of pseudorandom bits. If the algorithm is used as a pseudorandom function (PRF) to produce a required value, such as a session key, then the seed should only be known to the user of the PRF. If the algorithm is used to produce a stream encryption function, then the seed has the role of a secret key that must be known to the sender and the receiver.

We noted in Chapters 8 and 10 that, because an encryption algorithm produces an apparently random output, it can serve as the basis of a (PRNG). Similarly, a hash function or MAC produces apparently random output and can be used to build a PRNG. Both ISO standard 18031 (*Random Bit Generation*) and NIST SP 800-90 (*Recommendation for Random Number Generation Using Deterministic Random Bit Generators*) define an approach for random number generation using a cryptographic hash function. SP 800-90 also defines a random number generator based on HMAC. We look at these two approaches in turn.

PRNG Based on Hash Function

Figure 12.14a shows the basic strategy for a hash-based PRNG specified in SP 800-90 and ISO 18031. The algorithm takes as input:

V = seed

$seedlen$ = bit length of $V \geq K + 64$, where k is a desired security level expressed in bits

n = desired number of output bits

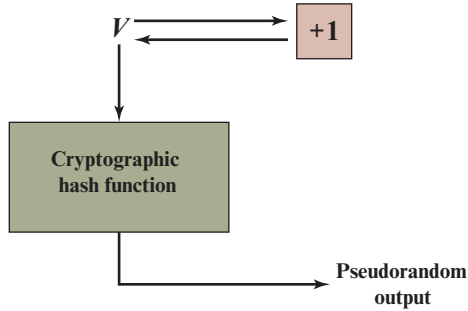

(a) PRNG using cryptographic hash function

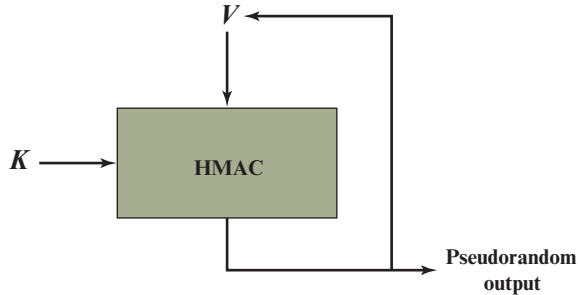

(b) PRNG using HMAC

Figure 12.14 Basic Structure of Hash-Based PRNGs (SP 800-90)

The algorithm uses the cryptographic hash function H with an hash value output of $outlen$ bits. The basic operation of the algorithm is

```

 $m = \lceil n/outlen \rceil$ 
 $data = V$ 
 $W = \text{the null string}$ 
For  $i = 1$  to  $m$ 
     $w_i = H(data)$ 
     $W = W \parallel w_i$ 
 $data = (data + 1) \bmod 2^{seedlen}$ 
Return leftmost  $n$  bits of  $W$ 

```

Thus, the pseudorandom bit stream is $w_1 \parallel w_2 \parallel \dots \parallel w_m$ with the final block truncated if required.

The SP 800-90 specification also provides for periodically updating V to enhance security. The specification also indicates that there are no known or suspected weaknesses in the hash-based approach for a strong cryptographic hash algorithm, such as SHA-2.

PRNG Based on MAC Function

Although there are no known or suspected weaknesses in the use of a cryptographic hash function for a PRNG in the manner of Figure 12.14a, a higher degree of confidence can be achieved by using a MAC. Almost invariably, HMAC is used for constructing a MAC-based PRNG. This is because HMAC is a widely used standardized MAC function and is implemented in many protocols and applications. As SP 800-90 points out, the disadvantage of this approach compared to the hash-based approach is that the execution time is twice as long, because HMAC involves two executions of the underlying hash function for each output block. The advantage of the HMAC approach is that it provides a greater degree of confidence in its security, compared to a pure hash-based approach.

For the MAC-based approach, there are two inputs: a key K and a seed V . In effect, the combination of K and V form the overall seed for the PRNG specified in SP 800-90. Figure 12.14b shows the basic structure of the PRNG mechanism, and the leftmost column of Figure 12.15 shows the logic. Note that the key remains the same for each block of output, and the data input for each block is equal to the tag output of the previous block. The SP 800-90 specification also provides for periodically updating K and V to enhance security.

It is instructive to compare the SP 800-90 recommendation with the use of HMAC for a PRNG in some applications, and this is shown in Figure 12.15. For the IEEE 802.11i wireless LAN security standard (Chapter 20), the data input consists of the seed concatenated with a counter. The counter is incremented for each block w_i of output. This approach would seem to offer enhanced security compared to the SP 800-90 approach. Consider that for SP 800-90, the data input for output block w_i is just the output w_{i-1} of the previous execution of HMAC. Thus, an opponent who is able to observe the pseudorandom output knows both the input and output of HMAC. Even so, with the assumption that HMAC is secure, knowledge of the input and output should not be sufficient to recover K and hence not sufficient to predict future pseudorandom bits.

The approach taken by the Transport Layer Security protocol (Chapter 19) and the Wireless Transport Layer Security Protocol (Chapter 20) involves invoking HMAC twice for each block of output w_i . As with IEEE 802.11, this is done in such a way that the output does not yield direct information about the input. The double use of HMAC doubles the execution burden and would seem to be security overkill.

$m = \lceil n/outlen \rceil$ $w_0 = V$ $W = \text{the null string}$ For $i = 1$ to m $w_i = \text{MAC}(K, w_{i-1})$ $W = W w_i$ Return leftmost n bits of W	$m = \lceil n/outlen \rceil$ $W = \text{the null string}$ For $i = 1$ to m $w_i = \text{MAC}(K, (V i))$ $W = W w_i$ Return leftmost n bits of W	$m = \lceil n/outlen \rceil$ $A(0) = V$ $W = \text{the null string}$ For $i = 1$ to m $A(i) = \text{MAC}(K, A(i - 1))$ $w_i = \text{MAC}(K, (A(i) V))$ $W = W w_i$ Return leftmost n bits of W
NIST SP 800-90	IEEE 802.11i	TLS/WTLS

Figure 12.15 Three PRNGs Based on HMAC

12.10 KEY TERMS, REVIEW QUESTIONS, AND PROBLEMS

Key Terms

authenticator cryptographic checksum	cryptographic hash function key wrapping	message authentication message authentication code (MAC)
---	--	--

Review Questions

- 12.1 What types of attacks are addressed by message authentication?
- 12.2 In general, a MAC function is a many-to-one function. Justify this statement. State one point of difference between a MAC function and encryption.
- 12.3 What are some approaches to producing message authentication?
- 12.4 When sending a message to B, A can use A's private key and B's public key to achieve both secrecy and authentication. Which key is used to achieve which goal?
- 12.5 What is a message authentication code?
- 12.6 What is the difference between a message authentication code and a one-way hash function?
- 12.7 In what ways can a hash value be secured so as to provide message authentication?
- 12.8 Is it necessary to recover the secret key in order to attack a MAC algorithm?
- 12.9 What is the advantage and disadvantage of the HMAC approach used for PRNG, compared to a pure hash-based approach?

Problems

- 12.1 An error-detection function can be used to compute a frame check sequence (FCS) or checksum (Figure 12.2). The FCS can provide error-detection capability to detect whether any bit of the transmitted message is altered. We could append the FCS to each message before encryption (Figure 12.2a), which is referred to as internal error control. Alternatively, we could append the FCS to each message after encryption (Figure 12.2b), which is referred to as external error control. With internal error control, authentication is provided because an opponent would have difficulty generating ciphertext that would have valid error control bits when it is decrypted. Will the FCS still provide authentication to the message if external error control is used?
- 12.2 The data authentication algorithm (DAA) based on DES with an initialization vector IV of zero (Figure 12.7) has been discovered to have security weaknesses. It is being replaced by newer and stronger algorithms. Show that the DAA cannot be trusted.
- 12.3 Section 12.6 mentions that a refined CMAC using two additional b -bit keys, K_1 and K_2 , is derived from the k -bit encryption key. Describe how you would generate K_1 and K_2 .

- 12.4** In this problem, we demonstrate that for CMAC, a variant that XORs the second key after applying the final encryption doesn't work. Let us consider this for the case of the message being an integer multiple of the block size. Then, the variant can be expressed as $\text{VMAC}(K, M) = \text{CBC}(K, M) \oplus K_1$. Now suppose an adversary is able to ask for the MACs of three messages: the message $\mathbf{0} = 0^n$, where n is the cipher block size; the message $\mathbf{1} = 1^n$; and the message $\mathbf{1} \parallel \mathbf{0}$. As a result of these three queries, the adversary gets $T_0 = \text{CBC}(K, \mathbf{0}) \oplus K_1$; $T_1 = \text{CBC}(K, \mathbf{1}) \oplus K_1$ and $T_2 = \text{CBC}(K, [\text{CBC}(K, \mathbf{1})]) \oplus K_1$. Show that the adversary can compute the correct MAC for the (unqueried) message $\mathbf{0} \parallel (T_0 \oplus T_1)$.
- 12.5** In the discussion of subkey generation in CMAC, it states that the block cipher is applied to the block that consists entirely of 0 bits. The first subkey is derived from the resulting string by a left shift of one bit and, conditionally, by XORing a constant that depends on the block size. The second subkey is derived in the same manner from the first subkey.
- What constants are needed for block sizes of 192 bits and 256 bits?
 - Explain how the left shift and XOR accomplishes the desired result.
- 12.6** Section 12.7 listed four general approaches to provide confidentiality and message encryption: $H \rightarrow E$, $A \rightarrow E$, $E \rightarrow A$, and $E + A$.
- Which of the above performs decryption before verification?
 - Which of the above performs verification before decryption?
- 12.7** Show that the GHASH function calculates

$$(X_1 \cdot H^m) \oplus (X_2 \cdot H^{m-1}) \oplus \cdots \oplus (X_{m-1} \cdot H^2) \oplus (X_m \cdot H)$$

- 12.8** Draw a figure similar to Figure 12.11 that shows authenticated decryption.
- 12.9** Alice wants to send a single bit of information (a yes or a no) to Bob by means of a word of length 2. Alice and Bob have four possible keys available to perform message authentication. The following matrix shows the 2-bit word sent for each message under each key:

	Message	
Key	0	1
1	00	11
2	01	10
3	10	01
4	11	00

- The preceding matrix is in a useful form for Alice. Construct a matrix with the same information that would be more useful for Bob.
 - What is the probability that someone else can successfully impersonate Alice?
 - What is the probability that someone can replace an intercepted message with another message successfully?
- 12.10** Draw figures similar to Figures 12.12 and 12.13 for the unwrap algorithm.

12.11 Consider the following key wrapping algorithm:

1. Initialize variables.

```

A = A6A6A6A6A6A6A6A6
for i = 1 to n
    R(i) = Pi

```

2. Calculate intermediate values.

```

for j = 0 to 5
    for i = 1 to n
        B = E(K, [A || R(i)])
        t = (n × j) + i
        A = t ⊕ MSB64(B)
        R(i) = LSB64(B)

```

3. Output results.

```

C0 = A
for i = 1 to n
    Ci = R(i)

```

- a. Compare this algorithm, functionally, with the algorithm specified in SP 800-38F and described in Section 12.8.
- b. Write the corresponding unwrap algorithm.

CHAPTER 13

DIGITAL SIGNATURES

13.1 Digital Signatures

- Properties
- Attacks and Forgeries
- Digital Signature Requirements
- Direct Digital Signature

13.2 ElGamal Digital Signature Scheme

13.3 Schnorr Digital Signature Scheme

13.4 NIST Digital Signature Algorithm

- The DSA Approach
- The Digital Signature Algorithm

13.5 Elliptic Curve Digital Signature Algorithm

- Global Domain Parameters
- Key Generation
- Digital Signature Generation and Authentication

13.6 RSA-PSS Digital Signature Algorithm

- Mask Generation Function
- The Signing Operation
- Signature Verification

13.7 Key Terms, Review Questions, and Problems

LEARNING OBJECTIVES

After studying this chapter, you should be able to:

- ◆ Present an overview of the digital signature process.
- ◆ Understand the ElGamal digital signature scheme.
- ◆ Understand the Schnorr digital signature scheme.
- ◆ Understand the NIST digital signature scheme.
- ◆ Compare and contrast the NIST digital signature scheme with the ElGamal and Schnorr digital signature schemes.
- ◆ Understand the elliptic curve digital signature scheme.
- ◆ Understand the RSA-PSS digital signature scheme.

The most important development from the work on public-key cryptography is the digital signature. The digital signature provides a set of security capabilities that would be difficult to implement in any other way.

Figure 13.1 is a generic model of the process of constructing and using digital signatures. All of the digital signature schemes discussed in this chapter have this structure. Suppose that Bob wants to send a message to Alice. Although it is not important that the message be kept secret, he wants Alice to be certain that the message is indeed from him. For this purpose, Bob uses a secure hash function, such as SHA-512, to generate a hash value for the message. That hash value, together with Bob's private key serves as input to a digital signature generation algorithm, which produces a short block that functions as a **digital signature**. Bob sends the message with the signature attached. When Alice receives the message plus signature, she (1) calculates a hash value for the message; (2) provides the hash value and Bob's public key as inputs to a digital signature verification algorithm. If the algorithm returns the result that the signature is valid, Alice is assured that the message must have been signed by Bob. No one else has Bob's private key and therefore no one else could have created a signature that could be verified for this message with Bob's public key. In addition, it is impossible to alter the message without access to Bob's private key, so the message is authenticated both in terms of source and in terms of data integrity.

We begin this chapter with an overview of digital signatures. We then present the ElGamal and Schnorr digital signature schemes, understanding of which makes it easier to understand the NIST Digital Signature Algorithm (DSA). The chapter then covers the two other important standardized digital signature schemes: the Elliptic Curve Digital Signature Algorithm (ECDSA) and the RSA Probabilistic Signature Scheme (RSA-PSS).

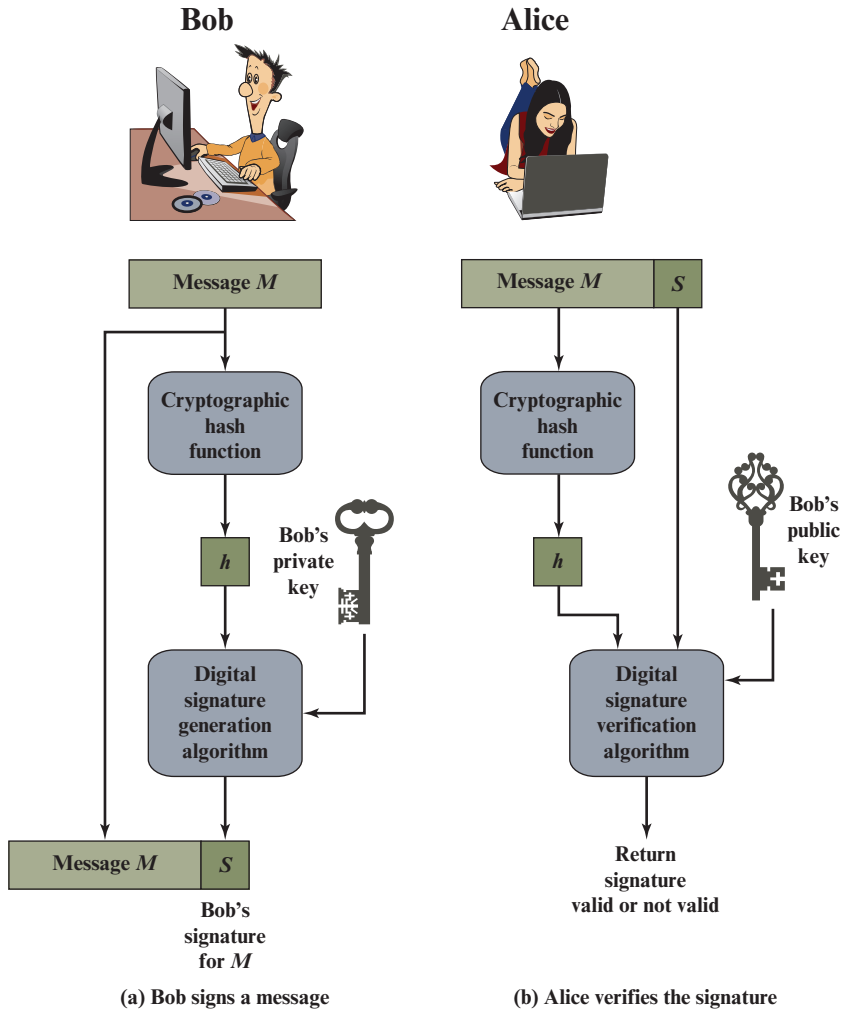

Figure 13.1 Simplified Depiction of Essential Elements of Digital Signature Process

13.1 DIGITAL SIGNATURES

Properties

Message authentication protects two parties who exchange messages from any third party. However, it does not protect the two parties against each other. Several forms of dispute between the two parties are possible.

For example, suppose that John sends an authenticated message to Mary, using one of the schemes of Figure 12.1. Consider the following disputes that could arise.

1. Mary may forge a different message and claim that it came from John. Mary would simply have to create a message and append an authentication code using the key that John and Mary share.
2. John can deny sending the message. Because it is possible for Mary to forge a message, there is no way to prove that John did in fact send the message.

Both scenarios are of legitimate concern. Here is an example of the first scenario: An electronic funds transfer takes place, and the receiver increases the amount of funds transferred and claims that the larger amount had arrived from the sender. An example of the second scenario is that an electronic mail message contains instructions to a stockbroker for a transaction that subsequently turns out badly. The sender pretends that the message was never sent.

In situations where there is not complete trust between sender and receiver, something more than authentication is needed. The most attractive solution to this problem is the digital signature. The digital signature must have the following properties:

- It must verify the author and the date and time of the signature.
- It must authenticate the contents at the time of the signature.
- It must be verifiable by third parties, to resolve disputes.

Thus, the digital signature function includes the authentication function.

Attacks and Forgeries

[GOLD88] lists the following types of attacks, in order of increasing severity. Here A denotes the user whose signature method is being attacked, and C denotes the attacker.

- **Key-only attack:** C only knows A's public key.
- **Known message attack:** C is given access to a set of messages and their signatures.
- **Generic chosen message attack:** C chooses a list of messages before attempting to break A's signature scheme, independent of A's public key. C then obtains from A valid signatures for the chosen messages. The attack is generic, because it does not depend on A's public key; the same attack is used against everyone.
- **Directed chosen message attack:** Similar to the generic attack, except that the list of messages to be signed is chosen after C knows A's public key but before any signatures are seen.
- **Adaptive chosen message attack:** C is allowed to use A as an "oracle." This means that C may request from A signatures of messages that depend on previously obtained message-signature pairs.

[GOLD88] then defines success at breaking a signature scheme as an outcome in which C can do any of the following with a non-negligible probability:

- **Total break:** C determines A's private key.
- **Universal forgery:** C finds an efficient signing algorithm that provides an equivalent way of constructing signatures on arbitrary messages.
- **Selective forgery:** C forges a signature for a particular message chosen by C.
- **Existential forgery:** C forges a signature for at least one message. C has no control over the message. Consequently, this forgery may only be a minor nuisance to A.

Digital Signature Requirements

On the basis of the properties and attacks just discussed, we can formulate the following requirements for a digital signature.

- The signature must be a bit pattern that depends on the message being signed.
- The signature must use some information only known to the sender to prevent both forgery and denial.
- It must be relatively easy to produce the digital signature.
- It must be relatively easy to recognize and verify the digital signature.
- It must be computationally infeasible to forge a digital signature, either by constructing a new message for an existing digital signature or by constructing a fraudulent digital signature for a given message.
- It must be practical to retain a copy of the digital signature in storage.

A secure hash function, embedded in a scheme such as that of Figure 13.1, provides a basis for satisfying these requirements. However, care must be taken in the design of the details of the scheme.

Direct Digital Signature

The term **direct digital signature** refers to a digital signature scheme that involves only the communicating parties (source, destination). It is assumed that the destination knows the public key of the source.

Confidentiality can be provided by encrypting the entire message plus signature with a shared secret key (symmetric encryption). Note that it is important to perform the signature function first and then an outer confidentiality function. In case of dispute, some third party must view the message and its signature. If the signature is calculated on an encrypted message, then the third party also needs access to the decryption key to read the original message. However, if the signature is the inner operation, then the recipient can store the plaintext message and its signature for later use in dispute resolution.

The validity of the scheme just described depends on the security of the sender's private key. If a sender later wishes to deny sending a particular message, the sender can claim that the private key was lost or stolen and that someone else forged his or her signature. Administrative controls relating to the security of private keys

can be employed to thwart or at least weaken this ploy, but the threat is still there, at least to some degree. One example is to require every signed message to include a **timestamp** (date and time) and to require prompt reporting of compromised keys to a central authority.

Another threat is that a private key might actually be stolen from X at time T . The opponent can then send a message signed with X 's signature and stamped with a time before or equal to T .

The universally accepted technique for dealing with these threats is the use of a digital certificate and certificate authorities. We defer a discussion of this topic until Chapter 14, and focus in this chapter on digital signature algorithms.

13.2 ELGAMAL DIGITAL SIGNATURE SCHEME

Before examining the NIST Digital Signature Algorithm, it will be helpful to understand the ElGamal and Schnorr signature schemes. Recall from Chapter 10, that the ElGamal encryption scheme is designed to enable encryption by a user's public key with decryption by the user's private key. The ElGamal signature scheme involves the use of the private key for digital signature generation and the public key for digital signature verification [ELGA84, ELGA85].

Before proceeding, we need a result from number theory. Recall from Chapter 2 that for a prime number q , if α is a primitive root of q , then

$$\alpha, \alpha^2, \dots, \alpha^{q-1}$$

are distinct (mod q). It can be shown that, if α is a primitive root of q , then

1. For any integer m , $\alpha^m \equiv 1 \pmod{q}$ if and only if $m \equiv 0 \pmod{q-1}$.
2. For any integers i, j , $\alpha^i \equiv \alpha^j \pmod{q}$ if and only if $i \equiv j \pmod{q-1}$.

As with ElGamal encryption, the global elements of **ElGamal digital signature** are a prime number q and α , which is a primitive root of q . User A generates a private/public key pair as follows.

1. Generate a random integer X_A , such that $1 < X_A < q - 1$.
2. Compute $Y_A = \alpha^{X_A} \pmod{q}$.
3. A 's private key is X_A ; A 's public key is $\{q, \alpha, Y_A\}$.

To sign a message M , user A first computes the hash $m = H(M)$, such that m is an integer in the range $0 \leq m \leq q - 1$. A then forms a digital signature as follows.

1. Choose a random integer K such that $1 \leq K \leq q - 1$ and $\gcd(K, q - 1) = 1$. That is, K is relatively prime to $q - 1$.
2. Compute $S_1 = \alpha^K \pmod{q}$. Note that this is the same as the computation of C_1 for ElGamal encryption.
3. Compute $K^{-1} \pmod{q-1}$. That is, compute the inverse of K modulo $q - 1$.
4. Compute $S_2 = K^{-1}(m - X_A S_1) \pmod{q-1}$.
5. The signature consists of the pair (S_1, S_2) .

Any user B can verify the signature as follows.

1. Compute $V_1 = \alpha^m \bmod q$.
2. Compute $V_2 = (Y_A)^{S_1}(S_1)^{S_2} \bmod q$.

The signature is valid if $V_1 = V_2$. Let us demonstrate that this is so. Assume that the equality is true. Then we have

$$\begin{array}{ll} \alpha^m \bmod q = (Y_A)^{S_1}(S_1)^{S_2} \bmod q & \text{assume } V_1 = V_2 \\ \alpha^m \bmod q = \alpha^{X_A S_1} \alpha^{K S_2} \bmod q & \text{substituting for } Y_A \text{ and } S_1 \\ \alpha^{m - X_A S_1} \bmod q = \alpha^{K S_2} \bmod q & \text{rearranging terms} \\ m - X_A S_1 \equiv K S_2 \pmod{q - 1} & \text{property of primitive roots} \\ m - X_A S_1 \equiv K K^{-1} (m - X_A S_1) \pmod{q - 1} & \text{substituting for } S_2 \end{array}$$

For example, let us start with the prime field GF(19); that is, $q = 19$. It has primitive roots {2, 3, 10, 13, 14, 15}, as shown in Table 2.7. We choose $\alpha = 10$.

Alice generates a key pair as follows:

1. Alice chooses $X_A = 16$.
2. Then $Y_A = \alpha^{X_A} \bmod q = 10^{16} \bmod 19 = 4$.
3. Alice's private key is 16; Alice's public key is $\{q, \alpha, Y_A\} = \{19, 10, 4\}$.

Suppose Alice wants to sign a message with hash value $m = 14$.

1. Alice chooses $K = 5$, which is relatively prime to $q - 1 = 18$.
2. $S_1 = \alpha^K \bmod q = 10^5 \bmod 19 = 3$ (see Table 2.7).
3. $K^{-1} \bmod (q - 1) = 5^{-1} \bmod 18 = 11$.
4. $S_2 = K^{-1} (m - X_A S_1) \bmod (q - 1) = 11 (14 - (16)(3)) \bmod 18 = -374 \bmod 18 = 4$.

Bob can verify the signature as follows.

1. $V_1 = \alpha^m \bmod q = 10^{14} \bmod 19 = 16$.
2. $V_2 = (Y_A)^{S_1}(S_1)^{S_2} \bmod q = (4^3)(3^4) \bmod 19 = 5184 \bmod 19 = 16$.

Thus, the signature is valid because $V_1 = V_2$.

13.3 SCHNORR DIGITAL SIGNATURE SCHEME

As with the ElGamal digital signature scheme, the Schnorr signature scheme is based on discrete logarithms [SCHN89, SCHN91]. The Schnorr scheme minimizes the message-dependent amount of computation required to generate a signature. The main work for signature generation does not depend on the message and can be done during the idle time of the processor. The message-dependent part of the signature generation requires multiplying a $2n$ -bit integer with an n -bit integer.

The scheme is based on using a prime modulus p , with $p - 1$ having a prime factor q of appropriate size; that is, $p - 1 \equiv 0 \pmod{q}$. Typically, we use $p \approx 2^{1024}$ and $q \approx 2^{160}$. Thus, p is a 1024-bit number, and q is a 160-bit number, which is also the length of the SHA-1 hash value.

The first part of this scheme is the generation of a private/public key pair, which consists of the following steps.

1. Choose primes p and q , such that q is a prime factor of $p - 1$.
2. Choose an integer a , such that $a^q \equiv 1 \pmod{p}$. The values a , p , and q comprise a global public key that can be common to a group of users.
3. Choose a random integer s with $0 < s < q$. This is the user's private key.
4. Calculate $v = a^{-s} \pmod{p}$. This is the user's public key.

A user with private key s and public key v generates a signature as follows.

1. Choose a random integer r with $0 < r < q$ and compute $x = a^r \pmod{p}$. This computation is a preprocessing stage independent of the message M to be signed.
2. Concatenate the message with x and hash the result to compute the value e :

$$e = H(M \| x)$$

3. Compute $y = (r + se) \pmod{q}$. The signature consists of the pair (e, y) .

Any other user can verify the signature as follows.

1. Compute $x' = a^y v^e \pmod{p}$.
2. Verify that $e = H(M \| x')$.

To see that the verification works, observe that

$$x' \equiv a^y v^e \equiv a^y a^{-se} \equiv a^{y-se} \equiv a^r \equiv x \pmod{p}$$

Hence, $H(M \| x') = H(M \| x)$.

13.4 NIST DIGITAL SIGNATURE ALGORITHM

The National Institute of Standards and Technology (NIST) has published Federal Information Processing Standard FIPS 186, known as the **Digital Signature Algorithm (DSA)**. The DSA makes use of the Secure Hash Algorithm (SHA) described in Chapter 12. The DSA was originally proposed in 1991 and revised in 1993 in response to public feedback concerning the security of the scheme. There was a further minor revision in 1996. In 2000, an expanded version of the standard was issued as FIPS 186-2, subsequently updated to FIPS 186-3 in 2009, and FIPS 186-4 in 2013. This latest version also incorporates digital signature algorithms based on RSA and on elliptic curve cryptography. In this section, we discuss DSA.

The DSA Approach

The DSA uses an algorithm that is designed to provide only the digital signature function. Unlike RSA, it cannot be used for encryption or key exchange. Nevertheless, it is a public-key technique.

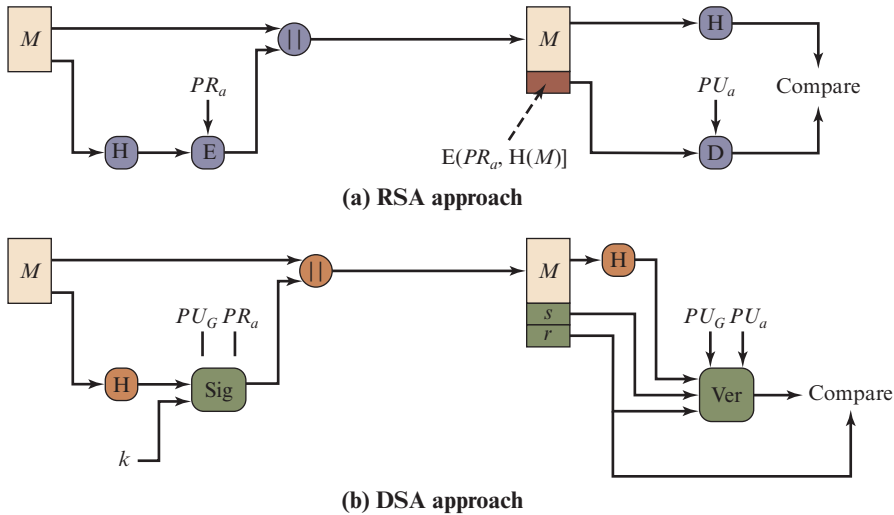

Figure 13.2 Two Approaches to Digital Signatures

Figure 13.2 contrasts the DSA approach for generating digital signatures to that used with RSA. In the RSA approach, the message to be signed is input to a hash function that produces a secure hash code of fixed length. This hash code is then encrypted using the sender's private key to form the signature. Both the message and the signature are then transmitted. The recipient takes the message and produces a hash code. The recipient also decrypts the signature using the sender's public key. If the calculated hash code matches the decrypted signature, the signature is accepted as valid. Because only the sender knows the private key, only the sender could have produced a valid signature.

The DSA approach also makes use of a hash function. The hash code is provided as input to a signature function along with a random number k generated for this particular signature. The signature function also depends on the sender's private key (PR_a) and a set of parameters known to a group of communicating principals. We can consider this set to constitute a global public key (PU_G).¹ The result is a signature consisting of two components, labeled s and r .

At the receiving end, the hash code of the incoming message is generated. The hash code and the signature are inputs to a verification function. The verification function also depends on the global public key as well as the sender's public key (PU_a), which is paired with the sender's private key. The output of the verification function is a value that is equal to the signature component r if the signature is valid. The signature function is such that only the sender, with knowledge of the private key, could have produced the valid signature.

We turn now to the details of the algorithm.

¹It is also possible to allow these additional parameters to vary with each user so that they are a part of a user's public key. In practice, it is more likely that a global public key will be used that is separate from each user's public key.

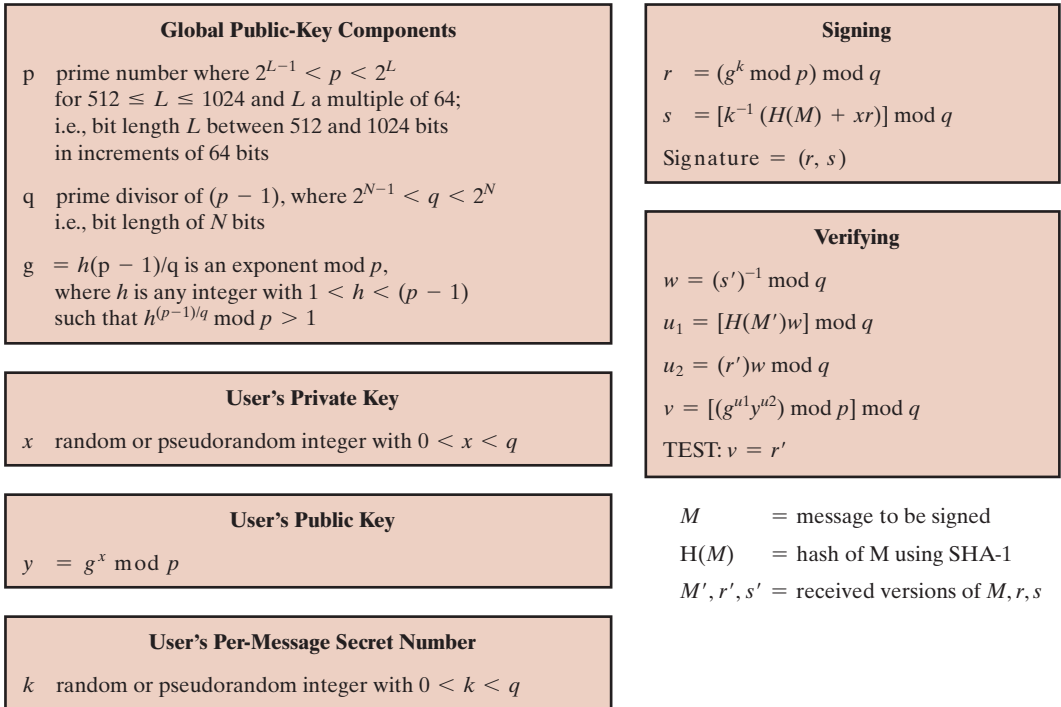

Figure 13.3 The Digital Signature Algorithm (DSA)

The Digital Signature Algorithm

DSA is based on the difficulty of computing discrete logarithms (see Chapter 2) and is based on schemes originally presented by ElGamal [ELGA85] and Schnorr [SCHN91].

Figure 13.3 summarizes the algorithm. There are three parameters that are public and can be common to a group of users. An N -bit prime number q is chosen. Next, a prime number p is selected with a length between 512 and 1024 bits such that q divides $(p - 1)$. Finally, g is chosen to be of the form $h^{(p-1)/q} \bmod p$, where h is an integer between 1 and $(p - 1)$ with the restriction that g must be greater than 1.² Thus, the global public-key components of DSA are the same as in the Schnorr signature scheme.

With these parameters in hand, each user selects a private key and generates a public key. The private key x must be a number from 1 to $(q - 1)$ and should be chosen randomly or pseudorandomly. The public key is calculated from the private key as $y = g^x \bmod p$. The calculation of y given x is relatively straightforward. However, given the public key y , it is believed to be computationally infeasible to determine x , which is the discrete logarithm of y to the base g , mod p (see Chapter 2).

²In number-theoretic terms, g is of order $q \bmod p$; see Chapter 2.

The signature of a message M consists of the pair of numbers r and s , which are functions of the public key components (p, q, g) , the user's private key (x) , the hash code of the message $H(M)$, and an additional integer k that should be generated randomly or pseudorandomly and be unique for each signing.

Let $M, r',$ and s' be the received versions of $M, r,$ and $s,$ respectively. Verification is performed using the formulas shown in Figure 13.3. The receiver generates a quantity v that is a function of the public key components, the sender's public key, the hash code of the incoming message, and the received versions of r and s . If this quantity matches the r component of the signature, then the signature is validated.

Figure 13.4 depicts the functions of signing and verifying.

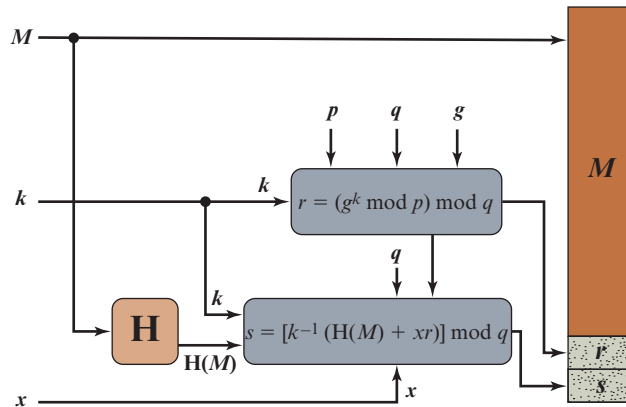

(a) Signing

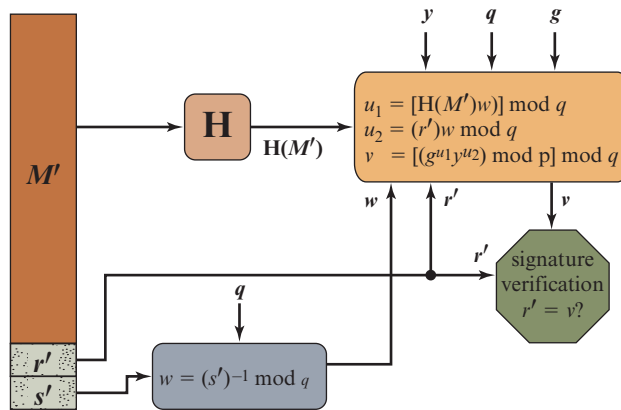

(b) Verifying

Figure 13.4 DSA Signing and Verifying

The structure of the algorithm, as revealed in Figure 13.4, is quite interesting. Note that the test at the end is on the value r , which does not depend on the message at all. Instead, r is a function of k and the three global public-key components. The multiplicative inverse of $k \pmod{q}$ is passed to a function that also has as inputs the message hash code and the user's private key. The structure of this function is such that the receiver can recover r using the incoming message and signature, the public key of the user, and the global public key. It is certainly not obvious from Figure 13.3 or Figure 13.4 that such a scheme would work. A proof is provided in FIPS 186-4.

Given the difficulty of taking discrete logarithms, it is infeasible for an opponent to recover k from r or to recover x from s .

Another point worth noting is that the only computationally demanding task in signature generation is the exponential calculation $g^k \pmod{p}$. Because this value does not depend on the message to be signed, it can be computed ahead of time. Indeed, a user could precalculate a number of values of r to be used to sign documents as needed. The only other somewhat demanding task is the determination of a multiplicative inverse, k^{-1} . Again, a number of these values can be precalculated.

13.5 ELLIPTIC CURVE DIGITAL SIGNATURE ALGORITHM

As was mentioned, the 2009 version of FIPS 186 includes a new digital signature technique based on elliptic curve cryptography, known as the **Elliptic Curve Digital Signature Algorithm (ECDSA)**. ECDSA is enjoying increasing acceptance due to the efficiency advantage of elliptic curve cryptography, which yields security comparable to that of other schemes with a smaller key bit length.

First we give a brief overview of the process involved in ECDSA. In essence, four elements are involved.

1. All those participating in the digital signature scheme use the same global domain parameters, which define an elliptic curve and a point of origin on the curve.
2. A signer must first generate a public, private key pair. For the private key, the signer selects a random or pseudorandom number. Using that random number and the point of origin, the signer computes another point on the elliptic curve. This is the signer's public key.
3. A hash value is generated for the message to be signed. Using the private key, the domain parameters, and the hash value, a signature is generated. The signature consists of two integers, r and s .
4. To verify the signature, the verifier uses as input the signer's public key, the domain parameters, and the integer s . The output is a value v that is compared to r . The signature is verified if $v = r$.

Let us examine each of these four elements in turn.

Global Domain Parameters

Recall from Chapter 10 that two families of elliptic curves are used in cryptographic applications: prime curves over Z_p and binary curves over $GF(2^m)$. For ECDSA, prime curves are used. The global domain parameters for ECDSA are the following:

- q a prime number
- a, b integers that specify the elliptic curve equation defined over Z_q with the equation $y^2 = x^3 + ax + b$
- G a base point represented by $G = (x_g, y_g)$ on the elliptic curve equation
- n order of point G ; that is, n is the smallest positive integer such that $nG = O$. This is also the number of points on the curve.

Key Generation

Each signer must generate a pair of keys, one private and one public. The signer, let us call him Bob, generates the two keys using the following steps:

1. Select a random integer $d, d \in [1, n - 1]$
2. Compute $Q = dG$. This is a point in $E_q(a, b)$
3. Bob's public key is Q and private key is d .

Digital Signature Generation and Authentication

With the public domain parameters and a private key in hand, Bob generates a digital signature of 320 bits for message m using the following steps:

1. Select a random or pseudorandom integer $k, k \in [1, n - 1]$
2. Compute point $P = (x, y) = kG$ and $r = x \bmod n$. If $r = 0$ then go to step 1
3. Compute $t = k^{-1} \bmod n$
4. Compute $e = H(m)$, where H is one of the SHA-2 or SHA-3 hash functions
5. Compute $s = k^{-1}(e + dr) \bmod n$. If $s = O$ then go to step 1
6. The signature of message m is the pair (r, s) .

Alice knows the public domain parameters and Bob's public key. Alice is presented with Bob's message and digital signature and verifies the signature using the following steps:

1. Verify that r and s are integers in the range 1 through $n - 1$
2. Using SHA, compute the 160-bit hash value $e = H(m)$
3. Compute $w = s^{-1} \bmod n$
4. Compute $u_1 = ew$ and $u_2 = rw$
5. Compute the point $X = (x_1, y_1) = u_1G + u_2Q$
6. If $X = O$, reject the signature else compute $v = x_1 \bmod n$
7. Accept Bob's signature if and only if $v = r$

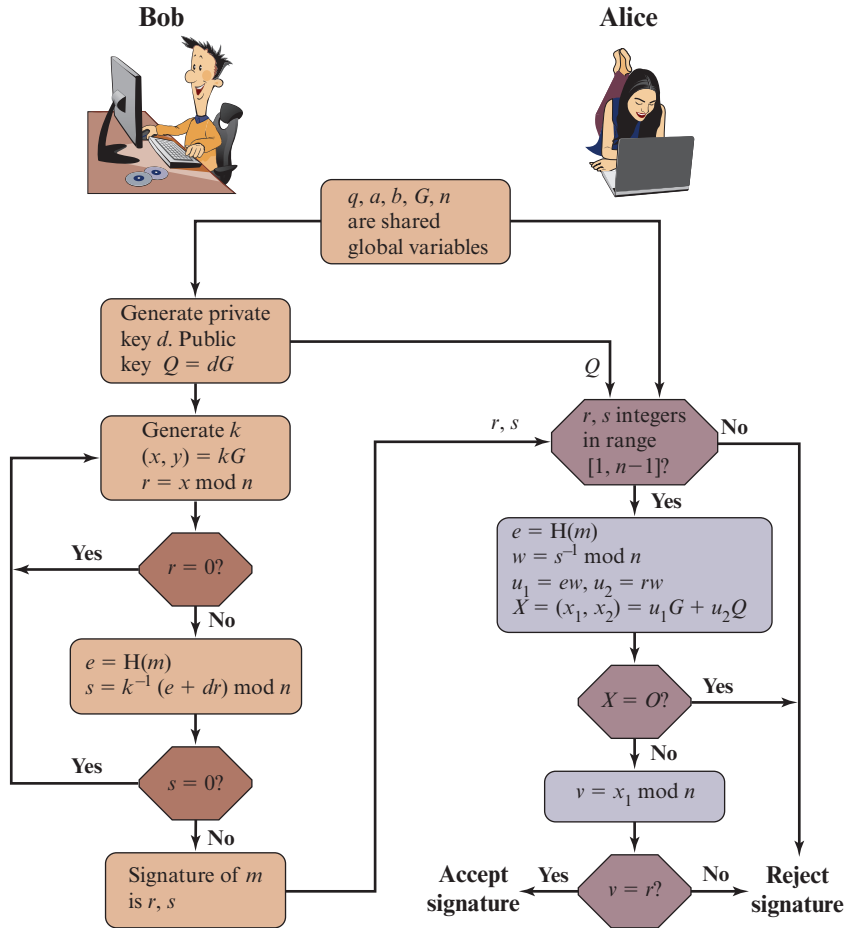

Figure 13.5 ECDSA Signing and Verifying

Figure 13.5 illustrates the signature authentication process. We can verify that this process is valid as follows. If the message received by Alice is in fact signed by Bob, then

$$s = k^{-1}(e + dr) \bmod n$$

Then

$$\begin{aligned} k &= s^{-1}(e + dr) \bmod n \\ k &= (s^{-1}e + s^{-1}dr) \bmod n \\ k &= (we + wdr) \bmod n \\ k &= (u_1 + u_2d) \bmod n \end{aligned}$$

Now consider that

$$u_1G + u_2Q = u_1G + u_2dG = (u_1 + u_2d)G = kG$$

In step 6 of the verification process, we have $v = x_1 \bmod n$, where point $X = (x_1, y_1) = u_1G + u_2Q$. Thus we see that $v = r$ since $r = x \bmod n$ and x is the x coordinate of the point kG and we have already seen that $u_1G + u_2Q = kG$.

13.6 RSA-PSS DIGITAL SIGNATURE ALGORITHM

In addition to the NIST Digital Signature Algorithm and ECDSA, the 2009 version of FIPS 186 also includes several techniques based on RSA, all of which were developed by RSA Laboratories and are in wide use. A worked-out example, using RSA, is available at this book's Web site.

In this section, we discuss the RSA Probabilistic Signature Scheme (RSA-PSS), which is the latest of the RSA schemes and the one that RSA Laboratories recommends as the most secure of the RSA schemes.

Because the RSA-based schemes are widely deployed in many applications, including financial applications, there has been great interest in demonstrating that such schemes are secure. The three main RSA signature schemes differ mainly in the padding format the signature generation operation employs to embed the hash value into a message representative, and in how the signature verification operation determines that the hash value and the message representative are consistent. For all of the schemes developed prior to PSS, it has not been possible to develop a mathematical proof that the signature scheme is as secure as the underlying RSA encryption/decryption primitive [KALI01]. The PSS approach was first proposed by Bellare and Rogaway [BELL96c, BELL98]. This approach, unlike the other RSA-based schemes, introduces a randomization process that enables the security of the method to be shown to be closely related to the security of the RSA algorithm itself. This makes RSA-PSS more desirable as the choice for RSA-based digital signature applications.

Mask Generation Function

Before explaining the RSA-PSS operation, we need to describe the mask generation function (MGF) used as a building block. $\text{MGF}(X, \text{maskLen})$ is a pseudorandom function that has as input parameters a bit string X of any length and the desired length L in octets of the output. MGFs are typically based on a secure cryptographic hash function such as SHA-1. An MGF based on a hash function is intended to be a cryptographically secure way of generating a message digest, or hash, of variable length based on an underlying cryptographic hash function that produces a fixed-length output.

The MGF function used in the current specification for RSA-PSS is MGF1, with the following parameters:

Options	Hash	hash function with output $hLen$ octets
Input	X	octet string to be masked
	maskLen	length in octets of the mask
Output	mask	an octet string of length maskLen

MGF1 is defined as follows:

1. Initialize variables.

```
T = empty string
k = ⌈maskLen/hLen⌉ - 1
```

2. Calculate intermediate values.

```
for counter = 0 to k
  Represent counter as a 32-bit string C
  T = T || Hash(X || C)
```

3. Output results.

```
mask = the leading maskLen octets of T
```

In essence, MGF1 does the following. If the length of the desired output is equal to the length of the hash value ($maskLen = hLen$), then the output is the hash of the input value X concatenated with a 32-bit counter value of 0. If $maskLen$ is greater than $hLen$, the MGF1 keeps iterating by hashing X concatenated with the counter and appending that to the current string T . So that the output is

$$\text{Hash}(X\|0)\|\text{Hash}(X\|1)\|\dots\|\text{Hash}(X\|k)$$

This is repeated until the length of T is greater than or equal to $maskLen$, at which point the output is the first $maskLen$ octets of T .

The Signing Operation

MESSAGE ENCODING The first stage in generating an RSA-PSS signature of a message M is to generate from M a fixed-length message digest, called an encoded message (EM). Figure 13.6 illustrates this process. We define the following parameters and functions:

Options	Hash	hash function with output $hLen$ octets. The current preferred alternative is SHA-1, which produces a 20-octet hash value.
	MGF	mask generation function. The current specification calls for MGF1.
	$sLen$	length in octets of a pseudorandom number referred to as the salt. Typically $sLen = hLen$, which for the current version is 20 octets.
Input	M	message to be encoded for signing.
	$emBits$	This value is one less than the length in bits of the RSA modulus n .
Output	EM	encoded message. This is the message digest that will be encrypted to form the digital signature.
Parameters	$emLen$	length of EM in octets = $\lceil emBits/8 \rceil$.
	padding ₁	hexadecimal string 00 00 00 00 00 00 00 00; that is, a string of 64 zero bits.

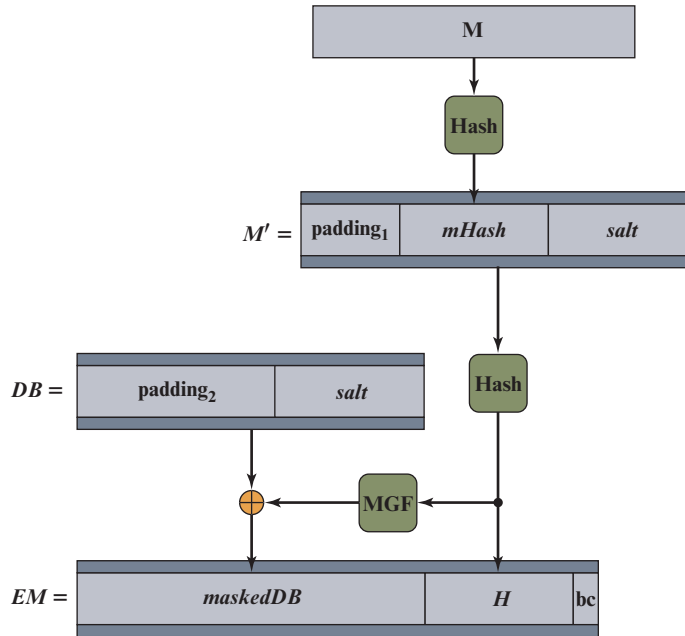

Figure 13.6 RSA-PSS Encoding

- $padding_2$ hexadecimal string of 00 octets with a length $(emLen - sLen - hLen - 2)$ octets, followed by the hexadecimal octet with value 01.
- $salt$ a pseudorandom number.
- bc the hexadecimal value BC.

The encoding process consists of the following steps.

1. Generate the hash value of M : $mHash = \text{Hash}(M)$
2. Generate a pseudorandom octet string $salt$ and form block $M' = padding_1 || mHash || salt$
3. Generate the hash value of M' : $H = \text{Hash}(M')$
4. Form data block $DB = padding_2 || salt$
5. Calculate the MGF value of H : $dbMask = \text{MGF}(H, emLen - hLen - 1)$
6. Calculate $maskedDB = DB \oplus dbMsk$
7. Set the leftmost $8emLen - emBits$ bits of the leftmost octet in $maskedDB$ to 0
8. $EM = maskedDB || H || 0xbc$

We make several comments about the complex nature of this message digest algorithm. All of the RSA-based standardized digital signature schemes involve appending one or more constants (e.g., $padding_1$ and $padding_2$) in the process of forming the message digest. The objective is to make it more difficult for an adversary to find another message that maps to the same message digest

as a given message or to find two messages that map to the same message digest. RSA-PSS also incorporates a pseudorandom number, namely the salt. Because the salt changes with every use, signing the same message twice using the same private key will yield two different signatures. This is an added measure of security.

FORMING THE SIGNATURE We now show how the signature is formed by a signer with private key $\{d, n\}$ and public key $\{e, n\}$ (see Figure 9.5). Treat the octet string EM as an unsigned, nonnegative binary integer m . The signature s is formed by encrypting m as follows:

$$s = m^d \bmod n$$

Let k be the length in octets of the RSA modulus n . For example if the key size for RSA is 2048 bits, then $k = 2048/8 = 256$. Then convert the signature value s into the octet string S of length k octets.

Signature Verification

DECRYPTION For signature verification, treat the signature S as an unsigned, nonnegative binary integer s . The message digest m is recovered by decrypting s as follows:

$$m = s^e \bmod n$$

Then, convert the message representative m to an encoded message EM of length $emLen = \lceil (modBits - 1)/8 \rceil$ octets, where $modBits$ is the length in bits of the RSA modulus n .

EM VERIFICATION EM verification can be described as follows:

Options	Hash	hash function with output $hLen$ octets.
	MGF	mask generation function.
	$sLen$	length in octets of the salt.
Input	M	message to be verified.
	EM	the octet string representing the decrypted signature, with length $emLen = \lceil emBits/8 \rceil$.
	$emBits$	This value is one less than the length in bits of the RSA modulus n .
Parameters	padding ₁	hexadecimal string 00 00 00 00 00 00 00 00; that is, a string of 64 zero bits.
	padding ₂	hexadecimal string of 00 octets with a length $(emLen - sLen - hLen - 2)$ octets, followed by the hexadecimal octet with value 01.

1. Generate the hash value of M : $mHash = \text{Hash}(M)$
2. If $emLen < hLen + sLen + 2$, output “inconsistent” and stop
3. If the rightmost octet of EM does not have hexadecimal value BC, output “inconsistent” and stop

4. Let $maskedDB$ be the leftmost $emLen - hLen - 1$ octets of EM , and let H be the next $hLen$ octets
5. If the leftmost $8emLen - emBits$ bits of the leftmost octet in $maskedDB$ are not all equal to zero, output “inconsistent” and stop
6. Calculate $dbMask = MGF(H, emLen - hLen - 1)$
7. Calculate $DB = maskedDB \oplus dbMask$
8. Set the leftmost $8emLen - emBits$ bits of the leftmost octet in DB to zero
9. If the leftmost $(emLen - hLen - sLen - 1)$ octets of DB are not equal to padding₂, output “inconsistent” and stop
10. Let $salt$ be the last $sLen$ octets of DB
11. Form block $M' = padding_1 || mHash || salt$
12. Generate the hash value of M' : $H' = Hash(M')$
13. If $H = H'$, output “consistent.” Otherwise, output “inconsistent”

Figure 13.7 illustrates the process. The shaded boxes labeled H and H' correspond, respectively, to the value contained in the decrypted signature and the value generated from the message M associated with the signature. The remaining three shaded areas contain values generated from the decrypted signature and compared to known constants. We can now see more clearly the different roles played by the constants and the pseudorandom value $salt$, all of which are embedded in the

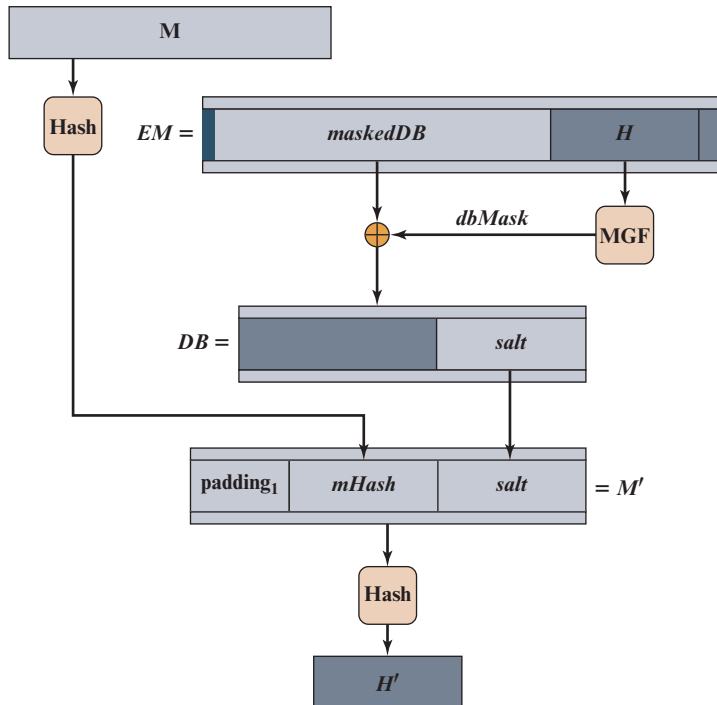

Figure 13.7 RSA-PSS EM Verification

EM generated by the signer. The constants are known to the verifier, so that the computed constants can be compared to the known constants as an additional check that the signature is valid (in addition to comparing H and H'). The salt results in a different signature every time a given message is signed with the same private key. The verifier does not know the value of the salt and does not attempt a comparison. Thus, the salt plays a similar role to the pseudorandom variable k in the NIST DSA and in ECDSA. In both of those schemes, k is a pseudorandom number generated by the signer, resulting in different signatures from multiple signings of the same message with the same private key. A verifier does not and need not know the value of k .

13.7 KEY TERMS, REVIEW QUESTIONS, AND PROBLEMS

Key Terms

digital signature Digital Signature Algorithm (DSA) direct digital signature	ElGamal digital signature Elliptic Curve Digital Signature Algorithm (ECDSA)	timestamp
---	---	-----------

Review Questions

- 13.1 List two disputes that can arise in the context of message authentication.
- 13.2 What are the properties a digital signature should have?
- 13.3 What requirements should a digital signature scheme satisfy?
- 13.4 What is the difference between direct and arbitrated digital signature?
- 13.5 In what order should the signature function and the confidentiality function be applied to a message, and why?
- 13.6 What are some threats associated with a direct digital signature scheme?

Problems

- 13.1 Dr. Watson patiently waited until Sherlock Holmes finished. “Some interesting problem to solve, Holmes?” he asked when Holmes finally logged out.

“Oh, not exactly. I merely checked my email and then made a couple of network experiments instead of my usual chemical ones. I have only one client now and I have already solved his problem. If I remember correctly, you once mentioned cryptology among your other hobbies, so it may interest you.”

“Well, I am only an amateur cryptologist, Holmes. But of course I am interested in the problem. What is it about?”

“My client is Mr. Hosgrave, director of a small but progressive bank. The bank is fully computerized and of course uses network communications extensively. The bank already uses RSA to protect its data and to digitally sign documents that are communicated. Now the bank wants to introduce some changes in its procedures; in particular, it needs to digitally sign some documents by *two* signatories.

1. The first signatory prepares the document, forms its signature, and passes the document to the second signatory.

2. The second signatory as a first step must verify that the document was really signed by the first signatory. She then incorporates her signature into the document's signature so that the recipient, as well as any member of the public, may verify that the document was indeed signed by both signatories. In addition, only the second signatory has to be able to verify the document's signature after the first step; that is, the recipient (or any member of the public) should be able to verify only the complete document with signatures of both signatories, but not the document in its intermediate form where only one signatory has signed it. Moreover, the bank would like to make use of its existing modules that support RSA-style digital signatures."

"Hm, I understand how RSA can be used to digitally sign documents by *one* signatory, Holmes. I guess you have solved the problem of Mr. Hosgrave by appropriate generalization of RSA digital signatures."

"Exactly, Watson," nodded Sherlock Holmes. "Originally, the RSA digital signature was formed by encrypting the document by the signatory's private decryption key 'd', and the signature could be verified by anyone through its decryption using publicly known encryption key 'e'. One can verify that the signature S was formed by the person who knows d, which is supposed to be the only signatory. Now the problem of Mr. Hosgrave can be solved in the same way by slight generalization of the process, that is ..."

Finish the explanation.

- 13.2 DSA specifies that if the signature generation process results in a value of $s = 0$, a new value of k should be generated and the signature should be recalculated. Why?
- 13.3 What happens if a k value used in creating a DSA signature is compromised?
- 13.4 The DSA document includes a recommended algorithm for testing a number for primality.
1. **[Choose w]** Let w be a random odd integer. Then $(w - 1)$ is even and can be expressed in the form $2^a m$ with m odd. That is, 2^a is the largest power of 2 that divides $(w - 1)$.
 2. **[Generate b]** Let b be a random integer in the range $1 < b < w$.
 3. **[Exponentiate]** Set $j = 0$ and $z = b^m \bmod w$.
 4. **[Done?]** If $j = 0$ and $z = 1$, or if $z = w - 1$, then w passes the test and may be prime; go to step 8.
 5. **[Terminate?]** If $j > 0$ and $z = 1$, then w is not prime; terminate algorithm for this w .
 6. **[Increase j]** Set $j = j + 1$. If $j < a$, set $z = z^2 \bmod w$ and go to step 4.
 7. **[Terminate]** w is not prime; terminate algorithm for this w .
 8. **[Test again?]** If enough random values of b have been tested, then accept w as prime and terminate algorithm; otherwise, go to step 2.
 - a. Explain how the algorithm works.
 - b. Show that it is equivalent to the Miller–Rabin test described in Chapter 2.
- 13.5 With DSA, because the value of k is generated for each signature, even if the same message is signed twice on different occasions, the signatures will differ. This is not true of RSA signatures. What is the practical implication of this difference?
- 13.6 Consider the problem of creating domain parameters for DSA. Suppose we have already found primes p and q such that $q \mid (p - 1)$. Now we need to find $g \in \mathbb{Z}_p$ with g of order $q \bmod p$. Consider the following two algorithms:

Algorithm 1	Algorithm 2
repeat	repeat
select $g \in \mathbb{Z}_p$	select $h \in \mathbb{Z}_p$
$h \leftarrow g^q \bmod p$	$g \leftarrow h^{(p-1)/q} \bmod p$
until ($h = 1$ and $g \neq 1$)	until ($g \neq 1$)
return g	return g

- a. What happens in Algorithm 1 if $\text{ord}(g) = q$ is chosen?
- b. What happens in Algorithm 2 if $\text{ord}(g) = q$ is chosen?
- c. Suppose $p = 64891$ and $q = 421$. How many loop iterations do you expect Algorithm 1 to make before it finds a generator?
- d. If p is 512 bits and q is 128 bits, would you recommend using Algorithm 1 to find g ? Explain.
- e. Suppose $p = 64891$ and $q = 421$. What is the probability that Algorithm 2 computes a generator in its very first loop iteration? (If it is helpful, you may use the fact that $\sum_{(d|n)} \psi(d) = n$ when answering this question.)

13.7 It is tempting to try to develop a variation on Diffie–Hellman that could be used as a digital signature. Here is one that is simpler than DSA and that does not require a secret random number in addition to the private key.

Public elements: q prime number
 α $\alpha < q$ and α is primitive root of q

Private key: X $X < q$

Public key: $Y = \alpha^X \bmod q \bmod q$

To sign a message M , compute $h = H(M)$, which is the hash code of the message. We require that $\text{gcd}(h, q - 1) = 1$. If not, append the hash to the message and calculate a new hash. Continue this process until a hash code is produced that is relatively prime to $(q - 1)$. Then, calculate Z to satisfy $Z \equiv X \times h \pmod{q - 1}$. The signature of the message is $\sigma = \alpha^Z$. To verify the signature, a user computes t such that $t \times h = 1 \pmod{q - 1}$ and verifies $Y = \sigma t \bmod q$.

- a. Show that this scheme works. That is, show that the verification process produces an equality if the signature is valid.
- b. Show that the scheme is unacceptable by describing a simple technique for forging a user's signature on an arbitrary message.

13.8 Assume a technique for a digital signature scheme using a cryptographic one-way hash function (H) as follows. To sign an n -bit message, the sender randomly generates in advance $2n$ 64-bit cryptographic keys: $k_1, k_2, \dots, k_n, k'_1, k'_2, \dots, k'_n$ which are kept private. The sender generates the following two sets of validation parameters, which are made public.

$$v_1, v_2, \dots, v_n \text{ and } v'_1, v'_2, \dots, v'_n$$

where

$$v_i = H(k_i \| 0), v'_i = H(k'_i \| 1)$$

The user sends the appropriate k_i or k'_i according to whether M_i is 0 or 1, respectively. For example, if the first 3 bits of the message are 011, then the first three keys of the signature are k_1, k'_2 , and k'_3 .

- a. How does the receiver validate the message?
- b. Is the technique secure?
- c. How many times can the same set of secret keys be safely used for different messages?
- d. What, if any, practical problems does this scheme present?

CHAPTER 14

LIGHTWEIGHT CRYPTOGRAPHY AND POST-QUANTUM CRYPTOGRAPHY

14.1 Lightweight Cryptography Concepts

- Embedded Systems
- Constrained Devices
- Categories of Constraints for Lightweight Cryptography
- Security Considerations for Various Applications
- Design Trade-Offs
- Security Requirements

14.2 Lightweight Cryptographic Algorithms

- Authenticated Encryption with Additional Data
- Hash Functions
- Message Authentication Codes
- Asymmetric Cryptographic Algorithms

14.3 Post-Quantum Cryptography Concepts

- Quantum Computing
- Shor's Factoring Algorithm
- Grover's Algorithm
- Cryptoperiods
- Quantum Safety

14.4 Post-Quantum Cryptographic Algorithms

- Lattice-Based Cryptographic Algorithms
- Code-Based Cryptographic Algorithms
- Multivariate-Based Cryptographic Algorithms
- Hash-Based Digital Signature Algorithms

14.5 Key Terms and Review Questions

LEARNING OBJECTIVES

After studying this chapter, you should be able to

- ◆ Explain the concept of embedded system.
- ◆ Explain the concept of constrained device.
- ◆ Give a presentation on the concept of lightweight cryptography and the types of cryptographic algorithms for which lightweight cryptography is of interest.
- ◆ Discuss the constraints that affect the design of lightweight cryptographic algorithms.
- ◆ Discuss the security requirements for lightweight cryptographic algorithms.
- ◆ Present an overview of approaches to lightweight cryptography for authenticated encryption, hash functions, and message authentication codes.
- ◆ Explain the need for post-quantum cryptographic algorithms and which types of algorithms are affected.
- ◆ Present an overview of mathematical approaches to developing post-quantum cryptographic algorithms.

Two recent areas of strong interest in the field of cryptography are lightweight cryptography and post-quantum cryptography. It is likely in the coming years that a number of new algorithms in both areas will be widely deployed. In essence, lightweight cryptography is focused on developing algorithms that, while secure, minimize execution time, memory usage, and power consumption. Such algorithms are suitable for small embedded systems such as those in wide use in the Internet of Things (IoT). Work on lightweight cryptography is almost exclusively devoted to symmetric (secret key) algorithms and cryptographic hash functions.

Post-quantum cryptography is an area of study that arises from the concern that quantum computers would be able to break currently used asymmetric cryptographic algorithms. Shor's algorithm demonstrated a feasible way to break asymmetric algorithms that rely on either integer factorization or discrete logarithms. Thus, work on post-quantum cryptography is devoted to developing new asymmetric cryptographic algorithms.

14.1 LIGHTWEIGHT CRYPTOGRAPHY CONCEPTS

Lightweight cryptography is a subfield of cryptography concerned with the development of cryptographic algorithms for resource-constrained devices. The term **lightweight** refers to the characteristic that a cryptographic algorithm makes minimal resource demands on the host system. For many existing cryptographic standards, the algorithms incorporate trade-offs between security, performance, and cost requirements that make them unsuitable for implementation in resource-constrained devices. Lightweight cryptography includes attempts to develop efficient implementations of conventional cryptographic algorithms as well as the design of new lightweight algorithms.

Embedded Systems

The term **embedded system** refers to the use of electronics and software within a product that has a specific function or set of functions, as opposed to a general-purpose computer, such as a laptop or desktop system. We can also define an embedded system as any device that includes a computer chip, but that is not a general-purpose workstation, desktop, or laptop computer. Hundreds of millions of computers are sold every year, including laptops, personal computers, workstations, servers, mainframes, and supercomputers. In contrast, tens of billions of microcontrollers are produced each year that are embedded within larger devices. Today, many, perhaps most, devices that use electric power have an embedded computing system. It is likely that in the near future, virtually all such devices will have embedded computing systems.

Types of devices with embedded systems are almost too numerous to list. Examples include cell phones, digital cameras, video cameras, calculators, microwave ovens, home security systems, washing machines, lighting systems, thermostats, printers, various automotive systems (e.g., transmission control, cruise control, fuel injection, anti-lock brakes, and suspension systems), tennis rackets, toothbrushes, and numerous types of sensors and actuators in automated systems.

MICROCONTROLLERS A **microcontroller** is a single chip that contains the processor, nonvolatile memory for the program (ROM or flash), volatile memory for input and output (RAM), a clock, and an I/O control unit. It is also called a “computer on a chip.” A microcontroller chip makes a substantially different use of the logic space available. The processor portion of the microcontroller has a much lower silicon area than other microprocessors and much higher energy efficiency.

Billions of microcontroller units are embedded each year in myriad products from toys to appliances to automobiles. For example, a single vehicle can use 70 or more microcontrollers. Typically, especially for the smaller, less expensive microcontrollers, they are used as dedicated processors for specific tasks. For example, microcontrollers are heavily utilized in automation processes. By providing simple reactions to input, they can control machinery, turn fans on and off, open and close valves, and so forth. They are integral parts of modern industrial technology and are among the most inexpensive ways to produce machinery that can handle extremely complex functionalities.

Microcontrollers come in a range of physical sizes and processing power. Processors range from 4-bit to 32-bit architectures. Microcontrollers tend to be much slower than microprocessors, typically operating in the MHz range rather than the GHz speeds of microprocessors. Another typical feature of a microcontroller is that it does not provide for human interaction. The microcontroller is programmed for a specific task, embedded in its device, and executes as and when required.

DEEPLY EMBEDDED SYSTEMS A subset of embedded systems, and a quite numerous subset, is referred to as **deeply embedded systems**. In general terms, a deeply embedded system has a processor whose behavior is difficult to observe both by the programmer and the user. A deeply embedded system uses a microcontroller, is not programmable once the program logic for the device has been burned into ROM (read-only memory), and has no interaction with a user.

Deeply embedded systems are dedicated, single-purpose devices that detect something in the environment, perform a basic level of processing, and then do something with the results. Deeply embedded systems often have wireless capability and appear in networked configurations, such as networks of sensors deployed over a large area (e.g., factory, agricultural field). The IoT depends heavily on deeply embedded systems. Typically, deeply embedded systems have extreme resource constraints in terms of memory, processor size, time, and power consumption.

Constrained Devices

A **constrained device** is a device with limited volatile and nonvolatile memory, limited processing power, and a low data rate transceiver. Many devices in the IoT, particularly the smaller, more numerous devices, are resource constrained. As pointed out in [SEGH12], technology improvements following Moore's law continue to make embedded devices cheaper, smaller, and more energy-efficient but not necessarily more powerful. Typical constrained devices are equipped with 8- or 16-bit microcontrollers that possess very little RAM and storage capacities. Resource-constrained devices are often equipped with an IEEE 802.15.4 radio, which enables low-power low-data-rate wireless personal area networks (WPANs) with data rates of 20–250 kbps and frame sizes of up to 127 octets.

RFC 7228 (Terminology for Constrained-Node Networks) defines three classes of constrained devices (Table 14.1):

- **Class 0:** These are very constrained devices, typically sensors, called *motes*, or *smart dust*. Motes can be implanted or scattered over a region to collect data and pass it on from one to another to some central collection point. For example, a farmer, vineyard owner, or ecologist could equip motes with sensors that detect temperature, humidity, etc., making each mote a mini weather station. Scattered throughout a field, vineyard or forest, these motes would allow the tracking of microclimates. Class 0 devices generally cannot be secured or managed comprehensively in the traditional sense. They will most likely be pre-configured (and will be reconfigured rarely, if at all) with a very small data set.
- **Class 1:** These are quite constrained in code space and processing capabilities, such that they cannot easily talk to other Internet nodes employing a full protocol stack. However, they are capable enough to use a protocol stack specifically designed for constrained nodes and participate in meaningful conversations without the help of a gateway node.
- **Class 2:** These are less constrained and fundamentally capable of supporting most of the same protocol stacks as used on notebooks or servers. However, they are still very constrained compared to high-end IoT devices. Thus, they require lightweight and energy-efficient protocols and low transmission traffic.

Table 14.1 Classes of Constrained Devices

Class	Data Size (RAM)	Code Size (flash, ROM)
Class 0	« 10 kB	« 100 kB
Class 1	~ 10 kB	~ 100 kB
Class 2	~ 50 kB	~ 250 kB

Categories of Constraints for Lightweight Cryptography

It is useful to define the specific constraints that relate to the design of **lightweight cryptographic algorithms**. ISO 29192-1 (*Lightweight Cryptography—Part 1: General*, June 2012) lists the following as the key constraints:

- **Chip area:** Chip area is of concern when a cryptographic algorithm is implemented in hardware. Very small devices, such as small sensors, have limited available chip area to provide for security. Typically, chip area is expressed in gate equivalents (GEs). The GE value is derived by dividing the area of the integrated circuit by the area of a two-input NAND gate in the appropriate technology.
- **Energy consumption:** Many constrained devices operate from a very small battery or energy derived from an incoming signal. Accordingly, algorithms may need to be designed to minimize energy consumption. Energy consumption is a function of several factors including the processing time, the chip area (when implemented in hardware), the operating frequency, and the number of bits transmitted between entities (in wireless transmissions in particular).
- **Program code size and RAM size:** Constrained devices typically have very limited space for program code (e.g., in ROM) and RAM needed for execution. Thus, cryptographic algorithms need to be compact in terms of code and make use of minimal RAM during execution.
- **Communications transmission rate:** Very constrained devices, such as sensors and RFID tags, may be capable of very limited data rates. Thus, the amount of security-related data that needs to be transmitted, such as message authentication codes and key exchange material, needs to be extremely small.
- **Execution time:** For some devices, such as contactless cards and RFID tags, execution time is constrained by the amount of time the device is present in the communication zone.

Security Considerations for Various Applications

Security requirements vary for different types of constrained devices. A useful list of application areas is defined by the CRYPTREC¹ Lightweight Cryptography Working Group in [CRYP17]. The following section summarizes key considerations for these devices.

RADIO-FREQUENCY IDENTIFICATION (RFID) RFID is a data collection technology that uses electronic tags attached to items to allow the items to be identified and tracked by a remote system. RFID technology is increasingly becoming an enabling technology for IoT. The main elements of an RFID system are tags and readers. RFID tags are small programmable devices, with an attached antenna, used for object, animal, and human tracking. They come in a variety of shapes, sizes, functionalities, and costs. RFID readers acquire and sometimes rewrite information stored on RFID tags that come within operating range (a few inches up to several feet). Readers are usually connected to a computer system that records and formats the acquired information for further uses.

¹CRYPTREC is the Cryptography Research and Evaluation Committee created by the Japanese Government to evaluate and recommend cryptographic techniques for government and industrial use.

RFID devices require cryptographic algorithms that use a very small amount of logic and memory. Despite this, depending on the use of the RFID tag, a number of security mechanisms may be required. [SAAR12] lists the following as example uses and the corresponding security requirements:

- **Counterfeit goods:** RFID tags can be cloned or modified in order for counterfeit products or parts to pass as genuine. Authentication can counter this threat.
- **Environmental logging:** Tampering with information such as temperature logs can pose a threat to the supply chain management of products such as fresh goods and medical supplies. Data and device authentication can counter this threat.
- **Privacy of Electronic Product Code (EPC):** The EPC is designed to be stored on an RFID tag and it provides a universal identifier for every physical object anywhere in the world. This raises serious privacy issues if such tags are attached to personal items. Therefore, the tag must also identify the reader as trusted before divulging traceable information.
- **Antitheft:** Data may be written to the tag to indicate to an exit portal whether or not that item has been sold. Persistent memory write and lock operations must be protected to prevent theft.
- **Returns:** When a tag is returned to a store or manufacturer, an authenticated reset/write mechanism allows it to be reused. The tags maintain some amount of persistent memory; read, write, and lock operations to this memory must be authenticated to prevent tamper and unauthorized modification. Authenticated reads allow data to be visible only for the tag's owner.

ELECTRONIC HOME APPLIANCES AND SMART TV A number of home appliances, including air conditioners, ovens, and televisions, are now equipped with embedded processors that provide a range of services and may be connected to the Internet. To lower cost, these embedded systems are generally very constrained and are almost constantly under full load, leaving limited resources for security features. These devices are vulnerable to unauthorized access that may tamper with the control signals or issue illegal commands that would lead to abnormal operations. These devices will also usually have updateable software. Thus, authentication methods are important.

SMART AGRICULTURAL SENSORS Environmental sensors in agricultural settings can improve productivity and yield. For example, the sensors can operate with actuators to control the timing and amount of watering and to automatically open and close greenhouse windows and to schedule pest control. Requirements for sensor networks include autonomously driven, small size, low power consumption, and low cost so that large numbers of sensors can be employed. These devices need to be tamper resistant to prevent sabotage.

MEDICAL SENSORS Wireless medical sensors permit health monitoring of patients outside of a hospital setting, capturing and transmitting a number of medical and health-related measures. These devices, particularly if that are implanted, are generally extremely small and use very little power.

INDUSTRIAL SYSTEMS In factories, the transportation, processing, and assembly operations have been automated to improve operational efficiency. Several machine

tools and robots can be connected by a network to share manufacturing information and to manage the processes based on the data collected by sensors. Through a network, it is also possible to store information at a single place and to manage the equipment from a central location.

When connected to the Internet, these systems can be vulnerable both to the exposure of data and to sabotage. The risk is especially high in the case of critical public infrastructure, such as power distribution systems, nuclear power plants, water treatment, and air traffic control. The execution of unauthorized commands or the failure to execute authorized commands can lead to significant and even catastrophic damage. Thus, authentication, authorization, and availability mechanism are essential.

AUTOMOBILES Modern automobiles provide both in-vehicle communication as well as wireless communication with external entities via small embedded systems. These onboard embedded devices are part of what are termed vehicle communications systems, which are networks in which vehicles and roadside units are the communicating nodes, providing each other with information, such as safety warnings and traffic information. They can be effective in avoiding accidents and traffic congestion.

Among security concerns are authentication to ensure that all the communications are accurate and can't be spoofed, and privacy to ensure that the communications can't be used to track cars [NHTS14].

RFC 7744 provides additional examples of uses of constrained devices and their security requirements.

Design Trade-Offs

Figure 14.1 illustrates the trade-offs between security, cost, and performance in designing lightweight cryptographic algorithms. In general terms, for any given algorithm, the longer the key and the more rounds, the greater the security.

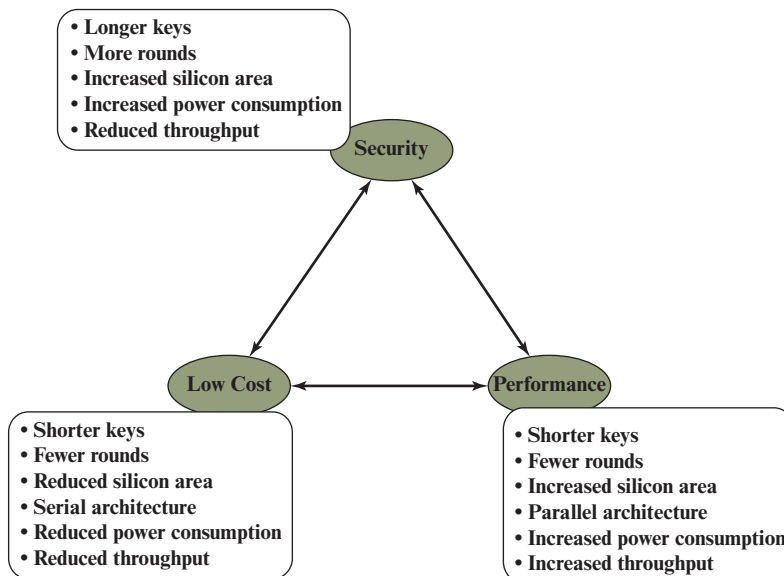

Figure 14.1 Lightweight Cryptography Trade-Offs

This implies a reduced throughput, in terms of the amount of plaintext processed per time unit, as well as increased power consumption. Similarly, the more complex an algorithm or its implementation, the more security it can provide, but this generally requires increased silicon area, either for hardware implementation or software implementation.

Thus, achieving greater security can degrade either cost or performance objectives, or both. As between performance and cost, there is also a trade-off in terms of the architecture, with a serial architecture generally providing lower cost, but a parallel architecture providing greater performance.

Security Requirements

ISO 29192 defines a minimum security strength for lightweight cryptography of 80 bits. The standard defines the security strength to be the number associated with the amount of work (i.e., the number of operations) that is required to break a cryptographic algorithm or system. A security strength of n implies that the required workload of breaking the cryptosystem is equivalent to 2^n executions of the cryptosystem. Most standards documents recommend a security strength of at least 128 bits. ISO 29192 indicates that there are some lightweight cryptographic applications that may allow lower security requirements, that is, they do not have to assume powerful adversaries. In cases where 80-bit keys are used, this implies that less data can be encrypted safely with a single key before rekeying is required. It is therefore important that designers of cryptographic security systems make sure that the safe operation limitations of lightweight cryptographic mechanisms are not exceeded for a single key.

In 2018, NIST announced a project to solicit designs for lightweight cryptographic algorithms [NIST18]. NIST is planning to develop and maintain a portfolio of lightweight algorithms and modes that are approved for limited use. Each algorithm in the portfolio will be tied to one or more profiles, which consist of algorithm goals and acceptable ranges for metrics. NISTIR 8114 (*Report on Lightweight Cryptography*, March 2017) indicates that the initial focus is the development of authenticated encryption with additional data (AEAD) and secure hash functions. NIST has issued a preliminary set of two profiles for these algorithms [NIST17], one for implementations in both hardware and software and one for hardware-only implementations (Figure 14.2). The details of these profiles are shown in Tables 14.2 and 14.3. Note that the minimum security requirement is 112 bits.

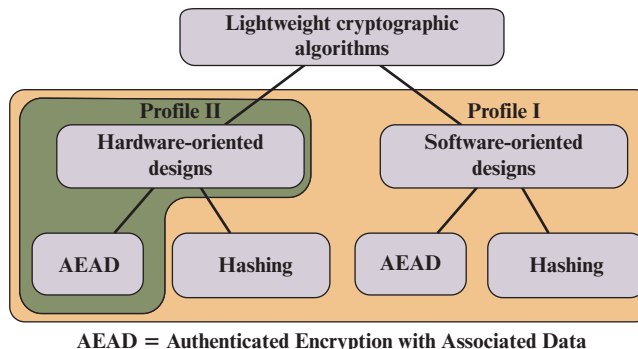

Figure 14.2 Profiles for Lightweight Cryptography

Table 14.2 Profile 1: AEAD and Hashing for Constrained Environments

Functionality	Authenticated Encryption with Associated Data and Hashing
Design goals	<ul style="list-style-type: none"> – Performs significantly better in constrained environments (hardware and embedded software platforms) compared to current NIST standards. – Both algorithms should be optimized to be efficient for short messages (e.g., as short as 8 bytes). – Message length shall be an integer number of bytes.
Physical characteristics	<ul style="list-style-type: none"> – Compact hardware implementations and embedded software implementations with low RAM and ROM usage should be possible.
Performance characteristics	<ul style="list-style-type: none"> – Performance on ASIC and FPGA should consider various standard cell libraries, the flexibility to support various implementation strategies (low energy, low power, low latency), with significant improvements over current NIST standards. – Performance on microcontrollers should consider a wide range of 8-bit, 16-bit, and 32-bit microcontroller architectures. – Preprocessing of a key (in terms of computation time and memory footprint) should be efficient.
Security characteristics	<p>AEAD</p> <ul style="list-style-type: none"> – A key length of 128 bits shall be supported. A longer key length may be supported, for example to provide security in the multi-key setting, or security against quantum computers. – Nonce lengths of up to 128 bits shall be supported. – Tag lengths of up to 128 bits shall be supported. – Plaintext lengths of up to $2^{50}-1$ bytes shall be supported. – Associated data of up to $2^{50}-1$ bytes shall be supported. – At least $2^{50}-1$ bytes can be processed securely under a single key. – Cryptanalytic attacks should require at least 2^{112} computations on a classical computer in a single-key setting. – Lends itself to countermeasures against various side-channel attacks, including timing attacks, simple and differential power analysis (SPA/DPA), and simple and differential electromagnetic analysis (SEMA/DEMA). <p>Hashing</p> <ul style="list-style-type: none"> – Cryptanalytic attacks should require at least 2^{112} computations on a classical computer. – Hash outputs of 256 bits must be supported, and longer hash values may be supported as well. – A maximum message length of $2^{50}-1$ bytes shall be supported. – Lends itself to countermeasures against various side-channel attacks, including timing attacks, simple and differential power analysis (SPA/DPA), and simple and differential electromagnetic analysis (SEMA/DEMA).

SIDE-CHANNEL ATTACK Both ISO 29192 and NIST highlight the need for resistance to side-channel attacks. A side-channel attack is an attack enabled by leakage of information from a physical cryptosystem [TIRI07]. An attacker exploits the physical environment to recover some leakage that can be used to break the cryptographic algorithm. Characteristics that could be exploited in a

Table 14.3 Profile 2: AEAD for Constrained Hardware Environments

Functionality	Authenticated Encryption with Associated Data
Design goals	<ul style="list-style-type: none"> – Performs significantly better compared to current NIST standards. – Performance for short messages (e.g., as short as 8 bytes) is important. – Message length shall be an integer number of bytes.
Physical characteristics	<ul style="list-style-type: none"> – Targeted toward constrained hardware platforms. – Compact hardware implementations should be possible.
Performance characteristics	<ul style="list-style-type: none"> – Performance on ASIC and FPGA should consider a wide range of standard cell libraries and vendors. – Flexibility to support various implementation strategies (low energy, low power, low latency). – Preprocessing of a key (in terms of computation time and memory footprint) should be efficient.
Security characteristics	<ul style="list-style-type: none"> – A key length of 128 bits shall be supported. A longer key length may be supported, for example, to provide security in the multi-key setting, or security against quantum computers. – Nonce lengths of up to 128 bits shall be supported. – Tag lengths of up to 128 bits shall be supported. – Plaintext lengths of up to $2^{50} - 1$ bytes shall be supported. – Associated data of up to $2^{50} - 1$ bytes shall be supported. – At least $2^{50} - 1$ bytes can be processed securely under a single key. – Cryptanalytic attacks should require at least 2^{112} computations on a classical computer in a single-key setting. – Lends itself to countermeasures against various side-channel attacks, including timing attacks, simple and differential power analysis (SPA/DPA), and simple and differential electromagnetic analysis (SEMA/DEMA).

side-channel attack include running time, power consumption, and electromagnetic and acoustic emissions.

Figure 14.3 illustrates the basic operation of a side-channel attack. The attacker has access to the side-channel information emanating from the device, and may have either plaintext or ciphertext or both available. If operation is observable over an extended period of time, quite effective attacks are possible. The analysis consists in guessing key bits based on differences in the side-channel information. For example, the processing required for a 1 bit may be more than required for a 0 bit, and this affects processing time and power consumption. An attack on AES typically estimated the leakage caused by a single key byte. The result is that the entire 128-bit key can be found with 16×2^8 tests [TIRI07].

Constrained devices are often particularly vulnerable to side-channel attacks because they are located in environments that are not physically secure.

Countermeasures to side-channel attacks seek to eliminate, or at least diminish, the correlation between bits of the key and side-channel information. Examples of countermeasures include adding random delay to computations, inserting instruction cycles that have no effect in such a way that every cryptographic computation takes the same amount of time, and adding hardware logic that results in random amounts of power consumption.

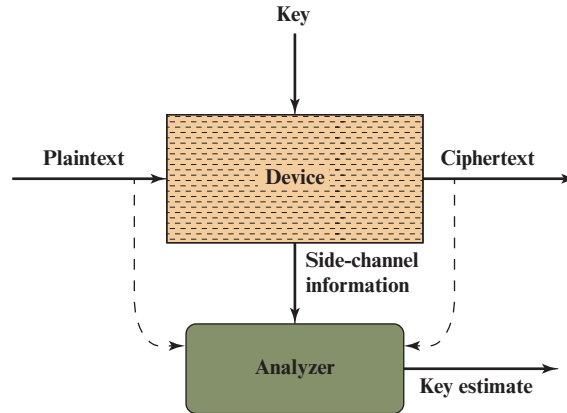

Figure 14.3 Side-Channel Attack

14.2 LIGHTWEIGHT CRYPTOGRAPHIC ALGORITHMS

To meet the requirements of lightweight cryptography, a number of new algorithms have been proposed [BIRY17, CRYP17]. Typical characteristics include:

- Many iterations of simple rounds
- Simple operations like XORs, rotation, 4×4 S-boxes, and bit permutations
- Smaller block sizes (e.g., 64 or 80 bits)
- Smaller key sizes (e.g., 96 or 112 bits)
- Simpler key schedules
- Small security margins by design
- Many iterations of simple rounds
- Simplified key schedules that can generate sub-keys on the fly

These design choices yield smaller security margins compared to established algorithms such as AES and SHA-2.

Authenticated Encryption with Additional Data

ARCHITECTURE STRATEGIES For both block and stream ciphers, the implementation to meet design goals makes use of one of three major hardware architecture options: parallel (loop unrolled), round-wise (rolled), and serial. Figure 14.4, based on one in [CRYP17], illustrates these options in general terms. A parallel implementation uses additional logic so that several round operations are performed in parallel. Typically, some form of pipelining is used so that during a given clock cycle, multiple rounds are being executed. In a round-wise, or rolled implementation, each round is executed separately, with execution of one round completed before the next round is begun. In both rolled and unrolled implementations, the architecture stores the full internal state, plus the key state if any, and then performs one round using a circuit operating on the full state at once. To achieve minimum chip area, a serial implementation can be used. With serial

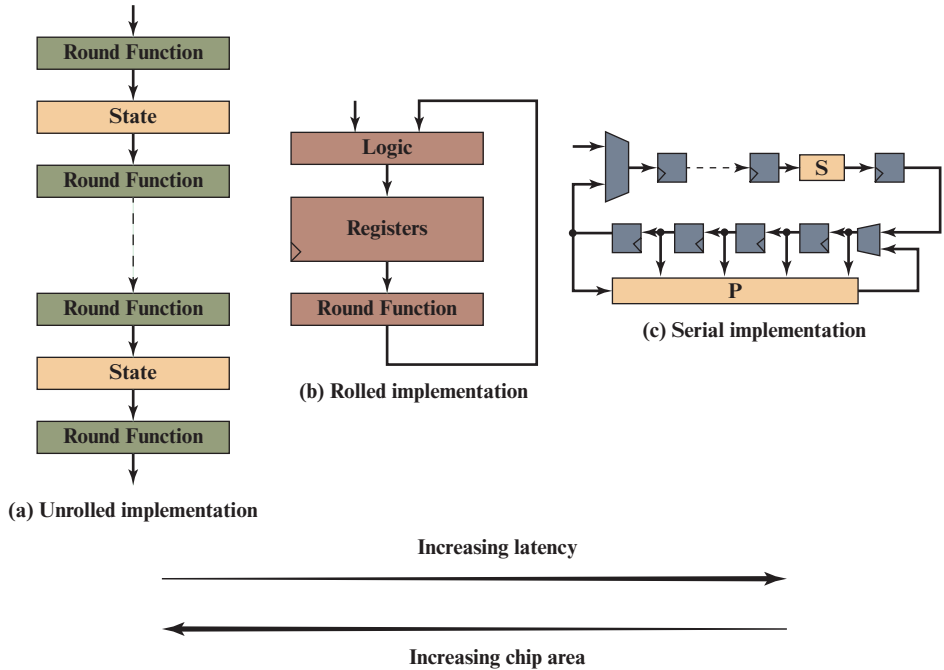

Figure 14.4 Basic Implementation Methods for Symmetric Ciphers

implementation, a block is processed in fractions, so that multiple operations are needed to complete a single round. With serial implementation, only a fraction of the state is updated at a time. As Figure 14.4 illustrates, moving from unrolled to rolled to serial implementation reduces the chip area required at the cost of increased execution time.

BLOCK CIPHERS Block ciphers are employed as the basic functional unit in a mode of operation to achieve encryption and in some authentication modes. Thus, they are intended for use processing multiple blocks of data. ISO 29192-1 indicates that the security of most modes of operation for block ciphers (including MAC and hash constructions) degrades at $q^2/2^n$, where n is the block size in bits and q is the number of blocks encrypted. For example, when $n = 64$, encryption of 2^{32} blocks is sufficient to expose the block cipher to attack. Therefore, care has to be taken since a shorter block size implies that less data can be encrypted using a single key.

An example of a lightweight cryptographic block cipher is the Scalable Encryption Algorithm (SEA) [STAN06]. SEA uses the Feistel cipher structure (Figure 4.3). SEA can have an arbitrary block size n (as long as $n = 6b$ for some b), word size, and number of rounds. It is based on the following operations:

- Bitwise exclusive-OR: \oplus
- Application of an S-box: S
- Rotation of the words in a vector of words: R = rotate left: R^{-1} = rotate right
- Bit rotation inside a word: r
- Addition modulo 2^b : \boxplus

The basic parameters are:

n : block size and key size

b : word size

$n_b = \frac{n}{2^b}$: number of words per Feistel branch

n_r : number of rounds

The only constraint is that the block size must be a multiple of six times the word size (n is a multiple of $6b$). Thus, for an 8-bit processor, the block size can be 48, 96, 144, and so on.

Figure 14.5 illustrates the functionality of a single round. For each round, a block is divided into left and right halves and the round operations are:

Encryption	$L_{i+1} = R_i$ $R_{i+1} = R(L_i) \oplus r(S(R_i \boxplus K_i))$
Decryption	$L_{i+1} = R_i$ $R_{i+1} = R^{-1}(L_i \oplus r(S(R_i \boxplus K_i)))$
Subkey generation	$KL_{i+1} = KR_i$ $KR_{i+1} = KL_i \oplus R(r(S(KR_i \boxplus C_i)))$

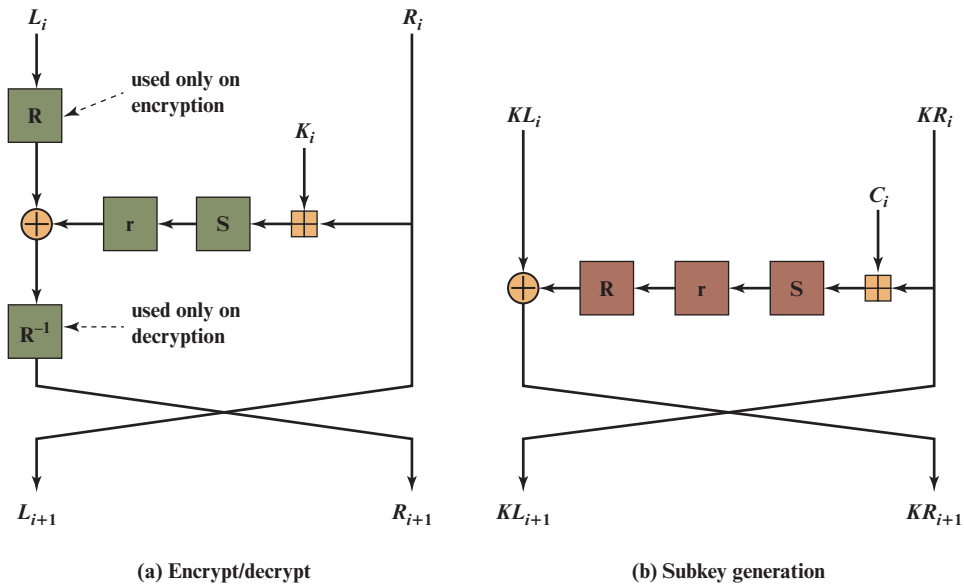

\oplus = bitwise XOR \boxplus = addition mod 2^b

R = word rotation to the left R^{-1} = word rotation to the right
 r = bit rotation S = S-box substitution

Figure 14.5 One Round of Scalable Encryption Algorithm

The substitution box is defined by a 3-bit substitution table. For a 3-bit chunk x :

x	000	001	010	011	100	101	110	111
$S(x)$	000	101	110	111	100	011	001	010

Data can be processed in blocks of 3 words (24 bits) at a time, providing opportunity for parallel implementation of the S-box substitution to the eight 3-bit chunks.

The constant C_i is a n_b -word vector in which all of the words have the value 0 except the least significant word, which has the value i .

SEA has a number of strengths for use in a constrained device. Only a few operations need to be implemented. It is easily scalable in terms of both block and key size. SEA is designed to provide good nonlinearity and diffusion. The authors look at various types of attacks to justify the design decisions in the creation of SEA [STAN06]. A number of studies have shown that SEA provides a good balance of compact implementation and performance [KUMA11a, KUMA10 CAKI10, MACE08].

STREAM CIPHERS Stream ciphers are also a promising approach to symmetric encryption for constrained environments. Chapter 8 presents one example of a stream cipher that is suitable for constrained devices: Grain-128.

Hash Functions

Traditional hash functions may not meet the requirements for implementation on constrained devices. NISTIR 8114 points out two ways in which lightweight hash functions differ from more traditional ones:

- **Smaller internal state and output sizes:** Large output sizes are important for applications that require collision resistance of hash functions. For applications that do not require collision resistance, smaller internal states and output sizes might be used. When a collision-resistant hash function is required, it may be acceptable that this hash function has the same security against preimage, second-preimage, and collision attacks. This may reduce the size of the internal state.
- **Smaller message size:** Conventional hash functions are expected to support inputs with very large sizes (around 2^{64} bits). In most of the target protocols for lightweight hash functions, typical input sizes are much smaller (e.g., at most 256 bits). Hash functions that are optimized for short messages may therefore be more suitable for lightweight applications.

An example of a lightweight cryptographic hash functions is PHOTON [GUO11]. PHOTON is one of the hash functions specified in ISO 29192. It is also listed in [CRYP17].

PHOTON uses a sponge structure, similar to that used by SHA-3, as shown in Figure 14.6. Sponge functions have been well studied in terms of security and can be designed for compact implementation. The sponge function has three main elements:

- An internal state of t bits consisting of a c -bit capacity and an r -bit rate ($t = c + r$). The rate r is the number of bits processed at each iteration, and the capacity c is a measure of the complexity of the construction and therefore its security. The hash size n is equal to c .

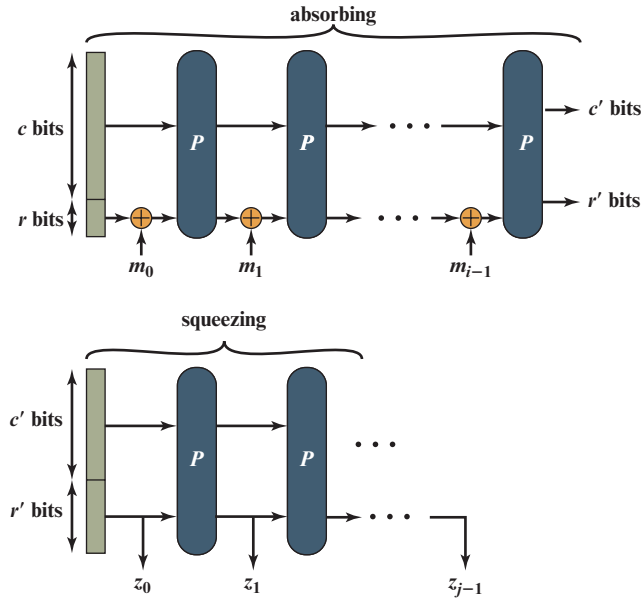

Figure 14.6 Photon Sponge Structure

- A permutation function P that operates on the internal state at each iteration.
- A padding function that appends sufficient bits to the data input.

The sponge structure consists of an absorbing phase that absorbs the message blocks into an internal state, followed by a squeezing phase that generates the hash blocks. For the absorbing phase, the data input, or message, is padded by appending a 1 bit and as many zeros as needed so that the input length is an integral multiple of r . The input is divided into i r -bit message blocks m_0, \dots, m_{i-1} . The internal state is initialized to the value $S_0 = IV = \{0\}^{t-24} || n/4 || r || r'$, where the three values are each coded in 8 bits and n is the hash size. For each of the i iterations, m_i is XORed with the rate portion of the internal state and then the permutation P is applied to the t -bit state.

For the squeezing phase, the internal state is divided into r' and c' sections, which may differ in lengths from r and c . Increasing r' reduces the time spent in the squeezing phase but might reduce preimage security. This phase produces a sequence of ir' -bit hash blocks z_0, \dots, z_{j-1} , with $j = \lceil n/r' \rceil - 1$. The hash output is $z_0 || \dots || z_{j-1}$. If the hash output is not a multiple of r' , it is truncated to n bits.

Using the structure of Figure 14.6, five variants of PHOTON are defined, as shown in Table 14.4. The five versions provide increasing levels of security at the cost of increasing size and processing time. Note the small size of the internal state, of between 100 and 288 bits. By contrast, SHA-3 has an internal state of 1600 bits, and SHA-512 has an internal state of 512 bits.

The internal structure of the permutation function consists of unkeyed AES-like primitives especially derived for hardware optimization. The advantage of AES-like primitives is that PHOTON takes advantage of the previous cryptanalysis

Table 14.4 PHOTON Versions

PHOTON- $n/r/r'$	n (Hash Size)	r (Message Block Size)	r' (Hash Block Size)	t (Internal State)
PHOTON-80/20/16	80	20	16	100
PHOTON-128/16/16	128	16	16	144
PHOTON-160/36/36	160	36	36	196
PHOTON-224/32/32	224	32	32	256
PHOTON-256/32/32	256	32	32	288

Note: All values are expressed in bits.

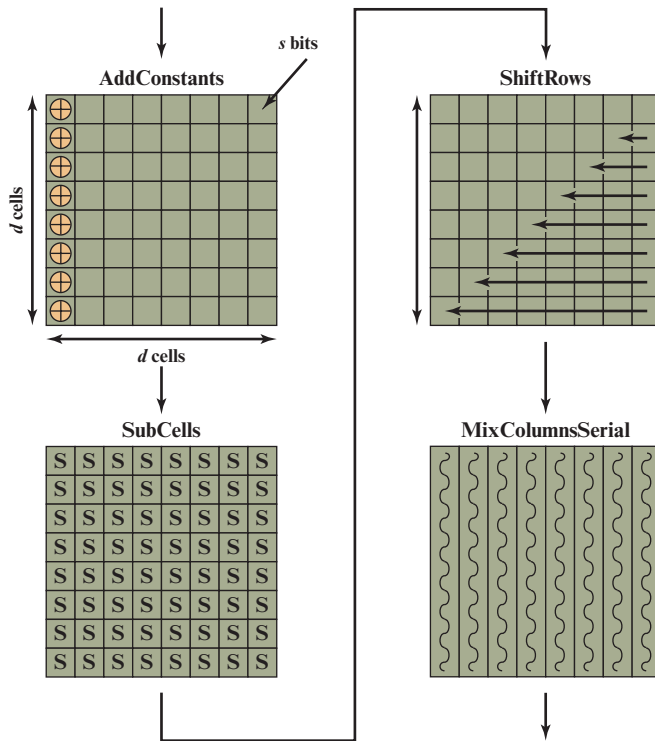

Figure 14.7 One Round of a PHOTON Permutation

performed on AES and on AES-based hash functions. Figure 14.7 illustrates the permutation P structure. The t -bit internal state is organized of a matrix of $(d \times d)$ s -bit cells. Thus, $i = (d \times d) + s$. The permutation consists of 12 rounds of four stages:

- **AddConstants:** Round constants are XORed to the first column of the matrix.
- **SubCells:** An S-box is used to map each matrix entry to a new value.
- **ShiftRows:** The position of the cells in each row is rotated, as illustrated.
- **MixColumnsSerial:** This function linearly mixes all the columns independently.

The authors claim that PHOTON is extremely lightweight, very close to the theoretical optimum and achieves excellent area/throughput trade-offs.

Message Authentication Codes

[CRYP17] points out that there are two approaches to developing a lightweight message authentication code (MAC). The first approach is to use an existing MAC with an underlying lightweight cryptographic algorithm. The most prominent examples are CMAC and HMAC, both discussed in Chapter 12. Because the overheads of CMAC and HMAC are not high, a lightweight MAC can be implemented by configuring these algorithms with an underlying lightweight cryptographic algorithm. In the case of CMAC, this means using a lightweight symmetric encryption algorithm. In the case of HMAC, this means using a lightweight hash algorithm.

The second approach is to specifically design a new lightweight MAC algorithm. There has been much more work done on lightweight encryption algorithms and cryptographic hash codes than on lightweight MAC algorithms.

One example of a newly designed MAC is SipHash [AUMA12]. It is the only MAC listed in [CRYP17] and it has been widely implemented. The principal objectives for the design of SipHash were:

- Optimize the MAC algorithm for short messages. This is in keeping with the typical exchanges be constrained devices.
- Build a MAC that is secure, efficient, and simple.

Two important characteristics of SipHash are that it does not require key expansion and that minimal internal state is required. SipHash has a sponge type of structure consisting of a compression phase, during which the message is absorbed and compressed, followed by a finalization phase, which provide further mixing of the bits. SipHash is a family of functions denoted SipHash- c - d , where c is the number of compression rounds between message blocks and d is the number of finalization rounds. The rounds, denoted SipRound, are identical for the two phases. The variables used in all of the SipHash variants are as follows:

- A 128-bit key k , divided into two 64-bit blocks k_0 and k_1 .
- A b -byte message m , that is divided into $w = \lceil (b + 1)/8 \rceil$ 64-bit blocks m_0, \dots, m_{w-1} , where m_{w-1} includes the last $(b \bmod 8)$ bytes of m followed by null bytes ending with a byte encoding the positive integer $b \bmod 256$.
- An internal state consisting of four 64-bit words, labeled v_0, v_1, v_1, v_2 .
- A 64-bit tag. This is the output of the SipHash function, used for message authentication.

Figure 14.8a illustrates the compression state. To begin, the internal state is initialized as:

$$\begin{aligned} v_0 &= k_0 \oplus C_0 = k_0 \oplus 736f6d6570736575 \\ v_1 &= k_1 \oplus C_1 = k_1 \oplus 646f72616e646f6d \\ v_2 &= k_0 \oplus C_2 = k_0 \oplus 6c7967656e657261 \\ v_3 &= k_1 \oplus C_3 = k_1 \oplus 7465646279746573 \end{aligned}$$

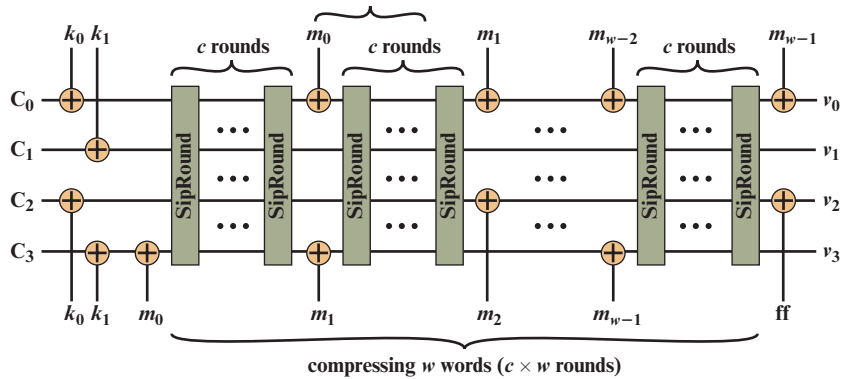

(a) Compression phase

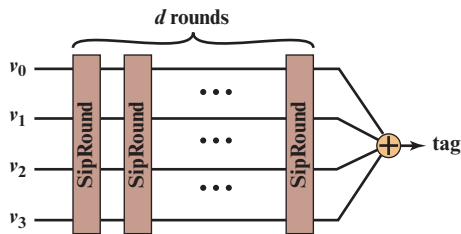

(b) Finalization phase

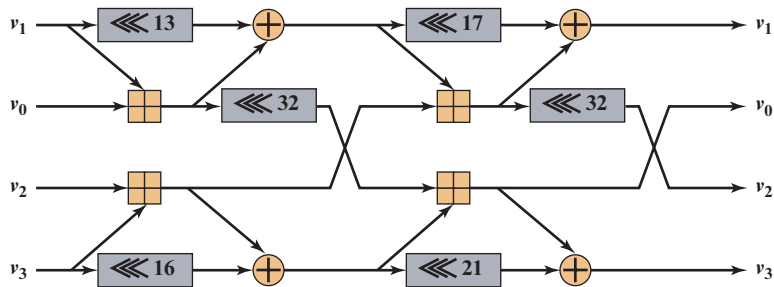

(c) SipHash round

Figure 14.8 SipHash Message Authentication Code

Thus, each half of each key is subject to two different bit flipping operations. Then each message word is processed as follows:

1. The internal state is modified by $v_3 = v_3 \oplus m_0$.
2. This is followed by c iterations of SipRound.
3. This is followed by $(w - 1)$ steps consisting of

$$v_0 = v_0 \oplus m_{i-1}$$

$$v_3 = v_3 \oplus m_i$$

c iterations of SipRound

4. This is followed by

$$v_0 = v_0 \oplus m_{w-1}$$

$$v_3 = v_3 \oplus \text{ff}$$

In the finalization phase (Figure 14.8b), there are d more rounds applied to the internal state. Then, the 64-bit tag is generated as $v_0 \oplus v_1 \oplus v_2 \oplus v_3$.

The function SipRound transforms the internal state using the simple functions of addition, exclusive-OR, and bitwise left logical rotate, as shown in Figure 14.8c.

The authors believe that SipHash-2-4 provides strong security and is the recommended “fast” option. SipHash-4-8 is a conservative choice, providing higher security at about half the speed.

Asymmetric Cryptographic Algorithms

Neither NISTIR 8114 nor [CRYP17] mention developing lightweight asymmetric cryptographic algorithms. So far, there has been little interest in this area. Asymmetric algorithms typically operate on only small blocks of data and are relatively infrequently invoked. Thus, there is less motivation for attempting lightweight versions. Additionally, most asymmetric algorithms are already relatively compact.

One potential application is to use a lightweight hash function in a digital signature algorithm.

14.3 POST-QUANTUM CRYPTOGRAPHY CONCEPTS

Post-quantum cryptography is concerned with the development of cryptographic algorithms that are secure against the potential development of quantum computers. Whereas lightweight cryptography is primarily concerned with the efficiency and compactness of symmetric encryption algorithms and cryptographic hash functions, post-quantum cryptography is concerned with the security of asymmetric cryptographic algorithms.

We begin with a brief introduction to quantum computing and then look at the implications for asymmetric cryptography.

Quantum Computing

Quantum computing is based on the representation of information in a form analogous to the behavior of elementary particles in quantum physics. A practical application of this representation, in terms of performing calculations, requires producing a physical system that performs computation making use of quantum physical principles. As yet, no such general-purpose computing system has been developed but in principle it is possible to do so.

Information in a quantum computer is represented as quantum bits, or qubits. A qubit can be viewed as a quantum analog of a classical bit, one that obeys the laws of quantum physics. In particular, qubits have two properties that are relevant to quantum computing:

- **Superposition:** A qubit does not exist in a single state but in a superposition of different states. It is only when a measurement is taken that the qubit collapses into a unique state (binary 1 or 0). Prior to that it is only possible to express a

probability that the qubit is a 1 or a 0. The qubit can be thought of a vector of unit magnitude in a two-dimensional vector space.

- **Entanglement:** Qubits can be linked to each other over the course of operations reflecting the physical phenomenon known as quantum entanglement. The relevant implication of this is that state of a multiple-qubit system is not represented by a linear combination of the state vectors of each qubit but rather a tensor product.

It is well beyond the scope of this brief introduction to explain the implications of these two properties in terms of computation. In essence, because of entanglement, a set of multiple qubits has a state space that grows exponentially with the number of qubits. Because of the superposition of states, one operator applied to the set operates on all the states in parallel. This enables allowing quantum computers to look through millions of potential solutions at once, rather than sequentially. Thus, computational power scales exponentially.

The challenges of building a practical quantum computer are immense. The various physical realizations of qubits that are being investigated are very fragile, with some requiring extremely cold temperatures. As reported in [GREE18], quantum computing systems will need new algorithms, software, interconnects, and a number of other yet-to-be-invented technologies specifically designed to take advantage of system's tremendous processing power—as well as allow the computer's results to be shared or stored.

Shor's Factoring Algorithm

Public-key cryptography supports three critical cryptographic functionalities: public-key encryption, or asymmetric encryption, digital signatures, and key exchange. The underlying algorithms that are primarily implemented for these functions are Diffie-Hellman key exchange, the RSA cryptosystem, and elliptic curve cryptosystem. In turn, the security of these algorithms depends on the difficulty of solving certain number theoretic problems, mainly integer factorization or discrete logarithms.

Shor [SHOR97] has described algorithms designed for a quantum computer (operate on qubits) for prime factorization and discrete logarithms that execute in polynomial time. For example, the number of steps in the factorization algorithm grows polynomial to the number of digits of the integer to be factored. The implication of Shor's work is profound for public-key systems. For example, a white paper from the European Telecommunications Standards Institute [ETSI14] indicates that to attack a 3072-bit RSA key, a quantum computer must have a few thousand logical qubits. If and when quantum computers that can handle that number of qubits is practical, such a key is no longer safe. Further, using Shor's algorithm, the number of qubits needed scales linearly with the bit length of the RSA or ECC key. Moving to a larger RSA key provides security only until a larger quantum computer is built. And, as [ETSI14] points out, doubling the size of an RSA or ECC key doubles the burden on a quantum computer, but increases the running time for using the keys on a conventional computer by a factor of 8. This type of response to quantum computing is clearly unsustainable.

Figure 14.9 illustrates the impact for RSA. The individual diamonds indicate the year when a given RSA key length was demonstrated to be broken. The progress is due to a combination of increased computing power and more sophisticated cryptanalytic algorithms. Based on the trend line, a key size of 1024 bits is secure for the near future and a key size of 2048 bits is secure for a very long time. However, if practical

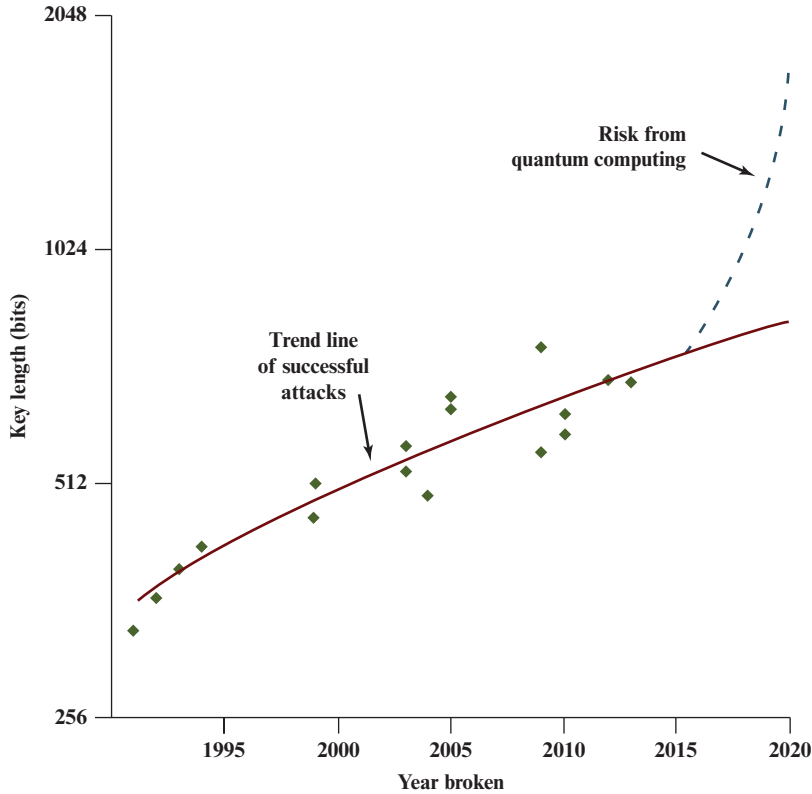

Figure 14.9 RSA Key Lengths Broken by Conventional Computing Architectures

quantum computers are introduced, and Shor's algorithm is used, the trend line could become exponential, the key length of 2018 could be broken relatively soon.

Grover's Algorithm

Grover's algorithm [GROV96] searches an unordered list in $O(\sqrt{n})$ time, while conventional algorithms require $O(n)$. This is not as dramatic as the speedup achieved by Shor's algorithms, but it is a significant improvement for the type of brute-force approach typically used for symmetric encryption and hash algorithms. Grover's algorithm can reduce the cost of attacking a symmetric cryptographic algorithm. For a cryptographic algorithm with a key size of n bits, Grover's algorithm can theoretically reduce the security of that algorithm to one with a key size of $n/2$ bits. This is not nearly as serious as the threat to asymmetric algorithms posed by Shor's algorithm. For example, a 128-bit AES key is considered secure for the foreseeable future. To guard against a quantum attack using Grover's algorithm, the same level of security could be maintained by moving to a 256-bit key. Similarly, Grover's algorithm can theoretically reduce the security of a cryptographic hash algorithm by a factor of two. This can be countered by doubling the hash length.

Furthermore, it has been shown that an exponential speed up for search algorithms is impossible, suggesting that existing symmetric algorithms and hash functions should be secure in a quantum era [BENN97].

Cryptoperiods

Although practical large-scale quantum computers are not likely for a number of years, there has been considerable interest and some urgency in developing cryptographic algorithms that are secure against such computers. The following are examples:

- In 2015, the U.S. National Security Agency (NSA) released a major policy statement on the need for post-quantum cryptography. Prior to this, NSA had defined a suite of algorithms (Suite B) that were approved for protection of both sensitive but unclassified (SBU) and classified information, including the approval of ECC. The 2015 NSA statement indicated that partners and vendors that had not yet implemented Suite B should not expend additional resources on developing ECC products because NSA planned to transition to post-quantum algorithms in the foreseeable future.
- In 2016, NIST announced a request for submissions for public-key **post-quantum cryptographic algorithms**. Round 2 submissions have been received and, as of this writing, are being evaluated.
- In 2014, the ETSI Quantum Safe Cryptography (QSC) Industry Specification Group was formed to assess and make recommendations for quantum-safe cryptographic primitives and protocols.

To understand the motivation for rapid progress in this area, we need to discuss the concept of **cryptoperiod**. The cryptoperiod of a cryptographic key is the time span during which a specific cryptographic key is authorized for use for its defined purpose. This is an important consideration. A number of potential security threats make it advisable that any key not be used for a prolonged period of time. These threats include:

- **Brute-force attacks:** As raw processing power and the ability to use numerous processors in parallel increase, a given key length becomes increasingly vulnerable and longer key lengths are advised. Any of the shorter keys in use need to be retired as quickly as possible and longer key lengths employed. For example, NIST used to recommend the use of 1024-bit keys for certain asymmetric algorithms but now recommends 2048 bits for these algorithms.
- **Cryptanalysis:** Over time, flaws may be discovered in a cryptographic algorithm that make it feasible to “break” the algorithm. An example of this is the original NIST standard hash algorithm, SHA-1, which was used in their Digital Signature Algorithm. Once these weaknesses were discovered, NIST migrated to SHA-2 and SHA-3. Similarly, methods have been found for breaking algorithms such as the RSA asymmetric algorithm at rates faster than brute force, which can be thwarted by using longer keys.
- **Other security threats:** Beyond simply attacking an algorithm directly in an attempt to discover a key that is being used, there are a variety of other methods of attack. This includes attacks on the mechanisms and protocols associated with the keys, key modification, and achieving unauthorized disclosure. The longer a particular key is used for encryption and decryption, the greater the chance that some means of learning the key will succeed.

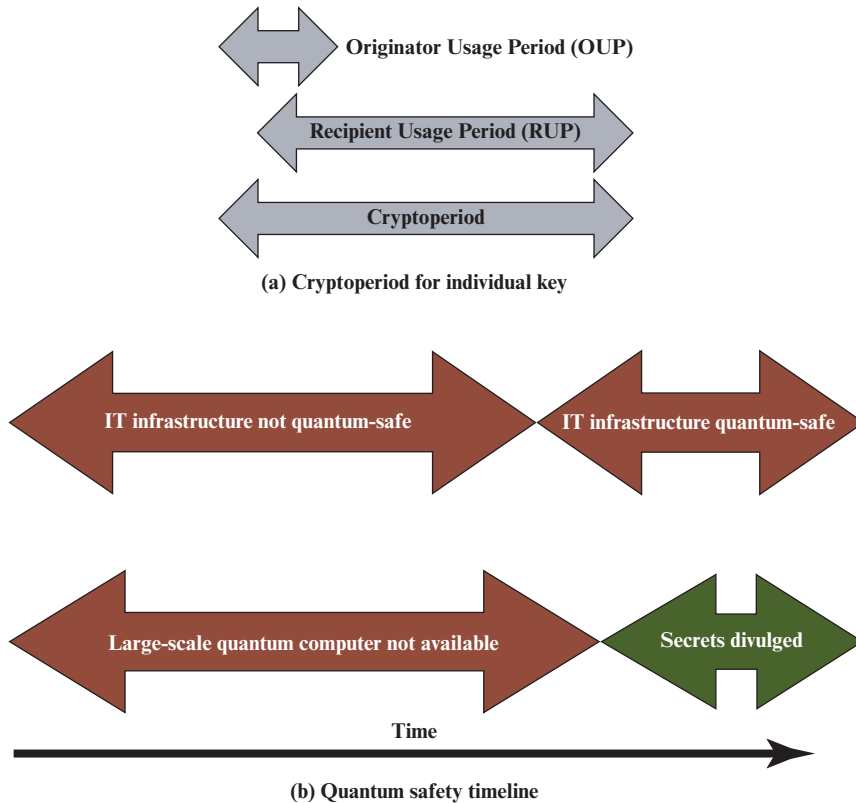

Figure 14.10 Lead Time for Quantum Safety

Accordingly, an enterprise should have policies for the maximum cryptoperiod of each key type.

Figure 14.10a illustrates the two aspects of a cryptoperiod. The originator usage period (OUP) refers to the time during which data may be encrypted, and the recipient usage period (RUP) is the time during which such data may continue to be maintained in its encrypted form and subject to decryption. The RUP often starts at the beginning of the OUP, but there may be some delay before data can be decrypted. More significantly, the end of the RUP may extend for a considerable length of time beyond the end of the OUP. That is, the policy may state that a given key may no longer be used for encrypting new data, but the data that have already been encrypted may be retained in the encrypted form, available for decryption for a further period of time. Hence the cryptoperiod extends from the start of the OUP to the end of the SUP. Table 14.5 shows the cryptoperiods suggested in SP 80-57.

Quantum Safety

Equivalent to the term post-quantum cryptography is the term *quantum-safe cryptography*. The latter term emphasizes the need for creating cryptographic algorithms that are safe, or secure, against quantum computing algorithms. Figure 14.10b illustrates what this means in terms of times. At present, no organization

Table 14.5 Suggested Cryptoperiods from SP 800-57

Key Type	OUP	RUP
1. Private Signature Key	1 to 3 years	–
2. Public Signature-Verification Key	Several years (depends on key size)	
3. Symmetric Authentication Key	≤ 2 years	≤ OUP + 3 years
4. Private Authentication Key	1 to 2 years	
5. Public Authentication Key	1 to 2 years	
6. Symmetric Data Encryption Keys	≤ 2 years	≤ OUP + 3 years
7. Symmetric Key Wrapping Key	≤ 2 years	≤ OUP + 3 years
8. Symmetric RBG Keys	See [SP800-90]	–
9. Symmetric Master Key	About 1 year	–
10. Private Key Transport Key	≤ 2 years	
11. Public Key Transport Key	1 to 2 years	
12. Symmetric Key Agreement Key	1 to 2 years	
13. Private Static Key Agreement Key	1 to 2 years	
14. Public Static Key Agreement Key	1 to 2 years	
15. Private Ephemeral Key Agreement Key	One key-agreement transaction	
16. Public Ephemeral Key Agreement Key	One key-agreement transaction	
17. Symmetric Authentication Key	≤ 2 years	
18. Private Authentication Key	≤ 2 years	
19. Public Authentication Key	≤ 2 years	

or IT installation is using post-quantum cryptographic algorithms and so cannot be considered quantum safe. This situation is satisfactory until such time as large scale-quantum computers are available. If such computers become available prior to the widespread introduction of post-quantum algorithms, then there will be a period of time in which all IT installations are vulnerable to attack. Thus, there is some urgency in developing and deploying post-quantum algorithms.

The issue of timing also relates to the concept of the cryptoperiod. Any IT installation managing a large number of symmetric and asymmetric keys with different end dates for the respective cryptoperiods. The aggregate of all those keys and their cryptoperiods indicate how long it is after post-quantum cryptography is introduced before all pre-quantum keys are phased out.

As pointed out in [ETSI14], and illustrated in Figure 14.11, three levels of security-related entities are vulnerable to quantum attack:

- **Cryptosystems:** A cryptosystem consists of a set of cryptographic algorithms together with the key management processes that support use of the algorithms in some application context. Any cryptosystem that relies on the security of integer factoring or discrete logarithms is vulnerable. This includes RSA, DSA, DH, ECDH, ECDSA, and other variants of these ciphers.

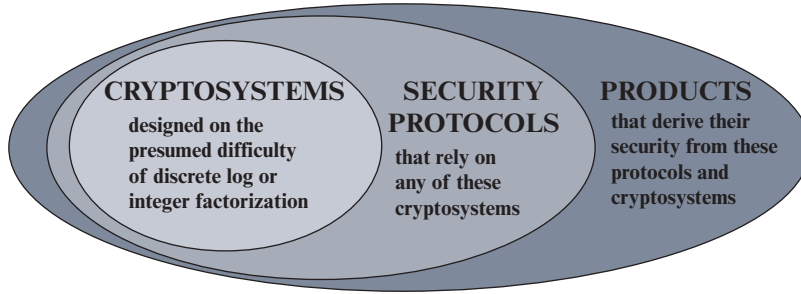

Figure 14.11 Entities Vulnerable to Quantum Computing

Table 14.6 Impact of Quantum Computing on Common Cryptographic Algorithms

Cryptographic Algorithm	Type	Purpose	Impact from Large-Scale Quantum Computer
AES	Symmetric key	Encryption	Larger key sizes needed
SHA-2, SHA-3	Cryptographic hash	Hash function	Larger output needed
RSA	Asymmetric key	Signature, key establishment	No longer secure
ECDSA, ECDH (elliptic curve cryptography)	Asymmetric key	Signature, key exchange	No longer secure
DSA (finite field cryptography)	Asymmetric key	Signature, key exchange	No longer secure

Almost all public key cryptography in fielded security products and protocols today use these types of ciphers.

- **Security protocols or security components of network protocols:** Any such protocols that derive security from the public-key algorithms listed in the preceding bullet are vulnerable.
- **Products:** Any products or security systems that derive security from the above protocols are vulnerable.

Cryptosystems or portions of cryptosystems that employ symmetric ciphers or hash functions can be made quantum safe by increasing the size of the key or the hash length, respectively. It is public-key systems that are of concern. Table 14.6 summarizes these considerations.

14.4 POST-QUANTUM CRYPTOGRAPHIC ALGORITHMS

The types of asymmetric algorithms that are vulnerable to quantum computing are in the following categories:

- **Digital signatures:** Public-key signature algorithms for generating and verifying digital signatures.

Table 14.7 Submissions to NIST Post-Quantum Cryptography Competition

	Signatures	KEM/Encryption	Total
Lattice-based	4	24	28
Code-based	5	19	24
Multivariate	7	6	13
Hash-based	4	—	4
Other	3	10	13
Total	23	59	82

- **Encryption:** Used for encrypting symmetric keys for transport from one party to another. Also used in various key establishment algorithms. In general terms, these proceed as follows: Each party has either one or two key pairs, and the public keys are made known to the other party. The key pairs are used to compute a shared secret value, which is then used with other information to derive keying material using a key derivation function.
- **Key-Establishment Mechanisms (KEMs):** Refers to schemes such as Diffie-Hellman key exchange.

There is no single widely accepted alternative to the existing algorithms based on integer factorization or discrete logarithms. Of the approaches reported in the literature, four general types of algorithms predominate:

- **Lattice-based cryptography:** These schemes involve the construction of primitives that involve lattices.
- **Code-based cryptography:** These schemes are based on error-correcting codes.
- **Multivariate polynomial cryptography:** These schemes are based on the difficulty of solving systems of multivariate polynomials over finite fields.
- **Hash-based signatures:** These are digital signatures constructed using hash functions.

An indication of the interest shown in these approaches is found in the submissions to the NIST effort at post-quantum standardization. As reported in NISTIR 8105 (*Report on Post-Quantum Cryptography*, April 2016), NIST hopes to standardize a number of algorithms that can be used to replace or complement existing asymmetric schemes. For the first round, NIST has received 82 submissions, broken down as shown in Table 14.7.

There are several reasons why NIST does not intend to settle on a single standard:

- The requirements for public-key encryption and digital signatures are more complicated than those of symmetric encryption and cryptographic hash functions.
- The current scientific understanding of the power of quantum computers is far from comprehensive.

- Some of the candidate post-quantum cryptosystems may have completely different design attributes and mathematical foundations, so that a direct comparison of candidates would be difficult or impossible.
- The various approaches exhibit different advantages and disadvantages, beyond considerations of security.

Although there will be significant differences within each of the four approaches listed above, the following general statements can be made:

- **Lattice-based cryptography:** These schemes are relatively simple, efficient, and highly parallelizable.
- **Code-based cryptography:** These schemes are quite fast but require very large key sizes.
- **Multivariate polynomial cryptography:** For digital signatures, these schemes require very large key sizes.
- **Hash-based signatures:** Many of the more efficient hash-based signature schemes have the drawback that the signer must keep a record of the exact number of previously signed messages, and any error in this record will result in insecurity. Another drawback is that they can produce only a limited number of signatures. The number of signatures can be increased, even to the point of being effectively unlimited, but this also increases the signature size.

Because of the complexity of the mathematics and the implementation of these types of schemes, a full description is beyond our scope. The remainder of this section provides a brief overview of each of the four approaches.

Lattice-Based Cryptographic Algorithms

An m -dimensional lattice of rank n is the set of vectors that can be expressed as the sum of integer multiples of a specific set of n vectors, collectively called the basis of the lattice. More formally, a lattice can be defined as:

$$L = \left\{ \sum_{i=1}^n x_i \mathbf{b}_i \mid x_i \in \mathbb{Z}, \mathbf{b}_i \in \mathbb{R}^m \right\}$$

where the \mathbf{b}_i s are linearly independent vectors of length m over the real numbers and the x_i are integers. The set of vectors \mathbf{b}_i is called a lattice basis. The lattice basis can be represented by a matrix \mathbf{B} , where the i th column of the matrix is \mathbf{b}_i . We refer to m as the dimension of the lattice, and n the rank of the lattice. A lattice can be depicted as n points defined by the basis in m -dimensional space; that is, each point is the end point of one of the basis vectors. A lattice is said to be full-rank when $n = m$. There are infinitely many lattices of the same dimension.

A basis vector \mathbf{b}_i consists of m real numbers $(b_{i,1}, \dots, b_{i,m})$. The length of the vector is the real number:

$$\|\mathbf{b}_i\| = \sqrt{b_{i,1}^2 + b_{i,2}^2 + \dots + b_{i,m}^2}$$

The basis for a given lattice is not unique. The existence of multiple bases for the same lattice is important for the development of cryptographic algorithms, because

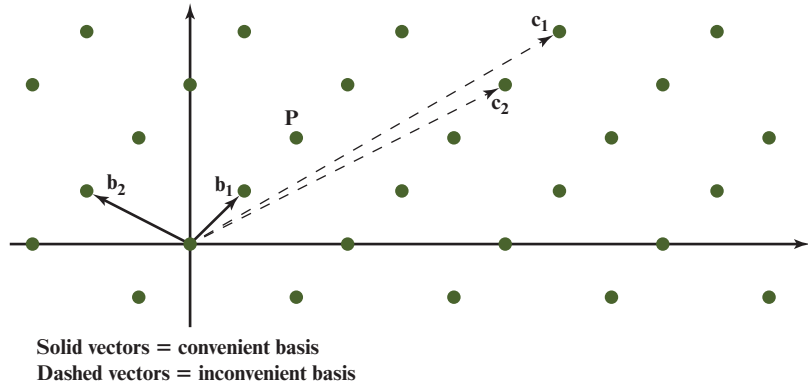

Figure 14.12 Two Bases for a Two-Dimensional Lattice

some bases are easier to handle than others. Figure 14.12, which depicts a lattice with $n = m = 2$, illustrates the concepts just introduced. The basis $\mathbf{b}_1 = (0.5, 0.5)$, $\mathbf{b}_2 = (-1, 0.5)$, with lengths $\|\mathbf{b}_1\| = 0.707$ and $\|\mathbf{b}_2\| = 1.12$, defines all of the points shown in the figure. For example, the point $\mathbf{P} = (1, 1)$ is equal to $x_1\mathbf{b}_1 + x_2\mathbf{b}_2 = x_1(0.5, 0.5) + x_2(-1, 0.5)$, for $x_1 = 2, x_2 = 0$. The same lattice is also defined by the basis $\mathbf{c}_1 = (3.5, 2)$, $\mathbf{c}_2 = (3, 1.5)$, with lengths $\|\mathbf{c}_1\| = 4.03$ and $\|\mathbf{c}_2\| = 3.35$. For example, $\mathbf{P} = (1, 1)$ is equal to $x_1\mathbf{c}_1 + x_2\mathbf{c}_2$ for $x_1 = 2/3, x_2 = -2/3$. With either basis, any point in the space can be defined by a linear combination of its two vectors, but the basis $\mathbf{b}_1, \mathbf{b}_2$ is computationally more convenient.

The essence of a lattice-based cryptographic algorithms is to exploit a hard problem in lattices. One such problem is the Closest Vector Problem (CVP) which can be stated as follows: given a basis of a lattice L and a vector $v \in \mathbb{R}^m$, find a lattice vector that minimizes the distance to v . Note that, in general, v defines a point that is not part of the lattice. The Shortest Vector Problem (SVP) is to find the shortest non-zero vector within a lattice. There is no known quantum algorithm for solving CVP or SVP for lattices of large dimension. In practice, the cryptographic algorithms that have been proposed assume that a relaxed variant of CVP or SVP is still hard to solve.

The most widely studied lattice-based approach is the NTRU family of cryptographic algorithms. Such algorithms use a specific class of lattices that have an extra symmetry. In all NTRU-based schemes, the private key represents a lattice basis consisting of short vectors, while the public key represents a lattice basis consisting of longer vectors. In general terms, these algorithms work as follow. A message is encoded as a vector \mathbf{m} . A random point in the lattice defined by the private key basis is added to \mathbf{m} to form a vector \mathbf{e} . The public key has been defined by multiplying the private key basis \mathbf{B} by a matrix \mathbf{U} , yielding another basis \mathbf{B}' for the same lattice, with longer vectors. To decrypt the message, find the lattice point closest to the ciphertext vector $\mathbf{C} = \mathbf{e}\mathbf{U}^{-1}$, and subtract it from the ciphertext vector. The result is the original plaintext vector. That is, \mathbf{B}' is the public key and it is possible to find the lattice point \mathbf{X} closest to \mathbf{C} , such that $\mathbf{C} - \mathbf{X} = \mathbf{m}$. However, given \mathbf{B}' , it is computationally infeasible to determine \mathbf{B} .

The matrix \mathbf{U} in the above scheme must be a unimodular matrix, which means that the determinant of \mathbf{U} is 1 or -1 . For example, the matrix

$$\begin{pmatrix} 1 & 2 \\ 0 & 1 \end{pmatrix}$$

is unimodular with a determinant of 1. It can be shown that the inverse \mathbf{U}^{-1} of unimodular matrix \mathbf{U} is also unimodular, and that two bases \mathbf{B}_1 , \mathbf{B}_2 define the same lattice if and only if $\mathbf{B}_2 = \mathbf{B}_1\mathbf{U}$.

A number of variations on this basic scheme are currently being pursued [LAUT17].

Code-Based Cryptographic Algorithms

An error correction code (ECC) allows data that is being read or transmitted to be checked for errors and, when necessary, corrected. Figure 14.13 illustrates in general terms how the process is carried out. On the source end, each k -bit block of data is mapped into an n -bit block ($n > k$) called a codeword, using an ECC encoder.

The ECC is referred to as an (n, k) ECC. Encoding can be described as multiplying a k -bit data vector \mathbf{m} by a $k \times n$ matrix \mathbf{G} to yield an n -bit codeword vector \mathbf{c} :

$$\mathbf{c} = \mathbf{m}\mathbf{G}$$

For each generator matrix, there is an $(n - k) \times k$ parity check matrix \mathbf{H} whose rows are orthogonal to those of \mathbf{G} ; that is, $\mathbf{G}\mathbf{H}^T = \mathbf{0}$.

The codeword, whether stored or transmitted, is subject to impairments, which may produce one or more bit errors in the block. At the destination, the received codeword may contain errors. This block is passed through an ECC decoder, with one of four possible outcomes:

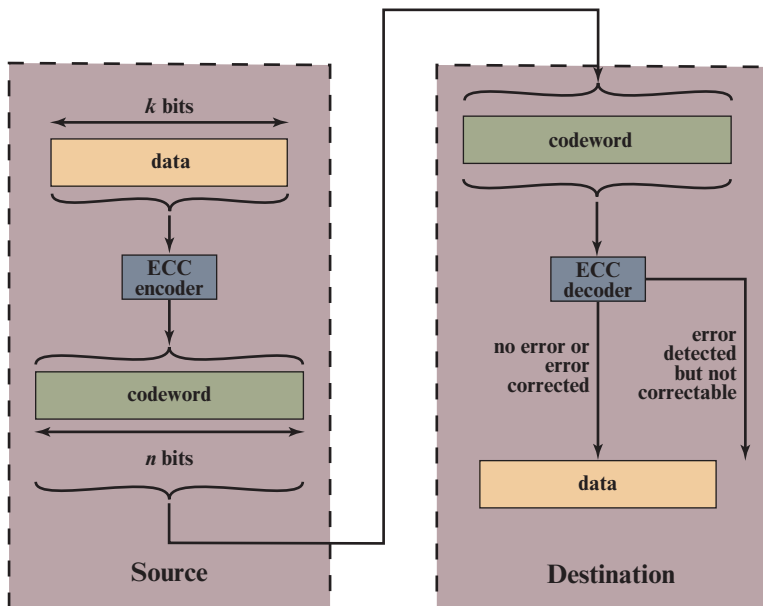

Figure 14.13 (n, k) Error Correction Code

- **No errors:** If there are no bit errors, the input to the ECC decoder is identical to the original codeword, and the decoder produces the original data block as output.
- **Detectable, correctable errors:** For certain error patterns, it is possible for the decoder to detect and correct those errors. Thus, even though the incoming data block differs from the transmitted codeword, the decoder is able to map this block into the original data block.
- **Detectable, not correctable errors:** For certain error patterns, the decoder can detect but not correct the errors. In this case, the decoder simply reports an uncorrectable error.
- **Undetectable errors:** For certain, typically rare, error patterns, the decoder does not detect that the error and maps the incoming n -bit data block into a k -bit block that differs from the original k -bit block.

How is it possible for the decoder to correct bit errors? In essence, error correction works by adding sufficient redundancy to the data block. The redundancy makes it possible for the receiver to deduce what the original block was, even in the face of a certain level of error rate.

Error detection and correction can be expressed as follows. The received codeword \mathbf{c}' is multiplied by the transpose of \mathbf{H} , that is $\mathbf{c}'\mathbf{H}^T$. If the result is a zero vector, then no error is detected. If the result is nonzero, then the resulting vector, known as the syndrome, can be used to correct errors. The exact process for correction depends on the nature of the ECC.

An example of efficient error correcting codes are Goppa codes, which can be turned into a secure coding scheme by keeping the encoding and decoding functions a secret, and only publicly revealing a disguised encoding function that allows the mapping of a plaintext message to a scrambled set of code words. Only someone in possession of the secret decoding function can recover the plaintext. This technique is computationally hard to reverse using either a conventional or quantum computer.

An (n, k) Goppa code can correct any number of bit errors $t = (n - k)/\log_2(n)$ bits. The first scheme based on this code is by McEliece [MCEL78]. The private key consists of three matrices. A specific Goppa code is chosen, and represented by an $k \times n$ matrix \mathbf{G} . Also chosen are an $n \times n$ permutation matrix \mathbf{P} and an arbitrary $k \times k$ invertible binary matrix \mathbf{S} . The public key is the matrix $\mathbf{G}' = \mathbf{SGP}$, plus the value t ; the private key consists of the three matrices that are multiplied together.

Suppose \mathbf{G}' is the public key of entity A, and entity B wishes to encrypt a k -bit message \mathbf{x} with \mathbf{G}' . B sends $\mathbf{x}' = \mathbf{xG}' + \mathbf{e}$, where \mathbf{e} is a random n -bit error vector with exactly t ones. After the A receives \mathbf{x}' , to decrypt the message, A computes $\mathbf{x}'\mathbf{P}^{-1} = (\mathbf{xG}' + \mathbf{e})\mathbf{P}^{-1} = \mathbf{xSG} + \mathbf{eP}^{-1}$. By using the decoding algorithm of the code, A can remove the error term and is left with \mathbf{xS} . Because \mathbf{S} is invertible, A can recover \mathbf{x} .

A number of refinements of this scheme have been developed to reduce key size [SEND18].

Multivariate-Based Cryptographic Algorithms

Multivariate schemes are based on the difficulty of solving systems of multivariate quadratic polynomials over finite fields. The term multivariate polynomial refers to a polynomial in more than one variable, and the term quadratic polynomial refers

to a polynomial of degree 2. In general, these schemes can be described as follows. The public key consists of a set of m polynomials:

$$P(x_1, \dots, x_n) = (p_1(x_1, \dots, x_n), p_2(x_1, \dots, x_n), \dots, p_m(x_1, \dots, x_n))$$

which can be expanded to the following:

$$\begin{aligned} p_1(x_1, \dots, x_n) &= \sum_{i=1}^n \sum_{j=1}^n p_{1,ij} x_i x_j + \sum_{i=1}^n p_{1,i} x_i + p_{1,0} \\ p_2(x_1, \dots, x_n) &= \sum_{i=1}^n \sum_{j=1}^n p_{2,ij} x_i x_j + \sum_{i=1}^n p_{2,i} x_i + p_{2,0} \\ p_m(x_1, \dots, x_n) &= \sum_{i=1}^n \sum_{j=1}^n p_{m,ij} x_i x_j + \sum_{i=1}^n p_{m,i} x_i + p_{m,0} \end{aligned}$$

with m equal to the number of equations and n equal to the number of variables.

In general terms, encryption using the public key is performed as follows: Given a plaintext $m = (y_1, \dots, y_n)$, the ciphertext is:

$$P(m) = (p_1(y_1, \dots, y_n), p_2(y_1, \dots, y_n), \dots, p_m(y_1, \dots, y_n)) = (c_1, \dots, c_m)$$

The private key is the inverse mapping P^{-1} and provides the plaintext:

$$(y_1, \dots, y_n) = P^{-1}(c_1, \dots, c_m)$$

The assumption is that given P it is difficult to find P^{-1} , but not vice versa. More specifically, the security of the scheme depends of the difficulty of the following problem. For a given $P(x_1, \dots, x_n)$, find a vector (z_1, \dots, z_n) such that $P(z_1, \dots, z_n) = \mathbf{0}$.

The digital signature is formed in a similar way. A hash of message m is computed that can be expressed as $H(m) = (h_1, \dots, h_n)$. Given a signature (s_1, \dots, s_n) for m , the signature can be verified by testing if $H(m)$ is equal to $P(s_1, \dots, s_n)$.

We give two simple examples for multivariate polynomials over the finite field $\text{GF}(2^2)$. The only irreducible polynomial of degree 2 for this field is $x^2 + x + 1$. Table 14.8 shows addition and multiplication mod $(x^2 + x + 1)$. The polynomials in the field are symbolically represented by the integers. Suppose the public key consists of:

$$\begin{aligned} p_1(x_1, x_2, x_3) &= 1 + x_3 + 2x_1x_2 + x_3^2 \\ p_2(x_1, x_2, x_3) &= 2 + x_1 + 2x_2x_3 + x_2 \\ p_3(x_1, x_2, x_3) &= 1 + x_2 + x_1x_3 + x_1^2 \end{aligned}$$

Given a 6-bit message 01000001 represented as $(x_1, x_2, x_3) = (2, 0, 1)$, encryption of the message with the public key is performed as follows:

$$\begin{aligned} p_1(2, 0, 1) &= 1 + 1 + (2 \times 2 \times 0) + (1 \times 1) = 1 \\ p_2(2, 0, 1) &= 2 + 2 + (2 \times 0 \times 1) + 0 = 0 \\ p_3(2, 0, 1) &= 1 + 1 + (2 \times 1) + (2 \times 2) = 1 \end{aligned}$$

The ciphertext is $(1, 0, 1)$.

Table 14.8 Arithmetic in $GF(2^2)$

Polynomial	0	1	X	$x + 1$
Binary representation	00	01	10	11
Integer representation	0	1	2	3

(a) Polynomial Representation

+	0	1	2	3
0	0	1	2	3
1	1	0	3	2
2	2	3	0	1
3	3	2	1	0

(b) Addition

×	0	1	2	3
0	0	0	0	0
1	0	1	2	3
2	0	2	3	1
3	0	3	1	2

(c) Multiplication

Now consider the public key:

$$p_1(x_1, x_2, x_3) = 1 + x_2 + 2x_0x_2 + 3x_1^2 + 3x_1x_2 + x_2^2$$

$$p_2(x_1, x_2, x_3) = 1 + 3x_0 + 2x_1 + x_2 + x_0^2 + x_0x_1 + 3x_0x_2 + x_1^2$$

$$p_3(x_1, x_2, x_3) = 3x_2 + x_0^2 + 3x_1^2 + x_1x_2 + 3x_2^2$$

Suppose a message m with hash value $H(m) = (1, 2, 3)$. The owner of the private key matching the above public key generates the signature $(0, 0, 1)$. The signature can be verified by a recipient by generating $H(m)$ and encrypting the result with the public key. In this case, the calculation yields:

$$p_1(1, 2, 3) = 1 + 3 + (2 \times 1 \times 3) + (3 \times 2 \times 2) + (3 \times 2 \times 3) + (3 \times 3) = 0$$

$$p_2(1, 2, 3) = 1 + (3 \times 1) + (2 \times 2) + 3 + (1 \times 1) + (1 \times 2) + (3 \times 1 \times 3) + (2 \times 2) = 0$$

$$p_3(1, 2, 3) = (3 \times 3) + (1 \times 1) + (3 \times 2 \times 2) + (2 \times 3) + (3 \times 3 \times 3) = 1$$

which verifies the public key.

The public-private key construction can be described in a way that is similar to that of code-based schemes. The process starts with an easily invertible quadratic map $F: K^n \rightarrow K^m$. For the public key, the structure of this mapping is hidden by combining F with two invertible maps $S: K^m \rightarrow K^m$ and $T: K^n \rightarrow K^n$. The public key P is the composed map $S \circ F \circ T: K^n \rightarrow K^m$. The private key consists of the three maps.

A number of variations on this basic scheme are currently being pursued [DING17].

Hash-Based Digital Signature Algorithms

To get an idea of how a hash-based signature algorithm works, we first consider a scheme proposed by Lamport [LAMP79]. Assume a hash function that produces a b -bit hash value. Thus, for SHA-256, $b = 256$. In Lamport's scheme, a public/private key pair is used only once for a given message m . The steps involved are as follows:

1. Compute the b -bit hash value $H(m)$.
2. Generate $2b$ secrets bit strings, two for each bit location k in $H(m)$, $S_{0,k}$ and $S_{1,k}$. The set of secret values constitutes the private key.

3. The public key consists of the hash values of each secret value: $H(S_{0,k})$, $H(S_{1,k})$, $k = 1, \dots, b$.
4. The digital signature consists of half of the hash values calculated in step 3. For the block m , the signature is generated as follows. If the k th bit of $H(m)$ is 0, then the k th element of the signature is $S_{0,k}$; if the k th bit of $H(m)$ is 1, then the k th element of the signature is $S_{1,k}$. Thus, the signature reveals half of the private key.
5. Signature verification involves the following: The verifier calculates $H(m)$. Then the bits of $H(m)$ are used to pick out the corresponding elements of the public key. So, if the k th bit is 1, select $H(S_{1,k})$. Then the b hashes in the signature are compared to the b hashes selected from the public key. If all match, the signature is verified.

There are a number of drawbacks to this scheme. The signing of a message reveals half of the private key. This is not enough to allow an attacker to sign additional messages with different digests, but it would not be secure to use this key pair more than once. Further, both the public and private keys are of considerable length.

Merkle [MERK79] proposed a technique that builds on the Lamport scheme, using the concept of a hash tree. It allows a signer to precompute a number of public-private key pairs that can be used to generate signatures that can all be verified with the same public key. And the long-term public key need only be the size of a hash value. For this scheme, a tree of hash values is constructed. The scheme allows the signing of a number of messages $N = 2^n$, where n is an integer. The signer generates N private keys X_i with $0 \leq i \leq 2^n - 1$, and computes the corresponding public keys Y_i . Each public key is the concatenation of the $2b$ hash values described in step 3 of the Lamport scheme. Then a hash tree is formed. Each node of the tree is labeled $h_{i,j}$, where i denotes the level of the node and corresponds to the distance of the node from a leaf. Thus, a leaf of the tree is level 0 and the root of the tree is level n . Figure 14.14a shows a tree for $n = 3$.

The tree is constructed in pairs, starting with the leaves. Each leaf consists of the hash of one of the public keys. For higher levels, each pair of values at one level is concatenated to form a double block, and the hash of that block is computed. This process continues until a single value results, known as the Merkle root. The Merkle root becomes the single public key, to be used to verify up to N signatures. This has two advantages: the public key is quite small, and it can be used for multiple signatures.

The process for signing a message m_i is as follows. First the Lamport digital signature LS_j is generated from $H(m_i)$, as before, consisting of the set of b secret strings $S_{j,k}$ for $j = 0$ or 1 , $k = 1, \dots, b$. The value LS_j forms part of overall digital signature for the message, which is available for verification. However, in this scheme, the verifier does not have possession of the Lamport public key Y_i , so this must be supplied as part of the signature. Further, the verifier must be able to authenticate that this public key Y_i is valid. To do this, the verifier needs to trace a path from the leaf to the root and confirm the root value. For this calculation, the verifier needs every node on

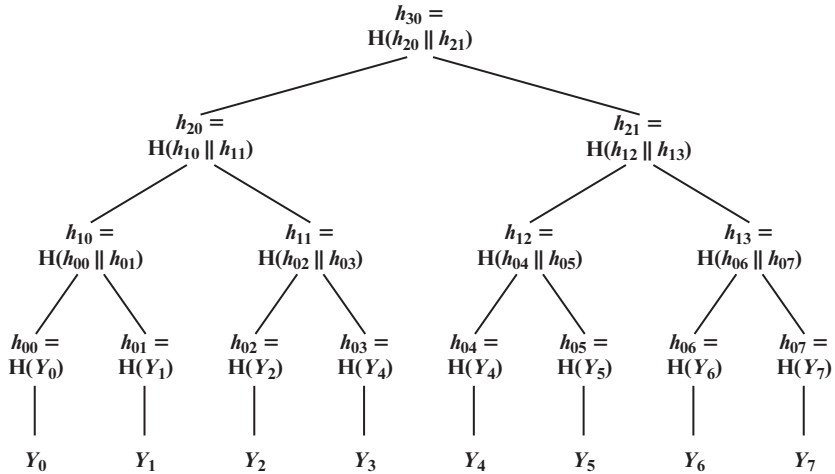

(a) Merkle tree with eight leaves

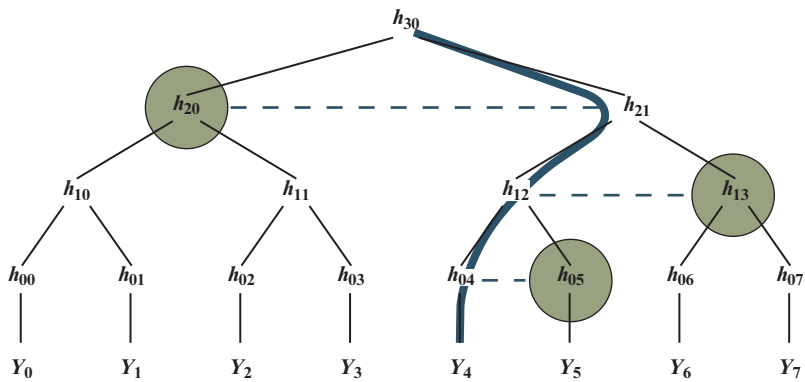

(b) Merkle tree with authentication path

Figure 14.14 Example of Merkle Hash Tree

the path, plus the value of the brother node at each level; these are also provided in the signature. Putting this all together, the signature S_i for m_i consists of the following:

$$S_i = (LS_i, Y_i, h_{0,x}, h_{1,x}, \dots, h_{n-1,x})$$

where x equals either $l + 1$ or $l - 1$ at each level l of the tree.

An example should make this process clear. Figure 14.14b shows the Merkle tree with eight leaves and the path to the root from Y_4 . To authenticate the public key, the verifier computes

$$H(H(H(H(Y_4) || h_{05}) || h_{13}) || h_{20})$$

If this value equals the public key h_{30} , then Y_4 is authenticated. Once Y_4 is authenticated, it can be used to verify the signature Y_4 .

An important drawback of Merkle-related schemes is that the signer must keep track of which onetime signature keys have already been used. This can be difficult in large-scale environments. Stateless variants are a matter of current research [BUTI17].

14.5 KEY TERMS AND REVIEW QUESTIONS

Key Terms

constrained device cryptoperiod cryptosystem deeply embedded system embedded system	lightweight cryptographic algorithm lightweight cryptography microcontroller	post-quantum cryptographic algorithm post-quantum cryptography quantum computing quantum safety
---	--	---

Review Questions

- 14.1 Define embedded system.
- 14.2 Define constrained device.
- 14.3 List and briefly explain three classes of constrained devices.
- 14.4 What are the chief design constraints for lightweight cryptographic algorithms?
- 14.5 What are the typical characteristics of lightweight cryptographic algorithms?
- 14.6 What are the main types of cryptographic algorithms for which lightweight cryptography is relevant?
- 14.7 Briefly explain the rationale for post-quantum cryptography.
- 14.8 What are the main types of cryptographic algorithms for which post-quantum cryptography is relevant?
- 14.9 List the four main mathematical approaches being studied for post-quantum cryptography.

CRYPTOGRAPHIC KEY MANAGEMENT AND DISTRIBUTION

15.1 Symmetric Key Distribution Using Symmetric Encryption

- Key Distribution Options
- Third-Party Key Distribution Options
- Key Hierarchy

15.2 Symmetric Key Distribution Using Asymmetric Encryption

- Simple Secret Key Distribution
- Secret Key Distribution with Confidentiality and Authentication

15.3 Distribution of Public Keys

- Public Announcement of Public Keys
- Publicly Available Directory
- Public-Key Authority
- Public-Key Certificates

15.4 X.509 Certificates

- Certificates
- X.509 Version 3

15.5 Public-Key Infrastructure

15.6 Key Terms, Review Questions, and Problems

LEARNING OBJECTIVES

After studying this chapter, you should be able to:

- ◆ Discuss the concept of a key hierarchy.
- ◆ Understand the issues involved in using asymmetric encryption to distribute symmetric keys.
- ◆ Present an overview of approaches to public-key distribution and analyze the risks involved in various approaches.
- ◆ List and explain the elements in an X.509 certificate.
- ◆ Present an overview of public-key infrastructure concepts.

The secure use of cryptographic key algorithms depends on the protection of the cryptographic keys. All keys need to be protected against modification, and secret and private keys need to be protected against disclosure. **Cryptographic key management** is the process of administering or managing cryptographic keys for a cryptographic system. It involves the generation, creation, protection, storage, exchange, replacement, and use of keys and enables selective restriction for certain keys. In addition to access restriction, key management also involves the monitoring and recording of each key's access, use, and context. A key management system will also include key servers, user procedures, and protocols, including cryptographic protocol design. The security of the cryptosystem is dependent upon successful key management.

The topics of cryptographic key management and cryptographic key distribution are complex, involving cryptographic, protocol, and management considerations. The purpose of this chapter is to give the reader a feel for the issues involved and a broad survey of the various aspects of key management and distribution. For more information, the place to start is the three-volume NIST SP 800-57, followed by the recommended readings listed at the end of this chapter.

15.1 SYMMETRIC KEY DISTRIBUTION USING SYMMETRIC ENCRYPTION

This section looks at techniques for distributing secret keys using only symmetric encryption techniques.

Key Distribution Options

For symmetric encryption to work, the two parties to an exchange must share the same key, and that key must be protected from access by others. Furthermore, frequent key changes are usually desirable to limit the amount of data compromised if an attacker learns the key. Therefore, the strength of any cryptographic system rests

with the *key distribution technique*, a term that refers to the means of delivering a key to two parties who wish to exchange data, without allowing others to see the key. For two parties A and B, **key distribution** can be achieved in a number of ways, as follows:

1. A can select a key and physically deliver it to B.
2. A third party can select the key and physically deliver it to A and B.
3. If A and B have previously and recently used a key, one party can transmit the new key to the other, encrypted using the old key.
4. If A and B each has an encrypted connection to a third party C, C can deliver a key on the encrypted links to A and B.

Options 1 and 2 call for manual delivery of a key. For link encryption, this is a reasonable requirement, because each link encryption device is going to be exchanging data only with its partner on the other end of the link. However, for **end-to-end encryption** over a network, manual delivery is awkward. In a distributed system, any given user or server may need to engage in exchanges with many other users and servers over time. Thus, each endpoint needs a number of keys supplied dynamically. The problem is especially difficult in a wide area distributed system.

The scale of the problem depends on the number of communicating pairs that must be supported. If end-to-end encryption is done at a network or IP level, then a key is needed for each pair of hosts on the network that wish to communicate. Thus, if there are n hosts, the number of required keys is

$$\frac{n(n-1)}{2}$$

If encryption is done at the application level, then a key is needed for every pair of users or processes that require communication. Thus, a network may have hundreds of hosts but thousands of users and processes. A network using node-level encryption with 1000 nodes would conceivably need to distribute as many as half a million keys. If that same network supported 10,000 applications, then as many as 50 million keys may be required for application-level encryption.

Returning to our list, option 3 is a possibility for either link encryption or end-to-end encryption, but if an attacker ever succeeds in gaining access to one key, then all subsequent keys will be revealed. Furthermore, the initial distribution of potentially millions of keys must still be made.

For end-to-end encryption, some variation on option 4 has been widely adopted. In this scheme, a key distribution center is responsible for distributing keys to pairs of users (hosts, processes, applications) as needed. Each user must share a unique key with the key distribution center for purposes of key distribution.

Third-Party Key Distribution Options

Figure 15.1 illustrates two different options, each with two variations, for key distribution. The numbers along the lines represent the steps of the exchange. In these examples, there exists a connection between entities A and B, who wish to exchange information using cryptographic techniques. For this purpose, they require a

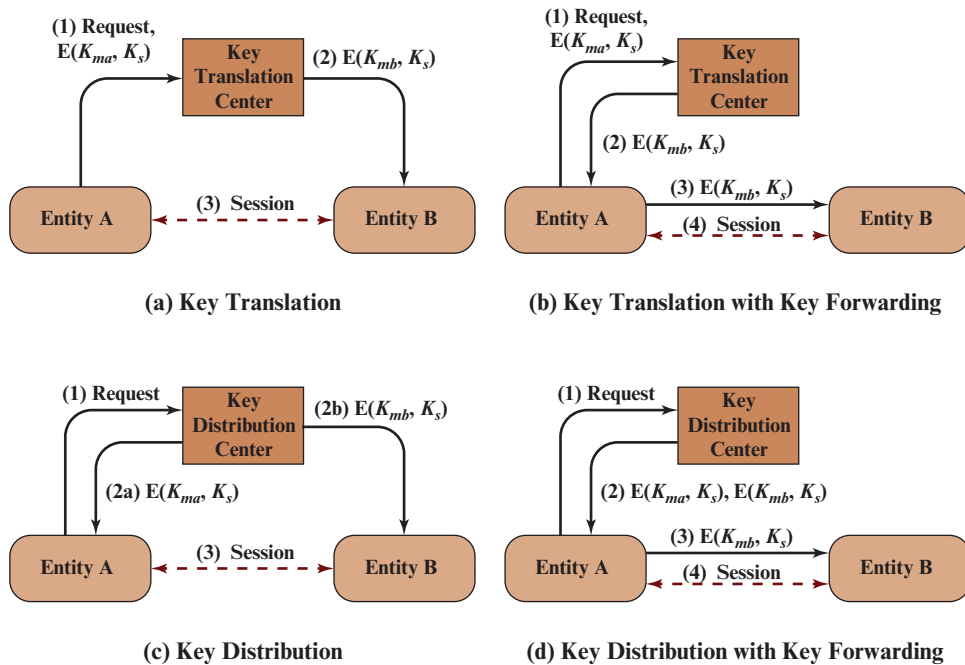

Figure 15.1 Key Distribution Between Two Communicating Entities

temporary **session key** that will last for the duration of a logical connection, such as a TCP connection. A and B each share a long-lasting **master key** with a third party that is involved in providing the session key. For this discussion, the session key is labeled K_s and the master key between entities A and B and the third party are labeled K_{ma} and K_{mb} , respectively.

A **key translation center (KTC)** transfers symmetric keys for future communication between two entities, at least one of whom has the ability to generate or acquire symmetric keys by themselves. Entity A generates or acquires a symmetric key to be used as a session key for communication with B. A encrypts the key using the master key it shares with the KTC and sends the encrypted key to the KTC. The KTC decrypts the session key, reencrypts the session key in the master key it shares with B, and either sends that reencrypted session key to A (Figure 15.1a) for A to forward to B or sends it directly to B (Figure 15.1b).

A **key distribution center (KDC)** generates and distributes session keys. Entity A sends a request to the KDC for a symmetric key to be used as a session key for communication with B. The KDC generates a symmetric session key, and then encrypts the session key with the master key it shares with A and sends it to A. The KDC also encrypts the session key with the master key it shares with B and sends it to B (Figure 15.1c). Alternatively, it sends both encrypted key values to A, and A forwards the session key encrypted with the master key shared by the KDC and B to B (Figure 15.1d).

The foregoing discussion leaves out a number of details. For example, parties that exchange keys need to authenticate themselves to each other.

Timestamps are often used to limit the time in which a key exchange can take place and/or the lifetime of an exchanged key. Chapter 16 examines several detailed approaches to third-party symmetric key exchange in the context of Kerberos.

Key Hierarchy

A common requirement in a variety of protocols, such as IEEE 802.11i and IPsec, discussed in Part Six, is for the encryption of a symmetric key so that it can be distributed to two parties for future communication. Quite often, a protocol calls for a hierarchy of keys, with keys lower on the hierarchy used more frequently, and changed more frequently to thwart attacks (Figure 15.2). A higher-level key, which is used infrequently and therefore more resistant to cryptanalysis, is used to encrypt a newly created lower-level key so that it can be exchanged between parties that share the higher-level key. The term **ephemeral key** in Figure 15.2 refers to a key that is used only once or at most is very short-lived.

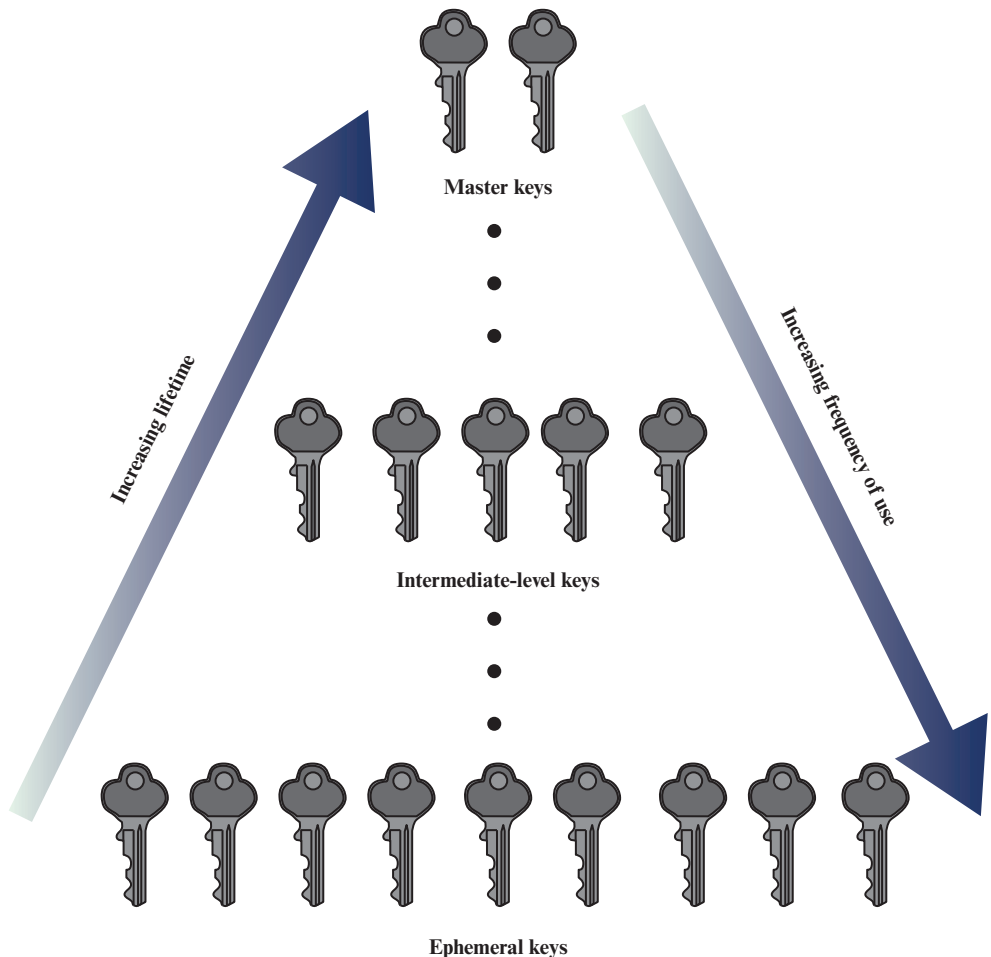

Figure 15.2 Symmetric Key Hierarchy

15.2 SYMMETRIC KEY DISTRIBUTION USING ASYMMETRIC ENCRYPTION

Because of the inefficiency of public-key cryptosystems, they are almost never used for the direct encryption of sizable blocks of data, but are limited to relatively small blocks. One of the most important uses of a public-key cryptosystem is to encrypt secret keys for distribution. We see many specific examples of this in Part Five. Here, we discuss general principles and typical approaches.

Simple Secret Key Distribution

An extremely simple scheme was put forward by Merkle [MERK79], as illustrated in Figure 15.3. If A wishes to communicate with B, the following procedure is employed:

1. A generates a public/private key pair $\{PU_a, PR_a\}$ and transmits a message to B consisting of PU_a and an identifier of A, ID_A .
2. B generates a secret key, K_s , and transmits it to A, which is encrypted with A's public key.
3. A computes $D(PR_a, E(PU_a, K_s))$ to recover the secret key. Because only A can decrypt the message, only A and B will know the identity of K_s .
4. A discards PU_a and PR_a and B discards PU_a .

A and B can now securely communicate using conventional encryption and the session key K_s . At the completion of the exchange, both A and B discard K_s . Despite its simplicity, this is an attractive protocol. No keys exist before the start of the communication and none exist after the completion of communication. Thus, the risk of compromise of the keys is minimal. At the same time, the communication is secure from eavesdropping.

The protocol depicted in Figure 15.3 is insecure against an adversary who can intercept messages and then either relay the intercepted message or substitute another message (see Figure 1.3c). Such an attack is known as a **man-in-the-middle attack** [RIVE84]. We saw this type of attack in Chapter 10 (Figure 10.2). In the present case, if an adversary, D, has control of the intervening communication channel, then D can compromise the communication in the following fashion without being detected (Figure 15.4).

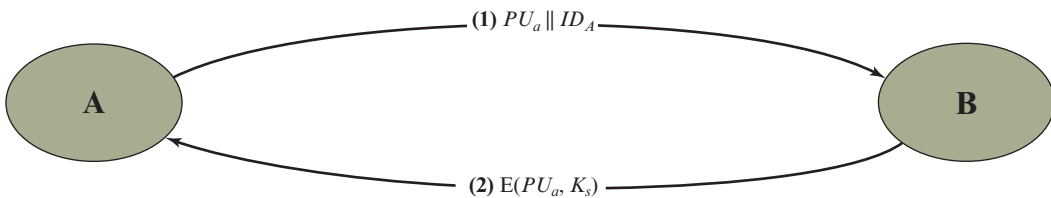

Figure 15.3 Simple Use of Public-Key Encryption to Establish a Session Key

1. A generates a public/private key pair $\{PU_a, PR_a\}$ and transmits a message intended for B consisting of PU_a and an identifier of A, ID_A .
2. D intercepts the message, creates its own public/private key pair $\{PU_d, PR_d\}$ and transmits $PU_d || ID_A$ to B.
3. B generates a secret key, K_s , and transmits $E(PU_d, K_s)$.
4. D intercepts the message and learns K_s by computing $D(PR_d, E(PU_d, K_s))$.
5. D transmits $E(PU_a, K_s)$ to A.

The result is that both A and B know K_s and are unaware that K_s has also been revealed to D. A and B can now exchange messages using K_s . D no longer actively

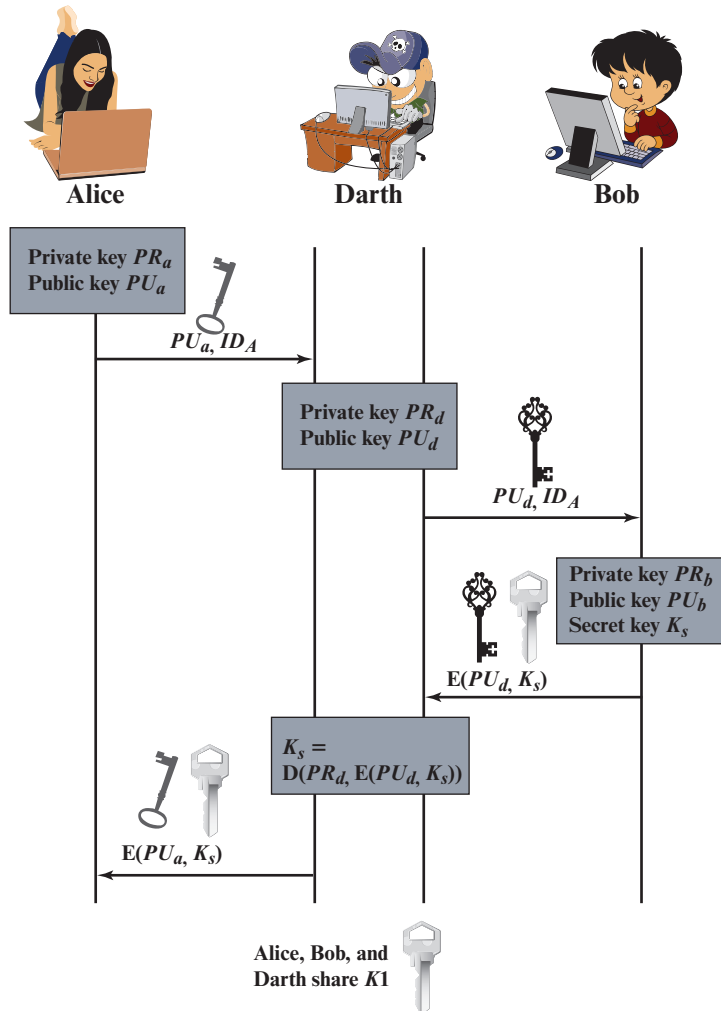

Figure 15.4 Another Man-in-the-Middle Attack

interferes with the communications channel but simply eavesdrops. Knowing K_s , D can decrypt all messages, and both A and B are unaware of the problem. Thus, this simple protocol is only useful in an environment where the only threat is eavesdropping.

Secret Key Distribution with Confidentiality and Authentication

Figure 15.5, based on an approach suggested in [NEED78], provides protection against both active and passive attacks. We begin at a point when it is assumed that A and B have exchanged public keys by one of the schemes described subsequently in this chapter. Then the following steps occur.

1. A uses B's public key to encrypt a message to B containing an identifier of A (ID_A) and a nonce (N_1), which is used to identify this transaction uniquely.
2. B sends a message to A encrypted with PU_a and containing A's nonce (N_1) as well as a new nonce generated by B (N_2). Because only B could have decrypted message (1), the presence of N_1 in message (2) assures A that the correspondent is B.
3. A returns N_2 , encrypted using B's public key, to assure B that its correspondent is A.
4. A selects a secret key K_s and sends $M = E(PU_b, E(PR_a, K_s))$ to B. Encryption of this message with B's public key ensures that only B can read it; encryption with A's private key ensures that only A could have sent it.
5. B computes $D(PU_a, D(PR_b, M))$ to recover the secret key.

The result is that this scheme ensures both confidentiality and authentication in the exchange of a secret key.

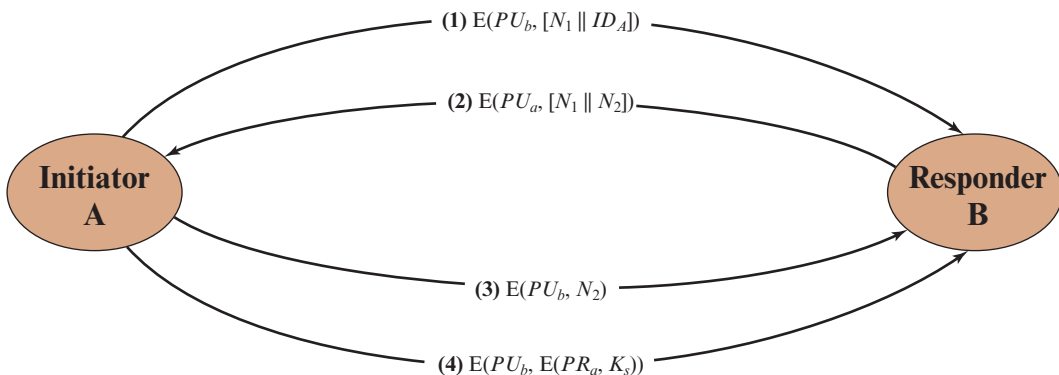

Figure 15.5 Public-Key Distribution of Secret Keys

15.3 DISTRIBUTION OF PUBLIC KEYS

Several techniques have been proposed for the distribution of public keys. Virtually all these proposals can be grouped into the following general schemes:

- Public announcement
- Publicly available directory
- Public-key authority
- Public-key certificates

Public Announcement of Public Keys

On the face of it, the point of public-key encryption is that the public key is public. Thus, if there is some broadly accepted public-key algorithm, such as RSA, any participant can send his or her public key to any other participant or broadcast the key to the community at large (Figure 15.6).

Although this approach is convenient, it has a major weakness. Anyone can forge such a public announcement. That is, some user could pretend to be user A and send a public key to another participant or broadcast such a public key. Until such time as user A discovers the forgery and alerts other participants, the forger is able to read all encrypted messages intended for A and can use the forged keys for authentication (see Figure 9.3).

Publicly Available Directory

A greater degree of security can be achieved by maintaining a publicly available dynamic directory of public keys. Maintenance and distribution of the public directory would have to be the responsibility of some trusted entity or organization (Figure 15.7). Such a scheme would include the following elements:

1. The authority maintains a directory with a {name, public key} entry for each participant.
2. Each participant registers a public key with the directory authority. Registration would have to be in person or by some form of secure authenticated communication.



Figure 15.6 Uncontrolled Public-Key Distribution

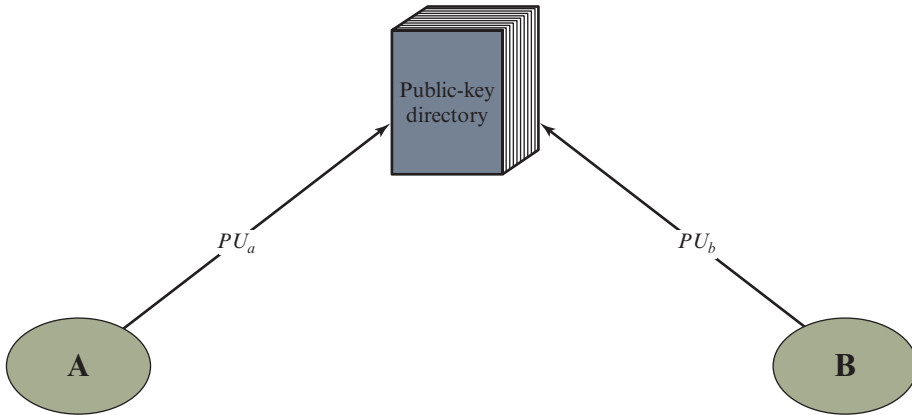

Figure 15.7 Public-Key Publication

3. A participant may replace the existing key with a new one at any time, either because of the desire to replace a public key that has already been used for a large amount of data, or because the corresponding private key has been compromised in some way.
4. Participants could also access the directory electronically. For this purpose, secure, authenticated communication from the authority to the participant is mandatory.

This scheme is clearly more secure than individual public announcements but still has vulnerabilities. If an adversary succeeds in obtaining or computing the private key of the directory authority, the adversary could authoritatively pass out counterfeit public keys and subsequently impersonate any participant and eavesdrop on messages sent to any participant. Another way to achieve the same end is for the adversary to tamper with the records kept by the authority.

Public-Key Authority

Stronger security for public-key distribution can be achieved by providing tighter control over the distribution of public keys from the directory. A typical scenario is illustrated in Figure 15.8, which is based on a figure in [POPE79]. As before, the scenario assumes that a central authority maintains a dynamic directory of public keys of all participants. In addition, each participant reliably knows a public key for the authority, with only the authority knowing the corresponding private key. The following steps (matched by number to Figure 15.8) occur.

1. A sends a timestamped message to the public-key authority containing a request for the current public key of B.
2. The authority responds with a message that is encrypted using the authority's private key, PR_{auth} . Thus, A is able to decrypt the message using the authority's public key. Therefore, A is assured that the message originated with the authority. The message includes the following:

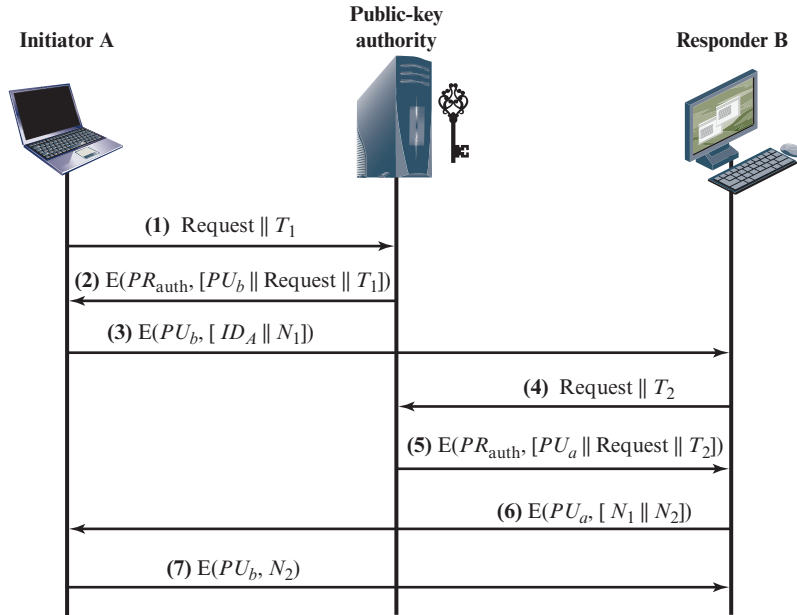

Figure 15.8 Public-Key Distribution Scenario

- B's public key, PU_b , which A can use to encrypt messages destined for B
 - The original request used to enable A to match this response with the corresponding earlier request and to verify that the original request was not altered before reception by the authority
 - The original timestamp given so A can determine that this is not an old message from the authority containing a key other than B's current public key
3. A stores B's public key and also uses it to encrypt a message to B containing an identifier of A (ID_A) and a nonce (N_1), which is used to identify this transaction uniquely.
 - 4, 5. B retrieves A's public key from the authority in the same manner as A retrieved B's public key.

At this point, public keys have been securely delivered to A and B, and they may begin their protected exchange. However, two additional steps are desirable:
 6. B sends a message to A encrypted with PU_a and containing A's nonce (N_1) as well as a new nonce generated by B (N_2). Because only B could have decrypted message (3), the presence of N_1 in message (6) assures A that the correspondent is B.
 7. A returns N_2 , which is encrypted using B's public key, to assure B that its correspondent is A.

Thus, a total of seven messages are required. However, the initial five messages need be used only infrequently because both A and B can save the other's public key for future use—a technique known as caching. Periodically, a user should request fresh copies of the public keys of its correspondents to ensure currency.

Public-Key Certificates

The scenario of Figure 15.8 is attractive, yet it has some drawbacks. The public-key authority could be somewhat of a bottleneck in the system, for a user must appeal to the authority for a public key for every other user that it wishes to contact. As before, the directory of names and public keys maintained by the authority is vulnerable to tampering.

An alternative approach, first suggested by Kohnfelder [KOH78], is to use **certificates** that can be used by participants to exchange keys without contacting a public-key authority, in a way that is as reliable as if the keys were obtained directly from a public-key authority. In essence, a certificate consists of a public key, an identifier of the key owner, and the whole block signed by a trusted third party. Typically, the third party is a certificate authority, such as a government agency or a financial institution, that is trusted by the user community. A user can present his or her public key to the authority in a secure manner and obtain a certificate. The user can then publish the certificate. Anyone needing this user's public key can obtain the certificate and verify that it is valid by way of the attached trusted signature. A participant can also convey its key information to another by transmitting its certificate. Other participants can verify that the certificate was created by the authority. We can place the following requirements on this scheme:

1. Any participant can read a certificate to determine the name and public key of the certificate's owner.
2. Any participant can verify that the certificate originated from the certificate authority and is not counterfeit.
3. Only the certificate authority can create and update certificates.

These requirements are satisfied by the original proposal in [KOH78]. Denning [DEN83] added the following additional requirement:

4. Any participant can verify the time validity of the certificate.

A certificate scheme is illustrated in Figure 15.9. Each participant applies to the certificate authority, supplying a public key and requesting a certificate. Application must be in person or by some form of secure authenticated communication. For participant A, the authority provides a certificate of the form

$$C_A = E(PR_{\text{auth}}, [T \| ID_A \| PU_a])$$

where PR_{auth} is the private key used by the authority and T is a timestamp. A may then pass this certificate on to any other participant, who reads and verifies the certificate as follows:

$$D(PU_{\text{auth}}, C_A) = D(PU_{\text{auth}}, E(PR_{\text{auth}}, [T \| ID_A \| PU_a])) = (T \| ID_A \| PU_a)$$

The recipient uses the authority's public key, PU_{auth} , to decrypt the certificate. Because the certificate is readable only using the authority's public key, this verifies that the certificate came from the certificate authority. The elements ID_A and PU_a provide the recipient with the name and public key of the certificate's holder. The timestamp T validates the currency of the certificate. The timestamp counters the following scenario. A's private key is learned by an adversary. A generates a new

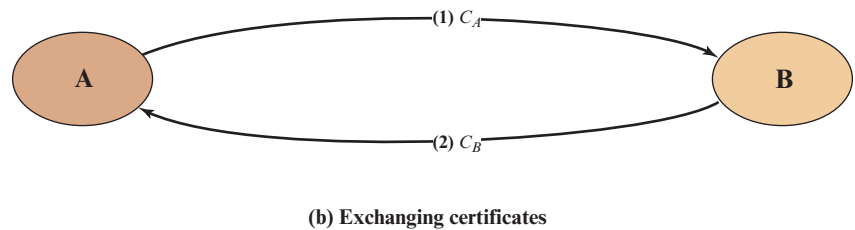
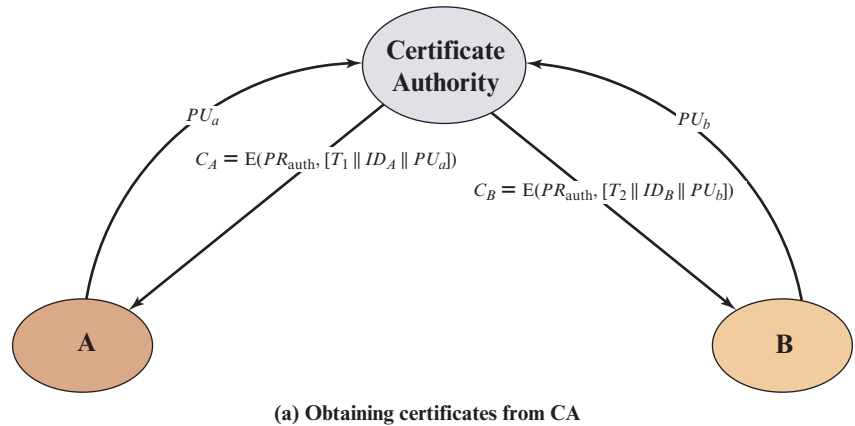

Figure 15.9 Exchange of Public-Key Certificates

private/public key pair and applies to the certificate authority for a new certificate. Meanwhile, the adversary replays the old certificate to B. If B then encrypts messages using the compromised old public key, the adversary can read those messages.

In this context, the compromise of a private key is comparable to the loss of a credit card. The owner cancels the credit card number but is at risk until all possible communicants are aware that the old credit card is obsolete. Thus, the timestamp serves as something like an expiration date. If a certificate is sufficiently old, it is assumed to be expired.

One scheme has become universally accepted for formatting public-key certificates: the X.509 standard. X.509 certificates are used in most network security applications, including IP security, transport layer security (TLS), and S/MIME, all of which are discussed in Part Six. X.509 is examined in detail in the next section.

15.4 X.509 CERTIFICATES

ITU-T recommendation X.509 is part of the X.500 series of recommendations that define a directory service. The directory is, in effect, a server or distributed set of servers that maintains a database of information about users. The information includes a mapping from user name to network address, as well as other attributes and information about the users.

X.509 defines a framework for the provision of authentication services by the X.500 directory to its users. The directory may serve as a repository of public-key certificates of the type discussed in Section 15.3. Each certificate contains the public key of a user and is signed with the private key of a trusted certification authority. In addition, X.509 defines alternative authentication protocols based on the use of public-key certificates.

X.509 is an important standard because the certificate structure and authentication protocols defined in X.509 are used in a variety of contexts. For example, the X.509 certificate format is used in S/MIME (Chapter 21), IP Security (Chapter 22), and SSL/TLS (Chapter 19).

X.509 was initially issued in 1988. The standard was subsequently revised in 1993 to address some of the security concerns documented in [IANS90] and [MITC90]. The standard is currently at edition eight, issued in 2016.

X.509 is based on the use of public-key cryptography and digital signatures. The standard does not dictate the use of a specific digital signature algorithm nor a specific hash function. Figure 15.10 illustrates the overall X.509 scheme for generation of a public-key certificate. The certificate for Bob's public key includes unique identifying information for Bob, Bob's public key, and identifying information about the CA, plus other information as explained subsequently. This information is then signed by computing a hash value of the information and generating a digital signature using the hash value and the CA's private key. Bob can then either broadcast this certificate to other users, or attach the certificate to any document or data block he signs. Anyone who needs to use Bob's public key can be assured that the public key contained in Bob's certificate is valid because the certificate is signed by the trusted CA.

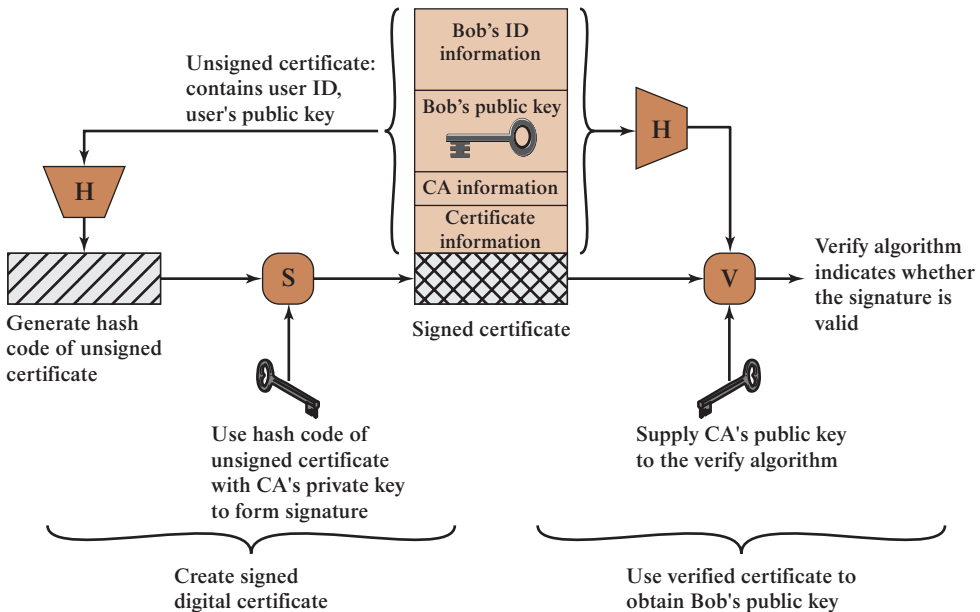

Figure 15.10 X.509 Public-Key Certificate Use

Certificates

The heart of the X.509 scheme is the **public-key certificate** associated with each user. These user certificates are assumed to be created by some trusted certification authority (CA) and placed in the directory by the CA or by the user. The directory server itself is not responsible for the creation of public keys or for the certification function; it merely provides an easily accessible location for users to obtain certificates.

Figure 15.11a shows the general format of a certificate, which includes the following elements.

- **Version:** Differentiates among successive versions of the certificate format; the default is version 1. If the *issuer unique identifier* or *subject unique identifier* are present, the value must be version 2. If one or more extensions are present, the version must be version 3. Although the X.509 specification is currently at version 7, no changes have been made to the fields that make up the certificate since version 3.
- **Serial number:** An integer value unique within the issuing CA that is unambiguously associated with this certificate.
- **Signature algorithm identifier:** The algorithm used to sign the certificate together with any associated parameters. Because this information is repeated in the signature field at the end of the certificate, this field has little, if any, utility.
- **Issuer name:** X.500 name of the CA that created and signed this certificate.

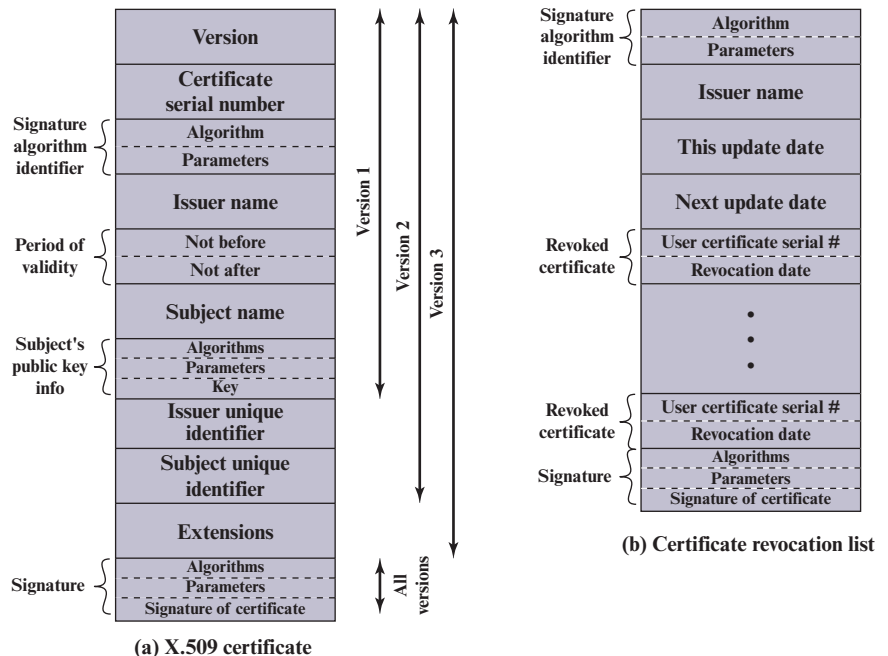

Figure 15.11 X.509 Formats

- **Period of validity:** Consists of two dates: the first and last on which the certificate is valid.
- **Subject name:** The name of the user to whom this certificate refers. That is, this certificate certifies the public key of the subject who holds the corresponding private key.
- **Subject's public-key information:** The public key of the subject, plus an identifier of the algorithm for which this key is to be used, together with any associated parameters.
- **Issuer unique identifier:** An optional-bit string field used to identify uniquely the issuing CA in the event the X.500 name has been reused for different entities.
- **Subject unique identifier:** An optional-bit string field used to identify uniquely the subject in the event the X.500 name has been reused for different entities.
- **Extensions:** A set of one or more extension fields. Extensions were added in version 3 and are discussed later in this section.
- **Signature:** Covers all of the other fields of the certificate. One component of this field is the digital signature applied to the other fields of the certificate. This field includes the signature algorithm identifier.

The unique identifier fields were added in version 2 to handle the possible reuse of subject and/or issuer names over time. These fields are rarely used.

The standard uses the following notation to define a certificate:

$$CA \ll A \gg = CA \{V, SN, AI, CA, UCA, A, UA, Ap, T^A\}$$

where

- $Y \ll X \gg$ = the certificate of user X issued by certification authority Y
- $Y \{I\}$ = the signing of I by Y. It consists of I with an encrypted hash code appended
- V = version of the certificate
- SN = serial number of the certificate
- AI = identifier of the algorithm used to sign the certificate
- CA = name of certificate authority
- UCA = optional unique identifier of the CA
- A = name of user A
- UA = optional unique identifier of the user A
- Ap = public key of user A
- T^A = period of validity of the certificate

The CA signs the certificate with its private key. If the corresponding public key is known to a user, then that user can verify that a certificate signed by the CA is valid. This is the typical digital signature approach illustrated in Figure 13.2.

OBTAINING A USER'S CERTIFICATE User certificates generated by a CA have the following characteristics:

- Any user with access to the public key of the CA can verify the user public key that was certified.
- No party other than the certification authority can modify the certificate without this being detected.

Because certificates are unforgeable, they can be placed in a directory without the need for the directory to make special efforts to protect them.

If all users subscribe to the same CA, then there is a common trust of that CA. All user certificates can be placed in the directory for access by all users. In addition, a user can transmit his or her certificate directly to other users. In either case, once B is in possession of A's certificate, B has confidence that messages it encrypts with A's public key will be secure from eavesdropping and that messages signed with A's private key are unforgeable.

If there is a large community of users, it may not be practical for all users to subscribe to the same CA. Because it is the CA that signs certificates, each participating user must have a copy of the CA's own public key to verify signatures. This public key must be provided to each user in an absolutely secure (with respect to integrity and authenticity) way so that the user has confidence in the associated certificates. Thus, with many users, it may be more practical for there to be a number of CAs, each of which securely provides its public key to some fraction of the users.

Now suppose that A has obtained a certificate from certification authority X_1 and B has obtained a certificate from CA X_2 . If A does not securely know the public key of X_2 , then B's certificate, issued by X_2 , is useless to A. A can read B's certificate, but A cannot verify the signature. However, if the two CAs have securely exchanged their own public keys, the following procedure will enable A to obtain B's public key.

Step 1 A obtains from the directory the certificate of X_2 signed by X_1 . Because A securely knows X_1 's public key, A can obtain X_2 's public key from its certificate and verify it by means of X_1 's signature on the certificate.

Step 2 A then goes back to the directory and obtains the certificate of B signed by X_2 . Because A now has a trusted copy of X_2 's public key, A can verify the signature and securely obtain B's public key.

A has used a chain of certificates to obtain B's public key. In the notation of X.509, this chain is expressed as

$$X_1 \ll X_2 \gg X_2 \ll B \gg$$

In the same fashion, B can obtain A's public key with the reverse chain:

$$X_2 \ll X_1 \gg X_1 \ll A \gg$$

This scheme need not be limited to a chain of two certificates. An arbitrarily long path of CAs can be followed to produce a chain. A chain with N elements would be expressed as

$$X_1 \ll X_2 \gg X_2 \ll X_3 \gg \dots X_N \ll B \gg$$

In this case, each pair of CAs in the chain (X_i, X_{i+1}) must have created certificates for each other.

All these certificates of CAs by CAs need to appear in the directory, and the user needs to know how they are linked to follow a path to another user's public-key certificate. X.509 suggests that CAs be arranged in a hierarchy so that navigation is straightforward.

Figure 15.12, taken from X.509, is an example of such a hierarchy. The connected circles indicate the hierarchical relationship among the CAs; the associated boxes indicate certificates maintained in the directory for each CA entry. The directory entry for each CA includes two types of certificates:

- **Forward certificates:** Certificates of X generated by other CAs
- **Reverse certificates:** Certificates generated by X that are the certificates of other CAs

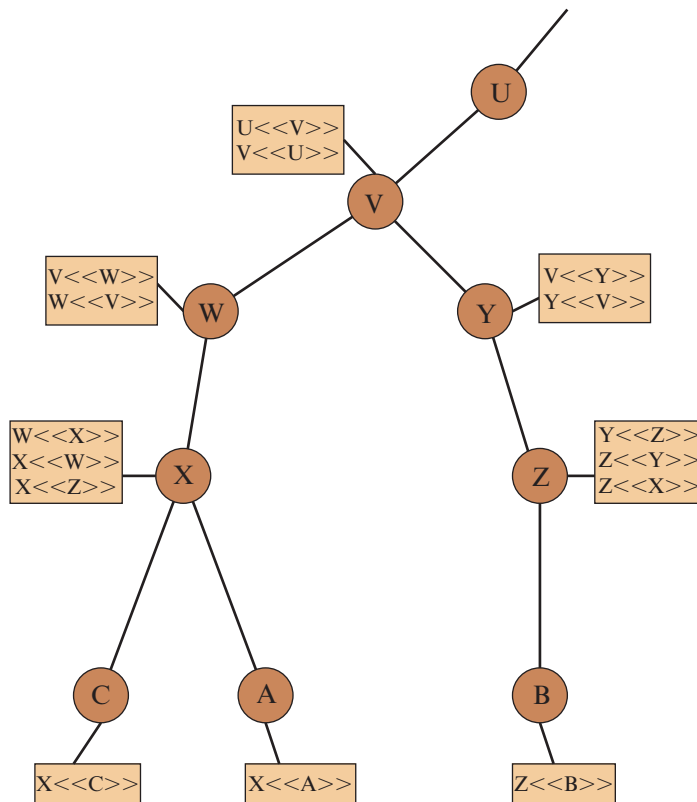

Figure 15.12 X.509 Hierarchy: A Hypothetical Example

In this example, user A can acquire the following certificates from the directory to establish a certification path to B:

$$X \ll W \gg W \ll V \gg V \ll Y \gg Y \ll Z \gg Z \ll B \gg$$

When A has obtained these certificates, it can unwrap the certification path in sequence to recover a trusted copy of B's public key. Using this public key, A can send encrypted messages to B. If A wishes to receive encrypted messages back from B, or to sign messages sent to B, then B will require A's public key, which can be obtained from the following certification path:

$$Z \ll Y \gg Y \ll V \gg V \ll W \gg W \ll X \gg X \ll A \gg$$

B can obtain this set of certificates from the directory, or A can provide them as part of its initial message to B.

REVOCATION OF CERTIFICATES Recall from Figure 15.11 that each certificate includes a period of validity, much like a credit card. Typically, a new certificate is issued just before the expiration of the old one. In addition, it may be desirable on occasion to revoke a certificate before it expires, for one of the following reasons.

1. The user's private key is assumed to be compromised.
2. The user is no longer certified by this CA. Reasons for this include that the subject's name has changed, the certificate is superseded, or the certificate was not issued in conformance with the CA's policies.
3. The CA's certificate is assumed to be compromised.

Each CA must maintain a list consisting of all revoked but not expired certificates issued by that CA, including both those issued to users and to other CAs. These lists should also be posted on the directory.

Each certificate revocation list (CRL) posted to the directory is signed by the issuer and includes (Figure 15.11b) the issuer's name, the date the list was created, the date the next CRL is scheduled to be issued, and an entry for each revoked certificate. Each entry consists of the serial number of a certificate and revocation date for that certificate. Because serial numbers are unique within a CA, the serial number is sufficient to identify the certificate.

When a user receives a certificate in a message, the user must determine whether the certificate has been revoked. The user could check the directory each time a certificate is received. To avoid the delays (and possible costs) associated with directory searches, it is likely that the user would maintain a local cache of certificates and lists of revoked certificates.

X.509 Version 3

The X.509 version 2 format does not convey all of the information that recent design and implementation experience has shown to be needed. [FORD95] lists the following requirements not satisfied by version 2.

1. The subject field is inadequate to convey the identity of a key owner to a public-key user. X.509 names may be relatively short and lacking in obvious identification details that may be needed by the user.
2. The subject field is also inadequate for many applications, which typically recognize entities by an Internet email address, a URL, or some other Internet-related identification.
3. There is a need to indicate security policy information. This enables a security application or function, such as IPSec, to relate an X.509 certificate to a given policy.
4. There is a need to limit the damage that can result from a faulty or malicious CA by setting constraints on the applicability of a particular certificate.
5. It is important to be able to identify different keys used by the same owner at different times. This feature supports key lifecycle management: in particular, the ability to update key pairs for users and CAs on a regular basis or under exceptional circumstances.

Rather than continue to add fields to a fixed format, standards developers felt that a more flexible approach was needed. Thus, version 3 includes a number of optional extensions that may be added to the version 2 format. Each extension consists of an extension identifier, a criticality indicator, and an extension value. The criticality indicator indicates whether an extension can be safely ignored. If the indicator has a value of TRUE and an implementation does not recognize the extension, it must treat the certificate as invalid.

The certificate extensions fall into three main categories: key and policy information, subject and issuer attributes, and certification path constraints.

KEY AND POLICY INFORMATION These extensions convey additional information about the subject and issuer keys, plus indicators of certificate policy. A certificate policy is a named set of rules that indicates the applicability of a certificate to a particular community and/or class of application with common security requirements. For example, a policy might be applicable to the authentication of electronic data interchange (EDI) transactions for the trading of goods within a given price range.

This area includes:

- **Authority key identifier:** Identifies the public key to be used to verify the signature on this certificate or CRL. Enables distinct keys of the same CA to be differentiated. One use of this field is to handle CA key pair updating.
- **Subject key identifier:** Identifies the public key being certified. Useful for subject key pair updating. Also, a subject may have multiple key pairs and, correspondingly, different certificates for different purposes (e.g., digital signature and encryption key agreement).
- **Key usage:** Indicates a restriction imposed as to the purposes for which, and the policies under which, the certified public key may be used. May indicate one or more of the following: digital signature, nonrepudiation, key encryption,

data encryption, key agreement, CA signature verification on certificates, CA signature verification on CRLs.

- **Private-key usage period:** Indicates the period of use of the private key corresponding to the public key. Typically, the private key is used over a different period from the validity of the public key. For example, with digital signature keys, the usage period for the signing private key is typically shorter than that for the verifying public key.
- **Certificate policies:** Certificates may be used in environments where multiple policies apply. This extension lists policies that the certificate is recognized as supporting, together with optional qualifier information.
- **Policy mappings:** Used only in certificates for CAs issued by other CAs. Policy mappings allow an issuing CA to indicate that one or more of that issuer's policies can be considered equivalent to another policy used in the subject CA's domain.

CERTIFICATE SUBJECT AND ISSUER ATTRIBUTES These extensions support alternative names, in alternative formats, for a certificate subject or certificate issuer and can convey additional information about the certificate subject to increase a certificate user's confidence that the certificate subject is a particular person or entity. For example, information such as postal address, position within a corporation, or picture image may be required.

The extension fields in this area include:

- **Subject alternative name:** Contains one or more alternative names, using any of a variety of forms. This field is important for supporting certain applications, such as electronic mail, EDI, and IPSec, which may employ their own name forms.
- **Issuer alternative name:** Contains one or more alternative names, using any of a variety of forms.
- **Subject directory attributes:** Conveys any desired X.500 directory attribute values for the subject of this certificate.

CERTIFICATION PATH CONSTRAINTS These extensions allow constraint specifications to be included in certificates issued for CAs by other CAs. The constraints may restrict the types of certificates that can be issued by the subject CA or that may occur subsequently in a certification chain.

The extension fields in this area include:

- **Basic constraints:** Indicates if the subject may act as a CA. If so, a certification path length constraint may be specified.
- **Name constraints:** Indicates a name space within which all subject names in subsequent certificates in a certification path must be located.
- **Policy constraints:** Specifies constraints that may require explicit certificate policy identification or inhibit policy mapping for the remainder of the certification path.

15.5 PUBLIC-KEY INFRASTRUCTURE

NIST SP 800-32 (*Introduction to Public Key Technology and the Federal PKI Infrastructure*) defines a public-key infrastructure (PKI) as a set of policies, processes, server platforms, software, and workstations used for the purpose of administering certificates and public–private key pairs, including the ability to issue, maintain, and revoke public key certificates. The principal objective for developing a PKI is to enable secure, convenient, and efficient acquisition of public keys.

A PKI architecture defines the organization and interrelationships among CAs and PKI users. PKI architectures satisfy the following requirements:

1. Any participant can read a certificate to determine the name and public key of the certificate's owner.
2. Any participant can verify that the certificate originated from the certificate authority and is not counterfeit.
3. Only the certificate authority can create and update certificates.
4. Any participant can verify the currency of the certificate.

Figure 15.13 provides a typical architecture for a PKI. The essential components are:

- **End entity:** This can be an end user; a device, such as a router or server; a process; or any item that can be identified in the subject name of a public key certificate. End entities can also be consumers of PKI-related services and, in some cases, providers of PKI-related services. For example, a Registration Authority is considered to be an end entity from the point of view of the Certification Authority.
- **Certification authority (CA):** An authority trusted by one or more users to create and assign public key certificates. Optionally the certification authority may create the subjects' keys. CAs digitally sign public key certificates, which effectively binds the subject's name to the public key. CAs are also responsible for issuing Certificate Revocation Lists (CRLs). The CRL identifies certificates previously issued by the CA that are revoked before their expiration date. A certificate could be revoked because the user's private key is assumed to be compromised, the user is no longer certified by this CA, or the certificate is assumed to be compromised.
- **Registration authority (RA):** An optional component that can be used to offload many of the administrative functions that a CA ordinarily assumes. The RA is normally associated with the end entity registration process. This includes the verification of the identity of the end entity attempting to register with the PKI and obtain a certificate for its public key.
- **Repository:** Denotes any method for storing and retrieving PKI-related information, such as public key certificates and CRLs. A repository can be an X.500-based directory with client access via the Lightweight Directory Access Protocol (LDAP). It also can be something simple, such as a means for

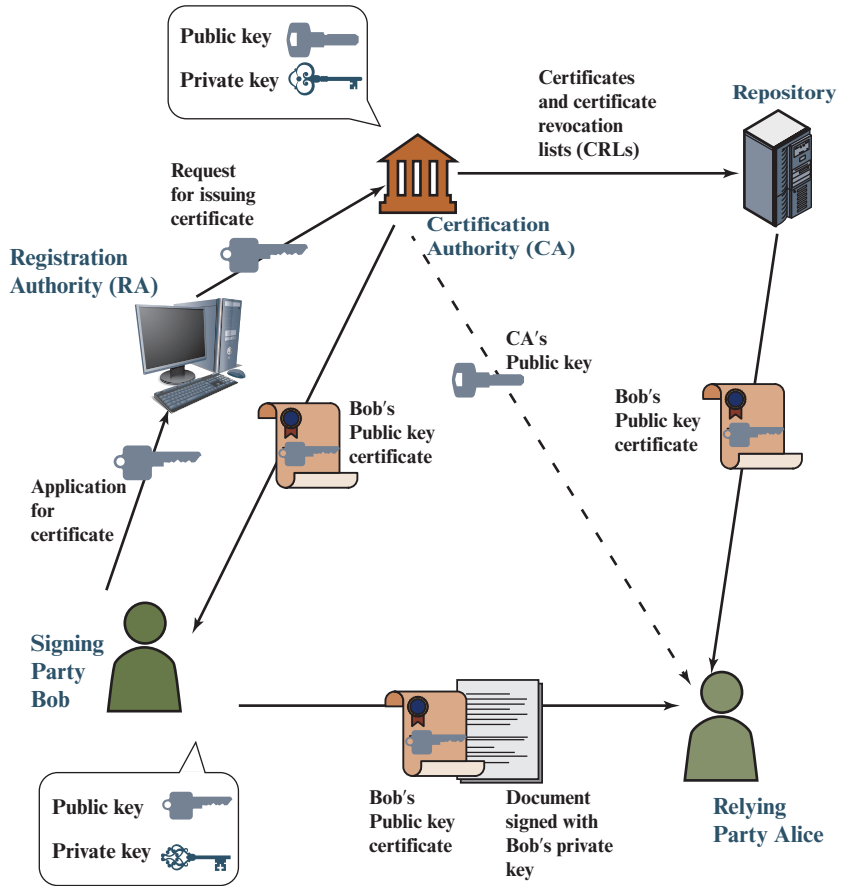

Figure 15.13 PKI Scenario

retrieval of a flat file on a remote server via the File Transfer Protocol (FTP) or the Hyper Text Transfer Protocol (HTTP).

- **Relying party:** Any user or agent that relies on the data in a certificate in making decisions.

Figure 15.13 illustrates the interaction of the various components. Consider a relying party Alice that needs to use Bob's public key. Alice must first obtain in a reliable, secure fashion a copy of the public key of the CA. This can be done in a number of ways and depends on the particular PKI architecture and enterprise policy. If Alice wishes to send encrypted data to Bob, Alice checks with the Repository to determine if Bob's certificate has been revoked, and if not obtains a copy of Bob's certificate. Alice can then use Bob's public key to encrypt data sent to Bob. Bob can also send a document to Alice signed with Bob's private key. Bob may include his certificate with the document or assume that Alice already has or can obtain the certificate. In either case, Alice first uses the CA's public key to verify that the certificate is valid, then uses Bob's public key (obtained from the certificate) to validate Bob's signature.

Rather than a single CA, an enterprise may need to rely on multiple CAs and multiple repositories. CAs can be organized in a hierarchical fashion, with a root CA that is widely trusted signing the public key certificate of subordinate CAs. Many root certificates are embedded in Web browsers so they have built-in trust of those CAs. Web servers, email clients, smartphones and many other types of hardware and software also support PKI and contain trusted root certificates from the major CAs.

15.6 KEY TERMS, REVIEW QUESTIONS, AND PROBLEMS

Key Terms

end-to-end encryption key distribution key distribution center (KDC)	key management man-in-the-middle attack master key	public-key certificate
--	--	------------------------

Review Questions

- 15.1** Explain why man-in-the-middle attacks are ineffective on the secret key distribution protocol discussed in Figure 15.8.
- 15.2** What is the difference between a session key and a master key?
- 15.3** What is a key distribution center?
- 15.4** What is one role that nonces play in key distribution using public-key cryptography?
- 15.5** List four requirements for the distribution of public keys using the public-key certificates scheme.
- 15.6** Discuss the potential security issues that arise due to a public-key–directory-based system.
- 15.7** What is a public-key certificate?
- 15.8** What are the requirements for the use of a public-key certificate scheme?
- 15.9** What is the purpose of the X.509 standard?
- 15.10** What types of certificates does an X.509 CA’s directory entry contain?
- 15.11** What is a certificate revocation list?

Problems

- 15.1** One local area network vendor provides a key distribution facility, as illustrated in Figure 15.14. Describe the operation of the scheme.
- 15.2** “We are under great pressure, Holmes.” Detective Lestrade looked nervous. “We have learned that copies of sensitive government documents are stored in computers of one foreign embassy here in London. Normally these documents exist in electronic form only on a selected few government computers that satisfy the most stringent security requirements. However, sometimes they must be sent through the network connecting all government computers. But all messages in this network are encrypted using a top-secret encryption algorithm certified by our best crypto experts. Even the NSA and the KGB are unable to break it. And now these documents have appeared in hands of diplomats of a small, otherwise insignificant, country. And we have no idea how it could happen.”

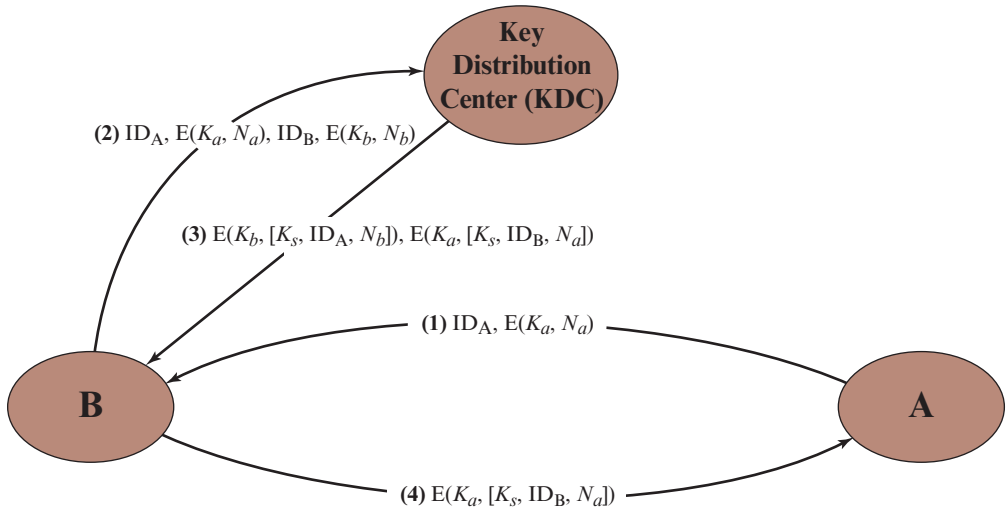

Figure 15.14 Figure for Problem 15.1

“But you do have some suspicion who did it, do you?” asked Holmes.

“Yes, we did some routine investigation. There is a man who has legal access to one of the government computers and has frequent contacts with diplomats from the embassy. But the computer he has access to is not one of the trusted ones where these documents are normally stored. He is the suspect, but we have no idea how he could obtain copies of the documents. Even if he could obtain a copy of an encrypted document, he couldn’t decrypt it.”

“Hmm, please describe the communication protocol used on the network.” Holmes opened his eyes, thus proving that he had followed Lestrade’s talk with an attention that contrasted with his sleepy look.

“Well, the protocol is as follows. Each node N of the network has been assigned a unique secret key K_n . This key is used to secure communication between the node and a trusted server. That is, all the keys are stored also on the server. User A, wishing to send a secret message M to user B, initiates the following protocol:

1. A generates a random number R and sends to the server his name A, destination B, and $E(K_a, R)$.
2. Server responds by sending $E(K_b, R)$ to A.
3. A sends $E(R, M)$ together with $E(K_b, R)$ to B.
4. B knows K_b , thus decrypts $E(K_b, R)$, to get R and will subsequently use R to decrypt $E(R, M)$ to get M .

You see that a random key is generated every time a message has to be sent. I admit the man could intercept messages sent between the top-secret trusted nodes, but I see no way he could decrypt them.”

“Well, I think you have your man, Lestrade. The protocol isn’t secure because the server doesn’t authenticate users who send him a request. Apparently designers of the protocol have believed that sending $E(K_x, R)$ implicitly authenticates user X as the sender, as only X (and the server) knows K_x . But you know that $E(K_x, R)$ can be intercepted and later replayed. Once you understand where the hole is, you will be able to obtain enough evidence by monitoring the man’s use of the computer he has access to. Most likely he works as follows. After intercepting $E(K_a, R)$ and $E(R, M)$

(see steps 1 and 3 of the protocol), the man, let's denote him as Z, will continue by pretending to be A and . . .

Finish the sentence for Holmes.

- 15.3** The 1988 version of X.509 lists properties that RSA keys must satisfy to be secure given current knowledge about the difficulty of factoring large numbers. The discussion concludes with a constraint on the public exponent and the modulus n :

It must be ensured that $e > \log_2(n)$ to prevent attack by taking the e th root mod n to disclose the plaintext.

Although the constraint is correct, the reason given for requiring it is incorrect. What is wrong with the reason given and what is the correct reason?

- 15.4** Determine the chain of certificates associated with the website *www.pearson.com*, describing the type of each CA.
- 15.5** NIST defines the term cryptoperiod as the time span during which a specific key is authorized for use or in which the keys for a given system or application may remain in effect. One document on key management uses the following time diagram for a shared secret key.

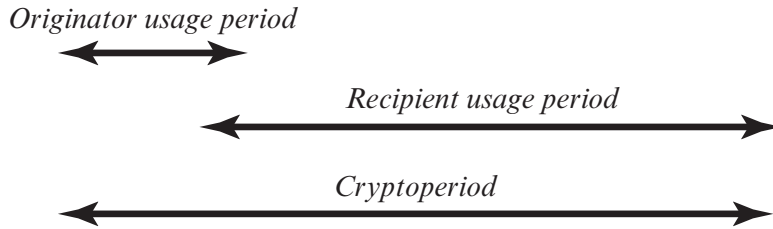

Explain the overlap by giving an example application in which the originator's usage period for the shared secret key begins before the recipient's usage period and also ends before the recipient's usage period.

- 15.6** Consider the following protocol, designed to let A and B decide on a fresh, shared session key K'_{AB} . We assume that they already share a long-term key K_{AB} .
1. $A \rightarrow B: A, N_A$.
 2. $B \rightarrow A: E(K_{AB}, [N_A, K'_{AB}])$
 3. $A \rightarrow B: E(K'_{AB}, N_A)$
- a.** We first try to understand the protocol designer's reasoning:
- Why would A and B believe after the protocol ran that they share K'_{AB} with the other party?
 - Why would they believe that this shared key is fresh?
- In both cases, you should explain both the reasons of both A and B, so your answer should complete the sentences
- A believes that she shares K'_{AB} with B since . . .
- B believes that he shares K'_{AB} with A since . . .
- A believes that K'_{AB} is fresh since . . .
- B believes that K'_{AB} is fresh since . . .
- b.** Assume now that A starts a run of this protocol with B. However, the connection is intercepted by the adversary C. Show how C can start a new run of the protocol using reflection, causing A to believe that she has agreed on a fresh key with B (in spite of the fact that she has only been communicating with C). Thus, in particular, the belief in (a) is false.
- c.** Propose a modification of the protocol that prevents this attack.
- 15.7** What are the core components of a PKI? Briefly describe each component.

15.8 Explain the problems with key management and how it affects symmetric cryptography.

15.9 What is the effect of adding the instruction EMKi

$$\text{EMK}_i: X \rightarrow E(KMH_i, X) \quad i = 0, 1$$

15.10 Suppose N different systems use the IBM Cryptographic Subsystem with host master keys $KMH[i]$ ($i = 1, 2, \dots, N$). Devise a method for communicating between systems without requiring the system to either share a common host master key or to divulge their individual host master keys. *Hint:* Each system needs three variants of its host master key.

15.11 The principal objective of the IBM Cryptographic Subsystem is to protect transmissions between a terminal and the processing system. Devise a procedure, perhaps adding instructions, which will allow the processor to generate a session key KS and distribute it to Terminal i and Terminal j without having to store a key-equivalent variable in the host.

CHAPTER 16

USER AUTHENTICATION

16.1 Remote User-Authentication Principles

- The NIST Model for Electronic User Authentication
- Means of Authentication
- Multifactor Authentication
- Mutual Authentication

16.2 Remote User-Authentication Using Symmetric Encryption

- Mutual Authentication

16.3 Kerberos

- Motivation
- Kerberos Version 4
- Kerberos Version 5

16.4 Remote User-Authentication Using Asymmetric Encryption

- Mutual Authentication
- One-Way Authentication

16.5 Federated Identity Management

- Identity Management
- Identity Federation

16.6 Key Terms, Review Questions, and Problems

LEARNING OBJECTIVES

After studying this chapter, you should be able to:

- ◆ Present an overview of techniques for remote user authentication using symmetric encryption.
- ◆ Give a presentation on Kerberos.
- ◆ Explain the differences between versions 4 and 5 of Kerberos.
- ◆ Describe the use of Kerberos in multiple realms.
- ◆ Present an overview of techniques for remote user authentication using asymmetric encryption.
- ◆ Understand the need for a federated identity management system.

This chapter examines some of the authentication functions that have been developed to support network-based user authentication. The chapter begins with an introduction to some of the concepts and key considerations for user authentication over a network or the Internet. The next section examines user-authentication protocols that rely on symmetric encryption. This is followed by a section on one of the earliest and also one of the most widely used authentication services: Kerberos. Next, the chapter looks at user-authentication protocols that rely on asymmetric encryption. This is followed by a discussion of the X.509 user-authentication protocol. Finally, the concept of federated identity is introduced.

16.1 REMOTE USER-AUTHENTICATION PRINCIPLES

User **authentication** is the process of determining whether some user or some application or process acting on behalf of a user is, in fact, who or what it declares itself to be. Authentication technology provides access control for systems by checking to see if a user's credentials match the credentials in a database of authorized users or in a data authentication server. Authentication enables organizations to keep their networks secure by permitting only authenticated users (or processes) to access its protected resources, which may include computer systems, networks, databases, websites, and other network-based applications or services.

Note that user authentication is distinct from message authentication. As defined in Chapter 12, message authentication is a procedure that allows communicating parties to verify that the contents of a received message have not been altered and that the source is authentic. This chapter is concerned solely with user authentication.

The NIST Model for Electronic User Authentication

NIST SP 800-63 (*Digital Identity Guidelines*) defines a general model for user authentication that involves a number of entities and procedures, as shown in Figure 16.1, based on SP-800-63. Three concepts are important in understanding this model:

- **Digital identity:** The unique representation of a subject engaged in an online transaction. The representation consists of an attribute or set of attributes that uniquely describe a subject within a given context of a digital service, but does not necessarily uniquely identify the subject in all contexts.
- **Identity proofing:** Establishes that a subject is who they claim to be to a stated level of certitude. This process involves collecting, validating, and verifying information about a person.
- **Digital authentication:** The process of determining the validity of one or more authenticators used to claim a digital identity. Authentication establishes that a subject attempting to access a digital service is in control of the technologies used to authenticate. Successful authentication provides reasonable risk-based assurances that the subject accessing the service today is the same as the subject that previously accessed the service.

Six entities are defined in Figure 16.1:

- **Credential service provider (CSP):** A trusted entity that issues or registers subscriber authenticators. For this purpose, the CSP establishes a digital credential for each subscriber and issues electronic credentials to subscribers. A CSP may be an independent third party or may issue credentials for its own use.
- **Verifier:** An entity that verifies the claimant’s identity by verifying the claimant’s possession and control of one or two authenticators using an authentication protocol. To do this, the verifier may also need to validate credentials that link the authenticator(s) to the subscriber’s identifier and check their status.

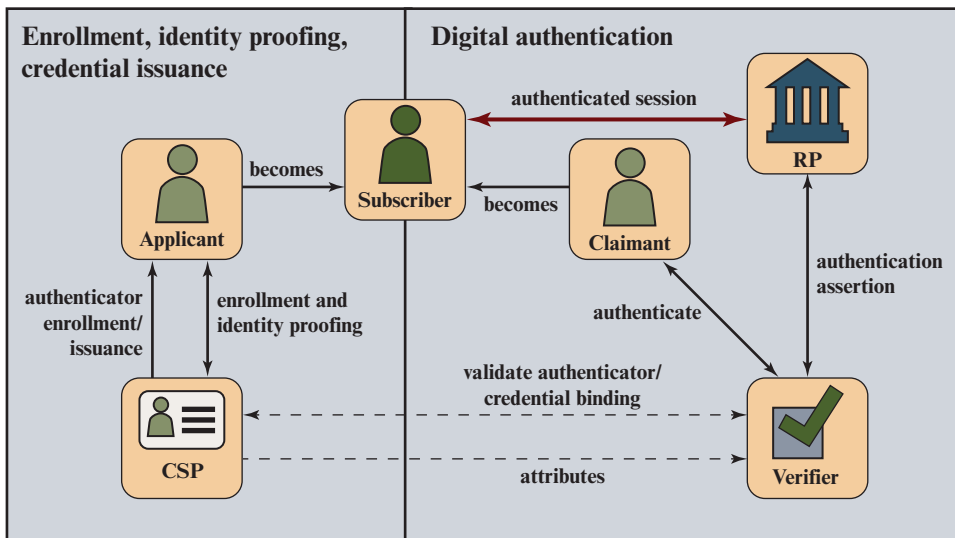

CSP = credential service provider
 RP = relying party

Figure 16.1 The NIST 800-63 Digital Identity Model

- **Relying party (RP):** An entity that relies upon the subscriber's authenticator(s) and credentials or a verifier's assertion of a claimant's identity, typically to process a transaction or grant access to information or a system.
- **Applicant:** A subject undergoing the processes of enrollment and identity proofing.
- **Claimant:** A subject whose identity is to be verified using one or more authentication protocols.
- **Subscriber:** A party who has received a credential or authenticator from a CSP.

The left-hand portion of Figure 16.1 illustrates the process whereby an applicant is enrolled into the system for purposes of accessing certain services and resources. First, the applicant presents to the CSP evidence of possession of the attributes to be associated with this digital identity. Upon successful proofing by the CSP, the applicant becomes a subscriber. Then, depending on the details of the overall authentication system, the CSP issues some sort of electronic credential to the subscriber. The credential is a data structure that authoritatively binds an identity and additional attributes to one or more authenticators possessed by a subscriber, and can be verified when presented to the verifier in an authentication transaction. The authenticator could be an encryption key or an encrypted password that identifies the subscriber. The authenticator may be issued by the CSP, generated directly by the subscriber, or provided by a third party. The authenticator and credential may be used in subsequent authentication events.

Once a user is registered as a subscriber, the actual authentication process can take place between the subscriber and one or more systems that perform authentication (right-hand portion of Figure 16.1). The party to be authenticated is called a claimant and the party verifying that identity is called a verifier. When a claimant successfully demonstrates possession and control of an authenticator to a verifier through an authentication protocol, the verifier can verify that the claimant is the subscriber named in the corresponding credential. The verifier passes on an assertion about the identity of the subscriber to the relying party (RP). That assertion includes identity information about a subscriber, such as the subscriber name, an identifier assigned at registration, or other subscriber attributes that were verified in the registration process. The RP can use the authenticated information provided by the verifier to make access control or authorization decisions.

In some cases, the verifier interacts with the CSP to access the credential that binds the subscriber's identity to their authenticator and to optionally obtain claimant attributes. In other cases, the verifier does not need to communicate in real time with the CSP to complete the authentication activity (e.g., some uses of digital certificates). Therefore, the dashed line between the verifier and the CSP represents a logical link between the two entities.

An implemented system for authentication will differ from or be more complex than this simplified model, but the model illustrates the key roles and functions needed for a secure authentication system.

Means of Authentication

There are three general means, or **authentication factors**, of authenticating a user's identity, which can be used alone or in combination:

- **Knowledge factor (something the individual knows):** Requires the user to demonstrate knowledge of secret information. Routinely used in single-layer authentication processes, knowledge factors can come in the form of passwords, passphrases, personal identification numbers (PINs), or answers to secret questions.
- **Possession factor (something the individual possesses):** Physical entity possessed by the authorized user to connect to the client computer or portal. This type of authenticator used to be referred to as a *token*, but that term is now deprecated. The term *hardware token* is a preferable alternative. Possession factors fall into two categories:

Connected hardware tokens are items that connect to a computer logically (e.g., via wireless) or physically in order to authenticate identity. Items such as smart cards, wireless tags, and USB tokens are common connected tokens used to serve as a possession factor.

Disconnected hardware tokens are items that do not directly connect to the client computer, instead requiring input from the individual attempting to sign in. Typically, a disconnected hardware token device will use a built-in screen to display authentication data that are then utilized by the user to sign in when prompted.

- **Inherence factor (something the individual is or does):** Refers to characteristics, called **biometrics**, that are unique or almost unique to the individual. These include static biometrics, such as fingerprint, retina, and face; and dynamic biometrics, such as voice, handwriting, and typing rhythm.

The specific items used during authentication, such as a password or hardware token, are referred to as **authenticators**. All of these methods, properly implemented and used, can provide secure user authentication. However, each method has problems (Table 16.1). An adversary may be able to guess or steal a password. Similarly, an adversary may be able to forge or steal a card. A user may forget a password or lose a card. A user may share a password or card with a colleague. Furthermore, there is a significant administrative overhead for managing password and card information on systems and securing such information on systems. With respect

Table 16.1 Authentication Factors

Factor	Examples	Properties
Knowledge	User ID Password PIN	Can be shared Many passwords easy to guess Can be forgotten
Possession	Smart Card Electronic Badge Electronic Key	Can be shared Can be duplicated (cloned) Can be lost or stolen
Inherence	Fingerprint Face Iris Voice print	Not possible to share False positives and false negatives possible Forging difficult

to biometric authenticators, there are a variety of problems, including dealing with false positives and false negatives, user acceptance, cost, security of the sensor itself, and convenience.

Multifactor Authentication

Multifactor authentication refers to the use of more than one of the authentication means in the preceding list (Figure 16.2). Typically, this strategy involves the use of authentication technologies from two of the classes of factors described above, such as a PIN plus a hardware token (knowledge factor plus possession factor) or a PIN and a biometric (knowledge factor plus inherence factor). Multifactor authentication will generally be more secure than the use of a single factor, because the failure modes for different factors are largely independent. So, for example, a hardware token might be lost or stolen, but the PIN required for use with the token would not be lost or stolen at the same time. This assumption is not always true, however. For example, a PIN attached to a hardware token is compromised at the same time that the token is lost or stolen. Nevertheless, multifactor authentication is an important means of reducing vulnerability.

Mutual Authentication

An important application area is that of mutual authentication protocols. Such protocols enable communicating parties to satisfy themselves mutually about each other's identity and to exchange session keys. This topic was examined in Chapter 14.

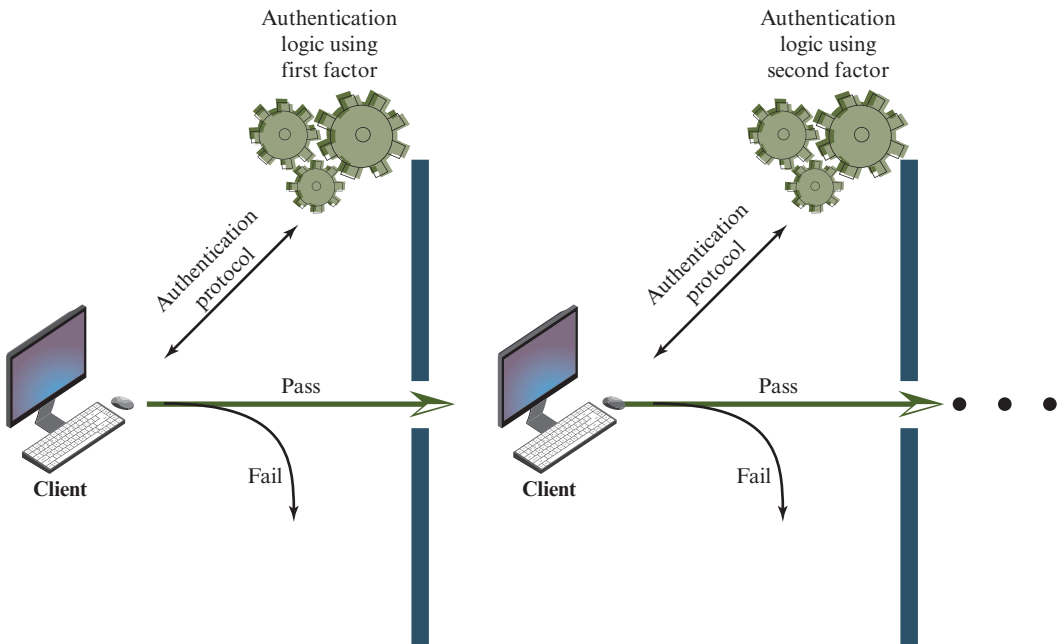

Figure 16.2 Multifactor Authentication

There, the focus was key distribution. We return to this topic here to consider the wider implications of authentication.

Central to the problem of authenticated key exchange are two issues: confidentiality and timeliness. To prevent masquerade and to prevent compromise of session keys, essential identification and session-key information must be communicated in encrypted form. This requires the prior existence of secret or public keys that can be used for this purpose. The second issue, timeliness, is important because of the threat of message replays. Such replays, at worst, could allow an opponent to compromise a session key or successfully impersonate another party. At minimum, a successful replay can disrupt operations by presenting parties with messages that appear genuine but are not.

[GONG93] lists the following examples of **replay attacks**:

1. The simplest replay attack is one in which the opponent simply copies a message and replays it later.
2. An opponent can replay a timestamped message within the valid time window. If both the original and the replay arrive within then time window, this incident can be logged.
3. As with example (2), an opponent can replay a timestamped message within the valid time window, but in addition, the opponent suppresses the original message. Thus, the repetition cannot be detected.
4. Another attack involves a backward replay without modification. This is a replay back to the message sender. This attack is possible if symmetric encryption is used and the sender cannot easily recognize the difference between messages sent and messages received on the basis of content.

One approach to coping with replay attacks is to attach a sequence number to each message used in an authentication exchange. A new message is accepted only if its sequence number is in the proper order. The difficulty with this approach is that it requires each party to keep track of the last sequence number for each claimant it has dealt with. Because of this overhead, sequence numbers are generally not used for authentication and key exchange. Instead, one of the following two general approaches is used:

- **Timestamps:** Party A accepts a message as fresh only if the message contains a **timestamp** that, in A's judgment, is close enough to A's knowledge of current time. This approach requires that clocks among the various participants be synchronized.
- **Challenge/response:** Party A, expecting a fresh message from B, first sends B a **nonce** (challenge) and requires that the subsequent message (response) received from B contain the correct nonce value.

It can be argued (e.g., [LAM92a]) that the timestamp approach should not be used for connection-oriented applications because of the inherent difficulties with this technique. First, some sort of protocol is needed to maintain synchronization among the various processor clocks. This protocol must be both fault tolerant, to cope with network errors, and secure, to cope with hostile attacks. Second, the opportunity for a successful attack will arise if there is a temporary loss of synchronization

resulting from a fault in the clock mechanism of one of the parties. Finally, because of the variable and unpredictable nature of network delays, distributed clocks cannot be expected to maintain precise synchronization. Therefore, any timestamp-based procedure must allow for a window of time sufficiently large to accommodate network delays yet sufficiently small to minimize the opportunity for attack.

On the other hand, the challenge-response approach is unsuitable for a connectionless type of application, because it requires the overhead of a handshake before any connectionless transmission, effectively negating the chief characteristic of a connectionless transaction. For such applications, reliance on some sort of secure time server and a consistent attempt by each party to keep its clocks in synchronization may be the best approach (e.g., [LAM92b]).

16.2 REMOTE USER-AUTHENTICATION USING SYMMETRIC ENCRYPTION

Mutual Authentication

As was discussed in Chapter 14, a two-level hierarchy of symmetric encryption keys can be used to provide confidentiality for communication in a distributed environment. In general, this strategy involves the use of a trusted key distribution center (KDC). Each party in the network shares a secret key, known as a master key, with the KDC. The KDC is responsible for generating keys to be used for a short time over a connection between two parties, known as session keys, and for distributing those keys using the master keys to protect the distribution. This approach is quite common. As an example, we look at the Kerberos system in Section 16.3. The discussion in this subsection is relevant to an understanding of the Kerberos mechanisms.

Needham and Schroeder [NEED78] put forth a protocol for secret key distribution using a KDC that includes authentication features. The protocol can be summarized as follows.¹

1. $A \rightarrow \text{KDC}: ID_A \parallel ID_B \parallel N_1$
2. $\text{KDC} \rightarrow A: E(K_a, [K_s \parallel ID_B \parallel N_1 \parallel E(K_b, [K_s \parallel ID_A])])$
3. $A \rightarrow B: E(K_b, [K_s \parallel ID_A])$
4. $B \rightarrow A: E(K_s, N_2)$
5. $A \rightarrow B: E(K_s, f(N_2))$ where $f()$ is a generic function that modifies the value of the nonce.

Secret keys K_a and K_b are shared between A and the KDC and B and the KDC, respectively. The purpose of the protocol is to distribute securely a session key K_s to A and B. Entity A securely acquires a new session key in step 2. The message in step 3 can be decrypted, and hence understood, only by B. Step 4 reflects B's knowledge of K_s , and step 5 assures B of A's knowledge of K_s and assures B that this is a fresh message because of the use of the nonce N_2 . The purpose of steps 4

¹The portion to the left of the colon indicates the sender and the receiver; the portion to the right indicates the contents of the message; the symbol \parallel indicates concatenation.

and 5 is to prevent a certain type of replay attack. In particular, if an opponent is able to capture the message in step 3 and replay it, this might in some fashion disrupt operations at B.

Despite the handshake of steps 4 and 5, the protocol is still vulnerable to a form of replay attack. Suppose that an opponent, X, has been able to compromise an old session key. Admittedly, this is a much more unlikely occurrence than that an opponent has simply observed and recorded step 3. Nevertheless, it is a potential security risk. X can impersonate A and trick B into using the old key by simply replaying step 3. Unless B remembers indefinitely all previous session keys used with A, B will be unable to determine that this is a replay. If X can intercept the handshake message in step 4, then it can impersonate A's response in step 5. From this point on, X can send bogus messages to B that appear to B to come from A using an authenticated session key.

Denning [DENN81, DENN82] proposes to overcome this weakness by a modification to the Needham/Schroeder protocol that includes the addition of a timestamp to steps 2 and 3. Her proposal assumes that the master keys, K_a and K_b , are secure, and it consists of the following steps.

1. $A \rightarrow \text{KDC}$: $ID_A \parallel ID_B$
2. $\text{KDC} \rightarrow A$: $E(K_a, [K_s \parallel ID_B \parallel T \parallel E(K_b, [K_s \parallel ID_A \parallel T])])$
3. $A \rightarrow B$: $E(K_b, [K_s \parallel ID_A \parallel T])$
4. $B \rightarrow A$: $E(K_s, N_1)$
5. $A \rightarrow B$: $E(K_s, f(N_1))$

T is a timestamp that assures A and B that the session key has only just been generated. Thus, both A and B know that the key distribution is a fresh exchange. A and B can verify timeliness by checking that

$$|\text{Clock} - T| < \Delta t_1 + \Delta t_2$$

where Δt_1 is the estimated normal discrepancy between the KDC's clock and the local clock (at A or B) and Δt_2 is the expected network delay time. Each node can set its clock against some standard reference source. Because the timestamp T is encrypted using the secure master keys, an opponent, even with knowledge of an old session key, cannot succeed because a replay of step 3 will be detected by B as untimely.

A final point: Steps 4 and 5 were not included in the original presentation [DENN81] but were added later [DENN82]. These steps confirm the receipt of the session key at B.

The Denning protocol seems to provide an increased degree of security compared to the Needham/Schroeder protocol. However, a new concern is raised: namely, that this new scheme requires reliance on clocks that are synchronized throughout the network. [GONG92] points out a risk involved. The risk is based on the fact that the distributed clocks can become unsynchronized as a result of sabotage on or faults in the clocks or the synchronization mechanism. The problem occurs when a sender's clock is ahead of the intended recipient's clock. In this case, an opponent can intercept a message from the sender and replay it later when the timestamp in the message becomes current at the recipient's

site. This replay could cause unexpected results. Gong refers to such attacks as suppress-replay attacks.

One way to counter suppress-replay attacks is to enforce the requirement that parties regularly check their clocks against the KDC's clock. The other alternative, which avoids the need for clock synchronization, is to rely on handshaking protocols using nonces. This latter alternative is not vulnerable to a suppress-replay attack, because the nonces the recipient will choose in the future are unpredictable to the sender. The Needham/Schroeder protocol relies on nonces only but, as we have seen, has other vulnerabilities.

In [KEHN92], an attempt is made to respond to the concerns about suppress-replay attacks and at the same time fix the problems in the Needham/Schroeder protocol. Subsequently, an inconsistency in this latter protocol was noted and an improved strategy was presented in [NEUM93a]. The protocol is

1. $A \rightarrow B$: $ID_A \parallel N_a$
2. $B \rightarrow KDC$: $ID_B \parallel N_b \parallel E(K_b, [ID_A \parallel N_a \parallel T_b])$
3. $KDC \rightarrow A$: $E(K_a, [ID_B \parallel N_a \parallel K_s \parallel T_b]) \parallel E(K_b, [ID_A \parallel K_s \parallel T_b]) \parallel N_b$
4. $A \rightarrow B$: $E(K_b, [ID_A \parallel K_s \parallel T_b]) \parallel E(K_s, N_b)$

Let us follow this exchange step by step.

1. A initiates the authentication exchange by generating a nonce, N_a , and sending that plus its identifier to B in plaintext. This nonce will be returned to A in an encrypted message that includes the session key, assuring A of its timeliness.
2. B alerts the KDC that a session key is needed. Its message to the KDC includes its identifier and a nonce, N_b . This nonce will be returned to B in an encrypted message that includes the session key, assuring B of its timeliness. B's message to the KDC also includes a block encrypted with the secret key shared by B and the KDC. This block is used to instruct the KDC to issue credentials to A; the block specifies the intended recipient of the credentials, a suggested expiration time for the credentials, and the nonce received from A.
3. The KDC passes on to A B's nonce and a block encrypted with the secret key that B shares with the KDC. The block serves as a "ticket" that can be used by A for subsequent authentications, as will be seen. The KDC also sends to A a block encrypted with the secret key shared by A and the KDC. This block verifies that B has received A's initial message (ID_B) and that this is a timely message and not a replay (N_a), and it provides A with a session key (K_s) and the time limit on its use (T_b).
4. A transmits the ticket to B, together with the B's nonce, the latter encrypted with the session key. The ticket provides B with the secret key that is used to decrypt $E(K_s, N_b)$ to recover the nonce. The fact that B's nonce is encrypted with the session key authenticates that the message came from A and is not a replay.

This protocol provides an effective, secure means for A and B to establish a session with a secure session key. Furthermore, the protocol leaves A in possession of a key that can be used for subsequent authentication to B, avoiding the

need to contact the authentication server repeatedly. Suppose that A and B establish a session using the aforementioned protocol and then conclude that session. Subsequently, but within the time limit established by the protocol, A desires a new session with B. The following protocol ensues:

1. $A \rightarrow B: E(K_b, [ID_A \| K_s \| T_b]) \| N'_a$
2. $B \rightarrow A: N'_b \| E(K_s, N'_a)$
3. $A \rightarrow B: E(K_s, N'_b)$

When B receives the message in step 1, it verifies that the ticket has not expired. The newly generated nonces N'_a and N'_b assure each party that there is no replay attack.

In all the foregoing, the time specified in T_b is a time relative to B's clock. Thus, this timestamp does not require synchronized clocks, because B checks only self-generated timestamps.

16.3 KERBEROS

Kerberos is an authentication service that addresses the following problem: Assume an open distributed environment in which users at workstations wish to access services on servers distributed throughout the network. We would like for servers to be able to restrict access to authorized users and to be able to authenticate requests for service. In this environment, a workstation cannot be trusted to identify its users correctly to network services. In particular, the following three threats exist:

1. A user may gain access to a particular workstation and pretend to be another user operating from that workstation.
2. A user may alter the network address of a workstation so that the requests sent from the altered workstation appear to come from the impersonated workstation.
3. A user may eavesdrop on exchanges and use a replay attack to gain entrance to a server or to disrupt operations.

In any of these cases, an unauthorized user may be able to gain access to services and data that he or she is not authorized to access. Rather than building in elaborate authentication protocols at each server, Kerberos provides a centralized **authentication server** whose function is to authenticate users to servers and servers to users. Unlike most other authentication schemes described in this book, Kerberos relies exclusively on symmetric encryption, making no use of public-key encryption.

The first widely used version of Kerberos was Version 4 [MILL88, STEI88]. Version 5 [KOHL94] corrects some of the security deficiencies of version 4 and has been issued as a proposed Internet Standard (RFC 4120 and RFC 4121).

We begin this section with a brief discussion of the motivation for the Kerberos approach. Then, because of the complexity of Kerberos, it is best to start with a description of the authentication protocol used in version 4. This enables us to see the essence of the Kerberos strategy without considering some of the details required to handle subtle security threats. Finally, we examine version 5.

Motivation

If a set of users is provided with dedicated personal computers that have no network connections, then a user's resources and files can be protected by physically securing each personal computer. When these users instead are served by a centralized time-sharing system, the time-sharing operating system must provide the security. The operating system can enforce access-control policies based on user identity and use the logon procedure to identify users.

Today, neither of these scenarios is typical. More common is a distributed architecture consisting of dedicated user workstations (clients) and distributed or centralized servers. In this environment, three approaches to security can be envisioned.

1. Rely on each individual client workstation to assure the identity of its user or users and rely on each server to enforce a security policy based on user identification (ID).
2. Require that client systems authenticate themselves to servers, but trust the client system concerning the identity of its user.
3. Require the user to prove his or her identity for each service invoked. Also require that servers prove their identity to clients.

In a small, closed environment in which all systems are owned and operated by a single organization, the first or perhaps the second strategy may suffice. But in a more open environment in which network connections to other machines are supported, the third approach is needed to protect user information and resources housed at the server. Kerberos supports this third approach. Kerberos assumes a distributed client/server architecture and employs one or more Kerberos servers to provide an authentication service.

The first published report on Kerberos [STEI88] listed the following requirements.

- **Secure:** A network eavesdropper should not be able to obtain the necessary information to impersonate a user. More generally, Kerberos should be strong enough that a potential opponent does not find it to be the weak link.
- **Reliable:** For all services that rely on Kerberos for access control, lack of availability of the Kerberos service means lack of availability of the supported services. Hence, Kerberos should be highly reliable and should employ a distributed server architecture with one system able to back up another.
- **Transparent:** Ideally, the user should not be aware that authentication is taking place beyond the requirement to enter a password.
- **Scalable:** The system should be capable of supporting large numbers of clients and servers. This suggests a modular, distributed architecture.

To support these requirements, the overall scheme of Kerberos is that of a trusted third-party authentication service that uses a protocol based on that proposed by Needham and Schroeder [NEED78], which was discussed in Section 16.2. It is trusted in the sense that clients and servers trust Kerberos to mediate their

mutual authentication. Assuming the Kerberos protocol is well designed, then the authentication service is secure if the Kerberos server itself is secure.

Kerberos Version 4

Version 4 of Kerberos makes use of DES, in a rather elaborate protocol, to provide the authentication service. Viewing the protocol as a whole, it is difficult to see the need for the many of its elements. Therefore, we adopt a strategy used by Bill Bryant of Project Athena [BRYA88] and build up to the full protocol by looking first at several hypothetical dialogues. Each successive dialogue adds additional complexity to counter security vulnerabilities revealed in the preceding dialogue.

After examining the protocol, we look at some other aspects of version 4.

A SIMPLE AUTHENTICATION DIALOGUE In an unprotected network environment, any client can apply to any server for service. The obvious security risk is that of impersonation. An opponent can pretend to be another client and obtain unauthorized privileges on server machines. To counter this threat, servers must be able to confirm the identities of clients who request service. Each server can be required to undertake this task for each client/server interaction, but in an open environment, this places a substantial burden on each server.

An alternative is to use an authentication server (AS) that knows the passwords of all users and stores these in a centralized database. In addition, the AS shares a unique secret key with each server. These keys have been distributed physically or in some other secure manner. Consider the following hypothetical dialogue:

$$\begin{aligned}
 (1) \text{ C} \rightarrow \text{AS}: & \quad ID_C \| P_C \| ID_V \\
 (2) \text{ AS} \rightarrow \text{C}: & \quad Ticket \\
 (3) \text{ C} \rightarrow \text{V}: & \quad ID_C \| Ticket \\
 Ticket = & \quad E(K_v, [ID_C \| AD_C \| ID_V])
 \end{aligned}$$

where

- C = client
- AS = authentication server
- V = server
- ID_C = identifier of user on C
- ID_V = identifier of V
- P_C = password of user on C
- AD_C = network address of C
- K_v = secret encryption key shared by AS and V

In this scenario, the user logs on to a workstation and requests access to server V. The client module C in the user's workstation requests the user's password and then sends a message to the AS that includes the user's ID, the server's ID, and the user's password. The AS checks its database to see if the user has supplied the proper password for this user ID and whether this user is permitted access to server V. If both

tests are passed, the AS accepts the user as authentic and must now convince the server that this user is authentic. To do so, the AS creates a ticket that contains the user's ID and network address and the server's ID. This ticket is encrypted using the secret key shared by the AS and this server. This ticket is then sent back to C. Because the ticket is encrypted, it cannot be altered by C or by an opponent.

With this ticket, C can now apply to V for service. C sends a message to V containing C's ID and the ticket. V decrypts the ticket and verifies that the user ID in the ticket is the same as the unencrypted user ID in the message. If these two match, the server considers the user authenticated and grants the requested service.

Each of the ingredients of message (3) is significant. The ticket is encrypted to prevent alteration or forgery. The server's ID (ID_V) is included in the ticket so that the server can verify that it has decrypted the ticket properly. ID_C is included in the ticket to indicate that this ticket has been issued on behalf of C. Finally, AD_C serves to counter the following threat. An opponent could capture the ticket transmitted in message (2), then use the name ID_C and transmit a message of form (3) from another workstation. The server would receive a valid ticket that matches the user ID and grant access to the user on that other workstation. To prevent this attack, the AS includes in the ticket the network address from which the original request came. Now the ticket is valid only if it is transmitted from the same workstation that initially requested the ticket.

A MORE SECURE AUTHENTICATION DIALOGUE Although the foregoing scenario solves some of the problems of authentication in an open network environment, problems remain. Two in particular stand out. First, we would like to minimize the number of times that a user has to enter a password. Suppose each ticket can be used only once. If user C logs on to a workstation in the morning and wishes to check his or her mail at a mail server, C must supply a password to get a ticket for the mail server. If C wishes to check the mail several times during the day, each attempt requires reentering the password. We can improve matters by saying that tickets are reusable. For a single logon session, the workstation can store the mail server ticket after it is received and use it on behalf of the user for multiple accesses to the mail server.

However, under this scheme, it remains the case that a user would need a new ticket for every different service. If a user wished to access a print server, a mail server, a file server, and so on, the first instance of each access would require a new ticket and hence require the user to enter the password.

The second problem is that the earlier scenario involved a plaintext transmission of the password [message (1)]. An eavesdropper could capture the password and use any service accessible to the victim.

To solve these additional problems, we introduce a scheme for avoiding plaintext passwords and a new server, known as the ticket-granting server (TGS). The new (but still hypothetical) scenario is as follows.

Once per user logon session:

(1) $C \rightarrow AS: ID_C || ID_{TGS}$

(2) $AS \rightarrow C: E(K_C, Ticket_{TGS})$

Once per type of service:

$$(3) C \rightarrow TGS: ID_C \parallel ID_V \parallel Ticket_{TGS}$$

$$(4) TGS \rightarrow C: Ticket_V$$

Once per service session:

$$(5) C \rightarrow V: ID_C \parallel Ticket_V$$

$$Ticket_{TGS} = E(K_{TGS}, [ID_C \parallel AD_C \parallel ID_{TGS} \parallel TS_1 \parallel Lifetime_1])$$

$$Ticket_V = E(K_V, [ID_C \parallel AD_C \parallel ID_V \parallel TS_2 \parallel Lifetime_2])$$

The new service, TGS, issues tickets to users who have been authenticated to AS. Thus, the user first requests a ticket-granting ticket ($Ticket_{TGS}$) from the AS. The client module in the user workstation saves this ticket. Each time the user requires access to a new service, the client applies to the TGS, using the ticket to authenticate itself. The TGS then grants a ticket for the particular service. The client saves each service-granting ticket and uses it to authenticate its user to a server each time a particular service is requested. Let us look at the details of this scheme:

1. The client requests a ticket-granting ticket on behalf of the user by sending its user's ID to the AS, together with the TGS ID, indicating a request to use the TGS service.
2. The AS responds with a ticket that is encrypted with a key that is derived from the user's password (K_C), which is already stored at the AS. When this response arrives at the client, the client prompts the user for his or her password, generates the key, and attempts to decrypt the incoming message. If the correct password is supplied, the ticket is successfully recovered.

Because only the correct user should know the password, only the correct user can recover the ticket. Thus, we have used the password to obtain credentials from Kerberos without having to transmit the password in plaintext. The ticket itself consists of the ID and network address of the user, and the ID of the TGS. This corresponds to the first scenario. The idea is that the client can use this ticket to request multiple service-granting tickets. So the ticket-granting ticket is to be reusable. However, we do not wish an opponent to be able to capture the ticket and use it. Consider the following scenario: An opponent captures the login ticket and waits until the user has logged off his or her workstation. Then the opponent either gains access to that workstation or configures his workstation with the same network address as that of the victim. The opponent would be able to reuse the ticket to spoof the TGS. To counter this, the ticket includes a timestamp, indicating the date and time at which the ticket was issued, and a lifetime, indicating the length of time for which the ticket is valid (e.g., eight hours). Thus, the client now has a reusable ticket and need not bother the user for a password for each new service request. Finally, note that the ticket-granting ticket is encrypted with a secret key known only to the AS and the TGS. This prevents alteration of the ticket. The ticket is reencrypted with a key based on the user's password. This assures that the ticket can be recovered only by the correct user, providing the authentication.

Now that the client has a ticket-granting ticket, access to any server can be obtained with steps 3 and 4.

3. The client requests a service-granting ticket on behalf of the user. For this purpose, the client transmits a message to the TGS containing the user's ID, the ID of the desired service, and the ticket-granting ticket.
4. The TGS decrypts the incoming ticket using a key shared only by the AS and the TGS (K_{tgs}) and verifies the success of the decryption by the presence of its ID. It checks to make sure that the lifetime has not expired. Then it compares the user ID and network address with the incoming information to authenticate the user. If the user is permitted access to the server V , the TGS issues a ticket to grant access to the requested service.

The service-granting ticket has the same structure as the ticket-granting ticket. Indeed, because the TGS is a server, we would expect that the same elements are needed to authenticate a client to the TGS and to authenticate a client to an application server. Again, the ticket contains a timestamp and lifetime. If the user wants access to the same service at a later time, the client can simply use the previously acquired service-granting ticket and need not bother the user for a password. Note that the ticket is encrypted with a secret key (K_v) known only to the TGS and the server, preventing alteration.

Finally, with a particular service-granting ticket, the client can gain access to the corresponding service with step 5.

5. The client requests access to a service on behalf of the user. For this purpose, the client transmits a message to the server containing the user's ID and the service-granting ticket. The server authenticates by using the contents of the ticket.

This new scenario satisfies the two requirements of only one password query per user session and protection of the user password.

THE VERSION 4 AUTHENTICATION DIALOGUE Although the foregoing scenario enhances security compared to the first attempt, two additional problems remain. The heart of the first problem is the lifetime associated with the ticket-granting ticket. If this lifetime is very short (e.g., minutes), then the user will be repeatedly asked for a password. If the lifetime is long (e.g., hours), then an opponent has a greater opportunity for replay. An opponent could eavesdrop on the network and capture a copy of the ticket-granting ticket and then wait for the legitimate user to log out. Then the opponent could forge the legitimate user's network address and send the message of step (3) to the TGS. This would give the opponent unlimited access to the resources and files available to the legitimate user.

Similarly, if an opponent captures a service-granting ticket and uses it before it expires, the opponent has access to the corresponding service.

Thus, we arrive at an additional requirement. A network service (the TGS or an application service) must be able to prove that the person using a ticket is the same person to whom that ticket was issued.

The second problem is that there may be a requirement for servers to authenticate themselves to users. Without such authentication, an opponent could sabotage the configuration so that messages to a server were directed to another location.

Table 16.2 Summary of Kerberos Version 4 Message Exchanges

<p>(1) $C \rightarrow AS$ $ID_c ID_{tgs} TS_1$</p> <p>(2) $AS \rightarrow C$ $E(K_c, [K_{c,tgs} ID_{tgs} TS_2 Lifetime_2 Ticket_{tgs}])$ $Ticket_{tgs} = E(K_{tgs}, [K_{c,tgs} ID_c AD_c ID_{tgs} TS_2 Lifetime_2])$</p>
(a) Authentication Service Exchange to obtain ticket-granting ticket
<p>(3) $C \rightarrow TGS$ $ID_v Ticket_{tgs} Authenticator_c$</p> <p>(4) $TGS \rightarrow C$ $E(K_{c,tgs}, [K_{c,v} ID_v TS_4 Ticket_v])$ $Ticket_{tgs} = E(K_{tgs}, [K_{c,tgs} ID_c AD_c ID_{tgs} TS_2 Lifetime_2])$ $Ticket_v = E(K_v, [K_{c,v} ID_c AD_c ID_v TS_4 Lifetime_4])$ $Authenticator_c = E(K_{c,tgs}, [ID_c AD_c TS_3])$</p>
(b) Ticket-Granting Service Exchange to obtain service-granting ticket
<p>(5) $C \rightarrow V$ $Ticket_v Authenticator_c$</p> <p>(6) $V \rightarrow C$ $E(K_{c,v}, [TS_5 + 1])$ (for mutual authentication) $Ticket_v = E(K_v, [K_{c,v} ID_c AD_c ID_v TS_4 Lifetime_4])$ $Authenticator_c = E(K_{c,v}, [ID_c AD_c TS_5])$</p>
(c) Client/Server Authentication Exchange to obtain service

The false server would then be in a position to act as a real server and capture any information from the user and deny the true service to the user.

We examine these problems in turn and refer to Table 16.2, which shows the actual Kerberos protocol. Figure 16.3 provides a simplified overview.

First, consider the problem of captured ticket-granting tickets and the need to determine that the ticket presenter is the same as the client for whom the ticket was issued. The threat is that an opponent will steal the ticket and use it before it expires. To get around this problem, let us have the AS provide both the client and the TGS with a secret piece of information in a secure manner. Then the client can prove its identity to the TGS by revealing the secret information—again in a secure manner. An efficient way of accomplishing this is to use an encryption key as the secure information; this is referred to as a session key in Kerberos.

Table 16.2a shows the technique for distributing the session key. As before, the client sends a message to the AS requesting access to the TGS. The AS responds with a message, encrypted with a key derived from the user's password (K_c), that contains the ticket. The encrypted message also contains a copy of the session key, $K_{c,tgs}$, where the subscripts indicate that this is a session key for C and TGS. Because this session key is inside the message encrypted with K_c , only the user's client can read it. The same session key is included in the ticket, which can be read only by the TGS. Thus, the session key has been securely delivered to both C and the TGS.

Note that several additional pieces of information have been added to this first phase of the dialogue. Message (1) includes a timestamp, so that the AS knows that the message is timely. Message (2) includes several elements of the ticket in a form accessible to C. This enables C to confirm that this ticket is for the TGS and to learn its expiration time.

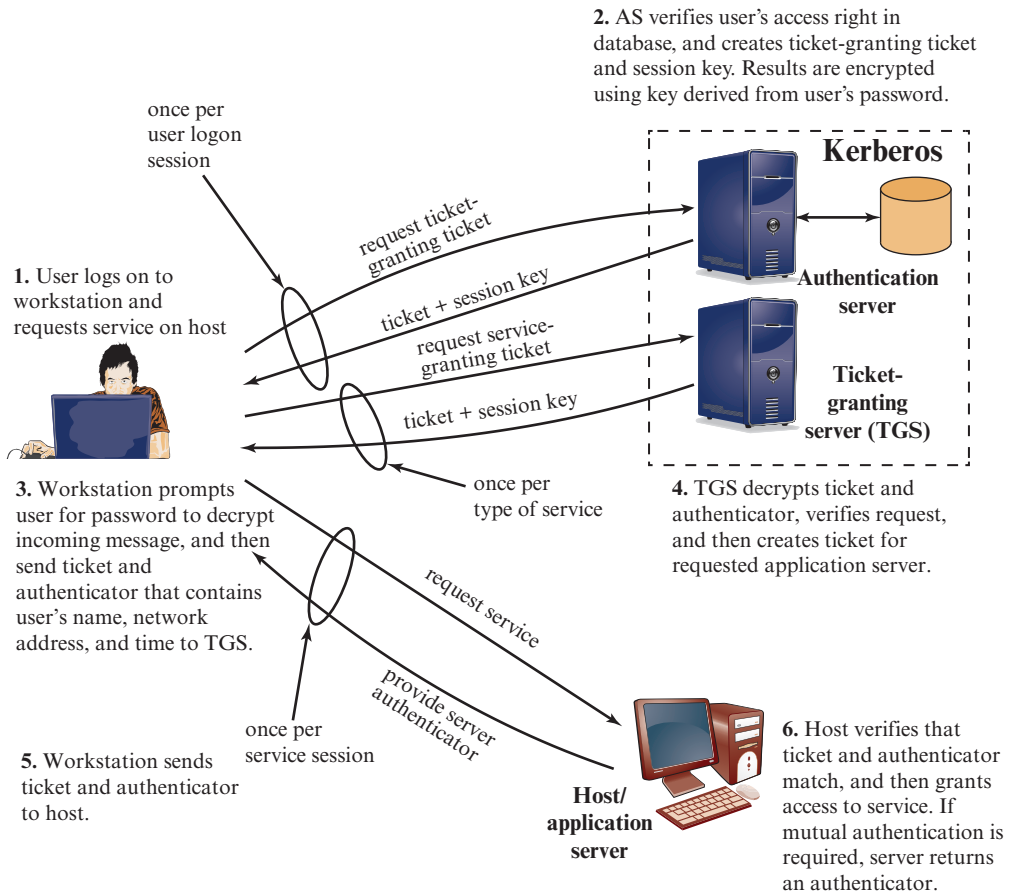

Figure 16.3 Overview of Kerberos

Armed with the ticket and the session key, C is ready to approach the TGS. As before, C sends the TGS a message that includes the ticket plus the ID of the requested service [message (3) in Table 16.2b]. In addition, C transmits an authenticator, which includes the ID and address of C 's user and a timestamp. Unlike the ticket, which is reusable, the authenticator is intended for use only once and has a very short lifetime. The TGS can decrypt the ticket with the key that it shares with the AS. This ticket indicates that user C has been provided with the session key $K_{c,tgs}$. In effect, the ticket says, "Anyone who uses $K_{c,tgs}$ must be C ." The TGS uses the session key to decrypt the authenticator. The TGS can then check the name and address from the authenticator with that of the ticket and with the network address of the incoming message. If all match, then the TGS is assured that the sender of the ticket is indeed the ticket's real owner. In effect, the authenticator says, "At time TS_3 , I hereby use $K_{c,tgs}$." Note that the ticket does not prove anyone's identity but is a way to distribute keys securely. It is the authenticator that proves the client's identity. Because the authenticator can be used only once and has a short lifetime, the threat

of an opponent stealing both the ticket and the authenticator for presentation later is countered.

The reply from the TGS in message (4) follows the form of message (2). The message is encrypted with the session key shared by the TGS and C and includes a session key to be shared between C and the server V, the ID of V, and the timestamp of the ticket. The ticket itself includes the same session key.

C now has a reusable service-granting ticket for V. When C presents this ticket, as shown in message (5), it also sends an authenticator. The server can decrypt the ticket, recover the session key, and decrypt the authenticator.

If mutual authentication is required, the server can reply as shown in message (6) of Table 16.2. The server returns the value of the timestamp from the authenticator, incremented by 1, and encrypted in the session key. C can decrypt this message to recover the incremented timestamp. Because the message was encrypted by the session key, C is assured that it could have been created only by V. The contents of the message assure C that this is not a replay of an old reply.

Finally, at the conclusion of this process, the client and server share a secret key. This key can be used to encrypt future messages between the two or to exchange a new random session key for that purpose.

Figure 16.4 illustrates the Kerberos exchanges among the parties.

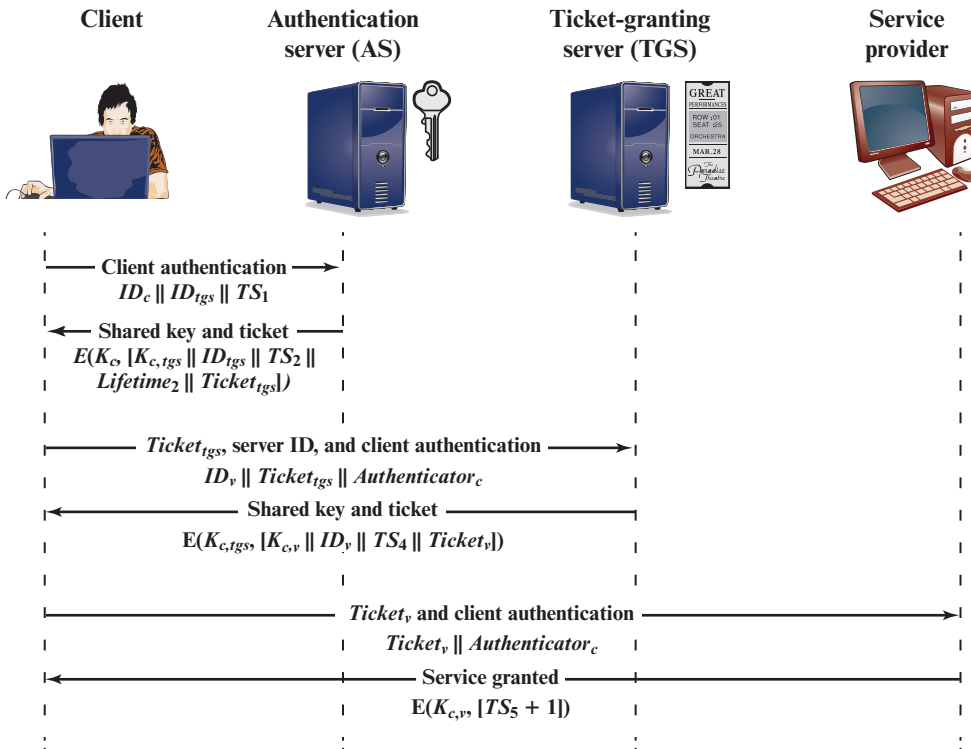

Figure 16.4 Kerberos Exchanges

KERBEROS REALMS AND MULTIPLE KERBERI A full-service Kerberos environment consisting of a Kerberos server, a number of clients, and a number of application servers requires the following:

1. The Kerberos server must have the user ID and hashed passwords of all participating users in its database. All users are registered with the Kerberos server.
2. The Kerberos server must share a secret key with each server. All servers are registered with the Kerberos server.

Such an environment is referred to as a Kerberos realm. The concept of realm can be explained as follows. A Kerberos realm is a set of managed nodes that share the same Kerberos database. The Kerberos database resides on the Kerberos master computer system, which should be kept in a physically secure room. A read-only copy of the Kerberos database might also reside on other Kerberos computer systems. However, all changes to the database must be made on the master computer system. Changing or accessing the contents of a Kerberos database requires the Kerberos master password. A related concept is that of a **Kerberos principal**, which is a service or user that is known to the Kerberos system. Each Kerberos principal is identified by its principal name. Principal names consist of three parts: a service or user name, an instance name, and a realm name.

Networks of clients and servers under different administrative organizations typically constitute different realms. That is, it generally is not practical or does not conform to administrative policy to have users and servers in one administrative domain registered with a Kerberos server elsewhere. However, users in one realm may need access to servers in other realms, and some servers may be willing to provide service to users from other realms, provided that those users are authenticated.

Kerberos provides a mechanism for supporting such interrealm authentication. For two realms to support interrealm authentication, a third requirement is added:

3. The Kerberos server in each interoperating realm shares a secret key with the server in the other realm. The two Kerberos servers are registered with each other.

The scheme requires that the Kerberos server in one realm trust the Kerberos server in the other realm to authenticate its users. Furthermore, the participating servers in the second realm must also be willing to trust the Kerberos server in the first realm.

With these ground rules in place, we can describe the mechanism as follows (Figure 16.5): A user wishing service on a server in another realm needs a ticket for that server. The user's client follows the usual procedures to gain access to the local TGS and then requests a ticket-granting ticket for a remote TGS (TGS in another realm). The client can then apply to the remote TGS for a service-granting ticket for the desired server in the realm of the remote TGS.

The details of the exchanges illustrated in Figure 16.5 are as follows (compare Table 16.2).

- (1) $C \rightarrow AS:$ $ID_c \parallel ID_{tgs} \parallel TS_1$
- (2) $AS \rightarrow C:$ $E(K_c, [K_{c, tgs} \parallel ID_{tgs} \parallel TS_2 \parallel Lifetime_2 \parallel Ticket_{tgs}])$
- (3) $C \rightarrow TGS:$ $ID_{tgsrem} \parallel Ticket_{tgs} \parallel Authenticator_c$

- (4) TGS → C: $E(K_{c,tgs}, [K_{c,tgsrem} \parallel ID_{tgsrem} \parallel TS_4 \parallel Ticket_{tgsrem}])$
- (5) C → TGS_{rem}: $ID_{vrem} \parallel Ticket_{tgsrem} \parallel Authenticator_c$
- (6) TGS_{rem} → C: $E(K_{c,tgsrem}, [K_{c,vrem} \parallel ID_{vrem} \parallel TS_6 \parallel Ticket_{vrem}])$
- (7) C → V_{rem}: $Ticket_{vrem} \parallel Authenticator_c$

The ticket presented to the remote server (V_{rem}) indicates the realm in which the user was originally authenticated. The server chooses whether to honor the remote request.

One problem presented by the foregoing approach is that it does not scale well to many realms. If there are N realms, then there must be $N(N - 1)/2$ secure key exchanges so that each Kerberos realm can interoperate with all other Kerberos realms.

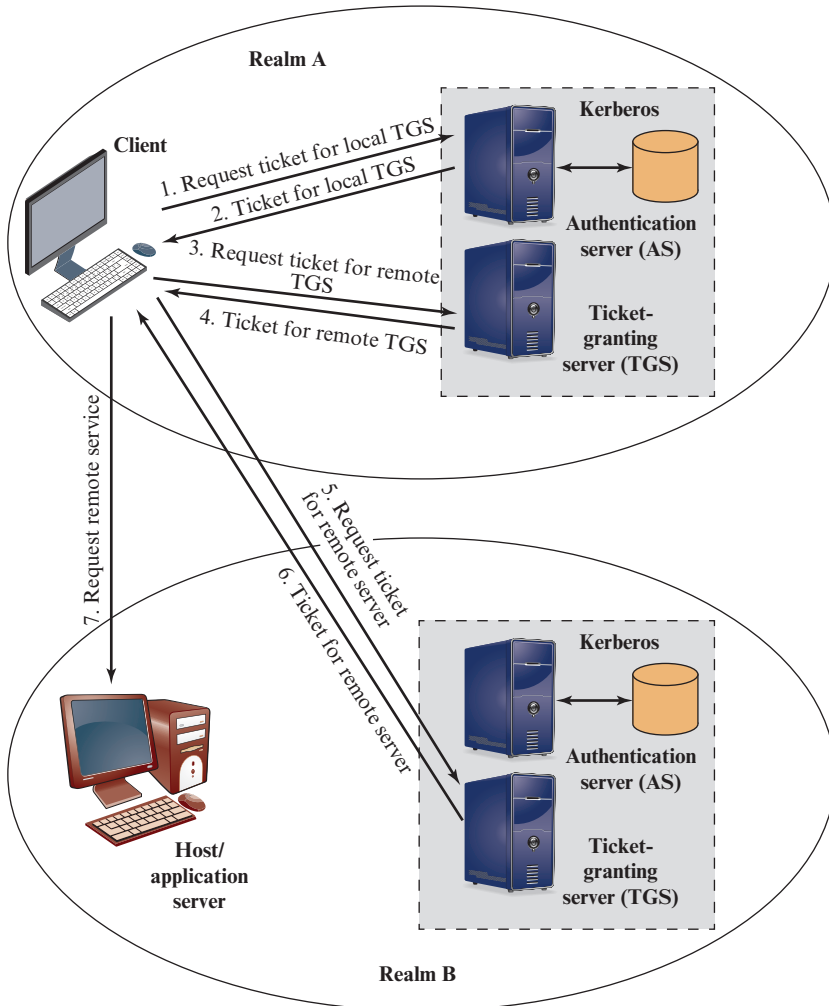

Figure 16.5 Request for Service in Another Realm

Kerberos Version 5

Kerberos version 5 is specified in RFC 4120 and provides a number of improvements over version 4 [KOHL94]. To begin, we provide an overview of the changes from version 4 to version 5 and then look at the version 5 protocol.

DIFFERENCES BETWEEN VERSIONS 4 AND 5 Version 5 is intended to address the limitations of version 4 in two areas: environmental shortcomings and technical deficiencies. Let us briefly summarize the improvements in each area.

Kerberos version 4 was developed for use within the Project Athena environment and, accordingly, did not fully address the need to be of general purpose. This led to the following **environmental shortcomings**.

1. **Encryption system dependence:** Version 4 requires the use of DES. Export restriction on DES as well as doubts about the strength of DES were thus of concern. Version 5 makes use of AES.
2. **Internet protocol dependence:** Version 4 requires the use of Internet Protocol (IP) addresses. Other address types, such as the ISO network address, are not accommodated. Version 5 network addresses are tagged with type and length, allowing any network address type to be used.
3. **Message byte ordering:** In version 4, the sender of a message employs a byte ordering of its own choosing and tags the message to indicate least significant byte in lowest address or most significant byte in lowest address. This technique works but does not follow established conventions. In version 5, all message structures are defined using Abstract Syntax Notation One (ASN.1) and Basic Encoding Rules (BER), which provide an unambiguous byte ordering.
4. **Ticket lifetime:** Lifetime values in version 4 are encoded in an 8-bit quantity in units of five minutes. Thus, the maximum lifetime that can be expressed is $2^8 \times 5 = 1280$ minutes (a little over 21 hours). This may be inadequate for some applications (e.g., a long-running simulation that requires valid Kerberos credentials throughout execution). In version 5, tickets include an explicit start time and end time, allowing tickets with arbitrary lifetimes.
5. **Authentication forwarding:** Version 4 does not allow credentials issued to one client to be forwarded to some other host and used by some other client. This capability would enable a client to access a server and have that server access another server on behalf of the client. For example, a client issues a request to a print server that then accesses the client's file from a file server, using the client's credentials for access. Version 5 provides this capability.
6. **Interrealm authentication:** In version 4, interoperability among N realms requires on the order of N^2 Kerberos-to-Kerberos relationships, as described earlier. Version 5 supports a method that requires fewer relationships, as described shortly.

Apart from these environmental limitations, there are **technical deficiencies** in the version 4 protocol itself. Most of these deficiencies were documented in [BELL90], and version 5 attempts to address these. The deficiencies are the following.

1. **Double encryption:** Note in Table 16.2 [messages (2) and (4)] that tickets provided to clients are encrypted twice—once with the secret key of the target server and then again with a secret key known to the client. The second encryption is not necessary and is computationally wasteful.
2. **PCBC encryption:** Encryption in version 4 makes use of a nonstandard mode of DES known as **propagating cipher block chaining (PCBC)**. It has been demonstrated that this mode is vulnerable to an attack involving the interchange of ciphertext blocks [KOHL89]. PCBC was intended to provide an integrity check as part of the encryption operation. Version 5 provides explicit integrity mechanisms, allowing the standard CBC mode to be used for encryption. In particular, a checksum or hash code is attached to the message prior to encryption using CBC.
3. **Session keys:** Each ticket includes a session key that is used by the client to encrypt the authenticator sent to the service associated with that ticket. In addition, the session key may subsequently be used by the client and the server to protect messages passed during that session. However, because the same ticket may be used repeatedly to gain service from a particular server, there is the risk that an opponent will replay messages from an old session to the client or the server. In version 5, it is possible for a client and server to negotiate a subsession key, which is to be used only for that one connection. A new access by the client would result in the use of a new subsession key.
4. **Password attacks:** Both versions are vulnerable to a password attack. The message from the AS to the client includes material encrypted with a key based on the client's password. An opponent can capture this message and attempt to decrypt it by trying various passwords. If the result of a test decryption is of the proper form, then the opponent has discovered the client's password and may subsequently use it to gain authentication credentials from Kerberos. Version 5 does provide a mechanism known as preauthentication, which should make password attacks more difficult, but it does not prevent them.

THE VERSION 5 AUTHENTICATION DIALOGUE Table 16.3 summarizes the basic version 5 dialogue. This is best explained by comparison with version 4 (Table 16.2).

First, consider the **authentication service exchange**. Message (1) is a client request for a ticket-granting ticket. As before, it includes the ID of the user and the TGS. The following new elements are added:

- **Realm:** Indicates realm of user
- **Options:** Used to request that certain flags be set in the returned ticket
- **Times:** Used by the client to request the following time settings in the ticket:
 - **from:** the desired start time for the requested ticket
 - **till:** the requested expiration time for the requested ticket
 - **rtime:** requested renew-till time
- **Nonce:** A random value to be repeated in message (2) to assure that the response is fresh and has not been replayed by an opponent

Message (2) returns a ticket-granting ticket, identifying information for the client, and a block encrypted using the encryption key based on the user's password.

Table 16.3 Summary of Kerberos Version 5 Message Exchanges

(1)	$C \rightarrow AS$	$Options \parallel ID_C \parallel Realm_c \parallel ID_{TGS} \parallel Times \parallel Nonce_1$
(2)	$AS \rightarrow C$	$Realm_c \parallel ID_C \parallel Ticket_{TGS} \parallel E(K_{c,TGS}, [K_{c,TGS} \parallel Times \parallel Nonce_1 \parallel Realm_{TGS} \parallel ID_{TGS}])$ $Ticket_{TGS} = E(K_{TGS}, [Flags \parallel K_{c,TGS} \parallel Realm_c \parallel ID_C \parallel AD_C \parallel Times])$
(a) Authentication Service Exchange to obtain ticket-granting ticket		
(3)	$C \rightarrow TGS$	$Options \parallel ID_v \parallel Times \parallel Nonce_2 \parallel Ticket_{TGS} \parallel Authenticator_c$
(4)	$TGS \rightarrow C$	$Realm_c \parallel ID_C \parallel Ticket_v \parallel E(K_{c,TGS}, [K_{c,v} \parallel Times \parallel Nonce_2 \parallel Realm_v \parallel ID_v])$ $Ticket_{TGS} = E(K_{TGS}, [Flags \parallel K_{c,TGS} \parallel Realm_c \parallel ID_C \parallel AD_C \parallel Times])$ $Ticket_v = E(K_v, [Flags \parallel K_{c,v} \parallel Realm_c \parallel ID_C \parallel AD_C \parallel Times])$ $Authenticator_c = E(K_{c,TGS}, [ID_C \parallel Realm_c \parallel TS_1])$
(b) Ticket-Granting Service Exchange to obtain service-granting ticket		
(5)	$C \rightarrow V$	$Options \parallel Ticket_v \parallel Authenticator_c$
(6)	$V \rightarrow C$	$E_{K_{c,v}}[TS_2 \parallel Subkey \parallel Seq \#]$ $Ticket_v = E(K_v, [Flag \parallel K_{c,v} \parallel Realm_c \parallel ID_C \parallel AD_C \parallel Times])$ $Authenticator_c = E(K_{c,v}, [ID_C \parallel Relam_c \parallel TS_2 \parallel Subkey \parallel Seq \#])$
(c) Client/Server Authentication Exchange to obtain service		

This block includes the session key to be used between the client and the TGS, times specified in message (1), the nonce from message (1), and TGS identifying information. The ticket itself includes the session key, identifying information for the client, the requested time values, and flags that reflect the status of this ticket and the requested options.

Let us now compare the **ticket-granting service exchange** for versions 4 and 5. We see that message (3) for both versions includes an authenticator, a ticket, and the name of the requested service. In addition, version 5 includes requested times and options for the ticket and a nonce—all with functions similar to those of message (1). The authenticator itself is essentially the same as the one used in version 4.

Message (4) has the same structure as message (2). It returns a ticket plus information needed by the client, with the information encrypted using the session key now shared by the client and the TGS.

Finally, for the **client/server authentication exchange**, several new features appear in version 5. In message (5), the client may request as an option that mutual authentication is required. The authenticator includes several new fields:

- **Subkey:** The client's choice for an encryption key to be used to protect this specific application session. If this field is omitted, the session key from the ticket ($K_{c,v}$) is used.
- **Sequence number:** An optional field that specifies the starting sequence number to be used by the server for messages sent to the client during this session. Messages may be sequence numbered to detect replays.

If mutual authentication is required, the server responds with message (6). This message includes the timestamp from the authenticator. Note that in version 4, the timestamp was incremented by one. This is not necessary in version 5, because

the nature of the format of messages is such that it is not possible for an opponent to create message (6) without knowledge of the appropriate encryption keys. The subkey field, if present, overrides the subkey field, if present, in message (5). The optional sequence number field specifies the starting sequence number to be used by the client.

16.4 REMOTE USER-AUTHENTICATION USING ASYMMETRIC ENCRYPTION

Mutual Authentication

In Chapter 15, we presented one approach to the use of public-key encryption for the purpose of session-key distribution (Figure 15.5). This protocol assumes that each of the two parties is in possession of the current public key of the other. It may not be practical to require this assumption.

A protocol using timestamps is provided in [DENN81]:

1. $A \rightarrow AS: ID_A \parallel ID_B$
2. $AS \rightarrow A: E(PR_{as}, [ID_A \parallel PU_a \parallel T]) \parallel E(PR_{as}, [ID_B \parallel PU_b \parallel T])$
3. $A \rightarrow B: E(PR_{as}, [ID_A \parallel PU_a \parallel T]) \parallel E(PR_{as}, [ID_B \parallel PU_b \parallel T]) \parallel E(PU_b, E(PR_a, [K_s \parallel T]))$

In this case, the central system is referred to as an authentication server (AS), because it is not actually responsible for secret-key distribution. Rather, the AS provides public-key certificates. The session key is chosen and encrypted by A; hence, there is no risk of exposure by the AS. The timestamps protect against replays of compromised keys.

This protocol is compact but, as before, requires the synchronization of clocks. Another approach, proposed by Woo and Lam [WOO92a], makes use of nonces. The protocol consists of the following steps.

1. $A \rightarrow KDC: ID_A \parallel ID_B$
2. $KDC \rightarrow A: E(PR_{auth}, [ID_B \parallel PU_b])$
3. $A \rightarrow B: E(PU_b, [N_a \parallel ID_A])$
4. $B \rightarrow KDC: ID_A \parallel ID_B \parallel E(PU_{auth}, N_a)$
5. $KDC \rightarrow B: E(PR_{auth}, [ID_A \parallel PU_a]) \parallel E(PU_b, E(PR_{auth}, [N_a \parallel K_s \parallel ID_B]))$
6. $B \rightarrow A: E(PU_a, [E(PR_{auth}, [(N_a \parallel K_s \parallel ID_B))] \parallel N_b])$
7. $A \rightarrow B: E(K_s, N_b)$

In step 1, A informs the KDC of its intention to establish a secure connection with B. The KDC returns to A a copy of B's public-key certificate (step 2). Using B's public key, A informs B of its desire to communicate and sends a nonce N_a (step 3). In step 4, B asks the KDC for A's public-key certificate and requests a session key; B includes A's nonce so that the KDC can stamp the session key with that nonce. The nonce is protected using the KDC's public key. In step 5, the KDC returns to B a copy of A's public-key certificate, plus the information $\{N_a, K_s, ID_B\}$. This

information basically says that K_s is a secret key generated by the KDC on behalf of B and tied to N_a ; the binding of K_s and N_a will assure A that K_s is fresh. This triple is encrypted using the KDC's private key to allow B to verify that the triple is in fact from the KDC. It is also encrypted using B's public key so that no other entity may use the triple in an attempt to establish a fraudulent connection with A. In step 6, the triple $\{N_a, K_s, ID_B\}$, still encrypted with the KDC's private key, is relayed to A, together with a nonce N_b generated by B. All the foregoing are encrypted using A's public key. A retrieves the session key K_s , uses it to encrypt N_b , and returns it to B. This last message assures B of A's knowledge of the session key.

This seems to be a secure protocol that takes into account the various attacks. However, the authors themselves spotted a flaw and submitted a revised version of the algorithm in [WOO92b]:

1. A \rightarrow KDC: $ID_A \parallel ID_B$
2. KDC \rightarrow A: $E(PR_{auth}, [ID_B \parallel PU_b])$
3. A \rightarrow B: $E(PU_b, [N_a \parallel ID_A])$
4. B \rightarrow KDC: $ID_A \parallel ID_B \parallel E(PU_{auth}, N_a)$
5. KDC \rightarrow B: $E(PR_{auth}, [ID_A \parallel PU_a]) \parallel E(PU_b, E(PR_{auth}, [N_a \parallel K_s \parallel ID_A \parallel ID_B]))$
6. B \rightarrow A: $E(PU_a, [N_b \parallel E(PR_{auth}, [N_a \parallel K_s \parallel ID_A \parallel ID_B])])$
7. A \rightarrow B: $E(K_s, N_b)$

The identifier of A, ID_A , is added to the set of items encrypted with the KDC's private key in steps 5 and 6. This binds the session key K_s to the identities of the two parties that will be engaged in the session. This inclusion of ID_A accounts for the fact that the nonce value N_a is considered unique only among all nonces generated by A, not among all nonces generated by all parties. Thus, it is the pair $\{ID_A, N_a\}$ that uniquely identifies the connection request of A.

In both this example and the protocols described earlier, protocols that appeared secure were revised after additional analysis. These examples highlight the difficulty of getting things right in the area of authentication.

One-Way Authentication

One-way authentication involves a single transfer of information from one user (A) intended for another (B). In its simplest form, one way authentication would establish the identity of A, the identity of B, and establish that some sort of authentication token actually was generated by A and actually was intended to be sent to B. An email message is an example of an application that lends itself to one-way authentication. We have already presented public-key encryption approaches that are suited to electronic mail, including the straightforward encryption of the entire message for confidentiality (Figure 12.1b), authentication (Figure 12.1c), or both (Figure 12.1d). These approaches require that either the sender know the recipient's public key (confidentiality), the recipient know the sender's public key (authentication), or both (confidentiality plus authentication). In addition, the public-key algorithm must be applied once or twice to what may be a long message.

If confidentiality is the primary concern, then the following may be more efficient:

$$A \rightarrow B: E(PU_b, K_s) \parallel E(K_s, M)$$

In this case, the message is encrypted with a one-time secret key. A also encrypts this one-time key with B's public key. Only B will be able to use the corresponding private key to recover the one-time key and then use that key to decrypt the message. This scheme is more efficient than simply encrypting the entire message with B's public key.

If authentication is the primary concern, then a digital signature may suffice, as was illustrated in Figure 13.1:

$$A \rightarrow B: M \parallel E(PR_a, H(M))$$

This method guarantees that A cannot later deny having sent the message. However, this technique is open to another kind of fraud. Bob composes a message to his boss Alice that contains an idea that will save the company money. He appends his digital signature and sends it into the email system. Eventually, the message will get delivered to Alice's mailbox. But suppose that Max has heard of Bob's idea and gains access to the mail queue before delivery. He finds Bob's message, strips off his signature, appends his, and requeues the message to be delivered to Alice. Max gets credit for Bob's idea.

To counter such a scheme, both the message and signature can be encrypted with the recipient's public key:

$$A \rightarrow B: E(PU_b, [M \parallel E(PR_a, H(M))])$$

The latter two schemes require that B know A's public key and be convinced that it is timely. An effective way to provide this assurance is the digital certificate, described in Chapter 14. Now we have

$$A \rightarrow B: M \parallel E(PR_a, H(M)) \parallel E(PR_{as}, [T \parallel ID_A \parallel PU_a])$$

In addition to the message, A sends B the signature encrypted with A's private key and A's certificate encrypted with the private key of the authentication server. The recipient of the message first uses the certificate to obtain the sender's public key and verify that it is authentic and then uses the public key to verify the message itself. If confidentiality is required, then the entire message can be encrypted with B's public key. Alternatively, the entire message can be encrypted with a one-time secret key; the secret key is also transmitted, encrypted with B's public key. This approach is explored in Chapter 21.

16.5 FEDERATED IDENTITY MANAGEMENT

Federated identity management is a relatively new concept dealing with the use of a common identity management scheme across multiple enterprises and numerous applications and supporting many thousands, even millions, of users. We begin our overview with a discussion of the concept of identity management and then examine federated identity management.

Identity Management

Identity management is a centralized, automated approach to provide enterprise-wide access to resources by employees and other authorized individuals. The focus of identity management is defining an identity for each user (human or process),

associating attributes with the identity, and enforcing a means by which a user can verify identity. The central concept of an identity management system is the use of single sign-on (SSO).

SSO enables a user to access all network resources after a single authentication.

Typical services provided by a federated identity management system include the following:

- **Point of contact:** Includes authentication that a user corresponds to the user name provided, and management of user/server sessions.
- **SSO protocol services:** Provides a vendor-neutral security token service for supporting a single sign on to federated services.
- **Trust services:** Federation relationships require a trust relationship-based federation between business partners. A trust relationship is represented by the combination of the security tokens used to exchange information about a user, the cryptographic information used to protect these security tokens, and optionally the identity mapping rules applied to the information contained within this token.
- **Key services:** Management of keys and certificates.
- **Identity services:** Services that provide the interface to local data stores, including user registries and databases, for identity-related information management.
- **Authorization:** Granting access to specific services and/or resources based on the authentication.
- **Provisioning:** Includes creating an account in each target system for the user, enrollment or registration of user in accounts, establishment of access rights or credentials to ensure the privacy and integrity of account data.
- **Management:** Services related to runtime configuration and deployment.

Note that Kerberos contains a number of the elements of an identity management system.

Figure 16.6 illustrates entities and data flows in a generic identity management architecture. A **principal** is an identity holder. Typically, this is a human user that seeks access to resources and services on the network. User devices, agent processes, and server systems may also function as principals. Principals authenticate themselves to an **identity provider**. The identity provider associates authentication information with a principal, as well as attributes and one or more identifiers.

Increasingly, digital identities incorporate attributes other than simply an identifier and authentication information (such as passwords and biometric information). An **attribute service** manages the creation and maintenance of such attributes. For example, a user needs to provide a shipping address each time an order is placed at a new Web merchant, and this information needs to be revised when the user moves. Identity management enables the user to provide this information once, so that it is maintained in a single place and released to data consumers in accordance with authorization and privacy policies. Users may create some of the attributes to be associated with their digital identity, such as an address. **Administrators** may also assign attributes to users, such as roles, access permissions, and employee information.

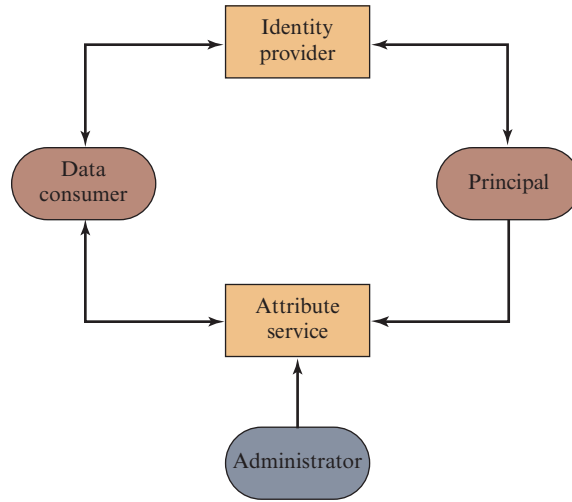

Figure 16.6 Generic Identity Management Architecture

Data consumers are entities that obtain and employ data maintained and provided by identity and attribute providers, which are often used to support authorization decisions and to collect audit information. For example, a database server or file server is a data consumer that needs a client’s credentials so as to know what access to provide to that client.

Identity Federation

Identity federation is, in essence, an extension of identity management to multiple security domains. Such domains include autonomous internal business units, external business partners, and other third-party applications and services. The goal is to provide the sharing of digital identities so that a user can be authenticated a single time and then access applications and resources across multiple domains. Because these domains are relatively autonomous or independent, no centralized control is possible. Rather, the cooperating organizations must form a federation based on agreed standards and mutual levels of trust to securely share digital identities.

Federated identity management refers to the agreements, standards, and technologies that enable the portability of identities, identity attributes, and entitlements across multiple enterprises and numerous applications and supporting many thousands, even millions, of users. When multiple organizations implement interoperable federated identity schemes, an employee in one organization can use a single sign-on to access services across the federation with trust relationships associated with the identity. For example, an employee may log onto her corporate intranet and be authenticated to perform authorized functions and access authorized services on that intranet. The employee could then access their health benefits from an outside health-care provider without having to reauthenticate.

Beyond SSO, federated identity management provides other capabilities. One is a standardized means of representing attributes. Increasingly, digital identities

incorporate attributes other than simply an identifier and authentication information (such as passwords and biometric information). Examples of attributes include account numbers, organizational roles, physical location, and file ownership. A user may have multiple identifiers; for example, each identifier may be associated with a unique role with its own access permissions.

Another key function of federated identity management is identity mapping. Different security domains may represent identities and attributes differently. Further, the amount of information associated with an individual in one domain may be more than is necessary in another domain. The federated identity management protocols map identities and attributes of a user in one domain to the requirements of another domain.

Figure 16.7 illustrates entities and data flows in a generic federated identity management architecture.

The identity provider acquires attribute information through dialogue and protocol exchanges with users and administrators. For example, a user needs to provide a shipping address each time an order is placed at a new Web merchant, and this

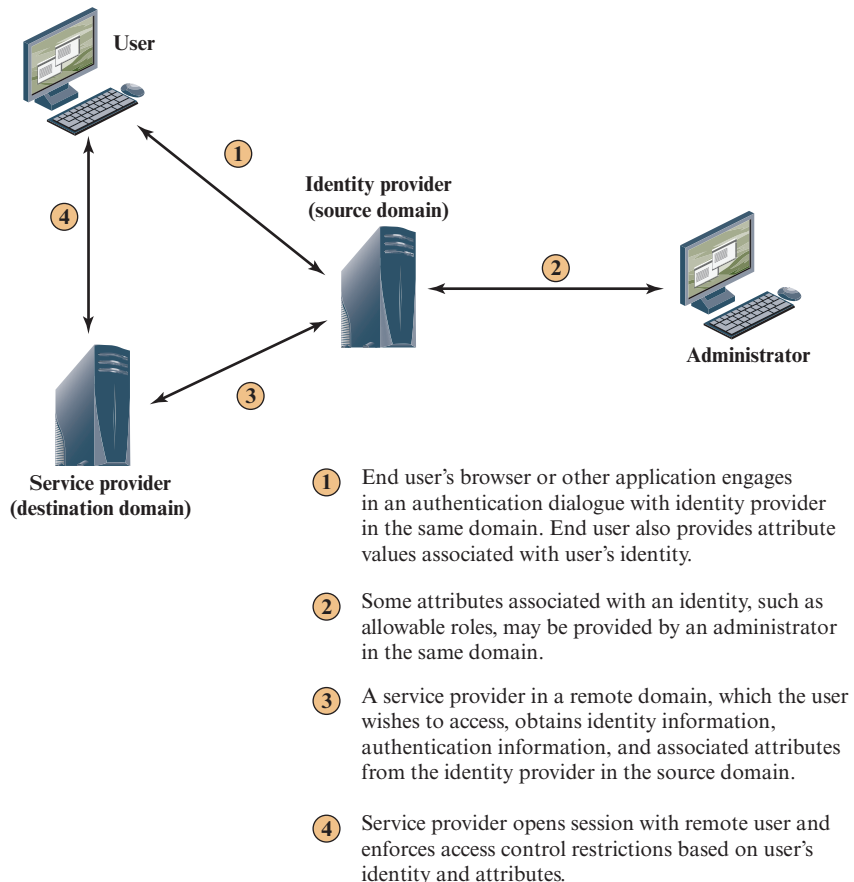

Figure 16.7 Federated Identity Operation

information needs to be revised when the user moves. Identity management enables the user to provide this information once, so that it is maintained in a single place and released to data consumers in accordance with authorization and privacy policies.

Service providers are entities that obtain and employ data maintained and provided by identity providers, often to support authorization decisions and to collect audit information. For example, a database server or file server is a data consumer that needs a client's credentials so as to know what access to provide to that client. A service provider can be in the same domain as the user and the identity provider. The power of this approach is for federated identity management, in which the service provider is in a different domain (e.g., a vendor or supplier network).

16.6 KEY TERMS, REVIEW QUESTIONS, AND PROBLEMS

Key Terms

authentication authentication server	federated identity management Kerberos	nonce replay attack timestamp
---	--	-------------------------------------

Review Questions

- 16.1 Give examples of replay attacks.
- 16.2 List three general approaches to dealing with replay attacks.
- 16.3 What is a suppress-replay attack?
- 16.4 What problem was Kerberos designed to address?
- 16.5 In Kerberos, what is the purpose of the centralized authentication server?
- 16.6 Which approach to secure user authentication in a distributed environment does Kerberos support?
- 16.7 What four requirements were defined for Kerberos?
- 16.8 What entities constitute a full-service Kerberos environment?
- 16.9 In the context of Kerberos, explain the concept of realm.
- 16.10 What are the principal differences between version 4 and version 5 of Kerberos?

Problems

- 16.1 In Section 16.4, we outlined the public-key scheme proposed in [WOO92a] for the distribution of secret keys. The revised version includes ID_A in steps 5 and 6. What attack, specifically, is countered by this revision?
- 16.2 The protocol referred to in Problem 16.1 can be reduced from seven steps to five, having the following sequence:
 - a. $A \rightarrow B$:
 - b. $A \rightarrow KDC$:
 - c. $KDC \rightarrow B$:
 - d. $B \rightarrow A$:
 - e. $A \rightarrow B$:

Show the message transmitted at each step. *Hint:* The final message in this protocol is the same as the final message in the original protocol.

- 16.3** Explain why replacing the timestamp by a nonce in the protocol proposed by Denning, and described in Section 16.2, does not offer protection against suppress-replay attacks.
- 16.4** There are three typical ways to use nonces as challenges. Suppose N_a is a nonce generated by A, A and B share key K, and $f()$ is a function (such as an increment). The three usages are

Usage 1	Usage 2	Usage 3
(1) $A \rightarrow B: N_a$	(1) $A \rightarrow B: E(K, N_a)$	(1) $A \rightarrow B: E(K, N_a)$
(2) $B \rightarrow A: E(K, N_a)$	(2) $B \rightarrow A: N_a$	(2) $B \rightarrow A: E(K, f(N_a))$

Describe situations for which each usage is appropriate.

- 16.5** In addition to providing a standard for public-key certificate formats, X.509 specifies an authentication protocol. The original version of X.509 contains a security flaw. The essence of the protocol is as follows.

$$\begin{aligned}
 A \rightarrow B: & \quad A \{t_A, r_A, ID_B\} \\
 B \rightarrow A: & \quad B \{t_B, r_B, ID_A, r_A\} \\
 A \rightarrow B: & \quad A \{r_B\}
 \end{aligned}$$

where t_A and t_B are timestamps, r_A and r_B are nonces and the notation $X\{Y\}$ indicates that the message Y is transmitted, encrypted, and signed by X.

The text of X.509 states that checking timestamps t_A and t_B is optional for three-way authentication. But consider the following example: Suppose A and B have used the preceding protocol on some previous occasion, and that opponent C has intercepted the preceding three messages. In addition, suppose that timestamps are not used and are all set to 0. Finally, suppose C wishes to impersonate A to B. C initially sends the first captured message to B:

$$C \rightarrow B: \quad A \{0, r_A, ID_B\}$$

B responds, thinking it is talking to A but is actually talking to C:

$$B \rightarrow C: \quad B \{0, r'_B, ID_A, r_A\}$$

C meanwhile causes A to initiate authentication with C by some means. As a result, A sends C the following:

$$A \rightarrow C: \quad A \{0, r'_A, ID_C\}$$

C responds to A using the same nonce provided to C by B:

$$C \rightarrow A: \quad C \{0, r'_B, ID_A, r'_A\}$$

A responds with

$$A \rightarrow C: \quad A \{r'_B\}$$

This is exactly what C needs to convince B that it is talking to A, so C now repeats the incoming message back out to B.

$$C \rightarrow B: A \{r'_B\}$$

So B will believe it is talking to A whereas it is actually talking to C. Suggest a simple solution to this problem that does not involve the use of timestamps.

- 16.6** Consider a one-way authentication technique based on asymmetric encryption:

$$A \rightarrow B: ID_A$$

$$B \rightarrow A: R_1$$

$$A \rightarrow B: E(PR_a, R_1)$$

- a. Explain the protocol.
- b. What type of attack is this protocol susceptible to?

- 16.7** Consider a one-way authentication technique based on asymmetric encryption:

$$A \rightarrow B: ID_A \| E(PU_B, R_A)$$

$$B \rightarrow A: R_A$$

- a. Explain the protocol.
- b. What type of attack is this protocol susceptible to?

- 16.8** In Kerberos, when Bob receives a ticket from Alice, how does he know it is not genuine?

- 16.9** In Kerberos, how does Bob know that the received token is not corresponding to Alice's?

- 16.10** In Kerberos, how does Alice know that a reply to an earlier message is from Bob?

- 16.11** In Kerberos, where do Alice and Bob find the session key that they need to secure their communication?

TRANSPORT-LEVEL SECURITY

17.1 Web Security Considerations

- Web Security Threats
- Web Traffic Security Approaches

17.2 Transport Layer Security

- TLS Architecture
- TLS Record Protocol
- Change Cipher Spec Protocol
- Alert Protocol
- Handshake Protocol
- Cryptographic Computations
- SSL/TLS Attacks
- TLSv1.3

17.3 HTTPS

- Connection Initiation
- Connection Closure

17.4 Secure Shell (SSH)

- Transport Layer Protocol
- User Authentication Protocol
- Connection Protocol

17.5 Review Questions and Problems

LEARNING OBJECTIVES

After studying this chapter, you should be able to:

- ◆ Summarize Web security threats and Web traffic security approaches.
- ◆ Present an overview of Transport Layer Security (TLS).
- ◆ Understand the differences between Secure Sockets Layer and Transport Layer Security.
- ◆ Compare the pseudorandom function used in Transport Layer Security with those discussed earlier in the book.
- ◆ Present an overview of HTTPS (HTTP over SSL).
- ◆ Present an overview of Secure Shell (SSH).

Virtually all businesses, most government agencies, and many individuals now have Web sites. The number of individuals and companies with Internet access is expanding rapidly and all of these have graphical Web browsers. As a result, businesses are enthusiastic about setting up facilities on the Web for electronic commerce. But the reality is that the Internet and the Web are extremely vulnerable to compromises of various sorts. As businesses wake up to this reality, the demand for secure Web services grows.

The topic of Web security is a broad one and can easily fill a book. In this chapter, we begin with a discussion of the general requirements for Web security and then focus on three standardized schemes that are becoming increasingly important as part of Web commerce and that focus on security at the transport layer: SSL/TLS, HTTPS, and SSH.

17.1 WEB SECURITY CONSIDERATIONS

The World Wide Web is fundamentally a client/server application running over the Internet and TCP/IP intranets. As such, the security tools and approaches discussed so far in this book are relevant to the issue of Web security. However, the following characteristics of Web usage suggest the need for tailored security tools:

- Although Web browsers are very easy to use, Web servers are relatively easy to configure and manage, and Web content is increasingly easy to develop, the underlying software is extraordinarily complex. This complex software may hide many potential security flaws. The short history of the Web is filled with examples of new and upgraded systems, properly installed, that are vulnerable to a variety of security attacks.
- A Web server can be exploited as a launching pad into the corporation's or agency's entire computer complex. Once the Web server is subverted, an attacker may be able to gain access to data and systems not part of the Web itself but connected to the server at the local site.

- Casual and untrained (in security matters) users are common clients for Web-based services. Such users are not necessarily aware of the security risks that exist and do not have the tools or knowledge to take effective countermeasures.

Web Security Threats

Table 17.1 provides a summary of the types of security threats faced when using the Web. One way to group these threats is in terms of passive and active attacks. Passive attacks include eavesdropping on network traffic between browser and server and gaining access to information on a Web site that is supposed to be restricted. Active attacks include impersonating another user, altering messages in transit between client and server, and altering information on a Web site.

Another way to classify Web security threats is in terms of the location of the threat: Web server, Web browser, and network traffic between browser and server. Issues of server and browser security fall into the category of computer system security; Part Six of this book addresses the issue of system security in general but is also applicable to Web system security. Issues of traffic security fall into the category of network security and are addressed in this chapter.

Web Traffic Security Approaches

A number of approaches to providing Web security are possible. The various approaches that have been considered are similar in the services they provide and, to some extent, in the mechanisms that they use, but they differ with respect to their scope of applicability and their relative location within the TCP/IP protocol stack.

Table 17.1 A Comparison of Threats on the Web

	Threats	Consequences	Countermeasures
Integrity	<ul style="list-style-type: none"> • Modification of user data • Trojan horse browser • Modification of memory • Modification of message traffic in transit 	<ul style="list-style-type: none"> • Loss of information • Compromise of machine • Vulnerability to all other threats 	Cryptographic checksums
Confidentiality	<ul style="list-style-type: none"> • Eavesdropping on the net • Theft of info from server • Theft of data from client • Info about network configuration • Info about which client talks to server 	<ul style="list-style-type: none"> • Loss of information • Loss of privacy 	Encryption, Web proxies
Denial of Service	<ul style="list-style-type: none"> • Killing of user threads • Flooding machine with bogus requests • Filling up disk or memory • Isolating machine by DNS attacks 	<ul style="list-style-type: none"> • Disruptive • Annoying • Prevent user from getting work done 	Difficult to prevent
Authentication	<ul style="list-style-type: none"> • Impersonation of legitimate users • Data forgery 	<ul style="list-style-type: none"> • Misrepresentation of user • Belief that false information is valid 	Cryptographic techniques

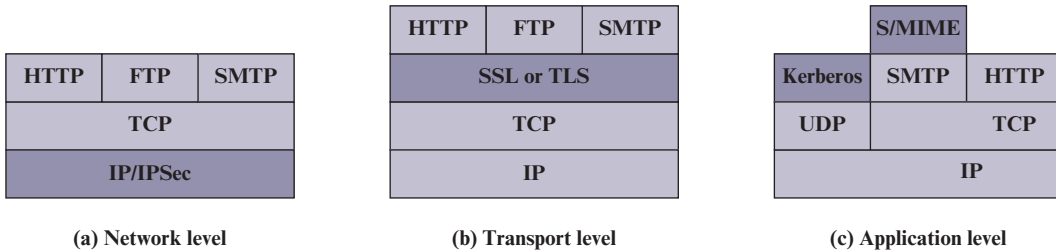

Figure 17.1 Relative Location of Security Facilities in the TCP/IP Protocol Stack

Figure 17.1 illustrates this difference. One way to provide Web security is to use IP security (IPsec) (Figure 17.1a). The advantage of using IPsec is that it is transparent to end users and applications and provides a general-purpose solution. Furthermore, IPsec includes a filtering capability so that only selected traffic need incur the overhead of IPsec processing.

Another relatively general-purpose solution is to implement security just above TCP (Figure 17.1b). The foremost example of this approach is the Secure Sockets Layer (SSL) and the follow-on Internet standard known as Transport Layer Security (TLS). At this level, there are two implementation choices. For full generality, SSL (or TLS) could be provided as part of the underlying protocol suite and therefore be transparent to applications. Alternatively, TLS can be embedded in specific packages. For example, virtually all browsers come equipped with TLS, and most Web servers have implemented the protocol.

Application-specific security services are embedded within the particular application. Figure 17.1c shows examples of this architecture. The advantage of this approach is that the service can be tailored to the specific needs of a given application.

17.2 TRANSPORT LAYER SECURITY

One of the most widely used security services is Transport Layer Security (TSL); the current version is Version 1.2, defined in RFC 5246. TLS is an Internet standard that evolved from a commercial protocol known as **Secure Sockets Layer (SSL)**. Although SSL implementations are still around, it has been deprecated by IETF and is disabled by most corporations offering TLS software. TLS is a general-purpose service implemented as a set of protocols that rely on TCP. At this level, there are two implementation choices. For full generality, TLS could be provided as part of the underlying protocol suite and therefore be transparent to applications. Alternatively, TLS can be embedded in specific packages. For example, most browsers come equipped with TLS, and most Web servers have implemented the protocol.

TLS Architecture

TLS is designed to make use of TCP to provide a reliable end-to-end secure service. TLS is not a single protocol but rather two layers of protocols, as illustrated in Figure 17.2.

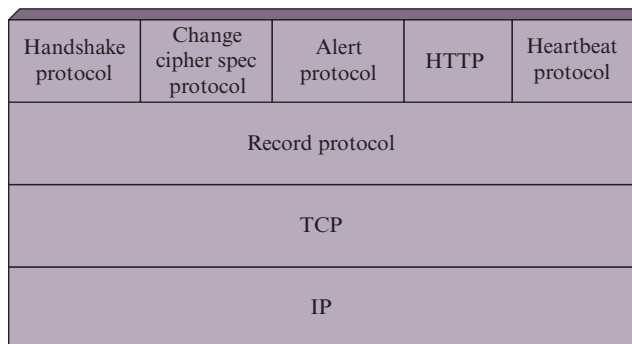

Figure 17.2 TLS Protocol Stack

The TLS Record Protocol provides basic security services to various higher-layer protocols. In particular, the **Hypertext Transfer Protocol (HTTP)**, which provides the transfer service for Web client/server interaction, can operate on top of TLS. Three higher-layer protocols are defined as part of TLS: the Handshake Protocol; the Change Cipher Spec Protocol; and the Alert Protocol. These TLS-specific protocols are used in the management of TLS exchanges and are examined later in this section. A fourth protocol, the Heartbeat Protocol, is defined in a separate RFC and is also discussed subsequently in this section.

Two important TLS concepts are the TLS session and the TLS connection, which are defined in the specification as follows:

- **Connection:** A connection is a transport (in the OSI layering model definition) that provides a suitable type of service. For TLS, such connections are peer-to-peer relationships. The connections are transient. Every connection is associated with one session.
- **Session:** A TLS session is an association between a client and a server. Sessions are created by the Handshake Protocol. Sessions define a set of cryptographic security parameters, which can be shared among multiple connections. Sessions are used to avoid the expensive negotiation of new security parameters for each connection.

Between any pair of parties (applications such as HTTP on client and server), there may be multiple secure connections. In theory, there may also be multiple simultaneous sessions between parties, but this feature is not used in practice.

There are a number of states associated with each session. Once a session is established, there is a current operating state for both read and write (i.e., receive and send). In addition, during the Handshake Protocol, pending read and write states are created. Upon successful conclusion of the Handshake Protocol, the pending states become the current states.

A session state is defined by the following parameters:

- **Session identifier:** An arbitrary byte sequence chosen by the server to identify an active or resumable session state.
- **Peer certificate:** An X509.v3 certificate of the peer. This element of the state may be null.

- **Compression method:** The algorithm used to compress data prior to encryption.
- **Cipher spec:** Specifies the bulk data encryption algorithm (such as null, AES, etc.) and a hash algorithm (such as MD5 or SHA-1) used for MAC calculation. It also defines cryptographic attributes such as the `hash_size`.
- **Master secret:** 48-byte secret shared between the client and server.
- **Is resumable:** A flag indicating whether the session can be used to initiate new connections.

A connection state is defined by the following parameters:

- **Server and client random:** Byte sequences that are chosen by the server and client for each connection.
- **Server write MAC secret:** The secret key used in MAC operations on data sent by the server.
- **Client write MAC secret:** The symmetric key used in MAC operations on data sent by the client.
- **Server write key:** The symmetric encryption key for data encrypted by the server and decrypted by the client.
- **Client write key:** The symmetric encryption key for data encrypted by the client and decrypted by the server.
- **Initialization vectors:** When a block cipher in CBC mode is used, an initialization vector (IV) is maintained for each key. This field is first initialized by the TLS Handshake Protocol. Thereafter, the final ciphertext block from each record is preserved for use as the IV with the following record.
- **Sequence numbers:** Each party maintains separate sequence numbers for transmitted and received messages for each connection. When a party sends or receives a “change cipher spec message,” the appropriate sequence number is set to zero. Sequence numbers may not exceed $2^{64} - 1$.

TLS Record Protocol

The TLS Record Protocol provides two services for TLS connections:

- **Confidentiality:** The Handshake Protocol defines a shared secret key that is used for conventional encryption of TLS payloads.
- **Message Integrity:** The Handshake Protocol also defines a shared secret key that is used to form a message authentication code (MAC).

Figure 17.3 indicates the overall operation of the TLS Record Protocol. The Record Protocol takes an application message to be transmitted, fragments the data into manageable blocks, optionally compresses the data, applies a MAC, encrypts, adds a header, and transmits the resulting unit in a TCP segment. Received data are decrypted, verified, decompressed, and reassembled before being delivered to higher-level users.

The first step is **fragmentation**. Each upper-layer message is fragmented into blocks of 2^{14} bytes (16,384 bytes) or less. Next, **compression** is optionally applied. Compression must be lossless and may not increase the content length by more than

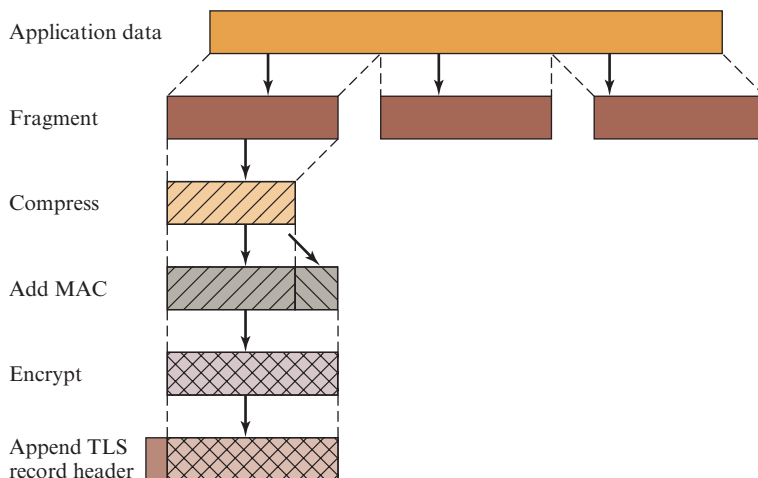

Figure 17.3 TLS Record Protocol Operation

1024 bytes.¹ In TLSv2, no compression algorithm is specified, so the default compression algorithm is null.

The next step in processing is to compute a **message authentication code** over the compressed data. TLS makes use of the HMAC algorithm defined in RFC 2104. Recall from Chapter 12 that HMAC is defined as

$$\text{HMAC}_K(M) = \text{H}[(K^+ \oplus \text{opad}) \parallel \text{H}[(K^+ \oplus \text{ipad}) \parallel M]]$$

where

H = embedded hash function (for TLS, either MD5 or SHA-1)

M = message input to HMAC

K^+ = secret key padded with zeros on the left so that the result is equal to the block length of the hash code (for MD5 and SHA-1, block length = 512 bits)

ipad = 00110110 (36 in hexadecimal) repeated 64 times (512 bits)

opad = 01011100 (5C in hexadecimal) repeated 64 times (512 bits)

For TLS, the MAC calculation encompasses the fields indicated in the following expression:

```
HMAC_hash(MAC_write_secret, seq_num || TLSCompressed.type ||
  TLSCompressed.version || TLSCompressed.length || TLSCompressed.fragment)
```

The MAC calculation covers all of the fields XXX, plus the field `TLSCompressed.version`, which is the version of the protocol being employed.

Next, the compressed message plus the MAC are **encrypted** using symmetric encryption. Encryption may not increase the content length by more than 1024 bytes,

¹Of course, one hopes that compression shrinks rather than expands the data. However, for very short blocks, it is possible, because of formatting conventions, that the compression algorithm will actually provide output that is longer than the input.

so that the total length may not exceed $2^{14} + 2048$. The following encryption algorithms are permitted:

Block Cipher		Stream Cipher	
Algorithm	Key Size	Algorithm	Key Size
AES	128, 256	RC4-128	128
3DES	168		

For stream encryption, the compressed message plus the MAC are encrypted. Note that the MAC is computed before encryption takes place and that the MAC is then encrypted along with the plaintext or compressed plaintext.

For block encryption, padding may be added after the MAC prior to encryption. The padding is in the form of a number of padding bytes followed by a one-byte indication of the length of the padding. The padding can be any amount that results in a total that is a multiple of the cipher's block length, up to a maximum of 255 bytes. For example, if the cipher block length is 16 bytes (e.g., AES) and if the plaintext (or compressed text if compression is used) plus MAC plus padding length byte is 79 bytes long, then the padding length (in bytes) can be 1, 17, 33, and so on, up to 161. At a padding length of 161, the total length is $79 + 161 = 240$. A variable padding length may be used to frustrate attacks based on an analysis of the lengths of exchanged messages.

The final step of TLS Record Protocol processing is to prepend a header consisting of the following fields:

- **Content Type (8 bits):** The higher-layer protocol used to process the enclosed fragment.
- **Major Version (8 bits):** Indicates major version of TLS in use. For TLSv2, the value is 3.
- **Minor Version (8 bits):** Indicates minor version in use. For TLSv2, the value is 1.
- **Compressed Length (16 bits):** The length in bytes of the plaintext fragment (or compressed fragment if compression is used). The maximum value is $2^{14} + 2048$.

The content types that have been defined are `change_cipher_spec`, `alert`, `handshake`, and `application_data`. The first three are the TLS-specific protocols, discussed next. Note that no distinction is made among the various applications (e.g., HTTP) that might use TLS; the content of the data created by such applications is opaque to TLS.

Figure 17.4 illustrates the TLS record format.

Change Cipher Spec Protocol

The Change Cipher Spec Protocol is one of the four TLS-specific protocols that use the TLS Record Protocol, and it is the simplest. This protocol consists of a single message (Figure 17.5a), which consists of a single byte with the value 1. The sole purpose of this message is to cause the pending state to be copied into the current state, which updates the cipher suite to be used on this connection.

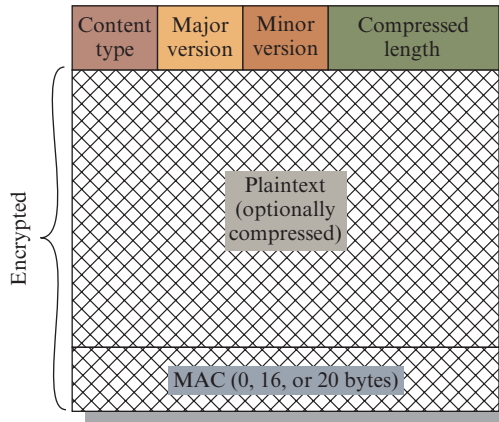

Figure 17.4 TLS Record Format

Alert Protocol

The Alert Protocol is used to convey TLS-related alerts to the peer entity. As with other applications that use TLS, alert messages are compressed and encrypted, as specified by the current state.

Each message in this protocol consists of two bytes (Figure 17.5b). The first byte takes the value warning (1) or fatal (2) to convey the severity of the message. If the level is fatal, TLS immediately terminates the connection. Other connections on the same session may continue, but no new connections on this session may be established. The second byte contains a code that indicates the specific alert.

Examples of fatal alerts are `bad_record_mac` (an incorrect MAC was received) and `handshake_failure` (sender was unable to negotiate an acceptable set of security parameters given the options available). An example of a warning alert is `unsupported_certificate` (the type of the received certificate is not supported).

Handshake Protocol

The most complex part of TLS is the Handshake Protocol. This protocol allows the server and client to authenticate each other and to negotiate an encryption and MAC algorithm and cryptographic keys to be used to protect data sent in a TLS record. The Handshake Protocol is used before any application data is transmitted.

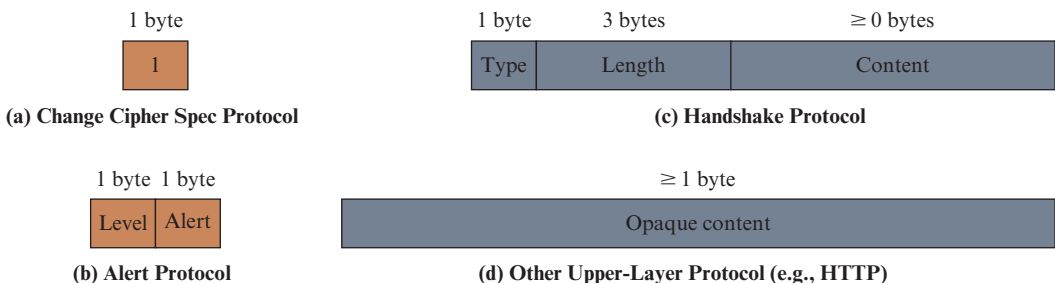

Figure 17.5 TLS Record Protocol Payload

The Handshake Protocol consists of a series of messages exchanged by client and server. All of these have the format shown in Figure 17.5c. Each message has three fields:

- **Type (1 byte):** Indicates one of 10 messages. Table 17.2 lists the defined message types.
- **Length (3 bytes):** The length of the message in bytes.
- **Content (≥ 0 bytes):** The parameters associated with this message; these are listed in Table 17.2.

Figure 17.6 shows the initial exchange needed to establish a logical connection between client and server. The exchange can be viewed as having four phases.

PHASE 1. ESTABLISH SECURITY CAPABILITIES Phase 1 initiates a logical connection and establishes the security capabilities that will be associated with it. The exchange is initiated by the client, which sends a **client_hello message** with the following parameters:

- **Version:** The highest TLS version understood by the client.
- **Random:** A client-generated random structure consisting of a 32-bit timestamp and 28 bytes generated by a secure random number generator. These values serve as nonces and are used during key exchange to prevent replay attacks.
- **Session ID:** A variable-length session identifier. A nonzero value indicates that the client wishes to update the parameters of an existing connection or to create a new connection on this session. A zero value indicates that the client wishes to establish a new connection on a new session.
- **CipherSuite:** This is a list that contains the combinations of cryptographic algorithms supported by the client, in decreasing order of preference. Each element of the list (each cipher suite) defines both a key exchange algorithm and a CipherSpec; these are discussed subsequently.
- **Compression Method:** This is a list of the compression methods the client supports.

Table 17.2 TLS Handshake Protocol Message Types

Message Type	Parameters
<code>hello_request</code>	null
<code>client_hello</code>	version, random, session id, cipher suite, compression method
<code>server_hello</code>	version, random, session id, cipher suite, compression method
<code>certificate</code>	chain of X.509v3 certificates
<code>server_key_exchange</code>	parameters, signature
<code>certificate_request</code>	type, authorities
<code>server_done</code>	null
<code>certificate_verify</code>	signature
<code>client_key_exchange</code>	parameters, signature
<code>finished</code>	hash value

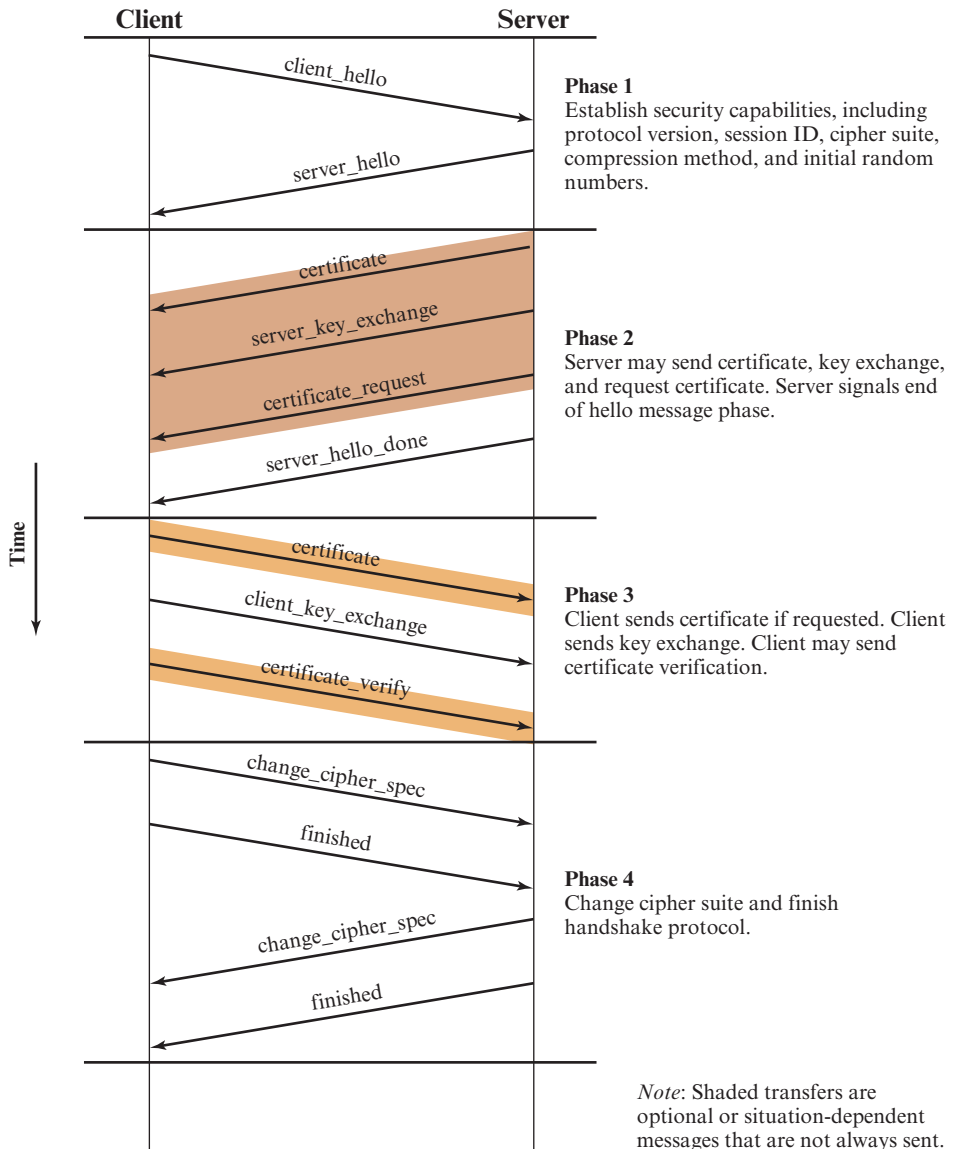

Figure 17.6 Handshake Protocol Action

After sending the `client_hello` message, the client waits for the **server_hello message**, which contains the same parameters as the `client_hello` message. For the `server_hello` message, the following conventions apply. The Version field contains the lowest of the version suggested by the client and the highest supported by the server. The Random field is generated by the server and is independent of the client's Random field. If the SessionID field of the client was nonzero, the same value is used by the server; otherwise the server's SessionID field contains the value for a new session. The CipherSuite field contains the single cipher suite selected

by the server from those proposed by the client. The Compression field contains the compression method selected by the server from those proposed by the client.

The first element of the Ciphersuite parameter is the key exchange method (i.e., the means by which the cryptographic keys for conventional encryption and MAC are exchanged). The following key exchange methods are supported.

- **RSA:** The secret key is encrypted with the receiver's RSA public key. A public-key certificate for the receiver's key must be made available.
- **Fixed Diffie–Hellman:** This is a Diffie–Hellman key exchange in which the server's certificate contains the Diffie–Hellman public parameters signed by the certificate authority (CA). That is, the public-key certificate contains the Diffie–Hellman public-key parameters. The client provides its Diffie–Hellman public-key parameters either in a certificate, if client authentication is required, or in a key exchange message. This method results in a fixed secret key between two peers based on the Diffie–Hellman calculation using the fixed public keys.
- **Ephemeral Diffie–Hellman:** This technique is used to create ephemeral (temporary, one-time) secret keys. In this case, the Diffie–Hellman public keys are exchanged and signed using the sender's private RSA or DSS key. The receiver can use the corresponding public key to verify the signature. Certificates are used to authenticate the public keys. This would appear to be the most secure of the three Diffie–Hellman options because it results in a temporary, authenticated key.
- **Anonymous Diffie–Hellman:** The base Diffie–Hellman algorithm is used with no authentication. That is, each side sends its public Diffie–Hellman parameters to the other with no authentication. This approach is vulnerable to man-in-the-middle attacks, in which the attacker conducts anonymous Diffie–Hellman with both parties.

Following the definition of a key exchange method is the CipherSpec, which includes the following fields:

- **CipherAlgorithm:** Any of the algorithms mentioned earlier: RC4, RC2, DES, 3DES, DES40, or IDEA
- **MACAlgorithm:** MD5 or SHA-1
- **CipherType:** Stream or Block
- **IsExportable:** True or False
- **HashSize:** 0, 16 (for MD5), or 20 (for SHA-1) bytes
- **Key Material:** A sequence of bytes that contain data used in generating the write keys
- **IV Size:** The size of the Initialization Value for Cipher Block Chaining (CBC) encryption

PHASE 2. SERVER AUTHENTICATION AND KEY EXCHANGE The server begins this phase by sending its certificate if it needs to be authenticated; the message contains one or a chain of X.509 certificates. The **certificate message** is required for any agreed-on key exchange method except anonymous Diffie–Hellman. Note

that if fixed Diffie–Hellman is used, this certificate message functions as the server’s key exchange message because it contains the server’s public Diffie–Hellman parameters.

Next, a **server_key_exchange message** may be sent if it is required. It is not required in two instances: (1) The server has sent a certificate with fixed Diffie–Hellman parameters; or (2) RSA key exchange is to be used. The server_key_exchange message is needed for the following:

- **Anonymous Diffie–Hellman:** The message content consists of the two global Diffie–Hellman values (a prime number and a primitive root of that number) plus the server’s public Diffie–Hellman key (see Figure 10.1).
- **Ephemeral Diffie–Hellman:** The message content includes the three Diffie–Hellman parameters provided for anonymous Diffie–Hellman plus a signature of those parameters.
- **RSA key exchange (in which the server is using RSA but has a signature-only RSA key):** Accordingly, the client cannot simply send a secret key encrypted with the server’s public key. Instead, the server must create a temporary RSA public/private key pair and use the server_key_exchange message to send the public key. The message content includes the two parameters of the temporary RSA public key (exponent and modulus; see Figure 9.5) plus a signature of those parameters.

Some further details about the signatures are warranted. As usual, a signature is created by taking the hash of a message and encrypting it with the sender’s private key. In this case, the hash is defined as

$$\text{hash}(\text{ClientHello.random} \parallel \text{ServerHello.random} \parallel \text{ServerParams})$$

So the hash covers not only the Diffie–Hellman or RSA parameters but also the two nonces from the initial hello messages. This ensures against replay attacks and misrepresentation. In the case of a DSS signature, the hash is performed using the SHA-1 algorithm. In the case of an RSA signature, both an MD5 and an SHA-1 hash are calculated, and the concatenation of the two hashes (36 bytes) is encrypted with the server’s private key.

Next, a nonanonymous server (server not using anonymous Diffie–Hellman) can request a certificate from the client. The **certificate_request message** includes two parameters: certificate_type and certificate_authorities. The certificate type indicates the public-key algorithm and its use:

- RSA, signature only
- DSS, signature only
- RSA for fixed Diffie–Hellman; in this case the signature is used only for authentication, by sending a certificate signed with RSA
- DSS for fixed Diffie–Hellman; again, used only for authentication

The second parameter in the certificate_request message is a list of the distinguished names of acceptable certificate authorities.

The final message in phase 2, and one that is always required, is the **server_done message**, which is sent by the server to indicate the end of the server hello and associated messages. After sending this message, the server will wait for a client response. This message has no parameters.

PHASE 3. CLIENT AUTHENTICATION AND KEY EXCHANGE Upon receipt of the `server_done` message, the client should verify that the server provided a valid certificate (if required) and check that the `server_hello` parameters are acceptable. If all is satisfactory, the client sends one or more messages back to the server.

If the server has requested a certificate, the client begins this phase by sending a **certificate message**. If no suitable certificate is available, the client sends a `no_certificate` alert instead.

Next is the **client_key_exchange message**, which must be sent in this phase. The content of the message depends on the type of key exchange, as follows:

- **RSA:** The client generates a 48-byte *pre-master secret* and encrypts with the public key from the server's certificate or temporary RSA key from a `server_key_exchange` message. Its use to compute a *master secret* is explained later.
- **Ephemeral or Anonymous Diffie–Hellman:** The client's public Diffie–Hellman parameters are sent.
- **Fixed Diffie–Hellman:** The client's public Diffie–Hellman parameters were sent in a certificate message, so the content of this message is null.

Finally, in this phase, the client may send a **certificate_verify message** to provide explicit verification of a client certificate. This message is only sent following any client certificate that has signing capability (i.e., all certificates except those containing fixed Diffie–Hellman parameters). This message signs a hash code based on the preceding messages, defined as

```
CertificateVerify.signature.md5_hash
    MD5(handshake_messages);
Certificate.signature.sha_hash
    SHA(handshake_messages);
```

where `handshake_messages` refers to all Handshake Protocol messages sent or received starting at `client_hello` but not including this message. If the user's private key is DSS, then it is used to encrypt the SHA-1 hash. If the user's private key is RSA, it is used to encrypt the concatenation of the MD5 and SHA-1 hashes. In either case, the purpose is to verify the client's ownership of the private key for the client certificate. Even if someone is misusing the client's certificate, he or she would be unable to send this message.

PHASE 4. FINISH Phase 4 completes the setting up of a secure connection. The client sends a **change_cipher_spec message** and copies the pending CipherSpec into the current CipherSpec. Note that this message is not considered part of the Handshake Protocol but is sent using the Change Cipher Spec Protocol. The client then immediately sends the **finished message** under the new algorithms, keys, and secrets.

The finished message verifies that the key exchange and authentication processes were successful. The content of the finished message is:

$$\text{PRF}(\text{master_secret}, \text{finished_label}, \text{MD5}(\text{handshake_messages}) \parallel \text{SHA-1}(\text{handshake_messages}))$$

where `finished_label` is the string “client finished” for the client and “server finished” for the server.

In response to these two messages, the server sends its own `change_cipher_spec` message, transfers the pending to the current CipherSpec, and sends its finished message. At this point, the handshake is complete and the client and server may begin to exchange application-layer data.

Cryptographic Computations

Two further items are of interest: (1) the creation of a shared master secret by means of the key exchange; and (2) the generation of cryptographic parameters from the master secret.

MASTER SECRET CREATION The shared master secret is a one-time 48-byte value (384 bits) generated for this session by means of secure key exchange. The creation is in two stages. First, a `pre_master_secret` is exchanged. Second, the `master_secret` is calculated by both parties. For `pre_master_secret` exchange, there are two possibilities.

- **RSA:** A 48-byte `pre_master_secret` is generated by the client, encrypted with the server’s public RSA key, and sent to the server. The server decrypts the ciphertext using its private key to recover the `pre_master_secret`.
- **Diffie–Hellman:** Both client and server generate a Diffie–Hellman public key. After these are exchanged, each side performs the Diffie–Hellman calculation to create the shared `pre_master_secret`.

Both sides now compute the `master_secret` as

$$\text{master_secret} = \text{PRF}(\text{pre_master_secret}, \text{“master secret”}, \text{ClientHello.random} \parallel \text{ServerHello.random})$$

where `ClientHello.random` and `ServerHello.random` are the two nonce values exchanged in the initial hello messages.

The algorithm is performed until 48 bytes of pseudorandom output are produced. The calculation of the key block material (MAC secret keys, session encryption keys, and IVs) is defined as

$$\text{key_block} = \text{PRF}(\text{SecurityParameters.master_secret}, \text{“key expansion”}, \text{SecurityParameters.server_random} \parallel \text{SecurityParameters.client_random})$$

until enough output has been generated.

GENERATION OF CRYPTOGRAPHIC PARAMETERS CipherSpecs require a client write MAC secret, a server write MAC secret, a client write key, a server write key, a client write IV, and a server write IV, which are generated from the master secret in that order. These parameters are generated from the master secret by hashing the master secret into a sequence of secure bytes of sufficient length for all needed parameters.

The generation of the key material from the master secret uses the same format for generation of the master secret from the pre-master secret as

$$\begin{aligned} \text{key_block} = & \text{MD5}(\text{master_secret} \parallel \text{SHA}(\text{'A'} \parallel \text{master_secret} \parallel \\ & \text{ServerHello.random} \parallel \text{ClientHello.random})) \parallel \\ & \text{MD5}(\text{master_secret} \parallel \text{SHA}(\text{'BB'} \parallel \text{master_secret} \parallel \\ & \text{ServerHello.random} \parallel \text{ClientHello.random})) \parallel \\ & \text{MD5}(\text{master_secret} \parallel \text{SHA}(\text{'CCC'} \parallel \text{master_secret} \parallel \\ & \text{ServerHello.random} \parallel \text{ClientHello.random})) \parallel \dots \end{aligned}$$

until enough output has been generated. The result of this algorithmic structure is a pseudorandom function. We can view the `master_secret` as the pseudorandom seed value to the function. The client and server random numbers can be viewed as salt values to complicate cryptanalysis (see Chapter 21 for a discussion of the use of salt values).

PSEUDORANDOM FUNCTION TLS makes use of a pseudorandom function referred to as PRF to expand secrets into blocks of data for purposes of key generation or validation. The objective is to make use of a relatively small, shared secret value but to generate longer blocks of data in a way that is secure from the kinds of attacks made on hash functions and MACs. The PRF is based on the data expansion function (Figure 17.7) given as

$$\begin{aligned} \text{P_hash}(\text{secret}, \text{seed}) = & \text{HMAC_hash}(\text{secret}, \text{A}(1) \parallel \text{seed}) \parallel \\ & \text{HMAC_hash}(\text{secret}, \text{A}(2) \parallel \text{seed}) \parallel \\ & \text{HMAC_hash}(\text{secret}, \text{A}(3) \parallel \text{seed}) \parallel \end{aligned}$$

where $\text{A}()$ is defined as

$$\begin{aligned} \text{A}(0) &= \text{seed} \\ \text{A}(i) &= \text{HMAC_hash}(\text{secret}, \text{A}(i - 1)) \end{aligned}$$

The data expansion function makes use of the HMAC algorithm with either MD5 or SHA-1 as the underlying hash function. As can be seen, `P_hash` can be iterated as many times as necessary to produce the required quantity of data. For example, if `P_SHA256` was used to generate 80 bytes of data, it would have to be iterated three times (through $\text{A}(3)$), producing 96 bytes of data of which the last 16 would be discarded. In this case, `P_MD5` would have to be iterated four times, producing exactly 64 bytes of data. Note that each iteration involves two executions of HMAC, each of which in turn involves two executions of the underlying hash algorithm.

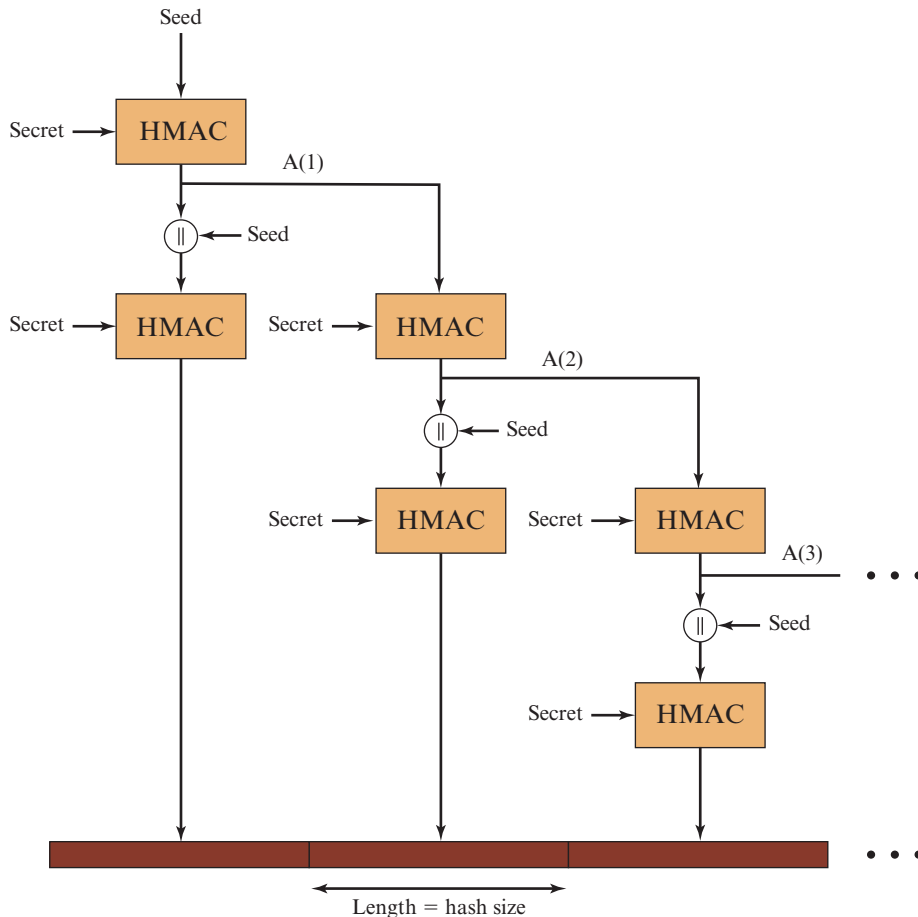

Figure 17.7 TLS Function $P_{\text{hash}}(\text{secret}, \text{seed})$

To make PRF as secure as possible, it uses two hash algorithms in a way that should guarantee its security if either algorithm remains secure. PRF is defined as

$$\text{PRF}(\text{secret}, \text{label}, \text{seed}) = P_{\langle \text{hash} \rangle}(\text{secret}, \text{label} \parallel \text{seed})$$

PRF takes as input a secret value, an identifying label, and a seed value and produces an output of arbitrary length.

SSL/TLS ATTACKS

Since the first introduction of SSL in 1994, and the subsequent standardization of TLS, numerous attacks have been devised against these protocols. The appearance of each attack has necessitated changes in the protocol, the encryption tools used, or some aspect of the implementation of SSL and TLS to counter these threats.

ATTACK CATEGORIES We can group the attacks into four general categories:

- **Attacks on the handshake protocol:** As early as 1998, an approach to compromising the handshake protocol based on exploiting the formatting and implementation of the RSA encryption scheme was presented [BLEI98]. As countermeasures were implemented the attack was refined and adjusted to not only thwart the countermeasures but also speed up the attack [e.g., BARD12].
- **Attacks on the record and application data protocols:** A number of vulnerabilities have been discovered in these protocols, leading to patches to counter the new threats. As a recent example, in 2011, researchers Thai Duong and Juliano Rizzo demonstrated a proof of concept called BEAST (Browser Exploit Against SSL/TLS) that turned what had been considered only a theoretical vulnerability into a practical attack [GOOD11]. BEAST leverages a type of cryptographic attack called a chosen-plaintext attack. The attacker mounts the attack by choosing a guess for the plaintext that is associated with a known ciphertext. The researchers developed a practical algorithm for launching successful attacks. Subsequent patches were able to thwart this attack. The authors of the BEAST attack are also the creators of the 2012 CRIME (Compression Ratio Info-leak Made Easy) attack, which can allow an attacker to recover the content of web cookies when data compression is used along with TLS [GOOD12]. When used to recover the content of secret authentication cookies, it allows an attacker to perform session hijacking on an authenticated web session.
- **Attacks on the PKI:** Checking the validity of X.509 certificates is an activity subject to a variety of attacks, both in the context of SSL/TLS and elsewhere. For example, [GEOR12] demonstrated that commonly used libraries for SSL/TLS suffer from vulnerable certificate validation implementations. The authors revealed weaknesses in the source code of OpenSSL, GnuTLS, JSSE, ApacheHttpClient, Weberknecht, cURL, PHP, Python and applications built upon or with these products.
- **Other attacks:** [MEYE13] lists a number of attacks that do not fit into any of the preceding categories. One example is an attack announced in 2011 by the German hacker group The Hackers Choice, which is a DoS attack [KUMA11b]. The attack creates a heavy processing load on a server by overwhelming the target with SSL/TLS handshake requests. Boosting system load is done by establishing new connections or using renegotiation. Assuming that the majority of computation during a handshake is done by the server, the attack creates more system load on the server than on the source device, leading to a DoS. The server is forced to continuously recompute random numbers and keys.

The history of attacks and countermeasures for SSL/TLS is representative of that for other Internet-based protocols. A “perfect” protocol and a “perfect” implementation strategy are never achieved. A constant back-and-forth between threats and countermeasures determines the evolution of Internet-based protocols.

TLSv1.3

In 2014, the IETF TLS working group began work on a version 1.3 of TLS. The primary aim is to improve the security of TLS. As of this writing, TLSv1.3 is still in a draft stage, but the final standard is likely to be very close to the current draft. Among the significant changes from version 1.2 are the following:

- TLSv1.3 removes support for a number of options and functions. Removing code that implements functions no longer needed reduces the chances of potentially dangerous coding errors and reduces the attack surface. The deleted items include:
 - Compression
 - Ciphers that do not offer authenticated encryption
 - Static RSA and DH key exchange
 - 32-bit timestamp as part of the Random parameter in the client_hello message
 - Renegotiation
 - Change Cipher Spec Protocol
 - RC4
 - Use of MD5 and SHA-224 hashes with signatures
- TLSv1.3 uses Diffie–Hellman or Elliptic Curve Diffie–Hellman for key exchange and does not permit RSA. The danger with RSA is that if the private key is compromised, all handshakes using these cipher suites will be compromised. With DH or ECDH, a new key is negotiated for each handshake.
- TLSv1.3 allows for a “1 round trip time” handshake by changing the order of message sent with establishing a secure connection. The client sends a Client Key Exchange message containing its cryptographic parameters for key establishment before a cipher suite has been negotiated. This enables a server to calculate keys for encryption and authentication before sending its first response. Reducing the number of packets sent during this handshake phase speeds up the process and reduces the attack surface.

These changes should improve the efficiency and security of TLS.

17.3 HTTPS

Hyper Text Transfer Protocol Secure (HTTPS) is the secure version of HTTP. HTTPS encrypts all communications between the browser and the website. Web browsers such as Safari, Firefox, and Chrome also display a padlock icon in the address bar to visually indicate that a HTTPS connection is in effect.

Data sent using HTTPS provides three important areas of protection:

- **Encryption:** Encrypts the exchanged data to keep it secure from eavesdroppers. The encryption covers the URL of the requested document, the contents of the document, the contents of browser forms (filled in by browser user), the cookies sent from browser to server and from server to browser, and the contents of the HTTP header.

- **Data integrity:** Data cannot be modified or corrupted during transfer, intentionally or otherwise, without being detected.
- **Authentication:** Proves that your users communicate with the intended website. It protects against man-in-the-middle attacks and builds user trust, which translates into other business benefits.

Connection Initiation

For HTTPS, the agent acting as the HTTP client also acts as the TLS client. The client initiates a connection to the server on the appropriate port and then sends the TLS ClientHello to begin the TLS handshake. When the TLS handshake has finished, the client may then initiate the first HTTP request. All HTTP data is to be sent as TLS application data. Normal HTTP behavior, including retained connections, should be followed.

There are three levels of awareness of a connection in HTTPS. At the HTTP level, an HTTP client requests a connection to an HTTP server by sending a connection request to the next lowest layer. Typically, the next lowest layer is TCP, but it also may be TLS/SSL. At the level of TLS, a session is established between a TLS client and a TLS server. This session can support one or more connections at any time. As we have seen, a TLS request to establish a connection begins with the establishment of a TCP connection between the TCP entity on the client side and the TCP entity on the server side.

Connection Closure

An HTTP client or server can indicate the closing of a connection by including the following line in an HTTP record: `Connection: close`. This indicates that the connection will be closed after this record is delivered.

The closure of an HTTPS connection requires that TLS close the connection with the peer TLS entity on the remote side, which will involve closing the underlying TCP connection. At the TLS level, the proper way to close a connection is for each side to use the TLS alert protocol to send a `close_notify` alert. TLS implementations must initiate an exchange of closure alerts before closing a connection. A TLS implementation may, after sending a closure alert, close the connection without waiting for the peer to send its closure alert, generating an “incomplete close.” Note that an implementation that does this may choose to reuse the session. This should only be done when the application knows (typically through detecting HTTP message boundaries) that it has received all the message data that it cares about.

HTTP clients also must be able to cope with a situation in which the underlying TCP connection is terminated without a prior `close_notify` alert and without a `Connection: close` indicator. Such a situation could be due to a programming error on the server or a communication error that causes the TCP connection to drop. However, the unannounced TCP closure could be evidence of some sort of attack. So the HTTPS client should issue some sort of security warning when this occurs.

17.4 SECURE SHELL (SSH)

Secure Shell (SSH) is a protocol for secure network communications designed to be relatively simple and inexpensive to implement. The initial version, SSH1 was focused on providing a secure remote logon facility to replace TELNET and other remote logon schemes that provided no security. SSH also provides a more general client/server capability and can be used for such network functions as file transfer and email. A new version, SSH2, fixes a number of security flaws in the original scheme. SSH2 is documented as a proposed standard in IETF RFCs 4250 through 4256.

SSH client and server applications are widely available for most operating systems. It has become the method of choice for remote login and X tunneling and is rapidly becoming one of the most pervasive applications for encryption technology outside of embedded systems.

SSH is organized as three protocols that typically run on top of TCP (Figure 17.8):

- **Transport Layer Protocol:** Provides server authentication, data confidentiality, and data integrity with forward secrecy (i.e., if a key is compromised during one session, the knowledge does not affect the security of earlier sessions). The transport layer may optionally provide compression.
- **User Authentication Protocol:** Authenticates the user to the server.
- **Connection Protocol:** Multiplexes multiple logical communications channels over a single, underlying SSH connection.

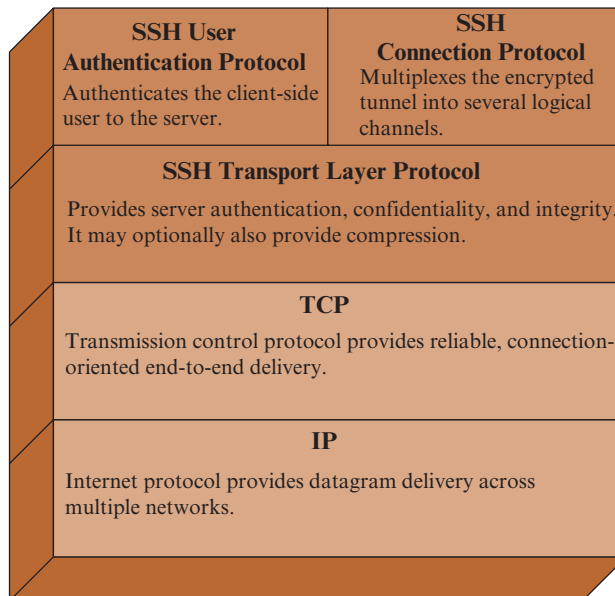

Figure 17.8 SSH Protocol Stack

Transport Layer Protocol

HOST KEYS Server authentication occurs at the transport layer, based on the server possessing a public/private key pair. A server may have multiple host keys using multiple different asymmetric encryption algorithms. Multiple hosts may share the same host key. In any case, the server host key is used during key exchange to authenticate the identity of the host. For this to be possible, the client must have a priori knowledge of the server's public host key. RFC 4251 dictates two alternative trust models that can be used:

1. The client has a local database that associates each host name (as typed by the user) with the corresponding public host key. This method requires no centrally administered infrastructure and no third-party coordination. The downside is that the database of name-to-key associations may become burdensome to maintain.
2. The host name-to-key association is certified by a trusted certification authority (CA). The client only knows the CA root key and can verify the validity of all host keys certified by accepted CAs. This alternative eases the maintenance problem, since ideally, only a single CA key needs to be securely stored on the client. On the other hand, each host key must be appropriately certified by a central authority before authorization is possible.

PACKET EXCHANGE Figure 17.9 illustrates the sequence of events in the SSH Transport Layer Protocol. First, the client establishes a TCP connection to the server. This is done via the TCP protocol and is not part of the Transport Layer Protocol. Once the connection is established, the client and server exchange data, referred to as packets, in the data field of a TCP segment. Each packet is in the following format (Figure 17.10).

- **Packet length:** Length of the packet in bytes, not including the packet length and MAC fields.
- **Padding length:** Length of the random padding field.
- **Payload:** Useful contents of the packet. Prior to algorithm negotiation, this field is uncompressed. If compression is negotiated, then in subsequent packets, this field is compressed.
- **Random padding:** Once an encryption algorithm has been negotiated, this field is added. It contains random bytes of padding so that the total length of the packet (excluding the MAC field) is a multiple of the cipher block size, or 8 bytes for a stream cipher.
- **Message authentication code (MAC):** If message authentication has been negotiated, this field contains the MAC value. The MAC value is computed over the entire packet plus a sequence number, excluding the MAC field. The sequence number is an implicit 32-bit packet sequence that is initialized to zero for the first packet and incremented for every packet. The sequence number is not included in the packet sent over the TCP connection.

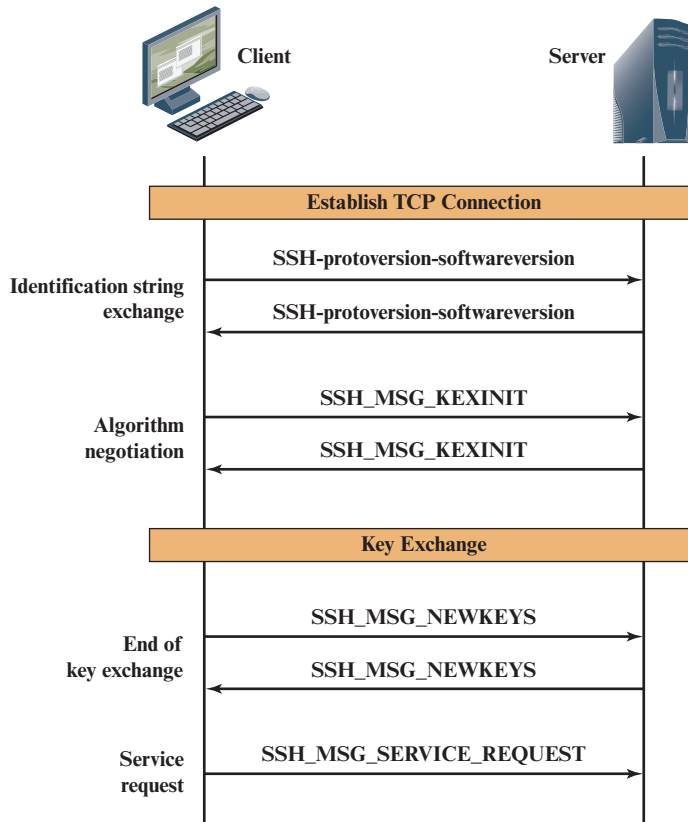

Figure 17.9 SSH Transport Layer Protocol Packet Exchanges

Once an encryption algorithm has been negotiated, the entire packet (excluding the MAC field) is encrypted after the MAC value is calculated.

The SSH Transport Layer packet exchange consists of a sequence of steps (Figure 17.9). The first step, the **identification string exchange**, begins with the client sending a packet with an identification string of the form:

```
SSH-protoversion-softwareversion SP comments CR LF
```

where *SP*, *CR*, and *LF* are space character, carriage return, and line feed, respectively. An example of a valid string is `SSH-2.0-billsSSH_3.6.3q3<CR><LF>`. The server responds with its own identification string. These strings are used in the Diffie–Hellman key exchange.

Next comes **algorithm negotiation**. Each side sends an `SSH_MSG_KEXINIT` containing lists of supported algorithms in the order of preference to the sender. There is one list for each type of cryptographic algorithm. The algorithms include key exchange, encryption, MAC algorithm, and compression algorithm.

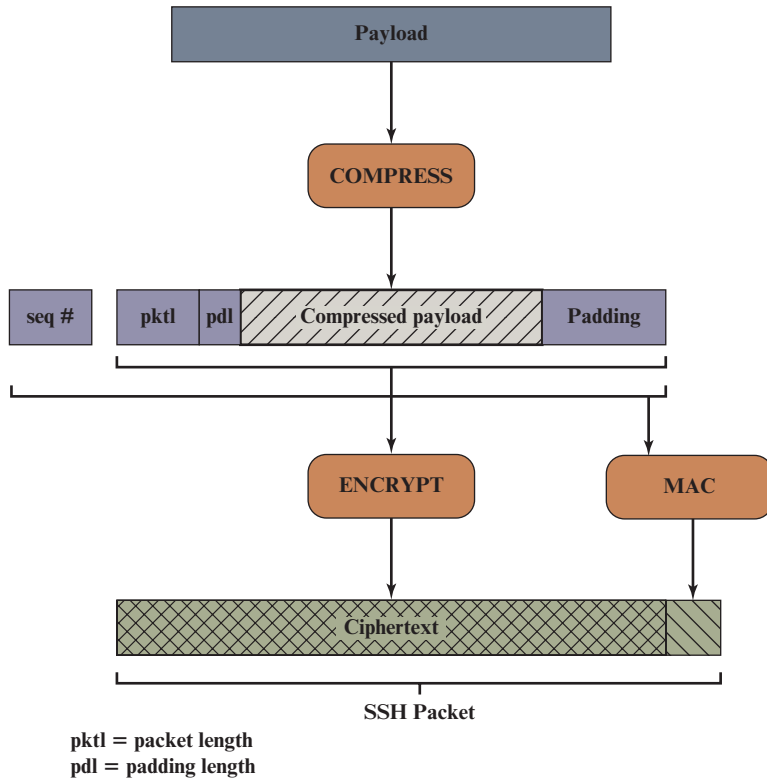

Figure 17.10 SSH Transport Layer Protocol Packet Formation

Table 17.3 shows the allowable options for encryption, MAC, and compression. For each category, the algorithm chosen is the first algorithm on the client's list that is also supported by the server.

The next step is **key exchange**. The specification allows for alternative methods of key exchange, but at present, only two versions of Diffie–Hellman key exchange are specified. Both versions are defined in RFC 2409 and require only one packet in each direction. The following steps are involved in the exchange. In this, C is the client; S is the server; p is a large safe prime; g is a generator for a subgroup of $GF(p)$; q is the order of the subgroup; V_S is S's identification string; V_C is C's identification string; K_S is S's public host key; I_C is C's `SSH_MSG_KEXINIT` message and I_S is S's `SSH_MSG_KEXINIT` message that have been exchanged before this part begins. The values of p , g , and q are known to both client and server as a result of the algorithm selection negotiation. The hash function `hash()` is also decided during algorithm negotiation.

1. C generates a random number x ($1 < x < q$) and computes $e = g^x \bmod p$. C sends e to S.
2. S generates a random number y ($0 < y < q$) and computes $f = g^y \bmod p$. S receives e . It computes $K = e^y \bmod p$, $H = \text{hash}(V_C \| V_S \| I_C \| I_S \| K_S \|$

Table 17.3 SSH Transport Layer Cryptographic Algorithms

Cipher	
3des-cbc*	Three-key 3DES in CBC mode
blowfish-cbc	Blowfish in CBC mode
twofish256-cbc	Twofish in CBC mode with a 256-bit key
twofish192-cbc	Twofish with a 192-bit key
twofish128-cbc	Twofish with a 128-bit key
aes256-cbc	AES in CBC mode with a 256-bit key
aes192-cbc	AES with a 192-bit key
aes128-cbc**	AES with a 128-bit key
Serpent256-cbc	Serpent in CBC mode with a 256-bit key
Serpent192-cbc	Serpent with a 192-bit key
Serpent128-cbc	Serpent with a 128-bit key
arcfour	RC4 with a 128-bit key
cast128-cbc	CAST-128 in CBC mode

MAC algorithm	
hmac-sha1*	HMAC-SHA1; digest length = key length = 20
hmac-sha1-96**	First 96 bits of HMAC-SHA1; digest length = 12; key length = 20
hmac-md5	HMAC-MD5; digest length = key length = 16
hmac-md5-96	First 96 bits of HMAC-MD5; digest length = 12; key length = 16

Compression algorithm	
none*	No compression
zlib	Defined in RFC 1950 and RFC 1951

* = Required

** = Recommended

$e\|f\|K$), and signature s on H with its private host key. S sends $(K_S\|f\|s)$ to C. The signing operation may involve a second hashing operation.

3. C verifies that K_S really is the host key for S (e.g., using certificates or a local database). C is also allowed to accept the key without verification; however, doing so will render the protocol insecure against active attacks (but may be desirable for practical reasons in the short term in many environments). C then computes $K = f^x \bmod p$, $H = \text{hash}(V_C\|V_S\|I_C\|I_S\|K_S\|e\|f\|K)$, and verifies the signature s on H .

As a result of these steps, the two sides now share a master key K . In addition, the server has been authenticated to the client, because the server has used its private key to sign its half of the Diffie-Hellman exchange. Finally, the hash value H serves as a session identifier for this connection. Once computed, the session identifier is not changed, even if the key exchange is performed again for this connection to obtain fresh keys.

The **end of key exchange** is signaled by the exchange of `SSH_MSG_NEWKEYS` packets. At this point, both sides may start using the keys generated from K , as discussed subsequently.

The final step is **service request**. The client sends an `SSH_MSG_SERVICE_REQUEST` packet to request either the User Authentication or the Connection Protocol. Subsequent to this, all data is exchanged as the payload of an SSH Transport Layer packet, protected by encryption and MAC.

KEY GENERATION The keys used for encryption and MAC (and any needed IVs) are generated from the shared secret key K , the hash value from the key exchange H , and the session identifier, which is equal to H unless there has been a subsequent key exchange after the initial key exchange. The values are computed as follows.

- Initial IV client to server: $\text{HASH}(K \| H \| \text{"A"} \| \text{session_id})$
- Initial IV server to client: $\text{HASH}(K \| H \| \text{"B"} \| \text{session_id})$
- Encryption key client to server: $\text{HASH}(K \| H \| \text{"C"} \| \text{session_id})$
- Encryption key server to client: $\text{HASH}(K \| H \| \text{"D"} \| \text{session_id})$
- Integrity key client to server: $\text{HASH}(K \| H \| \text{"E"} \| \text{session_id})$
- Integrity key server to client: $\text{HASH}(K \| H \| \text{"F"} \| \text{session_id})$

where $\text{HASH}()$ is the hash function determined during algorithm negotiation.

User Authentication Protocol

The User Authentication Protocol provides the means by which the client is authenticated to the server.

MESSAGE TYPES AND FORMATS Three types of messages are always used in the User Authentication Protocol. Authentication requests from the client have the format:

byte	<code>SSH_MSG_USERAUTH_REQUEST</code> (50)
string	user name
string	service name
string	method name
...	method specific fields

where user name is the authorization identity the client is claiming, service name is the facility to which the client is requesting access (typically the SSH Connection Protocol), and method name is the authentication method being used in this request. The first byte has decimal value 50, which is interpreted as `SSH_MSG_USERAUTH_REQUEST`.

If the server either (1) rejects the authentication request or (2) accepts the request but requires one or more additional authentication methods, the server sends a message with the format:

byte	<code>SSH_MSG_USERAUTH_FAILURE</code> (51)
name-list	authentications that can continue
boolean	partial success

where the name-list is a list of methods that may productively continue the dialog. If the server accepts authentication, it sends a single byte message: `SSH_MSG_USERAUTH_SUCCESS` (52).

MESSAGE EXCHANGE The message exchange involves the following steps.

1. The client sends a `SSH_MSG_USERAUTH_REQUEST` with a requested method of none.
2. The server checks to determine if the user name is valid. If not, the server returns `SSH_MSG_USERAUTH_FAILURE` with the partial success value of false. If the user name is valid, the server proceeds to step 3.
3. The server returns `SSH_MSG_USERAUTH_FAILURE` with a list of one or more authentication methods to be used.
4. The client selects one of the acceptable authentication methods and sends a `SSH_MSG_USERAUTH_REQUEST` with that method name and the required method-specific fields. At this point, there may be a sequence of exchanges to perform the method.
5. If the authentication succeeds and more authentication methods are required, the server proceeds to step 3, using a partial success value of true. If the authentication fails, the server proceeds to step 3, using a partial success value of false.
6. When all required authentication methods succeed, the server sends a `SSH_MSG_USERAUTH_SUCCESS` message, and the Authentication Protocol is over.

AUTHENTICATION METHODS The server may require one or more of the following authentication methods.

- **publickey:** The details of this method depend on the public-key algorithm chosen. In essence, the client sends a message to the server that contains the client's public key, with the message signed by the client's private key. When the server receives this message, it checks whether the supplied key is acceptable for authentication and, if so, it checks whether the signature is correct.
- **password:** The client sends a message containing a plaintext password, which is protected by encryption by the Transport Layer Protocol.
- **hostbased:** Authentication is performed on the client's host rather than the client itself. Thus, a host that supports multiple clients would provide authentication for all its clients. This method works by having the client send a signature created with the private key of the client host. Thus, rather than directly verifying the user's identity, the SSH server verifies the identity of the client host—and then believes the host when it says the user has already authenticated on the client side.

Connection Protocol

The SSH Connection Protocol runs on top of the SSH Transport Layer Protocol and assumes that a secure authentication connection is in use.² That secure authentication connection, referred to as a **tunnel**, is used by the Connection Protocol to multiplex a number of logical channels.

CHANNEL MECHANISM All types of communication using SSH, such as a terminal session, are supported using separate channels. Either side may open a channel. For each channel, each side associates a unique channel number, which need not be the same on both ends. Channels are flow controlled using a window mechanism. No data may be sent to a channel until a message is received to indicate that window space is available.

The life of a channel progresses through three stages: opening a channel, data transfer, and closing a channel.

When either side wishes to **open a new channel**, it allocates a local number for the channel and then sends a message of the form:

```

byte      SSH_MSG_CHANNEL_OPEN
string    channel type
uint32    sender channel
uint32    initial window size
uint32    maximum packet size
...       channel type specific data follows

```

where uint32 means unsigned 32-bit integer. The channel type identifies the application for this channel, as described subsequently. The sender channel is the local channel number. The initial window size specifies how many bytes of channel data can be sent to the sender of this message without adjusting the window. The maximum packet size specifies the maximum size of an individual data packet that can be sent to the sender. For example, one might want to use smaller packets for interactive connections to get better interactive response on slow links.

If the remote side is able to open the channel, it returns a `SSH_MSG_CHANNEL_OPEN_CONFIRMATION` message, which includes the sender channel number, the recipient channel number, and window and packet size values for incoming traffic. Otherwise, the remote side returns a `SSH_MSG_CHANNEL_OPEN_FAILURE` message with a reason code indicating the reason for failure.

Once a channel is open, **data transfer** is performed using a `SSH_MSG_CHANNEL_DATA` message, which includes the recipient channel number and a block of data. These messages, in both directions, may continue as long as the channel is open.

When either side wishes to **close a channel**, it sends a `SSH_MSG_CHANNEL_CLOSE` message, which includes the recipient channel number.

²RFC 4254, *The Secure Shell (SSH) Connection Protocol*, states that the Connection Protocol runs on top of the Transport Layer Protocol and the User Authentication Protocol. RFC 4251, *SSH Protocol Architecture*, states that the Connection Protocol runs over the User Authentication Protocol. In fact, the Connection Protocol runs over the Transport Layer Protocol, but assumes that the User Authentication Protocol has been previously invoked.

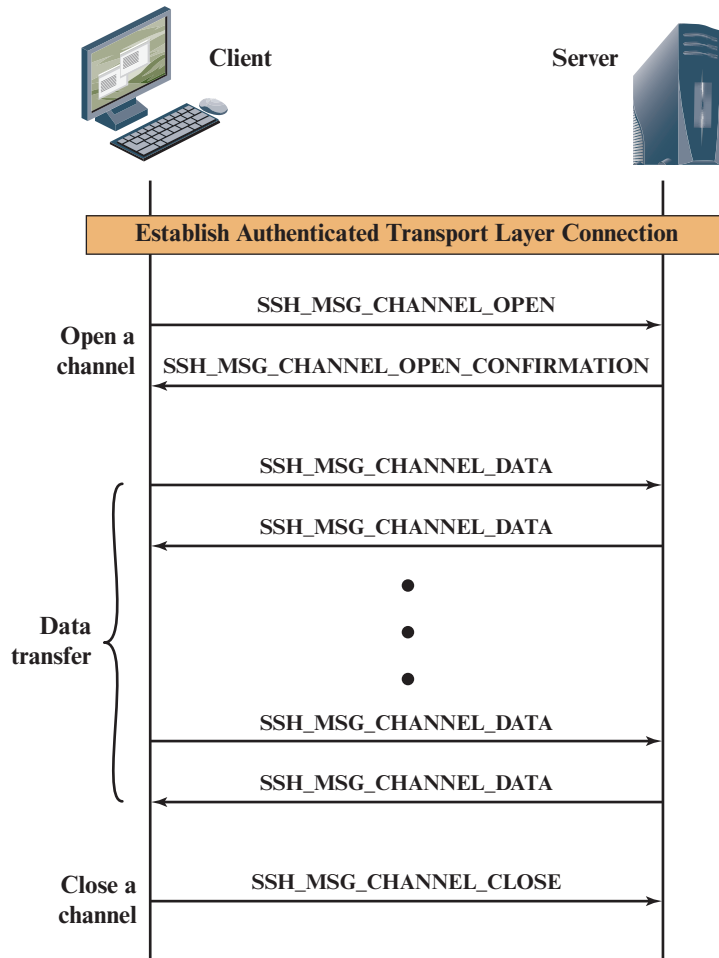

Figure 17.11 Example of SSH Connection Protocol Message Exchange

Figure 17.11 provides an example of Connection Protocol Message Exchange.

CHANNEL TYPES Four channel types are recognized in the SSH Connection Protocol specification.

- **session:** The remote execution of a program. The program may be a shell, an application such as file transfer or email, a system command, or some built-in subsystem. Once a session channel is opened, subsequent requests are used to start the remote program.
- **x11:** This refers to the X Window System, a computer software system and network protocol that provides a graphical user interface (GUI) for networked computers. X allows applications to run on a network server but to be displayed on a desktop machine.
- **forwarded-tcpip:** This is remote port forwarding, as explained in the next subsection.
- **direct-tcpip:** This is local port forwarding, as explained in the next subsection.

PORT FORWARDING One of the most useful features of SSH is port forwarding. In essence, port forwarding provides the ability to convert any insecure TCP connection into a secure SSH connection. This is also referred to as SSH tunneling. We need to know what a port is in this context. A **port** is an identifier of a user of TCP. So, any application that runs on top of TCP has a port number. Incoming TCP traffic is delivered to the appropriate application on the basis of the port number. An application may employ multiple port numbers. For example, for the Simple Mail Transfer Protocol (SMTP), the server side generally listens on port 25, so an incoming SMTP request uses TCP and addresses the data to destination port 25. TCP recognizes that this is the SMTP server address and routes the data to the SMTP server application.

Figure 17.12 illustrates the basic concept behind port forwarding. We have a client application that is identified by port number x and a server application identified by port number y . At some point, the client application invokes the local TCP entity and requests a connection to the remote server on port y . The local TCP entity

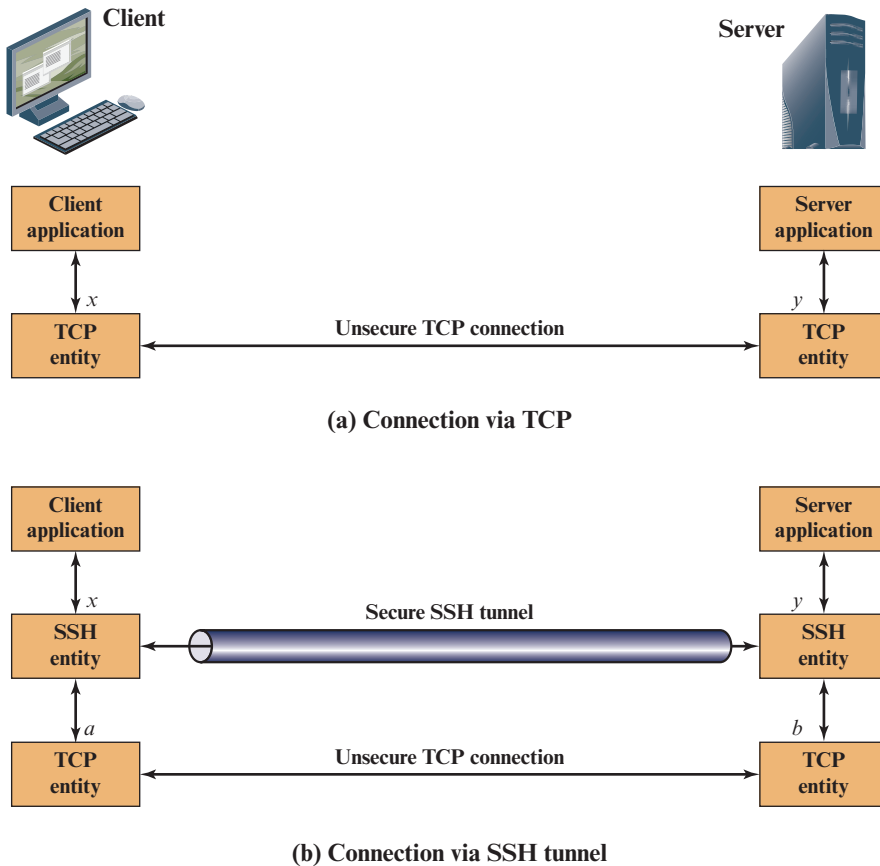

Figure 17.12 SSH Transport Layer Packet Exchanges

negotiates a TCP connection with the remote TCP entity, such that the connection links local port x to remote port y .

To secure this connection, SSH is configured so that the SSH Transport Layer Protocol establishes a TCP connection between the SSH client and server entities, with TCP port numbers a and b , respectively. A secure SSH tunnel is established over this TCP connection. Traffic from the client at port x is redirected to the local SSH entity and travels through the tunnel where the remote SSH entity delivers the data to the server application on port y . Traffic in the other direction is similarly redirected.

SSH supports two types of port forwarding: local forwarding and remote forwarding. **Local forwarding** allows the client to set up a “hijacker” process. This will intercept selected application-level traffic and redirect it from an unsecured TCP connection to a secure SSH tunnel. SSH is configured to listen on selected ports. SSH grabs all traffic using a selected port and sends it through an SSH tunnel. On the other end, the SSH server sends the incoming traffic to the destination port dictated by the client application.

The following example should help clarify local forwarding. Suppose you have an email client on your desktop and use it to get email from your mail server via the Post Office Protocol (POP). The assigned port number for POP3 is port 110. We can secure this traffic in the following way:

1. The SSH client sets up a connection to the remote server.
2. Select an unused local port number, say 9999, and configure SSH to accept traffic from this port destined for port 110 on the server.
3. The SSH client informs the SSH server to create a connection to the destination, in this case mailserver port 110.
4. The client takes any bits sent to local port 9999 and sends them to the server inside the encrypted SSH session. The SSH server decrypts the incoming bits and sends the plaintext to port 110.
5. In the other direction, the SSH server takes any bits received on port 110 and sends them inside the SSH session back to the client, who decrypts and sends them to the process connected to port 9999.

With **remote forwarding**, the user’s SSH client acts on the server’s behalf. The client receives traffic with a given destination port number, places the traffic on the correct port and sends it to the destination the user chooses. A typical example of remote forwarding is the following. You wish to access a server at work from your home computer. Because the work server is behind a firewall, it will not accept an SSH request from your home computer. However, from work you can set up an SSH tunnel using remote forwarding. This involves the following steps.

1. From the work computer, set up an SSH connection to your home computer. The firewall will allow this, because it is a protected outgoing connection.
2. Configure the SSH server to listen on a local port, say 22, and to deliver data across the SSH connection addressed to remote port, say 2222.

3. You can now go to your home computer, and configure SSH to accept traffic on port 2222.
4. You now have an SSH tunnel that can be used for remote logon to the work server.

17.5 REVIEW QUESTIONS AND PROBLEMS

Review Questions

- 17.1 What are the advantages of each of the three approaches shown in Figure 17.1?
- 17.2 What protocols comprise TLS?
- 17.3 What is the difference between a TLS connection and a TLS session?
- 17.4 List and briefly define the parameters that define a TLS session state.
- 17.5 List and briefly define the parameters that define a TLS session connection.
- 17.6 What services are provided by the TLS Record Protocol?
- 17.7 What steps are involved in the TLS Record Protocol transmission?
- 17.8 Briefly discuss the different levels of awareness of a connection in HTTPS.
- 17.9 Which protocol was replaced by SSH and why? Which version is currently in the process of being standardized?
- 17.10 List and briefly define the SSH protocols.

Problems

- 17.1 In SSL and TLS, why is there a separate Change Cipher Spec Protocol rather than including a `change_cipher_spec` message in the Handshake Protocol?
- 17.2 What purpose does the MAC serve during the change cipher spec TLS exchange?
- 17.3 Consider the following threats to Web security and describe how each is countered by a particular feature of TLS.
 - a. Brute-Force Cryptanalytic Attack: An exhaustive search of the key space for a conventional encryption algorithm.
 - b. Known Plaintext Dictionary Attack: Many messages will contain predictable plaintext, such as the HTTP GET command. An attacker constructs a dictionary containing every possible encryption of the known-plaintext message. When an encrypted message is intercepted, the attacker takes the portion containing the encrypted known plaintext and looks up the ciphertext in the dictionary. The ciphertext should match against an entry that was encrypted with the same secret key. If there are several matches, each of these can be tried against the full ciphertext to determine the right one. This attack is especially effective against small key sizes (e.g., 40-bit keys).
 - c. Replay Attack: Earlier TLS handshake messages are replayed.
 - d. Man-in-the-Middle Attack: An attacker interposes during key exchange, acting as the client to the server and as the server to the client.
 - e. Password Sniffing: Passwords in HTTP or other application traffic are eavesdropped.
 - f. IP Spoofing: Uses forged IP addresses to fool a host into accepting bogus data.
 - g. IP Hijacking: An active, authenticated connection between two hosts is disrupted and the attacker takes the place of one of the hosts.

- h.** SYN Flooding: An attacker sends TCP SYN messages to request a connection but does not respond to the final message to establish the connection fully. The attacked TCP module typically leaves the “half-open connection” around for a few minutes. Repeated SYN messages can clog the TCP module.
- 17.4** Based on what you have learned in this chapter, is it possible in TLS for the receiver to reorder TLS record blocks that arrive out of order? If so, explain how it can be done. If not, why not?
- 17.5** For SSH packets, what is the advantage, if any, of not including the MAC in the scope of the packet encryption?

CHAPTER 18

WIRELESS NETWORK SECURITY

18.1 Wireless Security

- Wireless Network Threats
- Wireless Security Measures

18.2 Mobile Device Security

- Security Threats
- Mobile Device Security Strategy

18.3 IEEE 802.11 Wireless LAN Overview

- The Wi-Fi Alliance
- IEEE 802 Protocol Architecture
- IEEE 802.11 Network Components and Architectural Model
- IEEE 802.11 Services

18.4 IEEE 802.11i Wireless LAN Security

- IEEE 802.11i Services
- IEEE 802.11i Phases of Operation
 - Discovery Phase
 - Authentication Phase
 - Key Management Phase
 - Protected Data Transfer Phase
- The IEEE 802.11i Pseudorandom Function

18.5 Key Terms, Review Questions, and Problems

LEARNING OBJECTIVES

After studying this chapter, you should be able to:

- ◆ Present an overview of security threats and countermeasures for wireless networks.
- ◆ Understand the unique security threats posed by the use of mobile devices with enterprise networks.
- ◆ Describe the principal elements in a mobile device security strategy.
- ◆ Understand the essential elements of the IEEE 802.11 wireless LAN standard.
- ◆ Summarize the various components of the IEEE 802.11i wireless LAN security architecture.

This chapter begins with a general overview of wireless security issues. We then focus on the relatively new area of mobile device security, examining threats and countermeasures for mobile devices used in the enterprise. Then, we look at the IEEE 802.11i standard for wireless LAN security. This standard is part of IEEE 802.11, also referred to as Wi-Fi. We begin the discussion with an overview of IEEE 802.11, and then we look in some detail at IEEE 802.11i.

18.1 WIRELESS SECURITY

Wireless networks, and the wireless devices that use them, introduce a host of security problems over and above those found in wired networks. Some of the key factors contributing to the higher security risk of wireless networks compared to wired networks include the following [MA10]:

- **Channel:** Wireless networking typically involves broadcast communications, which is far more susceptible to eavesdropping and jamming than wired networks. Wireless networks are also more vulnerable to active attacks that exploit vulnerabilities in communications protocols.
- **Mobility:** Wireless devices are, in principal and usually in practice, far more portable and mobile than wired devices. This mobility results in a number of risks, described subsequently.
- **Resources:** Some wireless devices, such as smartphones and tablets, have sophisticated operating systems but limited memory and processing resources with which to counter threats, including denial of service and malware.
- **Accessibility:** Some wireless devices, such as sensors and robots, may be left unattended in remote and/or hostile locations. This greatly increases their vulnerability to physical attacks.

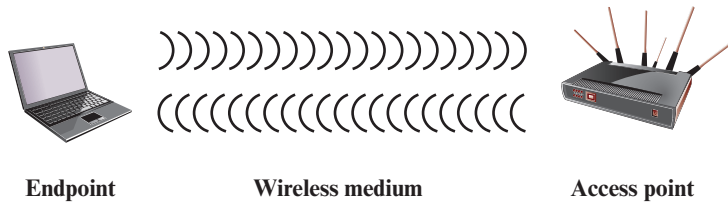

Figure 18.1 Wireless Networking Components

In simple terms, the wireless environment consists of three components that provide point of attack (Figure 18.1). The wireless client can be a cell phone, a Wi-Fi-enabled laptop or tablet, a wireless sensor, a Bluetooth device, and so on. The wireless access point provides a connection to the network or service. Examples of access points are cell towers, Wi-Fi hotspots, and wireless access points to wired local or wide area networks. The transmission medium, which carries the radio waves for data transfer, is also a source of vulnerability.

Wireless Network Threats

[CHOI08] lists the following security threats to wireless networks:

- **Accidental association:** Company wireless LANs or wireless access points to wired LANs in close proximity (e.g., in the same or neighboring buildings) may create overlapping transmission ranges. A user intending to connect to one LAN may unintentionally lock on to a wireless access point from a neighboring network. Although the security breach is accidental, it nevertheless exposes resources of one LAN to the accidental user.
- **Malicious association:** In this situation, a wireless device is configured to appear to be a legitimate access point, enabling the operator to steal passwords from legitimate users and then penetrate a wired network through a legitimate wireless access point.
- **Ad hoc networks:** These are peer-to-peer networks between wireless computers with no access point between them. Such networks can pose a security threat due to a lack of a central point of control.
- **Nontraditional networks:** Nontraditional networks and links, such as personal network Bluetooth devices, barcode readers, and handheld PDAs, pose a security risk in terms of both eavesdropping and spoofing.
- **Identity theft (MAC spoofing):** This occurs when an attacker is able to eavesdrop on network traffic and identify the MAC address of a computer with network privileges.
- **Man-in-the middle attacks:** This type of attack is described in Chapter 10 in the context of the Diffie–Hellman key exchange protocol. In a broader sense, this attack involves persuading a user and an access point to believe that they are talking to each other when in fact the communication is going through an intermediate attacking device. Wireless networks are particularly vulnerable to such attacks.

- **Denial of service (DoS):** This type of attack is discussed in detail in Chapter 21. In the context of a wireless network, a DoS attack occurs when an attacker continually bombards a wireless access point or some other accessible wireless port with various protocol messages designed to consume system resources. The wireless environment lends itself to this type of attack, because it is so easy for the attacker to direct multiple wireless messages at the target.
- **Network injection:** A network injection attack targets wireless access points that are exposed to nonfiltered network traffic, such as routing protocol messages or network management messages. An example of such an attack is one in which bogus reconfiguration commands are used to affect routers and switches to degrade network performance.

Wireless Security Measures

Following [CHOI08], we can group wireless security measures into those dealing with wireless transmissions, wireless access points, and wireless networks (consisting of wireless routers and endpoints).

SECURING WIRELESS TRANSMISSIONS The principal threats to wireless transmission are eavesdropping, altering or inserting messages, and disruption. To deal with eavesdropping, two types of countermeasures are appropriate:

- **Signal-hiding techniques:** Organizations can take a number of measures to make it more difficult for an attacker to locate their wireless access points, including turning off service set identifier (SSID) broadcasting by wireless access points; assigning cryptic names to SSIDs; reducing signal strength to the lowest level that still provides requisite coverage; and locating wireless access points in the interior of the building, away from windows and exterior walls. Greater security can be achieved by the use of directional antennas and of signal-shielding techniques.
- **Encryption:** Encryption of all wireless transmission is effective against eavesdropping to the extent that the encryption keys are secured.

The use of encryption and authentication protocols is the standard method of countering attempts to alter or insert transmissions.

The methods discussed in Chapter 21 for dealing with DoS apply to wireless transmissions. Organizations can also reduce the risk of unintentional DoS attacks. Site surveys can detect the existence of other devices using the same frequency range, to help determine where to locate wireless access points. Signal strengths can be adjusted and shielding used in an attempt to isolate a wireless environment from competing nearby transmissions.

SECURING WIRELESS ACCESS POINTS The main threat involving wireless access points is unauthorized access to the network. The principal approach for preventing such access is the IEEE 802.1X standard for port-based network access control. The standard provides an authentication mechanism for devices wishing to attach to a LAN or wireless network. The use of 802.1X can prevent rogue access points and other unauthorized devices from becoming insecure backdoors.

Section 16.3 provides an introduction to 802.1X.

SECURING WIRELESS NETWORKS [CHOI08] recommends the following techniques for wireless network security:

1. Use encryption. Wireless routers are typically equipped with built-in encryption mechanisms for router-to-router traffic.
2. Use antivirus and antispyware software, and a firewall. These facilities should be enabled on all wireless network endpoints.
3. Turn off identifier broadcasting. Wireless routers are typically configured to broadcast an identifying signal so that any device within range can learn of the router's existence. If a network is configured so that authorized devices know the identity of routers, this capability can be disabled, so as to thwart attackers.
4. Change the identifier on your router from the default. Again, this measure thwarts attackers who will attempt to gain access to a wireless network using default router identifiers.
5. Change your router's pre-set password for administration. This is another prudent step.
6. Allow only specific computers to access your wireless network. A router can be configured to only communicate with approved MAC addresses. Of course, MAC addresses can be spoofed, so this is just one element of a security strategy.

18.2 MOBILE DEVICE SECURITY

Prior to the widespread use of smartphones, the dominant paradigm for computer and network security in organizations was as follows. Corporate IT was tightly controlled. User devices were typically limited to Windows PCs. Business applications were controlled by IT and either run locally on endpoints or on physical servers in data centers. Network security was based upon clearly defined perimeters that separated trusted internal networks from the untrusted Internet. Since then, there have been massive changes in each of these assumptions. An organization's networks must accommodate the following:

- **Growing use of new devices:** Organizations are experiencing significant growth in employee use of mobile devices. In many cases, employees are allowed to use a combination of endpoint devices as part of their day-to-day activities.
- **Cloud-based applications:** Applications no longer run solely on physical servers in corporate data centers. Quite the opposite, applications can run anywhere—on traditional physical servers, on mobile virtual servers, or in the cloud. Additionally, end users can now take advantage of a wide variety of cloud-based applications and IT services for personal and professional use. Facebook can be used for an employee's personal profiles or as a component of a corporate marketing campaign. Employees depend upon Skype to speak with friends abroad or for legitimate business video conferencing. Dropbox and Box can be used to distribute documents between corporate and personal devices for mobility and user productivity.

- **De-perimeterization:** Given new device proliferation, application mobility, and cloud-based consumer and corporate services, the notion of a static network perimeter is all but gone. Now there are a multitude of network perimeters around devices, applications, users, and data. These perimeters have also become quite dynamic as they must adapt to various environmental conditions such as user role, device type, server virtualization mobility, network location, and time-of-day.
- **External business requirements:** The enterprise must also provide guests, third-party contractors, and business partners network access using various devices from a multitude of locations.

The central element in all of these changes is the mobile computing device. Mobile devices have become an essential element for organizations as part of the overall network infrastructure. Mobile devices such as smartphones, tablets, and memory sticks provide increased convenience for individuals as well as the potential for increased productivity in the workplace. Because of their widespread use and unique characteristics, security for mobile devices is a pressing and complex issue. In essence, an organization needs to implement a security policy through a combination of security features built into the mobile devices and additional security controls provided by network components that regulate the use of the mobile devices.

Security Threats

Mobile devices need additional, specialized protection measures beyond those implemented for other client devices, such as desktop and laptop devices that are used only within the organization's facilities and on the organization's networks. SP 800-14 (*Guidelines for Managing and Securing Mobile Devices in the Enterprise*, July 2012) lists seven major security concerns for mobile devices. We examine each of these in turn.

LACK OF PHYSICAL SECURITY CONTROLS Mobile devices are typically under the complete control of the user, and are used and kept in a variety of locations outside the organization's control, including off premises. Even if a device is required to remain on premises, the user may move the device within the organization between secure and nonsecured locations. Thus, theft and tampering are realistic threats.

The security policy for mobile devices must be based on the assumption that any mobile device may be stolen or at least accessed by a malicious party. The threat is twofold: A malicious party may attempt to recover sensitive data from the device itself, or may use the device to gain access to the organization's resources.

USE OF UNTRUSTED MOBILE DEVICES In addition to company-issued and company-controlled mobile devices, virtually all employees will have personal smartphones and/or tablets. The organization must assume that these devices are not trustworthy. That is, the devices may not employ encryption and either the user or a third party may have installed a bypass to the built-in restrictions on security, operating system use, and so on.

USE OF UNTRUSTED NETWORKS If a mobile device is used on premises, it can connect to organization resources over the organization's own in-house wireless networks. However, for off-premises use, the user will typically access organizational resources via Wi-Fi or cellular access to the Internet and from the Internet to the organization. Thus, traffic that includes an off-premises segment is potentially susceptible to eavesdropping or man-in-the-middle types of attacks. Thus, the security policy must be based on the assumption that the networks between the mobile device and the organization are not trustworthy.

USE OF APPLICATIONS CREATED BY UNKNOWN PARTIES By design, it is easy to find and install third-party applications on mobile devices. This poses the obvious risk of installing malicious software. An organization has several options for dealing with this threat, as described subsequently.

INTERACTION WITH OTHER SYSTEMS A common feature found on smartphones and tablets is the ability to automatically synchronize data, apps, contacts, photos, and so on with other computing devices and with cloud-based storage. Unless an organization has control of all the devices involved in synchronization, there is considerable risk of the organization's data being stored in an unsecured location, plus the risk of the introduction of malware.

USE OF UNTRUSTED CONTENT Mobile devices may access and use content that other computing devices do not encounter. An example is the Quick Response (QR) code, which is a two-dimensional barcode. QR codes are designed to be captured by a mobile device camera and used by the mobile device. The QR code translates to a URL, so that a malicious QR code could direct the mobile device to malicious Web sites.

USE OF LOCATION SERVICES The GPS capability on mobile devices can be used to maintain a knowledge of the physical location of the device. While this feature might be useful to an organization as part of a presence service, it creates security risks. An attacker can use the location information to determine where the device and user are located, which may be of use to the attacker.

Mobile Device Security Strategy

With the threats listed in the preceding discussion in mind, we outline the principal elements of a mobile device security strategy. They fall into three categories: device security, client/server traffic security, and barrier security (Figure 18.2).

DEVICE SECURITY A number of organizations will supply mobile devices for employee use and preconfigure those devices to conform to the enterprise security policy. However, many organizations will find it convenient or even necessary to adopt a bring-your-own-device (BYOD) policy that allows the personal mobile devices of employees to have access to corporate resources. IT managers should be able to inspect each device before allowing network access. IT will want to establish configuration guidelines for operating systems and applications. For example, "rooted" or "jail-broken" devices are not permitted on the network, and mobile

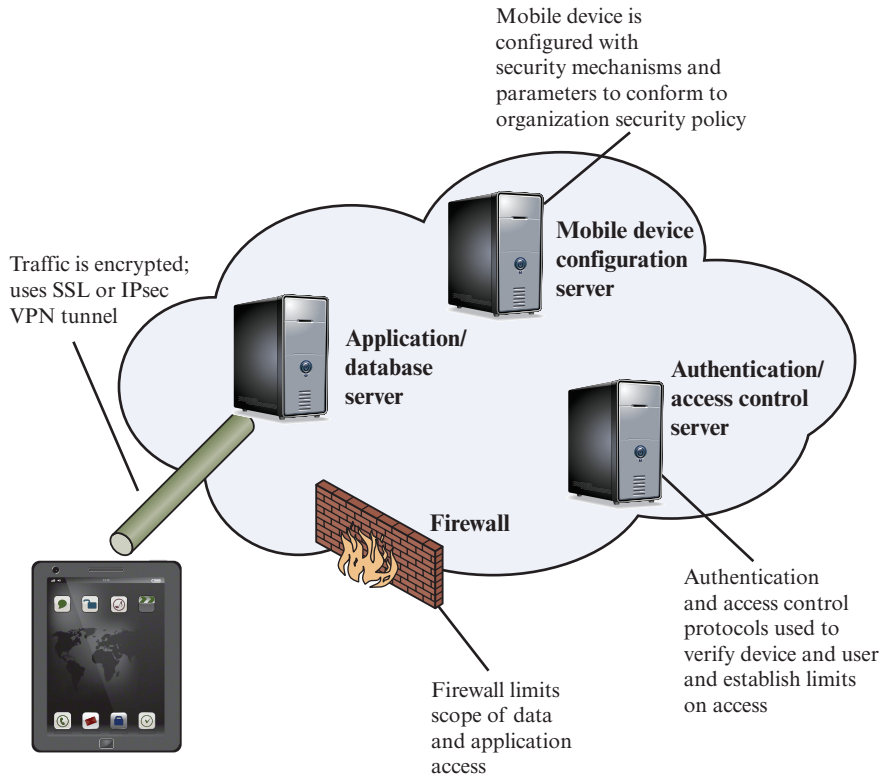

Figure 18.2 Mobile Device Security Elements

devices cannot store corporate contacts on local storage. Whether a device is owned by the organization or BYOD, the organization should configure the device with security controls, including the following:

- Enable auto-lock, which causes the device to lock if it has not been used for a given amount of time, requiring the user to re-enter a four-digit PIN or a password to re-activate the device.
- Enable password or PIN protection. The PIN or password is needed to unlock the device. In addition, it can be configured so that email and other data on the device are encrypted using the PIN or password and can only be retrieved with the PIN or password.
- Avoid using auto-complete features that remember user names or passwords.
- Enable remote wipe.
- Ensure that SSL protection is enabled, if available.
- Make sure that software, including operating systems and applications, is up to date.
- Install antivirus software as it becomes available.

- Either sensitive data should be prohibited from storage on the mobile device or it should be encrypted.
- IT staff should also have the ability to remotely access devices, wipe the device of all data, and then disable the device in the event of loss or theft.
- The organization may prohibit all installation of third-party applications, implement whitelisting to prohibit installation of all unapproved applications, or implement a secure sandbox that isolates the organization's data and applications from all other data and applications on the mobile device. Any application that is on an approved list should be accompanied by a digital signature and a public-key certificate from an approved authority.
- The organization can implement and enforce restrictions on what devices can synchronize and on the use of cloud-based storage.
- To deal with the threat of untrusted content, security responses can include training of personnel on the risks inherent in untrusted content and disabling camera use on corporate mobile devices.
- To counter the threat of malicious use of location services, the security policy can dictate that such service is disabled on all mobile devices.

TRAFFIC SECURITY Traffic security is based on the usual mechanisms for encryption and authentication. All traffic should be encrypted and travel by secure means, such as SSL or IPv6. Virtual private networks (VPNs) can be configured so that all traffic between the mobile device and the organization's network is via a VPN.

A strong authentication protocol should be used to limit the access from the device to the resources of the organization. Often, a mobile device has a single device-specific authenticator, because it is assumed that the device has only one user. A preferable strategy is to have a two-layer authentication mechanism, which involves authenticating the device and then authenticating the user of the device.

BARRIER SECURITY The organization should have security mechanisms to protect the network from unauthorized access. The security strategy can also include firewall policies specific to mobile device traffic. Firewall policies can limit the scope of data and application access for all mobile devices. Similarly, intrusion detection and intrusion prevention systems can be configured to have tighter rules for mobile device traffic.

18.3 IEEE 802.11 WIRELESS LAN OVERVIEW

IEEE 802 is a committee that has developed standards for a wide range of local area networks (LANs). In 1990, the IEEE 802 Committee formed a new working group, **IEEE 802.11**, with a charter to develop a protocol and transmission specifications for wireless LANs (WLANs). Since that time, the demand for WLANs at different frequencies and data rates has exploded. Keeping pace with this demand, the IEEE 802.11 working group has issued an ever-expanding list of standards. Table 18.1 briefly defines key terms used in the IEEE 802.11 standard.

Table 18.1 IEEE 802.11 Terminology

Access point (AP)	Any entity that has station functionality and provides access to the distribution system via the wireless medium for associated stations.
Basic service set (BSS)	A set of stations controlled by a single coordination function.
Coordination function	The logical function that determines when a station operating within a BSS is permitted to transmit and may be able to receive PDUs.
Distribution system (DS)	A system used to interconnect a set of BSSs and integrated LANs to create an ESS.
Extended service set (ESS)	A set of one or more interconnected BSSs and integrated LANs that appear as a single BSS to the LLC layer at any station associated with one of these BSSs.
MAC protocol data unit (MPDU)	The unit of data exchanged between two peer MAC entities using the services of the physical layer.
MAC service data unit (MSDU)	Information that is delivered as a unit between MAC users.
Station	Any device that contains an IEEE 802.11 conformant MAC and physical layer.

The Wi-Fi Alliance

The first 802.11 standard to gain broad industry acceptance was 802.11b. Although 802.11b products are all based on the same standard, there is always a concern whether products from different vendors will successfully interoperate. To meet this concern, the Wireless Ethernet Compatibility Alliance (WECA), an industry consortium, was formed in 1999. This organization, subsequently renamed the Wi-Fi (Wireless Fidelity) Alliance, created a test suite to certify interoperability for 802.11b products. The term used for certified 802.11b products is *Wi-Fi*. Wi-Fi certification has been extended to 802.11g products. The Wi-Fi Alliance has also developed a certification process for 802.11a products, called *Wi-Fi5*. The Wi-Fi Alliance is concerned with a range of market areas for WLANs, including enterprise, home, and hot spots.

More recently, the Wi-Fi Alliance has developed certification procedures for IEEE 802.11 security standards, referred to as Wi-Fi Protected Access (WPA). The most recent version of WPA, known as WPA2, incorporates all of the features of the IEEE 802.11i WLAN security specification.

IEEE 802 Protocol Architecture

Before proceeding, we need to briefly preview the IEEE 802 protocol architecture. IEEE 802.11 standards are defined within the structure of a layered set of protocols. This structure, used for all IEEE 802 standards, is illustrated in Figure 18.3.

PHYSICAL LAYER The lowest layer of the IEEE 802 reference model is the **physical layer**, which includes such functions as encoding/decoding of signals and bit transmission/reception. In addition, the physical layer includes a specification of the transmission medium. In the case of IEEE 802.11, the physical layer also defines frequency bands and antenna characteristics.

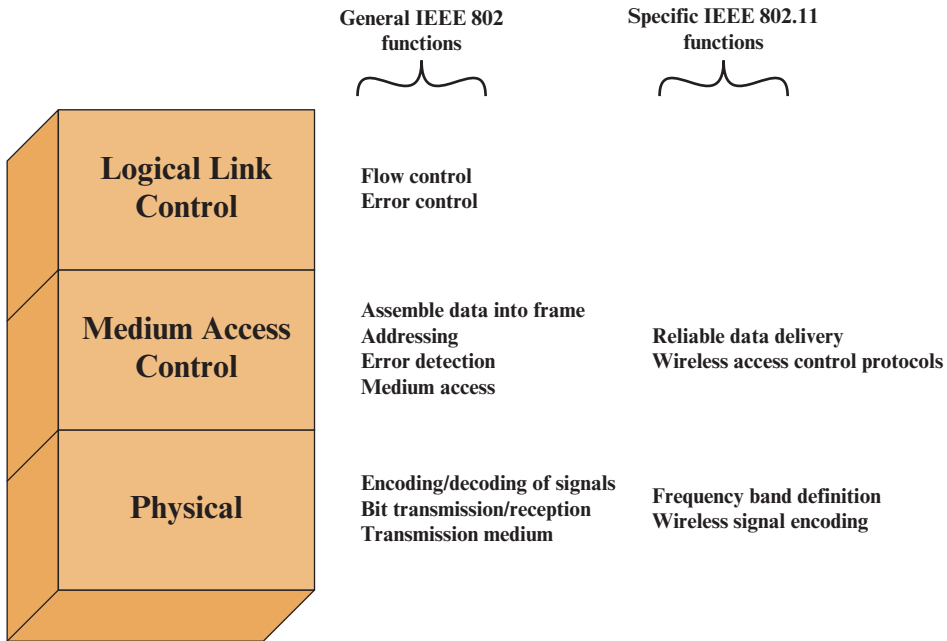

Figure 18.3 IEEE 802.11 Protocol Stack

MEDIA ACCESS CONTROL All LANs consist of collections of devices that share the network's transmission capacity. Some means of controlling access to the transmission medium is needed to provide an orderly and efficient use of that capacity. This is the function of a **media access control (MAC)** layer. The MAC layer receives data from a higher-layer protocol, typically the Logical Link Control (LLC) layer, in the form of a block of data known as the MAC service data unit (MSDU). In general, the MAC layer performs the following functions:

- On transmission, assemble data into a frame, known as a MAC protocol data unit (MPDU) with address and error-detection fields.
- On reception, disassemble frame, and perform address recognition and error detection.
- Govern access to the LAN transmission medium.

The exact format of the MPDU differs somewhat for the various MAC protocols in use. In general, all of the MPDUs have a format similar to that of Figure 18.4. The fields of this frame are as follows.

- **MAC Control:** This field contains any protocol control information needed for the functioning of the MAC protocol. For example, a priority level could be indicated here.
- **Destination MAC Address:** The destination physical address on the LAN for this MPDU.
- **Source MAC Address:** The source physical address on the LAN for this MPDU.

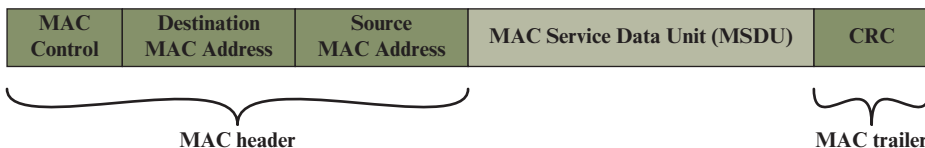

Figure 18.4 General IEEE 802 MPDU Format

- **MAC Service Data Unit:** The data from the next higher layer.
- **CRC:** The cyclic redundancy check field; also known as the Frame Check Sequence (FCS) field. This is an error-detecting code, such as that which is used in other data-link control protocols. The CRC is calculated based on the bits in the entire MPDU. The sender calculates the CRC and adds it to the frame. The receiver performs the same calculation on the incoming MPDU and compares that calculation to the CRC field in that incoming MPDU. If the two values don't match, then one or more bits have been altered in transit.

The fields preceding the MSDU field are referred to as the **MAC header**, and the field following the MSDU field is referred to as the **MAC trailer**. The header and trailer contain control information that accompany the data field and that are used by the MAC protocol.

LOGICAL LINK CONTROL In most data-link control protocols, the data-link protocol entity is responsible not only for detecting errors using the CRC, but for recovering from those errors by retransmitting damaged frames. In the LAN protocol architecture, these two functions are split between the MAC and LLC layers. The MAC layer is responsible for detecting errors and discarding any frames that contain errors. The LLC layer optionally keeps track of which frames have been successfully received and retransmits unsuccessful frames.

IEEE 802.11 Network Components and Architectural Model

Figure 18.5 illustrates the model developed by the 802.11 working group. The smallest building block of a wireless LAN is a basic service set (BSS), which consists of wireless stations executing the same MAC protocol and competing for access to the same shared wireless medium. A BSS may be isolated, or it may connect to a backbone distribution system (DS) through an access point (AP). The AP functions as a bridge and a relay point. In a BSS, client stations do not communicate directly with one another. Rather, if one station in the BSS wants to communicate with another station in the same BSS, the MAC frame is first sent from the originating station to the AP and then from the AP to the destination station. Similarly, a MAC frame from a station in the BSS to a remote station is sent from the local station to the AP and then relayed by the AP over the DS on its way to the destination station. The BSS generally corresponds to what is referred to as a cell in the literature. The DS can be a switch, a wired network, or a wireless network.

When all the stations in the BSS are mobile stations that communicate directly with one another (not using an AP), the BSS is called an independent BSS (IBSS). An IBSS is typically an ad hoc network. In an IBSS, the stations all communicate directly, and no AP is involved.

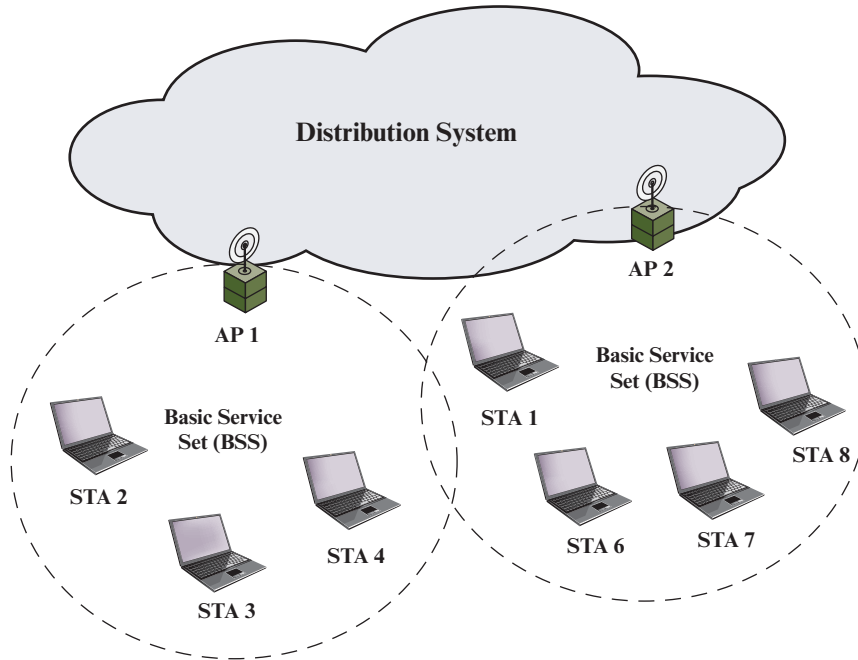

Figure 18.5 IEEE 802.11 Extended Service Set

A simple configuration is shown in Figure 18.5, in which each station belongs to a single BSS; that is, each station is within wireless range only of other stations within the same BSS. It is also possible for two BSSs to overlap geographically, so that a single station could participate in more than one BSS. Furthermore, the association between a station and a BSS is dynamic. Stations may turn off, come within range, and go out of range.

An extended service set (ESS) consists of two or more basic service sets interconnected by a distribution system. The extended service set appears as a single logical LAN to the logical link control (LLC) level.

IEEE 802.11 Services

IEEE 802.11 defines nine services that need to be provided by the wireless LAN to achieve functionality equivalent to that which is inherent to wired LANs. Table 18.2 lists the services and indicates two ways of categorizing them.

1. The service provider can be either the station or the DS. Station services are implemented in every 802.11 station, including AP stations. Distribution services are provided between BSSs; these services may be implemented in an AP or in another special-purpose device attached to the distribution system.
2. Three of the services are used to control IEEE 802.11 LAN access and confidentiality. Six of the services are used to support delivery of MSDUs between stations. If the MSDU is too large to be transmitted in a single MPDU, it may be fragmented and transmitted in a series of MPDUs.

Table 18.2 IEEE 802.11 Services

Service	Provider	Used to support
Association	Distribution system	MSDU delivery
Authentication	Station	LAN access and security
Deauthentication	Station	LAN access and security
Disassociation	Distribution system	MSDU delivery
Distribution	Distribution system	MSDU delivery
Integration	Distribution system	MSDU delivery
MSDU delivery	Station	MSDU delivery
Privacy	Station	LAN access and security
Reassociation	Distribution system	MSDU delivery

Following the IEEE 802.11 document, we next discuss the services in an order designed to clarify the operation of an IEEE 802.11 ESS network. **MSDU delivery**, which is the basic service, already has been mentioned. Services related to security are introduced in Section 18.4.

DISTRIBUTION OF MESSAGES WITHIN A DS The two services involved with the distribution of messages within a DS are distribution and integration. **Distribution** is the primary service used by stations to exchange MPDUs when the MPDUs must traverse the DS to get from a station in one BSS to a station in another BSS. For example, suppose a frame is to be sent from station 2 (STA 2) to station 7 (STA 7) in Figure 18.5. The frame is sent from STA 2 to AP 1, which is the AP for this BSS. The AP gives the frame to the DS, which has the job of directing the frame to the AP associated with STA 7 in the target BSS. AP 2 receives the frame and forwards it to STA 7. How the message is transported through the DS is beyond the scope of the IEEE 802.11 standard.

If the two stations that are communicating are within the same BSS, then the distribution service logically goes through the single AP of that BSS.

The **integration** service enables transfer of data between a station on an IEEE 802.11 LAN and a station on an integrated IEEE 802.x LAN. The term *integrated* refers to a wired LAN that is physically connected to the DS and whose stations may be logically connected to an IEEE 802.11 LAN via the integration service. The integration service takes care of any address translation and media conversion logic required for the exchange of data.

ASSOCIATION-RELATED SERVICES The primary purpose of the MAC layer is to transfer MSDUs between MAC entities; this purpose is fulfilled by the distribution service. For that service to function, it requires information about stations within the ESS that is provided by the association-related services. Before the distribution service can deliver data to or accept data from a station, that station must be *associated*. Before looking at the concept of association, we need

to describe the concept of mobility. The standard defines three transition types, based on mobility:

- **No transition:** A station of this type is either stationary or moves only within the direct communication range of the communicating stations of a single BSS.
- **BSS transition:** This is defined as a station movement from one BSS to another BSS within the same ESS. In this case, delivery of data to the station requires that the addressing capability be able to recognize the new location of the station.
- **ESS transition:** This is defined as a station movement from a BSS in one ESS to a BSS within another ESS. This case is supported only in the sense that the station can move. Maintenance of upper-layer connections supported by 802.11 cannot be guaranteed. In fact, disruption of service is likely to occur.

To deliver a message within a DS, the distribution service needs to know where the destination station is located. Specifically, the DS needs to know the identity of the AP to which the message should be delivered in order for that message to reach the destination station. To meet this requirement, a station must maintain an association with the AP within its current BSS. Three services relate to this requirement:

- **Association:** Establishes an initial association between a station and an AP. Before a station can transmit or receive frames on a wireless LAN, its identity and address must be known. For this purpose, a station must establish an association with an AP within a particular BSS. The AP can then communicate this information to other APs within the ESS to facilitate routing and delivery of addressed frames.
- **Reassociation:** Enables an established association to be transferred from one AP to another, allowing a mobile station to move from one BSS to another.
- **Disassociation:** A notification from either a station or an AP that an existing association is terminated. A station should give this notification before leaving an ESS or shutting down. However, the MAC management facility protects itself against stations that disappear without notification.

18.4 IEEE 802.11i WIRELESS LAN SECURITY

There are two characteristics of a wired LAN that are not inherent in a wireless LAN.

1. In order to transmit over a wired LAN, a station must be physically connected to the LAN. On the other hand, with a wireless LAN, any station within radio range of the other devices on the LAN can transmit. In a sense, there is a form of authentication with a wired LAN in that it requires some positive and presumably observable action to connect a station to a wired LAN.
2. Similarly, in order to receive a transmission from a station that is part of a wired LAN, the receiving station also must be attached to the wired LAN. On the other hand, with a wireless LAN, any station within radio range can receive. Thus, a wired LAN provides a degree of privacy, limiting reception of data to stations connected to the LAN.

These differences between wired and wireless LANs suggest the increased need for robust security services and mechanisms for wireless LANs. The original 802.11 specification included a set of security features for privacy and authentication that were quite weak. For privacy, 802.11 defined the Wired Equivalent Privacy (WEP) algorithm. The privacy portion of the 802.11 standard contained major weaknesses. Subsequent to the development of WEP, the 802.11i task group has developed a set of capabilities to address the WLAN security issues. In order to accelerate the introduction of strong security into WLANs, the Wi-Fi Alliance promulgated Wi-Fi Protected Access (WPA) as a Wi-Fi standard. WPA is a set of security mechanisms that eliminates most 802.11 security issues and was based on the current state of the 802.11i standard. The final form of the 802.11i standard is referred to as Robust Security Network (RSN). The Wi-Fi Alliance certifies vendors in compliance with the full 802.11i specification under the WPA2 program.

The RSN specification is quite complex, and occupies 145 pages of the 2012 IEEE 802.11 standard. In this section, we provide an overview.

IEEE 802.11i Services

The 802.11i RSN security specification defines the following services.

- **Authentication:** A protocol is used to define an exchange between a user and an AS that provides mutual authentication and generates temporary keys to be used between the client and the AP over the wireless link.
- **Access control:**¹ This function enforces the use of the authentication function, routes the messages properly, and facilitates key exchange. It can work with a variety of authentication protocols.
- **Privacy with message integrity:** MAC-level data (e.g., an LLC PDU) are encrypted along with a message integrity code that ensures that the data have not been altered.

Figure 18.6a indicates the security protocols used to support these services, while Figure 18.6b lists the cryptographic algorithms used for these services.

IEEE 802.11i Phases of Operation

The operation of an IEEE 802.11i RSN can be broken down into five distinct phases of operation. The exact nature of the phases will depend on the configuration and the end points of the communication. Possibilities include (see Figure 18.5):

1. Two wireless stations in the same BSS communicating via the access point (AP) for that BSS.
2. Two wireless stations (STAs) in the same ad hoc IBSS communicating directly with each other.

¹In this context, we are discussing access control as a security function. This is a different function than media access control (MAC) as described in Section 18.3. Unfortunately, the literature and the standards use the term *access control* in both contexts.

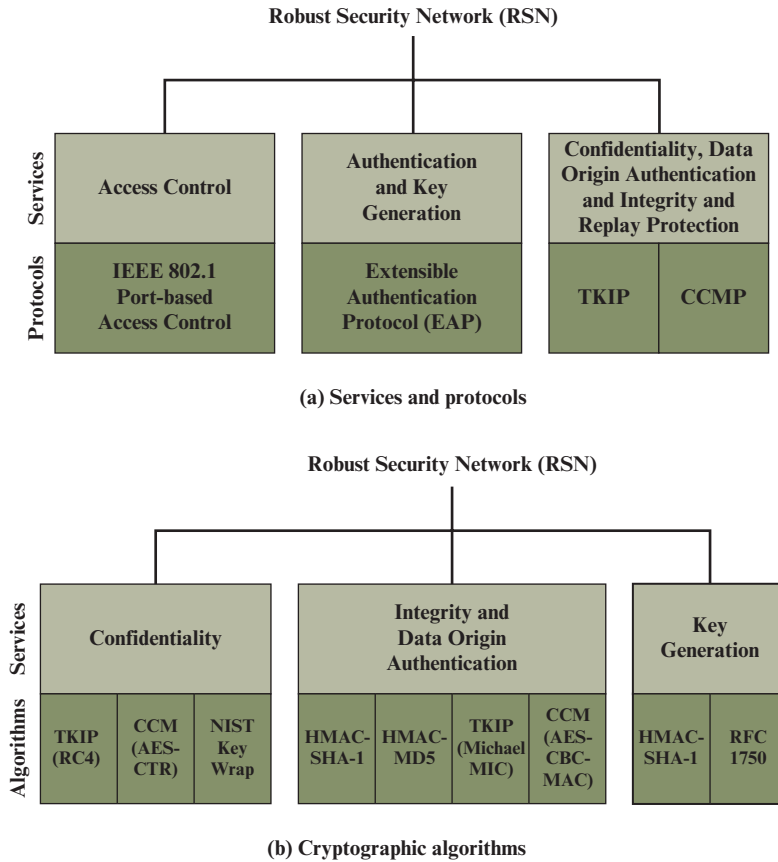

- CBC-MAC = Cipher Block Chaining Message Authentication Code (MAC)
- CCM = Counter Mode with Cipher Block Chaining Message Authentication Code
- CCMP = Counter Mode with Cipher Block Chaining MAC Protocol
- TKIP = Temporal Key Integrity Protocol

Figure 18.6 Elements of IEEE 802.11i

3. Two wireless stations in different BSSs communicating via their respective APs across a distribution system.
4. A wireless station communicating with an end station on a wired network via its AP and the distribution system.

IEEE 802.11i security is concerned only with secure communication between the STA and its AP. In case 1 in the preceding list, secure communication is assured if each STA establishes secure communications with the AP. Case 2 is similar, with the AP functionality residing in the STA. For case 3, security is not provided across the distribution system at the level of IEEE 802.11, but only within each BSS. End-to-end security (if required) must be provided at a higher layer. Similarly, in case 4, security is only provided between the STA and its AP.

With these considerations in mind, Figure 18.7 depicts the five phases of operation for an RSN and maps them to the network components involved. One new component is the authentication server (AS). The rectangles indicate the exchange of sequences of MPDUs. The five phases are defined as follows.

- **Discovery:** An AP uses messages called Beacons and Probe Responses to advertise its IEEE 802.11i security policy. The STA uses these to identify an AP for a WLAN with which it wishes to communicate. The STA associates with the AP, which it uses to select the cipher suite and authentication mechanism when the Beacons and Probe Responses present a choice.
- **Authentication:** During this phase, the STA and AS prove their identities to each other. The AP blocks non-authentication traffic between the STA and AS until the authentication transaction is successful. The AP does not participate in the authentication transaction other than forwarding traffic between the STA and AS.
- **Key generation and distribution:** The AP and the STA perform several operations that cause cryptographic keys to be generated and placed on the AP and the STA. Frames are exchanged between the AP and STA only.
- **Protected data transfer:** Frames are exchanged between the STA and the end station through the AP. As denoted by the shading and the encryption module icon, secure data transfer occurs between the STA and the AP only; security is not provided end-to-end.

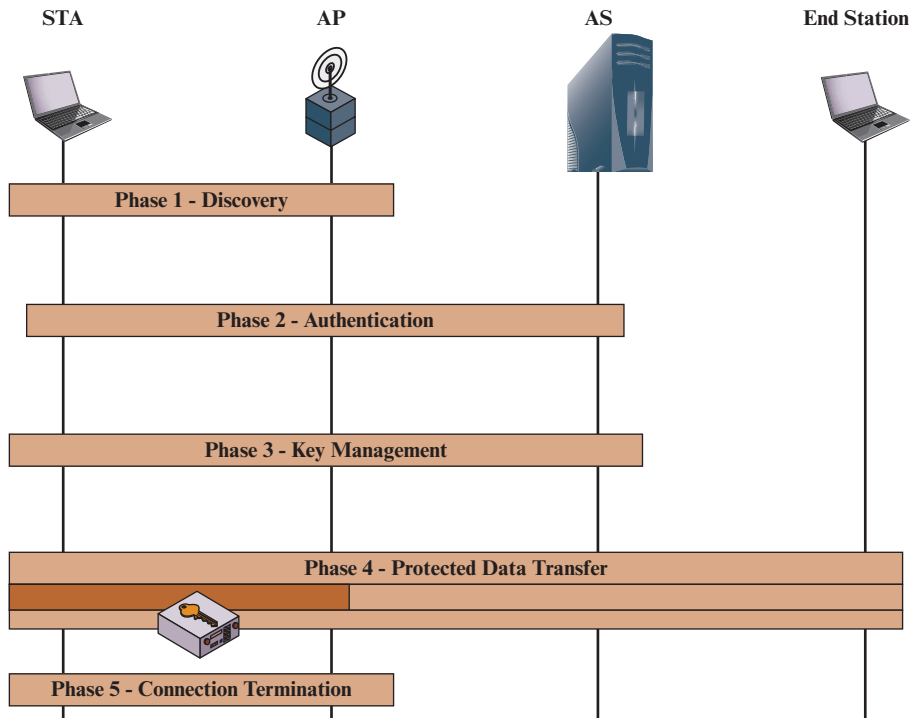

Figure 18.7 IEEE 802.11i Phases of Operation

- **Connection termination:** The AP and STA exchange frames. During this phase, the secure connection is torn down and the connection is restored to the original state.

Discovery Phase

We now look in more detail at the RSN phases of operation, beginning with the discovery phase, which is illustrated in the upper portion of Figure 18.8. The purpose of this phase is for an STA and an AP to recognize each other, agree on a set of security capabilities, and establish an association for future communication using those security capabilities.

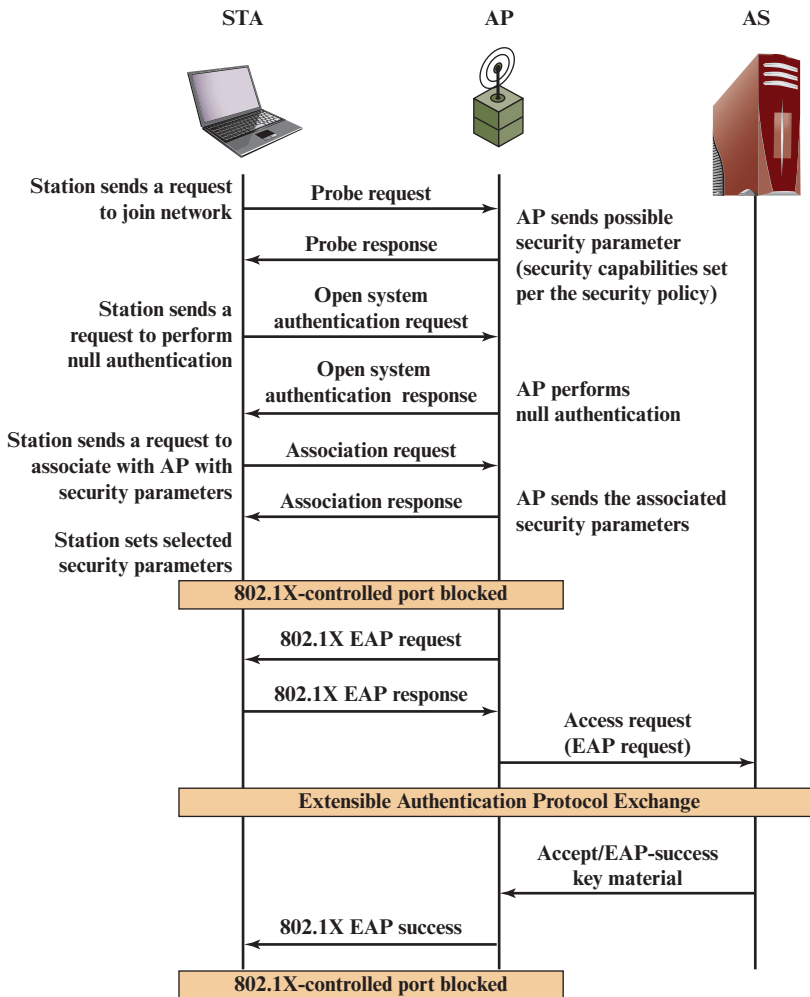

Figure 18.8 IEEE 802.11i Phases of Operation: Capability Discovery, Authentication, and Association

SECURITY CAPABILITIES During this phase, the STA and AP decide on specific techniques in the following areas:

- Confidentiality and MPDU integrity protocols for protecting unicast traffic (traffic only between this STA and AP)
- Authentication method
- Cryptography key management approach

Confidentiality and integrity protocols for protecting multicast/broadcast traffic are dictated by the AP, since all STAs in a multicast group must use the same protocols and ciphers. The specification of a protocol, along with the chosen key length (if variable) is known as a *cipher suite*. The options for the confidentiality and integrity cipher suite are

- WEP, with either a 40-bit or 104-bit key, which allows backward compatibility with older IEEE 802.11 implementations
- TKIP
- CCMP
- Vendor-specific methods

The other negotiable suite is the authentication and key management (AKM) suite, which defines (1) the means by which the AP and STA perform mutual authentication and (2) the means for deriving a root key from which other keys may be generated. The possible AKM suites are

- IEEE 802.1X
- Pre-shared key (no explicit authentication takes place and mutual authentication is implied if the STA and AP share a unique secret key)
- Vendor-specific methods

MPDU EXCHANGE The discovery phase consists of three exchanges.

- **Network and security capability discovery:** During this exchange, STAs discover the existence of a network with which to communicate. The AP either periodically broadcasts its security capabilities (not shown in figure), indicated by RSN IE (Robust Security Network Information Element), in a specific channel through the Beacon frame; or responds to a station's Probe Request through a Probe Response frame. A wireless station may discover available access points and corresponding security capabilities by either passively monitoring the Beacon frames or actively probing every channel.
- **Open system authentication:** The purpose of this frame sequence, which provides no security, is simply to maintain backward compatibility with the IEEE 802.11 state machine, as implemented in existing IEEE 802.11 hardware. In essence, the two devices (STA and AP) simply exchange identifiers.
- **Association:** The purpose of this stage is to agree on a set of security capabilities to be used. The STA then sends an Association Request frame to the AP. In this frame, the STA specifies one set of matching capabilities

(one authentication and key management suite, one pairwise cipher suite, and one group-key cipher suite) from among those advertised by the AP. If there is no match in capabilities between the AP and the STA, the AP refuses the Association Request. The STA blocks it too, in case it has associated with a rogue AP or someone is inserting frames illicitly on its channel. As shown in Figure 18.8, the IEEE 802.1X controlled ports are blocked, and no user traffic goes beyond the AP. The concept of blocked ports is explained subsequently.

Authentication Phase

As was mentioned, the authentication phase enables mutual authentication between an STA and an authentication server (AS) located in the DS. Authentication is designed to allow only authorized stations to use the network and to provide the STA with assurance that it is communicating with a legitimate network.

IEEE 802.1X ACCESS CONTROL APPROACH IEEE 802.11i makes use of another standard that was designed to provide access control functions for LANs. The standard is IEEE 802.1X, Port-Based Network Access Control. The authentication protocol that is used, the Extensible Authentication Protocol (EAP), is defined in the IEEE 802.1X standard. IEEE 802.1X uses the terms *supplicant*, *authenticator*, and *authentication server* (AS). In the context of an 802.11 WLAN, the first two terms correspond to the wireless station and the AP. The AS is typically a separate device on the wired side of the network (i.e., accessible over the DS) but could also reside directly on the authenticator.

Before a supplicant is authenticated by the AS using an authentication protocol, the authenticator only passes control or authentication messages between the supplicant and the AS; the 802.1X control channel is unblocked, but the 802.11 data channel is blocked. Once a supplicant is authenticated and keys are provided, the authenticator can forward data from the supplicant, subject to predefined access control limitations for the supplicant to the network. Under these circumstances, the data channel is unblocked.

As indicated in Figure 16.5, 802.1X uses the concepts of controlled and uncontrolled ports. Ports are logical entities defined within the authenticator and refer to physical network connections. For a WLAN, the authenticator (the AP) may have only two physical ports: one connecting to the DS and one for wireless communication within its BSS. Each logical port is mapped to one of these two physical ports. An uncontrolled port allows the exchange of PDUs between the supplicant and the other AS, regardless of the authentication state of the supplicant. A controlled port allows the exchange of PDUs between a supplicant and other systems on the LAN only if the current state of the supplicant authorizes such an exchange. IEEE 802.1X is covered in more detail in Chapter 16.

The 802.1X framework, with an upper-layer authentication protocol, fits nicely with a BSS architecture that includes a number of wireless stations and an AP. However, for an IBSS, there is no AP. For an IBSS, 802.11i provides a more complex solution that, in essence, involves pairwise authentication between stations on the IBSS.

MPDU EXCHANGE The lower part of Figure 18.8 shows the MPDU exchange dictated by IEEE 802.11 for the authentication phase. We can think of authentication phase as consisting of the following three phases.

- **Connect to AS:** The STA sends a request to its AP (the one with which it has an association) for connection to the AS. The AP acknowledges this request and sends an access request to the AS.
- **EAP exchange:** This exchange authenticates the STA and AS to each other. A number of alternative exchanges are possible, as explained subsequently.
- **Secure key delivery:** Once authentication is established, the AS generates a master session key (MSK), also known as the Authentication, Authorization, and Accounting (AAA) key and sends it to the STA. As explained subsequently, all the cryptographic keys needed by the STA for secure communication with its AP are generated from this MSK. IEEE 802.11i does not prescribe a method for secure delivery of the MSK but relies on EAP for this. Whatever method is used, it involves the transmission of an MPDU containing an encrypted MSK from the AS, via the AP, to the STA.

EAP EXCHANGE As mentioned, there are a number of possible EAP exchanges that can be used during the authentication phase. Typically, the message flow between STA and AP employs the EAP over LAN (EAPOL) protocol, and the message flow between the AP and AS uses the Remote Authentication Dial In User Service (RADIUS) protocol, although other options are available for both STA-to-AP and AP-to-AS exchanges. [FRAN07] provides the following summary of the authentication exchange using EAPOL and RADIUS.

1. The EAP exchange begins with the AP issuing an EAP-Request/Identity frame to the STA.
2. The STA replies with an EAP-Response/Identity frame, which the AP receives over the uncontrolled port. The packet is then encapsulated in RADIUS over EAP and passed on to the RADIUS server as a RADIUS-Access-Request packet.
3. The AAA server replies with a RADIUS-Access-Challenge packet, which is passed on to the STA as an EAP-Request. This request is of the appropriate authentication type and contains relevant challenge information.
4. The STA formulates an EAP-Response message and sends it to the AS. The response is translated by the AP into a Radius-Access-Request with the response to the challenge as a data field. Steps 3 and 4 may be repeated multiple times, depending on the EAP method in use. For TLS tunneling methods, it is common for authentication to require 10 to 20 round trips.
5. The AAA server grants access with a Radius-Access-Accept packet. The AP issues an EAP-Success frame. (Some protocols require confirmation of the EAP success inside the TLS tunnel for authenticity validation.) The controlled port is authorized, and the user may begin to access the network.

Note from Figure 18.8 that the AP controlled port is still blocked to general user traffic. Although the authentication is successful, the ports remain blocked until

the temporal keys are installed in the STA and AP, which occurs during the 4-Way Handshake.

Key Management Phase

During the key management phase, a variety of cryptographic keys are generated and distributed to STAs. There are two types of keys: pairwise keys used for communication between an STA and an AP and group keys used for multicast communication. Figure 18.9, based on [FRAN07], shows the two key hierarchies, and Table 18.3 defines the individual keys.

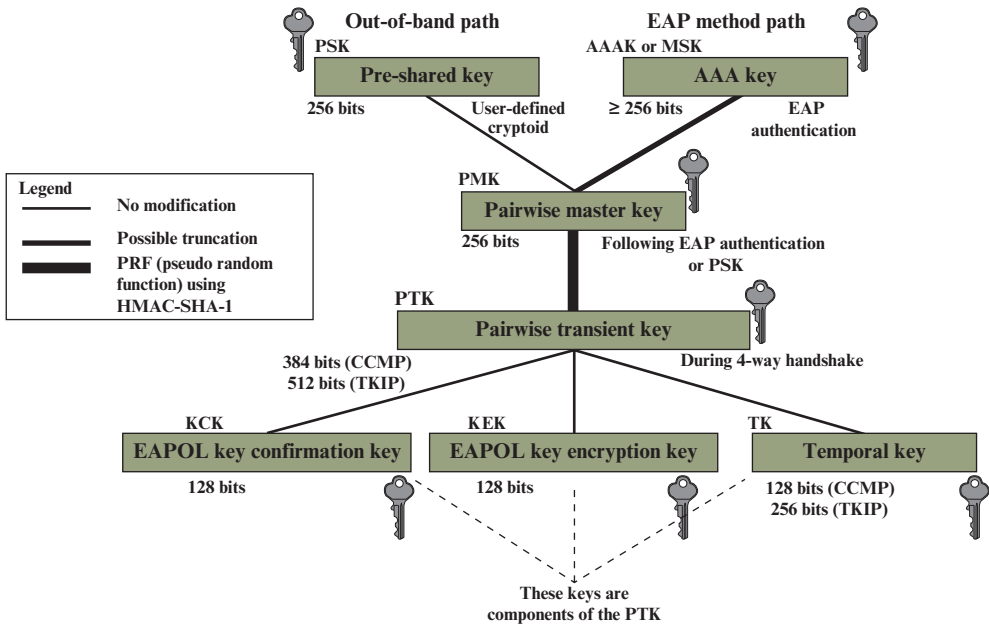

(a) Pairwise key hierarchy

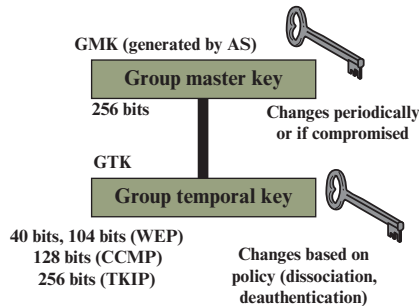

(b) Group key hierarchy

Figure 18.9 IEEE 802.11i Key Hierarchies

Table 18.3 IEEE 802.11i Keys for Data Confidentiality and Integrity Protocols

Abbreviation	Name	Description / Purpose	Size (bits)	Type
AAA Key	Authentication, Accounting, and Authorization Key	Used to derive the PMK. Used with the IEEE 802.1X authentication and key management approach. Same as MMSK.	≥ 256	Key generation key, root key
PSK	Pre-shared Key	Becomes the PMK in pre-shared key environments.	256	Key generation key, root key
PMK	Pairwise Master Key	Used with other inputs to derive the PTK.	256	Key generation key
GMK	Group Master Key	Used with other inputs to derive the GTK.	128	Key generation key
PTK	Pair-wise Transient Key	Derived from the PMK. Comprises the EAPOL-KCK, EAPOL-KEK, and TK and (for TKIP) the MIC key.	512 (TKIP) 384 (CCMP)	Composite key
TK	Temporal Key	Used with TKIP or CCMP to provide confidentiality and integrity protection for unicast user traffic.	256 (TKIP) 128 (CCMP)	Traffic key
GTK	Group Temporal Key	Derived from the GMK. Used to provide confidentiality and integrity protection for multicast/broadcast user traffic.	256 (TKIP) 128 (CCMP) 40,104 (WEP)	Traffic key
MIC Key	Message Integrity Code Key	Used by TKIP's Michael MIC to provide integrity protection of messages.	64	Message integrity key
EAPOL-KCK	EAPOL-Key Confirmation Key	Used to provide integrity protection for key material distributed during the 4-Way Handshake.	128	Message integrity key
EAPOL-KEK	EAPOL-Key Encryption Key	Used to ensure the confidentiality of the GTK and other key material in the 4-Way Handshake.	128	Traffic key / key encryption key
WEP Key	Wired Equivalent Privacy Key	Used with WEP.	40,104	Traffic key

PAIRWISE KEYS **Pairwise keys** are used for communication between a pair of devices, typically between an STA and an AP. These keys form a hierarchy beginning with a master key from which other keys are derived dynamically and used for a limited period of time.

At the top level of the hierarchy are two possibilities. A **pre-shared key (PSK)** is a secret key shared by the AP and a STA and installed in some fashion outside the scope of IEEE 802.11i. The other alternative is the **master session key (MSK)**, also known as the AAK, which is generated using the IEEE 802.1X protocol during the authentication phase, as described previously. The actual method of key generation depends on the details of the authentication protocol used. In either case (PSK or MSK), there is a unique key shared by the AP with each STA with which it communicates. All the other keys derived from this master key are also unique between an AP and an STA. Thus, each STA, at any time, has one set of keys, as depicted in the hierarchy of Figure 18.9a, while the AP has one set of such keys for each of its STAs.

The **pairwise master key (PMK)** is derived from the master key. If a PSK is used, then the PSK is used as the PMK; if a MSK is used, then the PMK is derived from the MSK by truncation (if necessary). By the end of the authentication phase, marked by the 802.1X EAP Success message (Figure 18.8), both the AP and the STA have a copy of their shared PMK.

The PMK is used to generate the **pairwise transient key (PTK)**, which in fact consists of three keys to be used for communication between an STA and AP after they have been mutually authenticated. To derive the PTK, the HMAC-SHA-1 function is applied to the PMK, the MAC addresses of the STA and AP, and nonces generated when needed. Using the STA and AP addresses in the generation of the PTK provides protection against session hijacking and impersonation; using nonces provides additional random keying material.

The three parts of the PTK are as follows.

- **EAP Over LAN (EAPOL) Key Confirmation Key (EAPOL-KCK):** Supports the integrity and data origin authenticity of STA-to-AP control frames during operational setup of an RSN. It also performs an access control function: proof-of-possession of the PMK. An entity that possesses the PMK is authorized to use the link.
- **EAPOL Key Encryption Key (EAPOL-KEK):** Protects the confidentiality of keys and other data during some RSN association procedures.
- **Temporal Key (TK):** Provides the actual protection for user traffic.

GROUP KEYS **Group keys** are used for multicast communication in which one STA sends MPDU's to multiple STAs. At the top level of the group key hierarchy is the **group master key (GMK)**. The GMK is a key-generating key used with other inputs to derive the **group temporal key (GTK)**. Unlike the PTK, which is generated using material from both AP and STA, the GTK is generated by the AP and transmitted to its associated STAs. Exactly how this GTK is generated is undefined. IEEE 802.11i, however, requires that its value is computationally indistinguishable from

random. The GTK is distributed securely using the pairwise keys that are already established. The GTK is changed every time a device leaves the network.

PAIRWISE KEY DISTRIBUTION The upper part of Figure 18.10 shows the MPDU exchange for distributing pairwise keys. This exchange is known as the 4-way handshake. The STA and AP use this handshake to confirm the existence of the

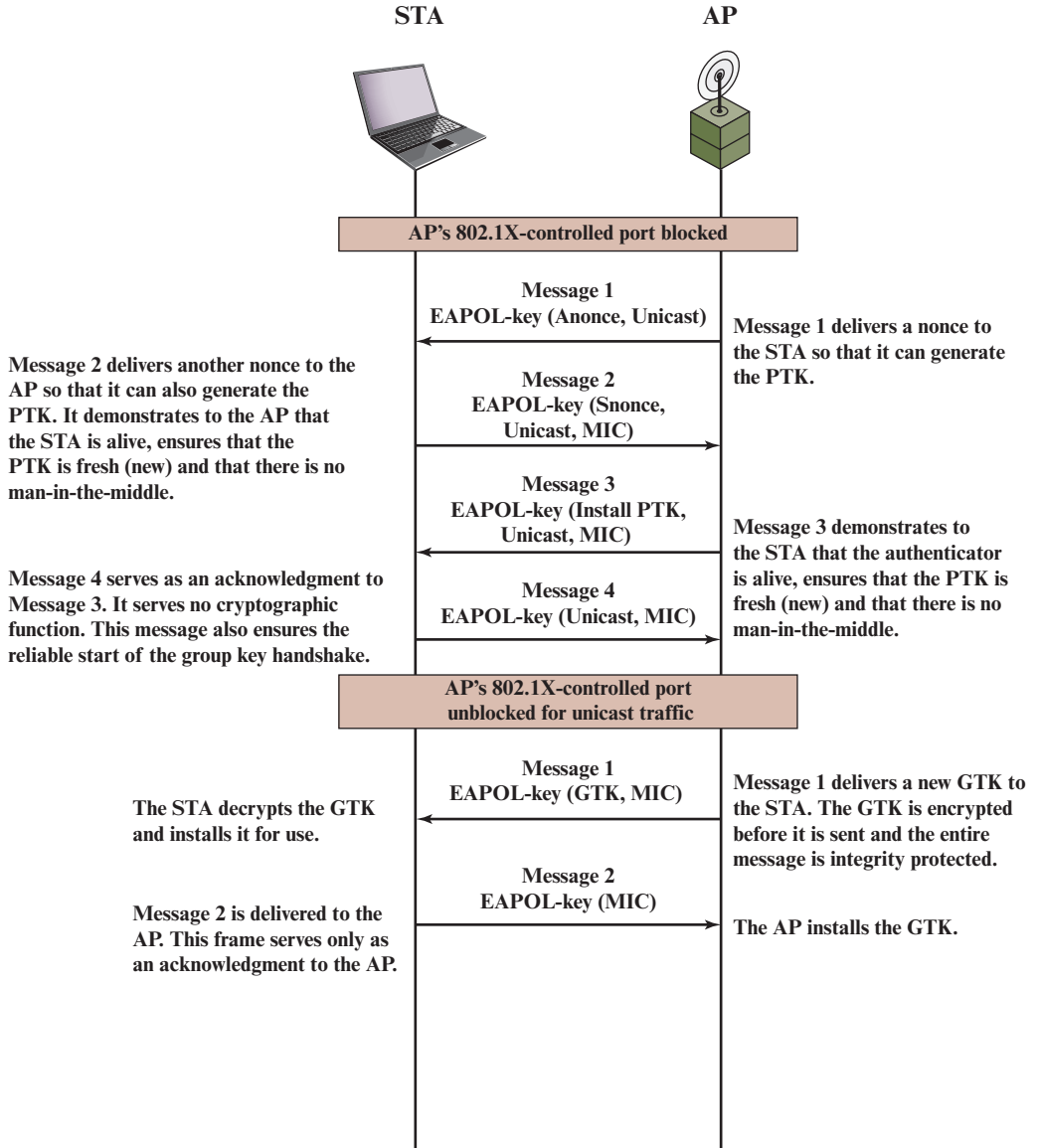

Figure 18.10 IEEE 802.11i Phases of Operation: Four-Way Handshake and Group Key Handshake

PMK, verify the selection of the cipher suite, and derive a fresh PTK for the following data session. The four parts of the exchange are as follows.

- **AP → STA:** Message includes the MAC address of the AP and a nonce (Anonce)
- **STA → AP:** The STA generates its own nonce (Snonce) and uses both nonces and both MAC addresses, plus the PMK, to generate a PTK. The STA then sends a message containing its MAC address and Snonce, enabling the AP to generate the same PTK. This message includes a message integrity code (MIC)² using HMAC-MD5 or HMAC-SHA-1-128. The key used with the MIC is KCK.
- **AP → STA:** The AP is now able to generate the PTK. The AP then sends a message to the STA, containing the same information as in the first message, but this time including a MIC.
- **STA → AP:** This is merely an acknowledgment message, again protected by a MIC.

GROUP KEY DISTRIBUTION For group key distribution, the AP generates a GTK and distributes it to each STA in a multicast group. The two-message exchange with each STA consists of the following:

- **AP → STA:** This message includes the GTK, encrypted either with RC4 or with AES. The key used for encryption is KEK, using a key wrapping algorithm (as discussed in Chapter 12). A MIC value is appended.
- **STA → AP:** The STA acknowledges receipt of the GTK. This message includes a MIC value.

Protected Data Transfer Phase

IEEE 802.11i defines two schemes for protecting data transmitted in 802.11 MPDUs: the Temporal Key Integrity Protocol (TKIP), and the Counter Mode-CBC MAC Protocol (CCMP).

TKIP TKIP is designed to require only software changes to devices that are implemented with the older wireless LAN security approach called Wired Equivalent Privacy (WEP). TKIP provides two services:

- **Message integrity:** TKIP adds a message integrity code (MIC) to the 802.11 MAC frame after the data field. The MIC is generated by an algorithm, called Michael, that computes a 64-bit value using as input the source and destination MAC address values and the Data field, plus key material.
- **Data confidentiality:** Data confidentiality is provided by encrypting the MPDU plus MIC value using RC4.

² While *MAC* is commonly used in cryptography to refer to a Message Authentication Code, the term *MIC* is used instead in connection with 802.11i because *MAC* has another standard meaning, Media Access Control, in networking.

The 256-bit TK (Figure 18.9) is employed as follows. Two 64-bit keys are used with the Michael message digest algorithm to produce a message integrity code. One key is used to protect STA-to-AP messages, and the other key is used to protect AP-to-STA messages. The remaining 128 bits are truncated to generate the RC4 key used to encrypt the transmitted data.

For additional protection, a monotonically increasing TKIP sequence counter (TSC) is assigned to each frame. The TSC serves two purposes. First, the TSC is included with each MPDU and is protected by the MIC to protect against replay attacks. Second, the TSC is combined with the session TK to produce a dynamic encryption key that changes with each transmitted MPDU, thus making cryptanalysis more difficult.

CCMP CCMP is intended for newer IEEE 802.11 devices that are equipped with the hardware to support this scheme. As with TKIP, CCMP provides two services:

- **Message integrity:** CCMP uses the cipher block chaining message authentication code (CBC-MAC), described in Chapter 12.
- **Data confidentiality:** CCMP uses the CTR block cipher mode of operation with AES for encryption. CTR is described in Chapter 7.

The same 128-bit AES key is used for both integrity and confidentiality. The scheme uses a 48-bit packet number to construct a nonce to prevent replay attacks.

The IEEE 802.11i Pseudorandom Function

At a number of places in the IEEE 802.11i scheme, a **pseudorandom function (PRF)** is used. For example, it is used to generate nonces, to expand pairwise keys, and to generate the GTK. Best security practice dictates that different pseudorandom number streams be used for these different purposes. However, for implementation efficiency, we would like to rely on a single pseudorandom number generator function.

The PRF is built on the use of HMAC-SHA-1 to generate a pseudorandom bit stream. Recall that HMAC-SHA-1 takes a message (block of data) and a key of length at least 160 bits and produces a 160-bit hash value. SHA-1 has the property that the change of a single bit of the input produces a new hash value with no apparent connection to the preceding hash value. This property is the basis for pseudorandom number generation.

The IEEE 802.11i PRF takes four parameters as input and produces the desired number of random bits. The function is of the form $\text{PRF}(K, A, B, Len)$, where

K = a secret key

A = a text string specific to the application (e.g., nonce generation or pairwise key expansion)

B = some data specific to each case

Len = desired number of pseudorandom bits

For example, for the pairwise transient key for CCMP:

$$\text{PTK} = \text{PRF}(\text{PMK}, \text{"Pairwise key expansion"}, \min(\text{AP-Addr}, \text{STA-Addr}) \parallel \max(\text{AP-Addr}, \text{STA-Addr}) \parallel \min(\text{Anonce}, \text{Snonce}) \parallel \max(\text{Anonce}, \text{Snonce}), 384)$$

So, in this case, the parameters are

$K = \text{PMK}$

$A =$ the text string “Pairwise key expansion”

$B =$ a sequence of bytes formed by concatenating the two MAC addresses and the two nonces

$Len = 384$ bits

Similarly, a nonce is generated by

Nonce = PRF (Random Number, “InitCounter”, MAC || Time, 256)

where **Time** is a measure of the network time known to the nonce generator.

The group temporal key is generated by

GTK = PRF (GMK, “Group key expansion”, MAC || Gnonce, 256)

Figure 18.11 illustrates the function PRF(K, A, B, Len). The parameter K serves as the key input to HMAC. The message input consists of four items concatenated together: the parameter A , a byte with value 0, the parameter B , and a counter i . The counter is initialized to 0. The HMAC algorithm is run once, producing a 160-bit hash value. If more bits are required, HMAC is run again with the same inputs, except that i is incremented each time until the necessary number of bits is generated. We can express the logic as

```

PRF ( $K, A, B, Len$ )
   $R \leftarrow$  null string
  for  $i \leftarrow 0$  to  $((Len + 159)/160 - 1)$  do
     $R \leftarrow R || \text{HMAC-SHA-1} (K, A || 0 || B || i)$ 
  Return Truncate-to-Len ( $R, Len$ )
    
```

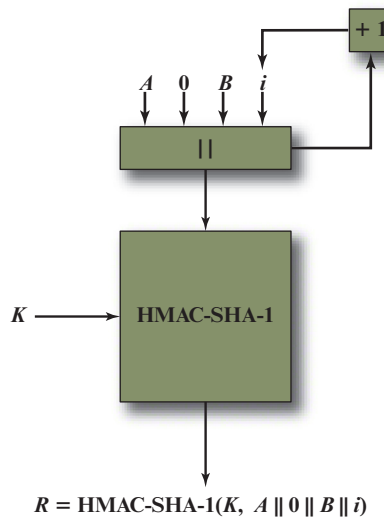

Figure 18.11 IEEE 802.11i Pseudorandom Function

18.5 KEY TERMS, REVIEW QUESTIONS, AND PROBLEMS

Key Terms

group keys IEEE 802.11	media access control (MAC) pairwise keys	pseudorandom function (PRF) Wi-Fi
---------------------------	---	--------------------------------------

Review Questions

- 18.1 What is the basic building block of an 802.11 WLAN?
- 18.2 List and briefly define threats to a wireless network.
- 18.3 List and briefly define IEEE 802.11 services.
- 18.4 List some security threats related to mobile devices.
- 18.5 How is the concept of an association related to that of mobility?
- 18.6 What security areas are addressed by IEEE 802.11i?
- 18.7 Briefly describe the five IEEE 802.11i phases of operation.
- 18.8 What is the difference between TKIP and CCMP?

Problems

- 18.1 In IEEE 802.11, open system authentication simply consists of two communications. An authentication is requested by the client, which contains the station ID (typically the MAC address). This is followed by an authentication response from the AP/router containing a success or failure message. An example of when a failure may occur is if the client's MAC address is explicitly excluded in the AP/router configuration.
 - a. What are the benefits of this authentication scheme?
 - b. What are the security vulnerabilities of this authentication scheme?
- 18.2 Prior to the introduction of IEEE 802.11i, the security scheme for IEEE 802.11 was Wired Equivalent Privacy (WEP). WEP assumed all devices in the network share a secret key. The purpose of the authentication scenario is for the STA to prove that it possesses the secret key. Authentication proceeds as shown in Figure 18.12. The STA sends a message to the AP requesting authentication. The AP issues a challenge, which is a sequence of 128 random bytes sent as plaintext. The STA encrypts the challenge with the shared key and returns it to the AP. The AP decrypts the incoming value and compares it to the challenge that it sent. If there is a match, the AP confirms that authentication has succeeded.
 - a. What are the benefits of this authentication scheme?
 - b. This authentication scheme is incomplete. What is missing and why is this important? *Hint:* The addition of one or two messages would fix the problem.
 - c. What is a cryptographic weakness of this scheme?

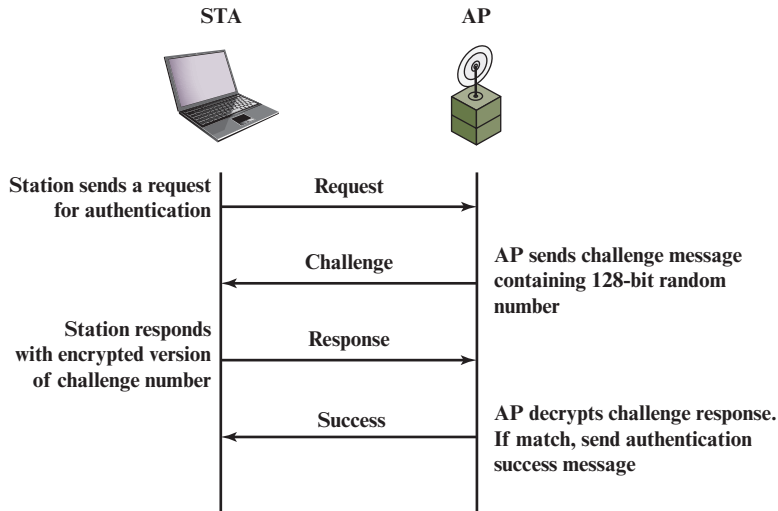

Figure 18.12 WEP Authentication; refer to Problem 18.2

- 18.3** For WEP, data integrity and data confidentiality are achieved using the RC4 stream encryption algorithm. The transmitter of an MPDU performs the following steps, referred to as encapsulation:
1. The transmitter selects an initial vector (IV) value.
 2. The IV value is concatenated with the WEP key shared by transmitter and receiver to form the seed, or key input, to RC4.
 3. A 32-bit cyclic redundancy check (CRC) is computed over all the bits of the MAC data field and appended to the data field. The CRC is a common error-detection code used in data link control protocols. In this case, the CRC serves as an integrity check value (ICV).
 4. The result of step 3 is encrypted using RC4 to form the ciphertext block.
 5. The plaintext IV is prepended to the ciphertext block to form the encapsulated MPDU for transmission.
 - a. Draw a block diagram that illustrates the encapsulation process.
 - b. Describe the steps at the receiver end to recover the plaintext and perform the integrity check.
 - c. Draw a block diagram that illustrates part b.
- 18.4** A potential weakness of the CRC as an integrity check is that it is a linear function. This means that you can predict which bits of the CRC are changed if a single bit of the message is changed. Furthermore, it is possible to determine which combination of bits could be flipped in the message so that the net result is no change in the CRC. Thus, there are a number of combinations of bit flippings of the plaintext message that leave the CRC unchanged, so message integrity is defeated. However, in WEP, if an attacker does not know the encryption key, the attacker does not have access to the plaintext, only to the ciphertext block. Does this mean that the ICV is protected from the bit flipping attack? Explain.

CHAPTER 19

ELECTRONIC MAIL SECURITY

19.1 Internet Mail Architecture

- Email Components
- Email Protocols

19.2 Email Formats

- RFC 5322
- Multipurpose Internet Mail Extensions

19.3 Email Threats and Comprehensive Email Security

19.4 S/MIME

- Operational Description
- S/MIME Message Content Types
- S/MIME Messages
- S/MIME Certificate Processing
- Enhanced Security Services

19.5 DNSSEC

- Domain Name System
- DNS Security Extensions

19.6 DNS-Based Authentication of Named Entities

- TLSA Record
- Use of DANE for SMTP
- Use of DNSSEC for S/MIME

19.7 Sender Policy Framework

- SPF on the Sender Side
- SPF on the Receiver Side

19.8 DomainKeys Identified Mail

- Email Threats
- DKIM Strategy
- DKIM Functional Flow

19.9 Domain-Based Message Authentication, Reporting, and Conformance

- Identifier Alignment
- DMARC on the Sender Side
- DMARC on the Receiver Side
- DMARC Reports

19.10 Key Terms, Review Questions, and Problems

LEARNING OBJECTIVES

After studying this chapter, you should be able to:

- ◆ Summarize the key functional components of the Internet mail architecture.
- ◆ Explain the basic functionality of SMTP, POP3, and IMAP.
- ◆ Explain the need for MIME as an enhancement to ordinary email.
- ◆ Describe the key elements of MIME.
- ◆ Understand the functionality of S/MIME and the security threats it addresses.
- ◆ Understand the basic mechanisms of STARTTLS and its role in email security.
- ◆ Understand the basic mechanisms of DANE and its role in email security.
- ◆ Understand the basic mechanisms of SPF and its role in email security.
- ◆ Understand the basic mechanisms of DKIM and its role in email security.
- ◆ Understand the basic mechanisms of DMARC and its role in email security.

In virtually all distributed environments, **electronic mail** is the most heavily used network-based application. Users expect to be able to, and do, send email to others who are connected directly or indirectly to the Internet, regardless of host operating system or communications suite. With the explosively growing reliance on email, there grows a demand for authentication and confidentiality services. A complementary set of standards related to secure email have been developed. This chapter provides an overview.

19.1 INTERNET MAIL ARCHITECTURE

For an understanding of the topics in this chapter, it is useful to have a basic grasp of the Internet mail architecture, which is currently defined in RFC 5598 (*Internet Mail Architecture*, July 2009). This section provides an overview of the basic concepts.

Email Components

At its most fundamental level, the Internet mail architecture consists of a user world in the form of Message User Agents (MUA), and the transfer world, in the form of the Message Handling Service (MHS), which is composed of Message Transfer Agents (MTA). The MHS accepts a message from one user and delivers it to one or more other users, creating a virtual MUA-to-MUA exchange environment. This architecture involves three types of interoperability. One is directly between users: messages must be formatted by the MUA on behalf of the message author so that the message can be displayed to the message recipient by the destination MUA. There are also interoperability requirements between the MUA and the MHS—first when a message is posted from an MUA to the MHS and later when it is delivered from the MHS to the destination MUA. Interoperability is required among the MTA components along the transfer path through the MHS.

Figure 19.1 illustrates the key components of the Internet mail architecture, which include the following.

- **Message User Agent (MUA):** Operates on behalf of user actors and user applications. It is their representative within the email service. Typically, this function is housed in the user's computer and is referred to as a client email program or a local network email server. The author MUA formats a message and performs initial submission into the MHS via a MSA. The recipient MUA processes received mail for storage and/or display to the recipient user.
- **Mail Submission Agent (MSA):** Accepts the message submitted by an MUA and enforces the policies of the hosting domain and the requirements of Internet standards. This function may be located together with the MUA or as a separate functional model. In the latter case, the **Simple Mail Transfer Protocol (SMTP)** is used between the MUA and the MSA.
- **Message Transfer Agent (MTA):** Relays mail for one application-level hop. It is like a packet switch or IP router in that its job is to make routing assessments and to move the message closer to the recipients. Relaying is performed by a sequence of MTAs until the message reaches a destination MDA. An MTA also adds trace information to the message header. SMTP is used between MTAs and between an MTA and an MSA or MDA.
- **Mail Delivery Agent (MDA):** Responsible for transferring the message from the MHS to the MS.
- **Message Store (MS):** An MUA can employ a long-term MS. An MS can be located on a remote server or on the same machine as the MUA. Typically, an MUA retrieves messages from a remote server using POP (Post Office Protocol) or IMAP (Internet Message Access Protocol).

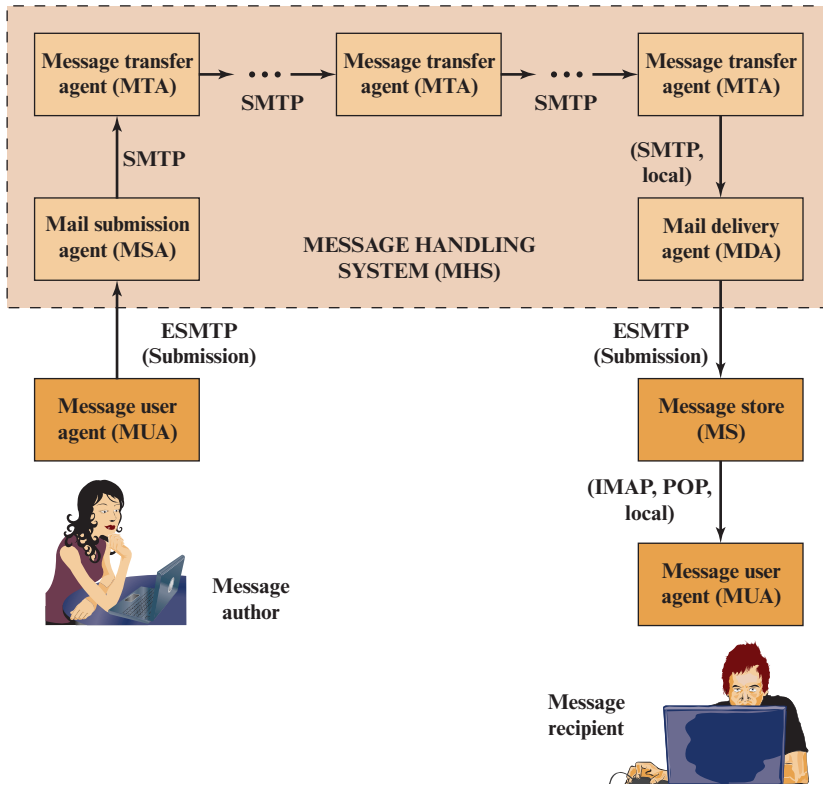

Figure 19.1 Function Modules and Standardized Protocols Used between them in the Internet Mail Architecture

Two other concepts need to be defined. An administrative management domain (ADMD) is an Internet email provider. Examples include a department that operates a local mail relay (MTA), an IT department that operates an enterprise mail relay, and an ISP that operates a public shared email service. Each ADMD can have different operating policies and trust-based decision making. One obvious example is the distinction between mail that is exchanged within an organization and mail that is exchanged between independent organizations. The rules for handling the two types of traffic tend to be quite different.

The Domain Name System (DNS) is a directory lookup service that provides a mapping between the name of a host on the Internet and its numerical address. DNS is discussed subsequently in this chapter.

Email Protocols

Two types of protocols are used for transferring email. The first type is used to move messages through the Internet from source to destination. The protocol used for this purpose is SMTP, with various extensions and in some cases restrictions. The second type consists of protocols used to transfer messages between mail servers, of which IMAP and POP are the most commonly used.

SIMPLE MAIL TRANSFER PROTOCOL SMTP encapsulates an email message in an envelope and is used to relay the encapsulated messages from source to destination through multiple MTAs. SMTP was originally specified in 1982 as RFC 821 and has undergone several revisions, the most current being RFC 5321 (October 2008). These revisions have added additional commands and introduced extensions. The term Extended SMTP (ESMTP) is often used to refer to these later versions of SMTP.

SMTP is a text-based client-server protocol where the client (email sender) contacts the server (next-hop recipient) and issues a set of commands to tell the server about the message to be sent, then sending the message itself. The majority of these commands are ASCII text messages sent by the client and a resulting return code (and additional ASCII text) returned by the server.

The transfer of a message from a source to its ultimate destination can occur over a single SMTP client/server conversation over a single TCP connection. Alternatively, an SMTP server may be an intermediate relay that assumes the role of an SMTP client after receiving a message and then forwards that message to an SMTP server along a route to the ultimate destination.

The operation of SMTP consists of a series of commands and responses exchanged between the SMTP sender and receiver. The initiative is with the SMTP sender, who establishes the TCP connection. Once the connection is established, the SMTP sender sends commands over the connection to the receiver. Each command consists of a single line of text, beginning with a four-letter command code followed in some cases by an argument field. Each command generates exactly one reply from the SMTP receiver. Most replies are a single-line, although multiple-line replies are possible. Each reply begins with a three-digit code and may be followed by additional information.

Similar mechanisms are available for running TLS over IMAP and POP protocols.

Historically, MUA/MSA message transfers have used SMTP. The standard currently preferred is SUBMISSION, defined in RFC 6409 (*Message Submission for Mail*, November 2011). Although SUBMISSION derives from SMTP, it uses a separate TCP port and imposes distinct requirements, such as access authorization.

MAIL ACCESS PROTOCOLS (POP3, IMAP) Post Office Protocol (POP3) allows an email client (user agent) to download an email from an email server (MTA). POP3 user agents connect via TCP to the server (typically port 110). The user agent enters a username and password (either stored internally for convenience or entered each time by the user for stronger security). After authorization, the UA can issue POP3 commands to retrieve and delete mail.

As with POP3, Internet Mail Access Protocol (IMAP) also enables an email client to access mail on an email server. IMAP also uses TCP, with server TCP port 143. IMAP is more complex than POP3. IMAP provides stronger authentication than POP3 and provides other functions not supported by POP3.

19.2 EMAIL FORMATS

To understand S/MIME, we need first to have a general understanding of the underlying email format that it uses, namely, MIME. But to understand the significance of MIME, we need to go back to the traditional email format standard,

RFC 822, which is still in common use. The most recent version of this format specification is RFC 5322 (*Internet Message Format*, October 2008). Accordingly, this section first provides an introduction to these two earlier standards and then moves on to a discussion of S/MIME.

RFC 5322

RFC 5322 defines a format for text messages that are sent using electronic mail. It has been the standard for Internet-based text mail messages and remains in common use. In the RFC 5322 context, messages are viewed as having an envelope and contents. The envelope contains whatever information is needed to accomplish transmission and delivery. The contents compose the object to be delivered to the recipient. The RFC 5322 standard applies only to the contents. However, the content standard includes a set of header fields that may be used by the mail system to create the envelope, and the standard is intended to facilitate the acquisition of such information by programs.

The overall structure of a message that conforms to RFC 5322 is very simple. A message consists of some number of header lines (*the header*) followed by unrestricted text (*the body*). The header is separated from the body by a blank line. Put differently, a message is ASCII text, and all lines up to the first blank line are assumed to be header lines used by the user agent part of the mail system.

A header line usually consists of a keyword, followed by a colon, followed by the keyword's arguments; the format allows a long line to be broken up into several lines. The most frequently used keywords are *From*, *To*, *Subject*, and *Date*. Here is an example message:

```
Date: October 8, 2009 2:15:49 PM EDT
From: "William Stallings" <ws@shore.net>
Subject: The Syntax in RFC 5322
To: Smith@Other-host.com
Cc: Jones@Yet-Another-Host.com
```

```
Hello. This section begins the actual
message body, which is delimited from the
message heading by a blank line.
```

Another field that is commonly found in RFC 5322 headers is *Message-ID*. This field contains a unique identifier associated with this message.

Multipurpose Internet Mail Extensions

Multipurpose Internet Mail Extension (MIME) is an extension to the RFC 5322 framework that is intended to address some of the problems and limitations of the use of Simple Mail Transfer Protocol (SMTP) or some other mail transfer protocol and RFC 5322 for electronic mail. RFCs 2045 through 2049 define MIME, and there have been a number of updating documents since then.

As justification for the use of MIME, [PARZ06] lists the following limitations of the SMTP/5322 scheme.

1. SMTP cannot transmit executable files or other binary objects. A number of schemes are in use for converting binary files into a text form that can be used by SMTP mail systems, including the popular UNIX UUencode/UUdecode scheme. However, none of these is a standard or even a *de facto* standard.
2. SMTP cannot transmit text data that includes national language characters, because these are represented by 8-bit codes with values of 128 decimal or higher, and SMTP is limited to 7-bit ASCII.
3. SMTP servers may reject mail message over a certain size.
4. SMTP gateways that translate between ASCII and the character code EBCDIC do not use a consistent set of mappings, resulting in translation problems.
5. SMTP gateways to X.400 electronic mail networks cannot handle nontextual data included in X.400 messages.
6. Some SMTP implementations do not adhere completely to the SMTP standards defined in RFC 821. Common problems include:
 - Deletion, addition, or reordering of carriage return and linefeed
 - Truncating or wrapping lines longer than 76 characters
 - Removal of trailing white space (tab and space characters)
 - Padding of lines in a message to the same length
 - Conversion of tab characters into multiple space characters

MIME is intended to resolve these problems in a manner that is compatible with existing RFC 5322 implementations.

OVERVIEW The MIME specification includes the following elements.

1. Five new message header fields are defined, which may be included in an RFC 5322 header. These fields provide information about the body of the message.
2. A number of content formats are defined, thus standardizing representations that support multimedia electronic mail.
3. Transfer encodings are defined that enable the conversion of any content format into a form that is protected from alteration by the mail system.

In this subsection, we introduce the five message header fields. The next two subsections deal with content formats and transfer encodings.

The five header fields defined in MIME are as follows:

- **MIME-Version:** Must have the parameter value 1.0. This field indicates that the message conforms to RFCs 2045 and 2046.
- **Content-Type:** Describes the data contained in the body with sufficient detail that the receiving user agent can pick an appropriate agent or mechanism to represent the data to the user or otherwise deal with the data in an appropriate manner.

- **Content-Transfer-Encoding:** Indicates the type of transformation that has been used to represent the body of the message in a way that is acceptable for mail transport.
- **Content-ID:** Used to identify MIME entities uniquely in multiple contexts.
- **Content-Description:** A text description of the object with the body; this is useful when the object is not readable (e.g., audio data).

Any or all of these fields may appear in a normal RFC 5322 header. A compliant implementation must support the MIME-Version, Content-Type, and Content-Transfer-Encoding fields; the Content-ID and Content-Description fields are optional and may be ignored by the recipient implementation.

MIME CONTENT TYPES The bulk of the MIME specification is concerned with the definition of a variety of content types. This reflects the need to provide standardized ways of dealing with a wide variety of information representations in a multimedia environment.

Table 19.1 lists the content types specified in RFC 2046. There are seven different major types of content and a total of 15 subtypes. In general, a content type declares the general type of data, and the subtype specifies a particular format for that type of data.

Table 19.1 MIME Content Types

Type	Subtype	Description
Text	Plain	Unformatted text; may be ASCII or ISO 8859.
	Enriched	Provides greater format flexibility.
Multipart	Mixed	The different parts are independent but are to be transmitted together. They should be presented to the receiver in the order that they appear in the mail message.
	Parallel	Differs from Mixed only in that no order is defined for delivering the parts to the receiver.
	Alternative	The different parts are alternative versions of the same information. They are ordered in increasing faithfulness to the original, and the recipient's mail system should display the "best" version to the user.
Message	Digest	Similar to Mixed, but the default type/subtype of each part is message/rfc822.
	rfc822	The body is itself an encapsulated message that conforms to RFC 822.
	Partial	Used to allow fragmentation of large mail items, in a way that is transparent to the recipient.
Image	External-body	Contains a pointer to an object that exists elsewhere.
	jpeg	The image is in JPEG format, JFIF encoding.
Video	gif	The image is in GIF format.
	mpeg	MPEG format.
Audio	Basic	Single-channel 8-bit ISDN μ -law encoding at a sample rate of 8 kHz.
Application	PostScript	Adobe Postscript format.
	octet-stream	General binary data consisting of 8-bit bytes.

For the **text type** of body, no special software is required to get the full meaning of the text aside from support of the indicated character set. The primary subtype is *plain text*, which is simply a string of ASCII characters or ISO 8859 characters. The *enriched* subtype allows greater formatting flexibility.

The **multipart type** indicates that the body contains multiple, independent parts. The Content-Type header field includes a parameter (called boundary) that defines the delimiter between body parts. This boundary should not appear in any parts of the message. Each boundary starts on a new line and consists of two hyphens followed by the boundary value. The final boundary, which indicates the end of the last part, also has a suffix of two hyphens. Within each part, there may be an optional ordinary MIME header.

There are four subtypes of the multipart type, all of which have the same overall syntax. The **multipart/mixed subtype** is used when there are multiple independent body parts that need to be bundled in a particular order. For the **multipart/parallel subtype**, the order of the parts is not significant. If the recipient's system is appropriate, the multiple parts can be presented in parallel. For example, a picture or text part could be accompanied by a voice commentary that is played while the picture or text is displayed.

For the **multipart/alternative subtype**, the various parts are different representations of the same information.

In this subtype, the body parts are ordered in terms of increasing preference.

The **multipart/digest subtype** is used when each of the body parts is interpreted as an RFC 5322 message with headers. This subtype enables the construction of a message whose parts are individual messages. For example, the moderator of a group might collect email messages from participants, bundle these messages, and send them out in one encapsulating MIME message.

The **message type** provides a number of important capabilities in MIME. The **message/rfc822 subtype** indicates that the body is an entire message, including header and body. Despite the name of this subtype, the encapsulated message may be not only a simple RFC 5322 message, but also any MIME message.

The **message/partial subtype** enables fragmentation of a large message into a number of parts, which must be reassembled at the destination. For this subtype, three parameters are specified in the Content-Type: Message/Partial field: an *id* common to all fragments of the same message, a *sequence number* unique to each fragment, and the *total* number of fragments.

The **message/external-body subtype** indicates that the actual data to be conveyed in this message are not contained in the body. Instead, the body contains the information needed to access the data. As with the other message types, the message/external-body subtype has an outer header and an encapsulated message with its own header. The only necessary field in the outer header is the Content-Type field, which identifies this as a message/external-body subtype. The inner header is the message header for the encapsulated message. The Content-Type field in the outer header must include an access-type parameter, which indicates the method of access, such as FTP (file transfer protocol).

The **application type** refers to other kinds of data, typically either uninterpreted binary data or information to be processed by a mail-based application.

MIME TRANSFER ENCODINGS The other major component of the MIME specification, in addition to content type specification, is a definition of transfer encodings for message bodies. The objective is to provide reliable delivery across the largest range of environments.

The MIME standard defines two methods of encoding data. The Content-Transfer-Encoding field can actually take on six values, as listed in Table 19.2. However, three of these values (7-bit, 8-bit, and binary) indicate that no encoding has been done but provide some information about the nature of the data. For SMTP transfer, it is safe to use the 7-bit form. The 8-bit and binary forms may be usable in other mail transport contexts. Another Content-Transfer-Encoding value is *x-token*, which indicates that some other encoding scheme is used for which a name is to be supplied. This could be a vendor-specific or application-specific scheme. The two actual encoding schemes defined are quoted-printable and base64. Two schemes are defined to provide a choice between a transfer technique that is essentially human readable and one that is safe for all types of data in a way that is reasonably compact.

The **quoted-printable** transfer encoding is useful when the data consists largely of octets that correspond to printable ASCII characters. In essence, it represents nonsafe characters by the hexadecimal representation of their code and introduces reversible (soft) line breaks to limit message lines to 76 characters.

The **base64 transfer encoding**, also known as radix-64 encoding, is a common one for encoding arbitrary binary data in such a way as to be invulnerable to the processing by mail-transport programs.

CANONICAL FORM An important concept in MIME and S/MIME is that of canonical form. Canonical form is a format, appropriate to the content type, that is standardized for use between systems. This is in contrast to native form, which is a format that may be peculiar to a particular system. RFC 2049 defines these two forms as follows:

- **Native form:** The body to be transmitted is created in the system's native format. The native character set is used and, where appropriate, local end-of-line conventions are used as well. The body may be any format that corresponds to the local model for the representation of some form of information. Examples include a UNIX-style text file, or a Sun raster image, or a VMS indexed file, and audio data in a system-dependent format stored only in memory. In essence, the data are created in the native form that corresponds to the type specified by the media type.
- **Canonical form:** The entire body, including out-of-band information such as record lengths and possibly file attribute information, is converted to a universal canonical form. The specific media type of the body as well as its associated

Table 19.2 MIME Transfer Encodings

7 bit	The data are all represented by short lines of ASCII characters.
8 bit	The lines are short, but there may be non-ASCII characters (octets with the high-order bit set).
binary	Not only may non-ASCII characters be present but the lines are not necessarily short enough for SMTP transport.
quoted-printable	Encodes the data in such a way that if the data being encoded are mostly ASCII text, the encoded form of the data remains largely recognizable by humans.
base64	Encodes data by mapping 6-bit blocks of input to 8-bit blocks of output, all of which are printable ASCII characters.
x-token	A named nonstandard encoding.

attributes dictates the nature of the canonical form that is used. Conversion to the proper canonical form may involve character set conversion, transformation of audio data, compression, or various other operations specific to the various media types.

19.3 EMAIL THREATS AND COMPREHENSIVE EMAIL SECURITY

For both organizations and individuals, email is both pervasive and especially vulnerable to a wide range of security threats. In general terms, email security threats can be classified as follows:

- **Authenticity-related threats:** Could result in unauthorized access to an enterprise's email system.
- **Integrity-related threats:** Could result in unauthorized modification of email content.
- **Confidentiality-related threats:** Could result in unauthorized disclosure of sensitive information.
- **Availability-related threats:** Could prevent end users from being able to send or receive email.

A useful list of specific email threats, together with approaches to mitigation, is provided in NIST SP 800-177 (*Trustworthy Email*, September 2015) and is shown in Table 19.3.

SP 800-177 recommends use of a variety of standardized protocols as a means for countering these threats. These include:

- **STARTTLS:** An SMTP security extension that provides authentication, integrity, non-repudiation (via digital signatures) and confidentiality (via encryption) for the entire SMTP message by running SMTP over TLS.
- **S/MIME:** Provides authentication, integrity, non-repudiation (via digital signatures) and confidentiality (via encryption) of the message body carried in SMTP messages.
- **DNS Security Extensions (DNSSEC):** Provides authentication and integrity protection of DNS data, and is an underlying tool used by various email security protocols.
- **DNS-based Authentication of Named Entities (DANE):** Is designed to overcome problems in the certificate authority (CA) system by providing an alternative channel for authenticating public keys based on DNSSEC, with the result that the same trust relationships used to certify IP addresses are used to certify servers operating on those addresses.
- **Sender Policy Framework (SPF):** Uses the Domain Name System (DNS) to allow domain owners to create records that associate the domain name with a specific IP address range of authorized message senders. It is a simple matter for receivers to check the SPF TXT record in the DNS to confirm that the

Table 19.3 Email Threats and Mitigations

Threat	Impact on Purported Sender	Impact on Receiver	Mitigation
Email sent by unauthorized MTA in enterprise (e.g., malware botnet)	Loss of reputation, valid email from enterprise may be blocked as possible spam/phishing attack.	UBE and/or email containing malicious links may be delivered into user inboxes.	Deployment of domain-based authentication techniques. Use of digital signatures over email.
Email message sent using spoofed or unregistered sending domain	Loss of reputation, valid email from enterprise may be blocked as possible spam/phishing attack.	UBE and/or email containing malicious links may be delivered into user inboxes.	Deployment of domain-based authentication techniques. Use of digital signatures over email.
Email message sent using forged sending address or email address (i.e., phishing, spear phishing)	Loss of reputation, valid email from enterprise may be blocked as possible spam/phishing attack.	UBE and/or email containing malicious links may be delivered. Users may inadvertently divulge sensitive information or PII.	Deployment of domain-based authentication techniques. Use of digital signatures over email.
Email modified in transit	Leak of sensitive information or PII.	Leak of sensitive information, altered message may contain malicious information.	Use of TLS to encrypt email transfer between servers. Use of end-to-end email encryption.
Disclosure of sensitive information (e.g., PII) via monitoring and capturing of email traffic	Leak of sensitive information or PII.	Leak of sensitive information, altered message may contain malicious information.	Use of TLS to encrypt email transfer between servers. Use of end-to-end email encryption.
Unsolicited Bulk Email (UBE) (i.e., spam)	None, unless purported sender is spoofed.	UBE and/or email containing malicious links may be delivered into user inboxes.	Techniques to address UBE.
DoS/DDoS attack against an enterprises' email servers	Inability to send email.	Inability to receive email.	Multiple mail servers, use of cloud-based email providers.

purported sender of a message is permitted to use that source address and reject mail that does not come from an authorized IP address.

- **DomainKeys Identified Mail (DKIM):** Enables an MTA to sign selected headers and the body of a message. This validates the source domain of the mail and provides message body integrity.
- **Domain-based Message Authentication, Reporting, and Conformance (DMARC):** Lets senders know the proportionate effectiveness of their SPF and DKIM policies, and signals to receivers what action should be taken in various individual and bulk attack scenarios.

Figure 19.2 shows how these components interact to provide message authenticity and integrity. Not shown, for simplicity, is that S/MIME also provides message confidentiality by encrypting messages.

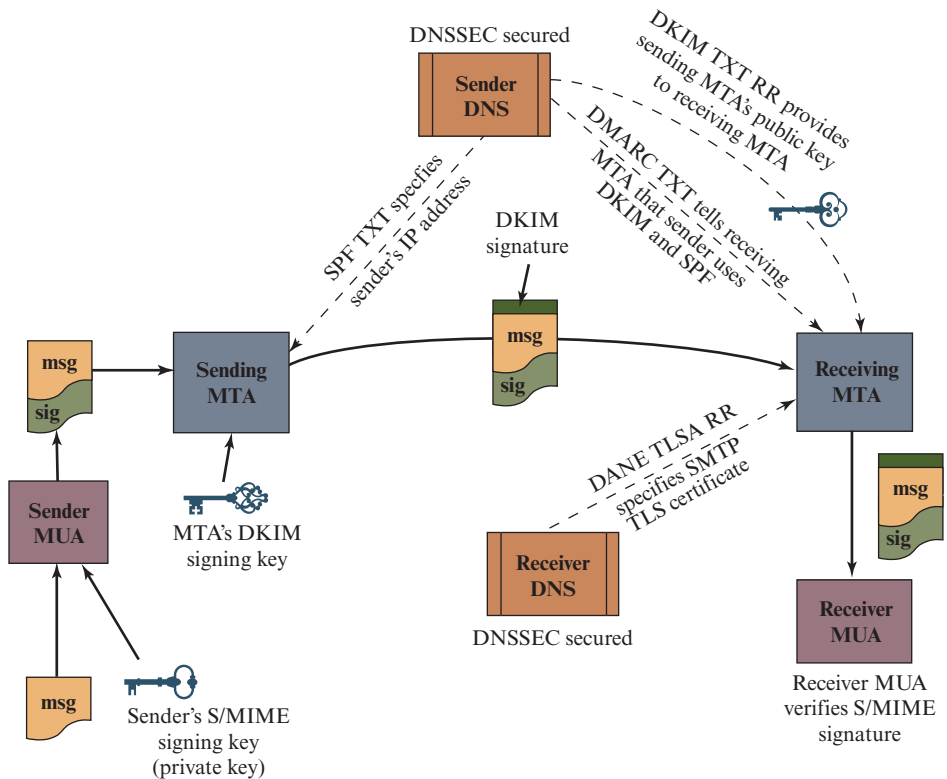

DANE = DNS-based Authentication of Named Entities
 DKIM = DomainKeys Identified Mail
 DMARC = Domain-based Message Authentication, Reporting, and Conformance
 DNSSEC = Domain Name System Security Extensions
 SPF = Sender Policy Framework
 S/MIME = Secure Multi-Purpose Internet Mail Extensions
 TLSA RR = Transport Layer Security Authentication Resource Record

Figure 19.2 The Interrelationship of DNSSEC, SPF, DKIM, DMARC, DANE, and S/MIME for Assuring Message Authenticity and Integrity

19.4 S/MIME

Secure/Multipurpose Internet Mail Extension (S/MIME) is a security enhancement to the MIME Internet email format standard based on technology from RSA Data Security. S/MIME is a complex capability that is defined in a number of documents. The most important documents relevant to S/MIME include the following:

- **RFC 5750, S/MIME Version 3.2 Certificate Handling:** Specifies conventions for X.509 certificate usage by (S/MIME) v3.2.
- **RFC 5751, S/MIME) Version 3.2 Message Specification:** The principal defining document for S/MIME message creation and processing.

- **RFC 4134, Examples of S/MIME Messages:** Gives examples of message bodies formatted using S/MIME.
- **RFC 2634, Enhanced Security Services for S/MIME:** Describes four optional security service extensions for S/MIME.
- **RFC 5652, Cryptographic Message Syntax (CMS):** Describes the Cryptographic Message Syntax (CMS). This syntax is used to digitally sign, digest, authenticate, or encrypt arbitrary message content.
- **RFC 3370, CMS Algorithms:** Describes the conventions for using several cryptographic algorithms with the CMS.
- **RFC 5752, Multiple Signatures in CMS:** Describes the use of multiple, parallel signatures for a message.
- **RFC 1847, Security Multiparts for MIME—Multipart/Signed and Multipart/Encrypted:** Defines a framework within which security services may be applied to MIME body parts. The use of a digital signature is relevant to S/MIME, as explained subsequently.

Operational Description

S/MIME provides for four message-related services: authentication, confidentiality, compression, and email compatibility (Table 19.4). This subsection provides an overview. We then look in more detail at this capability by examining message formats and message preparation.

AUTHENTICATION Authentication is provided by means of a digital signature, using the general scheme discussed in Chapter 13 and illustrated in Figure 13.1. Most commonly RSA with SHA-256 is used. The sequence is as follows:

1. The sender creates a message.
2. SHA-256 is used to generate a 256-bit message digest of the message.
3. The message digest is encrypted with RSA using the sender's private key, and the result is appended to the message. Also appended is identifying

Table 19.4 Summary of S/MIME Services

Function	Typical Algorithm	Typical Action
Digital signature	RSA/SHA-256	A hash code of a message is created using SHA-256. This message digest is encrypted using SHA-256 with the sender's private key and included with the message.
Message encryption	AES-128 with CBC	A message is encrypted using AES-128 with CBC with a one-time session key generated by the sender. The session key is encrypted using RSA with the recipient's public key and included with the message.
Compression	unspecified	A message may be compressed for storage or transmission.
Email compatibility	Radix-64 conversion	To provide transparency for email applications, an encrypted message may be converted to an ASCII string using radix-64 conversion.

information for the signer, which will enable the receiver to retrieve the signer's public key.

4. The receiver uses RSA with the sender's public key to decrypt and recover the message digest.
5. The receiver generates a new message digest for the message and compares it with the decrypted hash code. If the two match, the message is accepted as authentic.

The combination of SHA-256 and RSA provides an effective digital signature scheme. Because of the strength of RSA, the recipient is assured that only the possessor of the matching private key can generate the signature. Because of the strength of SHA-256, the recipient is assured that no one else could generate a new message that matches the hash code and, hence, the signature of the original message.

Although signatures normally are found attached to the message or file that they sign, this is not always the case: Detached signatures are supported. A **detached signature** may be stored and transmitted separately from the message it signs. This is useful in several contexts. A user may wish to maintain a separate signature log of all messages sent or received. A detached signature of an executable program can detect subsequent virus infection. Finally, detached signatures can be used when more than one party must sign a document, such as a legal contract. Each person's signature is independent and therefore is applied only to the document. Otherwise, signatures would have to be nested, with the second signer signing both the document and the first signature, and so on.

CONFIDENTIALITY S/MIME provides confidentiality by encrypting messages. Most commonly AES with a 128-bit key is used, with the cipher block chaining (CBC) mode. The key itself is also encrypted, typically with RSA, as explained below.

As always, one must address the problem of key distribution. In S/MIME, each symmetric key, referred to as a content-encryption key, is used only once. That is, a new key is generated as a random number for each message. Because it is to be used only once, the content-encryption key is bound to the message and transmitted with it. To protect the key, it is encrypted with the receiver's public key. The sequence can be described as follows:

1. The sender generates a message and a random 128-bit number to be used as a content-encryption key for this message only.
2. The message is encrypted using the content-encryption key.
3. The content-encryption key is encrypted with RSA using the recipient's public key and is attached to the message.
4. The receiver uses RSA with its private key to decrypt and recover the content-encryption key.
5. The content-encryption key is used to decrypt the message.

Several observations may be made. First, to reduce encryption time, the combination of symmetric and public-key encryption is used in preference to simply using public-key encryption to encrypt the message directly: Symmetric algorithms are substantially faster than asymmetric ones for a large block of content. Second, the use of the public-key algorithm solves the **session-key** distribution problem, because only

the recipient is able to recover the session key that is bound to the message. Note that we do not need a session-key exchange protocol of the type discussed in Chapter 14, because we are not beginning an ongoing session. Rather, each message is a one-time independent event with its own key. Furthermore, given the store-and-forward nature of electronic mail, the use of handshaking to assure that both sides have the same session key is not practical. Finally, the use of one-time symmetric keys strengthens what is already a strong symmetric encryption approach. Only a small amount of plaintext is encrypted with each key, and there is no relationship among the keys. Thus, to the extent that the public-key algorithm is secure, the entire scheme is secure.

CONFIDENTIALITY AND AUTHENTICATION As Figure 19.3 illustrates, both confidentiality and encryption may be used for the same message. The figure shows a sequence in

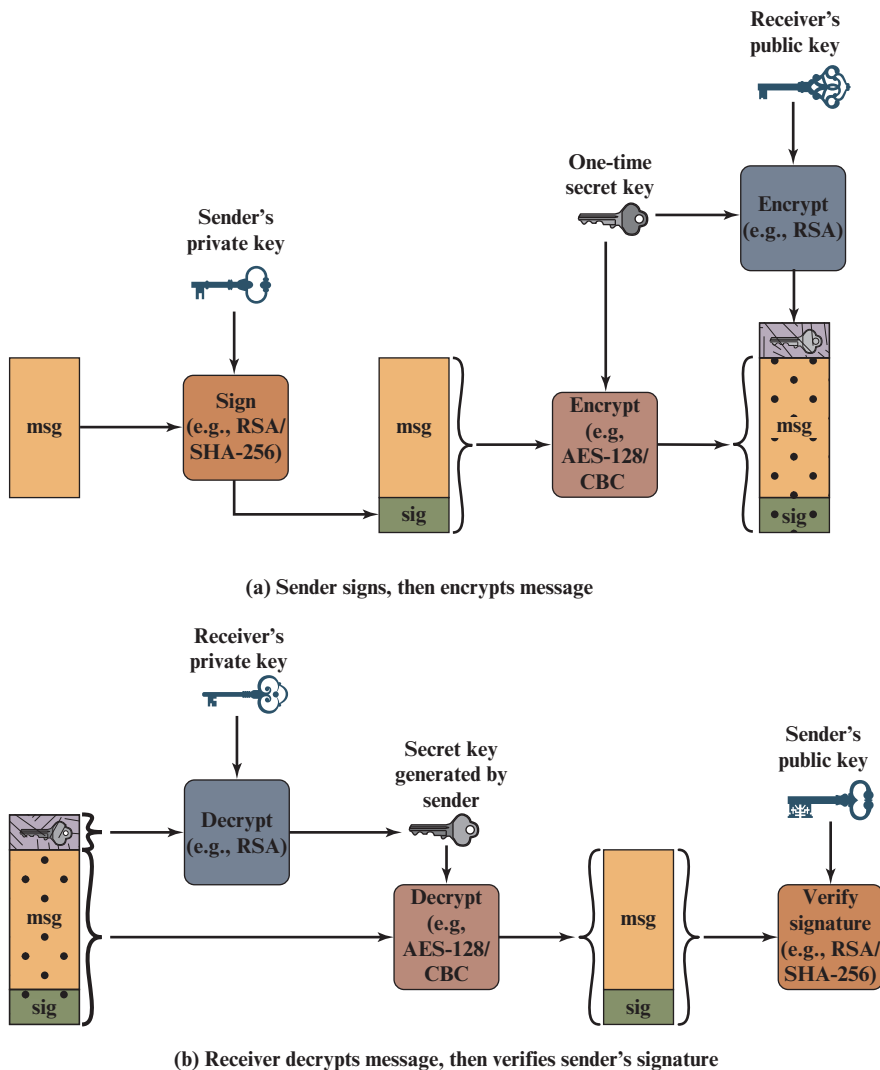

Figure 19.3 Simplified S/MIME Functional Flow

which a signature is generated for the plaintext message and appended to the message. Then the plaintext message and signature are encrypted as a single block using symmetric encryption and the symmetric encryption key is encrypted using public-key encryption.

S/MIME allows the signing and message encryption operations to be performed in either order. If signing is done first, the identity of the signer is hidden by the encryption. Plus, it is generally more convenient to store a signature with a plaintext version of a message. Furthermore, for purposes of third-party verification, if the signature is performed first, a third party need not be concerned with the symmetric key when verifying the signature.

If encryption is done first, it is possible to verify a signature without exposing the message content. This can be useful in a context in which automatic signature verification is desired, as no private key material is required to verify a signature. However, in this case the recipient cannot determine any relationship between the signer and the unencrypted content of the message.

EMAIL COMPATIBILITY When S/MIME is used, at least part of the block to be transmitted is encrypted. If only the signature service is used, then the message digest is encrypted (with the sender's private key). If the confidentiality service is used, the message plus signature (if present) are encrypted (with a one-time symmetric key). Thus, part or all of the resulting block consists of a stream of arbitrary 8-bit octets. However, many electronic mail systems only permit the use of blocks consisting of ASCII text. To accommodate this restriction, S/MIME provides the service of converting the raw 8-bit binary stream to a stream of printable ASCII characters, a process referred to as 7-bit encoding.

The scheme typically used for this purpose is base64 conversion. Each group of three octets of binary data is mapped into four ASCII characters. Base64 is described in RFC 4648 (*The base16, base32, and base64 Data Encodings*).

One noteworthy aspect of the base64 algorithm is that it blindly converts the input stream to base64 format regardless of content, even if the input happens to be ASCII text. Thus, if a message is signed but not encrypted and the conversion is applied to the entire block, the output will be unreadable to the casual observer, which provides a certain level of confidentiality.

RFC 5751 also recommends that even if outer 7-bit encoding is not used, the original MIME content should be 7-bit encoded. The reason for this is that it allows the MIME entity to be handled in any environment without changing it. For example, a trusted gateway might remove the encryption, but not the signature, of a message, and then forward the signed message on to the end recipient so that they can verify the signatures directly. If the transport internal to the site is not 8-bit clean, such as on a wide area network with a single mail gateway, verifying the signature will not be possible unless the original MIME entity was only 7-bit data.

COMPRESSION S/MIME also offers the ability to compress a message. This has the benefit of saving space both for email transmission and for file storage. Compression can be applied in any order with respect to the signing and message encryption operations. RFC 5751 provides the following guidelines:

- Compression of binary encoded encrypted data is discouraged, since it will not yield significant compression. Base64 encrypted data could very well benefit, however.
- If a lossy compression algorithm is used with signing, you will need to compress first, then sign.

S/MIME Message Content Types

S/MIME uses the following message content types, which are defined in RFC 5652, Cryptographic Message Syntax:

- **Data:** Refers to the inner MIME-encoded message content, which may then be encapsulated in a SignedData, EnvelopedData, or CompressedData content type.
- **SignedData:** Used to apply a digital signature to a message.
- **EnvelopedData:** This consists of encrypted content of any type and encrypted-content encryption keys for one or more recipients.
- **CompressedData:** Used to apply data compression to a message.

The Data content type is also used for a procedure known as clear signing. For clear signing, a digital signature is calculated for a MIME-encoded message and the two parts, the message and signature, form a multipart MIME message. Unlike SignedData, which involves encapsulating the message and signature in a special format, clear-signed messages can be read and their signatures verified by email entities that do not implement S/MIME.

The following rules, in the following order, should be followed by a sending agent.

1. If the sending agent has a list of preferred decrypting capabilities from an intended recipient, it SHOULD choose the first (highest preference) capability on the list that it is capable of using.
2. If the sending agent has no such list of capabilities from an intended recipient but has received one or more messages from the recipient, then the outgoing message SHOULD use the same encryption algorithm as was used on the last signed and encrypted message received from that intended recipient.
3. If the sending agent has no knowledge about the decryption capabilities of the intended recipient and is willing to risk that the recipient may not be able to decrypt the message, then the sending agent SHOULD use triple DES.
4. If the sending agent has no knowledge about the decryption capabilities of the intended recipient and is not willing to risk that the recipient may not be able to decrypt the message, then the sending agent MUST use RC2/40.

If a message is to be sent to multiple recipients and a common encryption algorithm cannot be selected for all, then the sending agent will need to send two messages. However, in that case, it is important to note that the security of the message is made vulnerable by the transmission of one copy with lower security.

S/MIME Messages

S/MIME makes use of a number of new MIME content types. All of the new application types use the designation PKCS. This refers to a set of public-key cryptography specifications issued by RSA Laboratories and made available for the S/MIME effort.

We examine each of these in turn after first looking at the general procedures for S/MIME message preparation.

SECURING A MIME ENTITY S/MIME secures a MIME entity with a signature, encryption, or both. A MIME entity may be an entire message (except for the RFC 5322 headers), or if the MIME content type is multipart, then a MIME entity is one or more of the subparts of the message. The MIME entity is prepared according to the normal rules for MIME message preparation. Then the MIME entity plus some security-related data, such as algorithm identifiers and certificates, are processed by S/MIME to produce what is known as a PKCS object. A PKCS object is then treated as message content and wrapped in MIME (provided with appropriate MIME headers). This process should become clear as we look at specific objects and provide examples.

In all cases, the message to be sent is converted to canonical form. In particular, for a given type and subtype, the appropriate canonical form is used for the message content. For a multipart message, the appropriate canonical form is used for each subpart.

The use of transfer encoding requires special attention. For most cases, the result of applying the security algorithm will be to produce an object that is partially or totally represented in arbitrary binary data. This will then be wrapped in an outer MIME message and transfer encoding can be applied at that point, typically base64. However, in the case of a multipart signed message (described in more detail later), the message content in one of the subparts is unchanged by the security process. Unless that content is 7 bit, it should be transfer encoded using base64 or quoted-printable so that there is no danger of altering the content to which the signature was applied.

We now look at each of the S/MIME content types.

ENVELOPEDDATA An application/pkcs7-mime subtype is used for one of four categories of S/MIME processing, each with a unique smime-type parameter. In all cases, the resulting entity, (referred to as an *object*) is represented in a form known as Basic Encoding Rules (BER), which is defined in ITU-T Recommendation X.209. The BER format consists of arbitrary octet strings and is therefore binary data. Such an object should be transfer encoded with base64 in the outer MIME message. We first look at envelopedData.

The steps for preparing an envelopedData MIME entity are:

1. Generate a pseudorandom session key for a particular symmetric encryption algorithm (RC2/40 or triple DES).
2. For each recipient, encrypt the session key with the recipient's public RSA key.
3. For each recipient, prepare a block known as `RecipientInfo` that contains an identifier of the recipient's public-key certificate,¹ an identifier of the algorithm used to encrypt the session key, and the encrypted session key.
4. Encrypt the message content with the session key.

The `RecipientInfo` blocks followed by the encrypted content constitute the `envelopedData`. This information is then encoded into base64. A sample message (excluding the RFC 5322 headers) is given below.

¹This is an X.509 certificate, discussed later in this section.

```

Content-Type: application/pkcs7-mime; smime-type=enveloped-
    data; name=smime.p7m
Content-Transfer-Encoding: base64
Content-Disposition: attachment; filename=smime.p7m

rfvbnj756tbBghyHhHUujhJhjH77n8HHGT9HG4VQpfyF467GhIGfHfYT6
7n8HHGghyHhHUujhJh4VQpfyF467GhIGfHfYGTTrfvbnjT6jH7756tbB9H
f8HHGTrfvhJhjH776tbB9HG4VQbnj7567GhIGfHfYT6ghyHhHUujpfyF4
0GhIGfHfQbnj756YT64V

```

To recover the encrypted message, the recipient first strips off the base64 encoding. Then the recipient's private key is used to recover the session key. Finally, the message content is decrypted with the session key.

SIGNEDDATA The `signedData` `smime-type` can be used with one or more signers. For clarity, we confine our description to the case of a single digital signature. The steps for preparing a `signedData` MIME entity are as follows.

1. Select a message digest algorithm (SHA or MD5).
2. Compute the message digest (hash function) of the content to be signed.
3. Encrypt the message digest with the signer's private key.
4. Prepare a block known as `SignerInfo` that contains the signer's public-key certificate, an identifier of the message digest algorithm, an identifier of the algorithm used to encrypt the message digest, and the encrypted message digest.

The `signedData` entity consists of a series of blocks, including a message digest algorithm identifier, the message being signed, and `SignerInfo`. The `signedData` entity may also include a set of public-key certificates sufficient to constitute a chain from a recognized root or top-level certification authority to the signer. This information is then encoded into base64. A sample message (excluding the RFC 5322 headers) is the following.

```

Content-Type: application/pkcs7-mime; smime-type=signed-
    data; name=smime.p7m
Content-Transfer-Encoding: base64
Content-Disposition: attachment; filename=smime.p7m

567GhIGfHfYT6ghyHhHUujpfyF4f8HHGTrfvhJhjH776tbB9HG4VQbnj7
77n8HHGT9HG4VQpfyF467GhIGfHfYT6rfvbnj756tbBghyHhHUujhJhjH
HUujhJh4VQpfyF467GhIGfHfYGTTrfvbnjT6jH7756tbB9H7n8HHGghyHh
6YT64V0GhIGfHfQbnj75

```

To recover the signed message and verify the signature, the recipient first strips off the base64 encoding. Then the signer's public key is used to decrypt the message digest. The recipient independently computes the message digest and compares it to the decrypted message digest to verify the signature.

CLEAR SIGNING Clear signing is achieved using the multipart content type with a signed subtype. As was mentioned, this signing process does not involve transforming the message to be signed, so that the message is sent “in the clear.” Thus, recipients with MIME capability but not S/MIME capability are able to read the incoming message.

A multipart/signed message has two parts. The first part can be any MIME type but must be prepared so that it will not be altered during transfer from source to destination. This means that if the first part is not 7 bit, then it needs to be encoded using base64 or quoted-printable. Then this part is processed in the same manner as signedData, but in this case an object with signedData format is created that has an empty message content field. This object is a detached signature. It is then transfer encoded using base64 to become the second part of the multipart/signed message. This second part has a MIME content type of application and a subtype of pkcs7-signature. Here is a sample message:

```
Content-Type: multipart/signed;
    protocol="application/pkcs7-signature";
    micalg=sha1; boundary=boundary42
--boundary42
Content-Type: text/plain

This is a clear-signed message.

--boundary42
Content-Type: application/pkcs7-signature; name=smime.p7s
Content-Transfer-Encoding: base64
Content-Disposition: attachment; filename=smime.p7s
ghyHhHUujhJhjH77n8HHGTrfvbnj756tbB9HG4VQpfyF467GhIGfHfYT6
4VQpfyF467GhIGfHfYT6jH77n8HHGghyHhHUujhJh756tbB9HGTrfvbnj
n8HHGTrfvhJhjH776tbB9HG4VQbnj7567GhIGfHfYT6ghyHhHUujpfyF4
7GhIGfHfYT64VQbnj756
--boundary42--
```

The protocol parameter indicates that this is a two-part clear-signed entity. The micalg parameter indicates the type of message digest used. The receiver can verify the signature by taking the message digest of the first part and comparing this to the message digest recovered from the signature in the second part.

REGISTRATION REQUEST Typically, an application or user will apply to a certification authority for a public-key certificate. The application/pkcs10 S/MIME entity is used to transfer a certification request. The certification request includes certificationRequestInfo block, followed by an identifier of the public-key encryption algorithm, followed by the signature of the certificationRequestInfo block, made using the sender’s private key. The certificationRequestInfo block includes a name of the certificate subject (the entity whose public key is to be certified) and a bit-string representation of the user’s public key.

CERTIFICATES-ONLY MESSAGE A message containing only certificates or a certificate revocation list (CRL) can be sent in response to a registration request. The message is an application/pkcs7-mime type/subtype with an smime-type parameter of degenerate. The steps involved are the same as those for creating a signedData message, except that there is no message content and the signerInfo field is empty.

S/MIME Certificate Processing

S/MIME uses public-key certificates that conform to version 3 of X.509 (see Chapter 14). S/MIME managers and/or users must configure each client with a list of trusted keys and with certificate revocation lists. That is, the responsibility is local for maintaining the certificates needed to verify incoming signatures and to encrypt outgoing messages. On the other hand, the certificates are signed by certification authorities.

USER AGENT ROLE An S/MIME user has several key management functions to perform.

- **Key generation:** The user of some related administrative utility (e.g., one associated with LAN management) **MUST** be capable of generating separate Diffie–Hellman and DSS key pairs and **SHOULD** be capable of generating RSA key pairs. Each key pair **MUST** be generated from a good source of nondeterministic random input and be protected in a secure fashion. A user agent **SHOULD** generate RSA key pairs with a length in the range of 768 to 1024 bits and **MUST NOT** generate a length of less than 512 bits.
- **Registration:** A user’s public key must be registered with a certification authority in order to receive an X.509 public-key certificate.
- **Certificate storage and retrieval:** A user requires access to a local list of certificates in order to verify incoming signatures and to encrypt outgoing messages. Such a list could be maintained by the user or by some local administrative entity on behalf of a number of users.

Enhanced Security Services

RFC 2634 defines four enhanced security services for S/MIME:

- **Signed receipts:** A signed receipt may be requested in a SignedData object. Returning a signed receipt provides proof of delivery to the originator of a message and allows the originator to demonstrate to a third party that the recipient received the message. In essence, the recipient signs the entire original message plus the original (sender’s) signature and appends the new signature to form a new S/MIME message.
- **Security labels:** A security label may be included in the authenticated attributes of a SignedData object. A security label is a set of security information regarding the sensitivity of the content that is protected by S/MIME encapsulation. The labels may be used for access control, by indicating which users are permitted access to an object. Other uses include priority (secret, confidential, restricted, and so on) or role based, describing which kind of people can see the information (e.g., patient’s health-care team, medical billing agents).

- **Secure mailing lists:** When a user sends a message to multiple recipients, a certain amount of per-recipient processing is required, including the use of each recipient's public key. The user can be relieved of this work by employing the services of an S/MIME Mail List Agent (MLA). An MLA can take a single incoming message, perform the recipient-specific encryption for each recipient, and forward the message. The originator of a message need only send the message to the MLA with encryption performed using the MLA's public key.
- **Signing certificates:** This service is used to securely bind a sender's certificate to their signature through a signing certificate attribute.

19.5 DNSSEC

DNS Security Extensions (DNSSEC) are used by several protocols that provide email security. This section provides a brief overview of the Domain Name System (DNS) and then looks at DNSSEC.

Domain Name System

DNS is a directory lookup service that provides a mapping between the name of a host on the Internet and its numeric IP address. DNS is essential to the functioning of the Internet. The DNS is used by MUAs and MTAs to find the address of the next hop server for mail delivery. Sending MTAs query DNS for the Mail Exchange Resource Record (MX RR) of the recipient's domain (the right hand side of the "@" symbol) in order to find the receiving MTA to contact.

Four elements comprise the DNS:

- **Domain name space:** DNS uses a tree-structured name space to identify resources on the Internet.
- **DNS database:** Conceptually, each node and leaf in the name space tree structure names a set of information (e.g., IP address, name server for this domain name) that is contained in resource record. The collection of all RRs is organized into a distributed database.
- **Name servers:** These are server programs that hold information about a portion of the domain name tree structure and the associated RRs.
- **Resolvers:** These are programs that extract information from name servers in response to client requests. A typical client request is for an IP address corresponding to a given domain name.

THE DNS DATABASE DNS is based on a hierarchical database containing **resource records (RRs)** that include the name, IP address, and other information about hosts. The key features of the database are as follows:

- **Variable-depth hierarchy for names:** DNS allows essentially unlimited levels and uses the period (.) as the level delimiter in printed names, as described earlier.
- **Distributed database:** The database resides in DNS servers scattered throughout the Internet.

Table 19.5 Resource Record Types

Type	Description
A	A host address. This RR type maps the name of a system to its IPv4 address. Some systems (e.g., routers) have multiple addresses, and there is a separate RR for each.
AAAA	Similar to A type, but for IPv6 addresses.
CNAME	Canonical name. Specifies an alias name for a host and maps this to the canonical (true) name.
HINFO	Host information. Designates the processor and operating system used by the host.
MINFO	Mailbox or mail list information. Maps a mailbox or mail list name to a host name.
MX	Mail exchange. Identifies the system(s) via which mail to the queried domain name should be relayed.
NS	Authoritative name server for this domain.
PTR	Domain name pointer. Points to another part of the domain name space.
SOA	Start of a zone of authority (which part of naming hierarchy is implemented). Includes parameters related to this zone.
SRV	For a given service provides name of server or servers in domain that provide that service.
TXT	Arbitrary text. Provides a way to add text comments to the database.
WKS	Well-known services. May list the application services available at this host.

- **Distribution controlled by the database:** The DNS database is divided into thousands of separately managed zones, which are managed by separate administrators. Distribution and update of records is controlled by the database software.

Using this database, DNS servers provide a name-to-address directory service for network applications that need to locate specific servers. For example, every time an email message is sent or a Web page is accessed, there must be a DNS name lookup to determine the IP address of the email server or Web server.

Table 19.5 lists the various types of resource records.

DNS OPERATION DNS operation typically includes the following steps (Figure 19.4):

1. A user program requests an IP address for a domain name.
2. A resolver module in the local host or local ISP queries a local name server in the same domain as the resolver.
3. The local name server checks to see if the name is in its local database or cache, and, if so, returns the IP address to the requestor. Otherwise, the name server queries other available name servers, if necessary going to the root server, as explained subsequently.
4. When a response is received at the local name server, it stores the name/address mapping in its local cache and may maintain this entry for the amount of time specified in the time-to-live field of the retrieved RR.
5. The user program is given the IP address or an error message.

The distributed DNS database that supports the DNS functionality must be updated frequently because of the rapid and continued growth of the Internet. Further, the DNS must cope with dynamic assignment of IP addresses, such as is

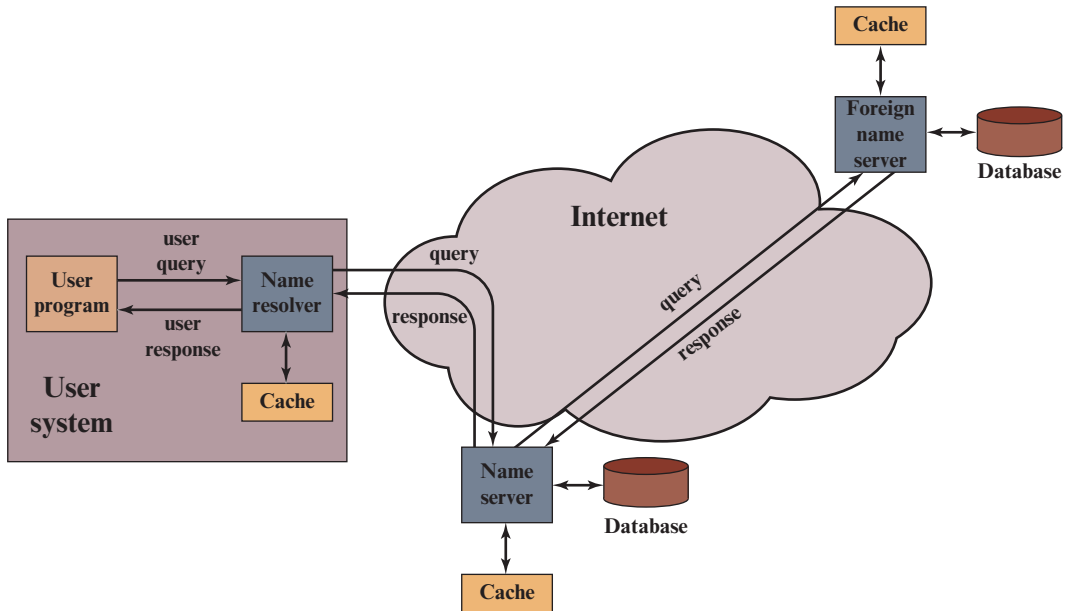

Figure 19.4 DNS Name Resolution

done for home DSL users by their ISP. Accordingly, dynamic updating functions for DNS have been defined. In essence, DNS name servers automatically send out updates to other relevant name servers as conditions warrant.

DNS Security Extensions

DNSSEC provides end-to-end protection through the use of digital signatures that are created by responding zone administrators and verified by a recipient's resolver software. In particular, DNSSEC avoids the need to trust intermediate name servers and resolvers that cache or route the DNS records originating from the responding zone administrator before they reach the source of the query. DNSSEC consists of a set of new resource record types and modifications to the existing DNS protocol, and is defined in the following documents:

- **RFC 4033, DNS Security Introduction and Requirements:** Introduces the DNS security extensions and describes their capabilities and limitations. The document also discusses the services that the DNS security extensions do and do not provide.
- **RFC 4034, Resource Records for the DNS Security Extensions:** Defines four new resource records that provide security for DNS.
- **RFC 4035, Protocol Modifications for the DNS Security Extensions:** Defines the concept of a signed zone, along with the requirements for serving and resolving by using DNSSEC. These techniques allow a security-aware resolver to authenticate both DNS resource records and authoritative DNS error indications.

DNSSEC OPERATION In essence, DNSSEC is designed to protect DNS clients from accepting forged or altered DNS resource records. It does this by using digital signatures to provide:

- **Data origin authentication:** Ensures that data has originated from the correct source.
- **Data integrity verification:** Ensures that the content of a RR has not been modified.

The DNS zone administrator digitally signs every Resource Record set (RRset) in the zone, and publishes this collection of digital signatures, along with the zone administrator's public key, in the DNS itself. In DNSSEC, trust in the public key (for signature verification) of the source is established not by going to a third party or a chain of third parties (as in public key infrastructure [PKI] chaining), but by starting from a trusted zone (such as the root zone) and establishing the chain of trust down to the current source of response through successive verifications of signature of the public key of a child by its parent. The public key of the trusted zone is called the *trust anchor*.

RESOURCE RECORDS FOR DNSSEC RFC 4034 defines four new DNS resource records:

- **DNSKEY:** Contains a public key.
- **RRSIG:** A resource record digital signature.
- **NSEC:** Authenticated denial of existence record.
- **DS:** Delegation signer.

An RRSIG is associated with each RRset, where an RRset is the set of resource records that have the same label, class, and type. When a client requests data, an RRset is returned, together with the associated digital signature in an RRSIG record. The client obtains the relevant DNSKEY public key and verifies the signature for this RRset.

DNSSEC depends on establishing the authenticity of the DNS hierarchy leading to the domain name in question, and thus its operation depends on beginning the use of cryptographic digital signatures in the root zone. The DS resource record facilitates key signing and authentication between DNS zones to create an authentication chain, or trusted sequence of signed data, from the root of the DNS tree down to a specific domain name. To secure all DNS lookups, including those for non-existent domain names and record types, DNSSEC uses the NSEC resource record to authenticate negative responses to queries. NSEC is used to identify the range of DNS names or resource record types that do not exist among the sequence of domain names in a zone.

19.6 DNS-BASED AUTHENTICATION OF NAMED ENTITIES

DANE is a protocol to allow X.509 certificates, commonly used for Transport Layer Security (TLS), to be bound to DNS names using DNSSEC. It is proposed in RFC 6698 as a way to authenticate TLS client and server entities without a certificate authority (CA).

The rationale for DANE is the vulnerability of the use of CAs in a global PKI system. Every browser developer and operating system supplier maintains a list of CA root certificates as trust anchors. These are called the software's root certificates and are stored in its root certificate store. The PKIX procedure allows a certificate recipient to trace a certificate back to the root. So long as the root certificate remains trustworthy, and the authentication concludes successfully, the client can proceed with the connection.

However, if any of the hundreds of CAs operating on the Internet is compromised, the effects can be widespread. The attacker can obtain the CA's private key, get issued certificates under a false name, or introduce new bogus root certificates into a root certificate store. There is no limitation of scope for the global PKI and a compromise of a single CA damages the integrity of the entire PKI system. In addition, some CAs have engaged in poor security practices. For example, some CAs have issued wildcard certificates that allow the holder to issue sub-certificates for any domain or entity, anywhere in the world.

The purpose of DANE is to replace reliance on the security of the CA system with reliance on the security provided by DNSSEC. Given that the DNS administrator for a domain name is authorized to give identifying information about the zone, it makes sense to allow that administrator to also make an authoritative binding between the domain name and a certificate that might be used by a host at that domain name.

TLSA Record

DANE defines a new DNS record type, TLSA, that can be used for a secure method of authenticating SSL/TLS certificates. The TLSA provides for:

- Specifying constraints on which CA can vouch for a certificate, or which specific PKIX end-entity certificate is valid.
- Specifying that a service certificate or a CA can be directly authenticated in the DNS itself.

The TLSA RR enables certificate issue and delivery to be tied to a given domain. A server domain owner creates a TLSA resource record that identifies the certificate and its public key. When a client receives an X.509 certificate in the TLS negotiation, it looks up the TLSA RR for that domain and matches the TLSA data against the certificate as part of the client's certificate validation procedure.

Figure 19.5 shows the format of a TLSA RR as it is transmitted to a requesting entity. It contains four fields. The **Certificate Usage** field defines four different usage models, to accommodate users who require different forms of authentication. The usage models are:

- **PKIX-TA (CA constraint):** Specifies which CA should be trusted to authenticate the certificate for the service. This usage model limits which CA can be used to issue certificates for a given service on a host. The server certificate chain must pass PKIX validation that terminates with a trusted root certificate stored in the client.
- **PKIX-EE (service certificate constraint):** Defines which specific end entity service certificate should be trusted for the service. This usage model limits which end entity certificate can be used by a given service on a host. The server certificate chain must pass PKIX validation that terminates with a trusted root certificate stored in the client.

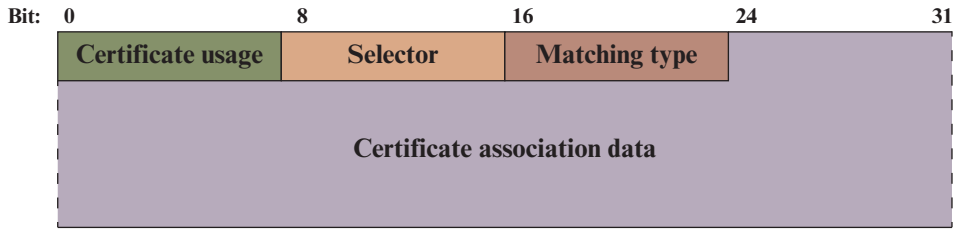

Figure 19.5 TLSA RR Transmission Format

- **DANE-TA (trust anchor assertion):** Specifies a domain-operated CA to be used as a trust anchor. This usage model allows a domain name administrator to specify a new trust anchor—for example, if the domain issues its own certificates under its own CA that is not expected to be in the end users’ collection of trust anchors. The server certificate chain is self-issued and does not need to verify against a trusted root stored in the client.
- **DANE-EE (domain-issued certificate):** Specifies a domain-operated CA to be used as a trust anchor. This certificate usage allows a domain name administrator to issue certificates for a domain without involving a third-party CA. The server certificate chain is self-issued and does not need to verify against a trusted root stored in the client.

The first two usage models are designed to co-exist with and strengthen the public CA system. The final two usage models operate without the use of public CAs.

The **Selector** field indicates whether the full certificate will be matched or just the value of the public key. The match is made between the certificate presented in TLS negotiation and the certificate in the TLSA RR. The **Matching Type** field indicates how the match of the certificate is made. The options are exact match, SHA-256 hash match, or SHA-512 hash match. The **Certificate Association Data** is the raw certificate data in hex format.

Use of DANE for SMTP

DANE can be used in conjunction with SMTP over TLS, as provided by STARTTLS, to more fully secure email delivery. DANE can authenticate the certificate of the SMTP submission server that the user’s mail client (MUA) communicates with. It can also authenticate the TLS connections between SMTP servers (MTAs). The use of DANE with SMTP is documented in an Internet Draft (*SMTP Security via Opportunistic DANE TLS*, draft-ietf-dane-smtp-with-dane-19, May 29, 2015).

As discussed in Section 19.1, SMTP can use the STARTTLS extension to run SMTP over TLS, so that the entire email message plus SMTP envelope are encrypted. This is done opportunistically, that is, if both sides support STARTTLS. Even when TLS is used to provide confidentiality, it is vulnerable to attack in the following ways:

- Attackers can strip away the TLS capability advertisement and downgrade the connection to not use TLS.
- TLS connections are often unauthenticated (e.g., the use of self-signed certificates as well as mismatched certificates is common).

DANE can address both these vulnerabilities. A domain can use the presence of the TLSA RR as an indicator that encryption must be performed, thus preventing malicious downgrade. A domain can authenticate the certificate used in the TLS connection setup using a DNSSEC-signed TLSA RR.

Use of DNSSEC for S/MIME

DNSSEC can be used in conjunction with S/MIME to more fully secure email delivery, in a manner similar to the DANE functionality. This use is documented in an Internet Draft (*Using Secure DNS to Associate Certificates with Domain Names for S/MIME*, draft-ietf-dane-smime-09, August 27, 2015), which proposes a new SMIMEA DNS RR. The purpose of the SMIMEA RR is to associate certificates with DNS domain names.

As discussed in Section 19.4, S/MIME messages often contain certificates that can assist in authenticating the message sender and can be used in encrypting messages sent in reply. This feature requires that the receiving MUA validate the certificate associated with the purported sender. SMIMEA RRs can provide a secure means of doing this validation.

In essence, the SMIMEA RR will have the same format and content as the TLSA RR, with the same functionality. The difference is that it is geared to the needs of MUAs in dealing with domain names as specified in email addresses in the message body, rather than domain names specified in the outer SMTP envelope.

19.7 SENDER POLICY FRAMEWORK

SPF is the standardized way for a sending domain to identify and assert the mail senders for a given domain. The problem that SPF addresses is the following: With the current email infrastructure, any host can use any domain name for each of the various identifiers in the mail header, not just the domain name where the host is located. Two major drawbacks of this freedom are:

- It is a major obstacle to reducing unsolicited bulk email (UBE), also known as spam. It makes it difficult for mail handlers to filter out emails on the basis of known UBE sources.
- ADMDs (see Section 19.1) are understandably concerned about the ease with which other entities can make use of their domain names, often with malicious intent.

RFC 7208 defines the SPF. It provides a protocol by which ADMDs can authorize hosts to use their domain names in the “MAIL FROM” or “HELO” identities. Compliant ADMDs publish Sender Policy Framework (SPF) records in the DNS specifying which hosts are permitted to use their names, and compliant mail receivers use the published SPF records to test the authorization of sending Mail Transfer Agents (MTAs) using a given “HELO” or “MAIL FROM” identity during a mail transaction.

```

S: 220 foo.com Simple Mail Transfer Service Ready
C: HELO mta.example.net
S: 250 OK
C: MAIL FROM:<alice@example.org>
S: 250 OK
C: RCPT TO:<Jones@foo.com>
S: 250 OK
C: DATA
S: 354 Start mail input; end with <crLf>.<crLf>
C: To: bob@foo.com
C: From: alice.sender@example.net
C: Date: Today
C: Subject: Meeting Today
. . .

```

Figure 19.6 Example in which SMTP Envelope Header Does Not Match Message Header

SPF works by checking a sender's IP address against the policy encoded in any SPF record found at the sending domain. The sending domain is the domain used in the SMTP connection, not the domain indicated in the message header as displayed in the MUA. This means that SPF checks can be applied before the message content is received from the sender.

Figure 19.6 is an example in which SPF would come into play. Assume that the sender's IP address is 192.168.0.1. The message arrives from the MTA with domain `mta.example.net`. The sender uses the `MAIL FROM` tag of `alice@example.org`, indicating that the message originates in the `example.org` domain. But the message header specifies `alice.sender@example.net`. The receiver uses SPF to query for the SPF RR that corresponds to `example.com` to check if the IP address 192.168.0.1 is listed as a valid sender, and then takes appropriate action based on the results of checking the RR.

SPF on the Sender Side

A sending domain needs to identify all the senders for a given domain and add that information into the DNS as a separate resource record. Next, the sending domain encodes the appropriate policy for each sender using the SPF syntax. The encoding is done in a `TXT` DNS resource record as a list of mechanisms and modifiers. Mechanisms are used to define an IP address or range of addresses to be matched, and modifiers indicate the policy for a given match. Table 19.6 lists the most important mechanisms and modifiers used in SPF.

The SPF syntax is fairly complex and can express complex relationships between senders. For more detail, see RFC 7208.

Table 19.6 Common SPF Mechanisms and Modifiers

Tag	Description
ip4	Specifies an IPv4 address or range of addresses that are authorized senders for a domain.
ip6	Specifies an IPv6 address or range of addresses that are authorized senders for a domain.
mx	Asserts that the listed hosts for the Mail Exchange RRs are also valid senders for the domain.
include	Lists another domain where the receiver should look for an SPF RR for further senders. This can be useful for large organizations with many domains or sub-domains that have a single set of shared senders. The include mechanism is recursive, in that the SPF check in the record found is tested in its entirety before proceeding. It is not simply a concatenation of the checks.
all	Matches every IP address that has not otherwise been matched.

(a) SPF Mechanisms

Modifier	Description
+	The given mechanism check must pass. This is the default mechanism and does not need to be explicitly listed.
-	The given mechanism is not allowed to send email on behalf of the domain.
~	The given mechanism is in transition and if an email is seen from the listed host/IP address, then it should be accepted but marked for closer inspection.
?	The SPF RR explicitly states nothing about the mechanism. In this case, the default behavior is to accept the email. (This makes it equivalent to ‘ + ’ unless some sort of discrete or aggregate message review is conducted.)

(b) SPF Mechanism Modifiers

SPF on the Receiver Side

If SPF is implemented at a receiver, the SPF entity uses the SMTP envelope MAIL FROM: address domain and the IP address of the sender to query an SPF TXT RR. The SPF checks can be started before the body of the email message is received, which may result in blocking the transmission of the email content. Alternatively, the entire message can be absorbed and buffered until all the checks are finished. In either case, checks must be completed before the mail message is sent to the end user’s inbox.

The checking involves the following rules:

1. If no SPF TXT RR is returned, the default behavior is to accept the message.
2. If the SPF TXT RR has formatting errors, the default behavior is to accept the message.

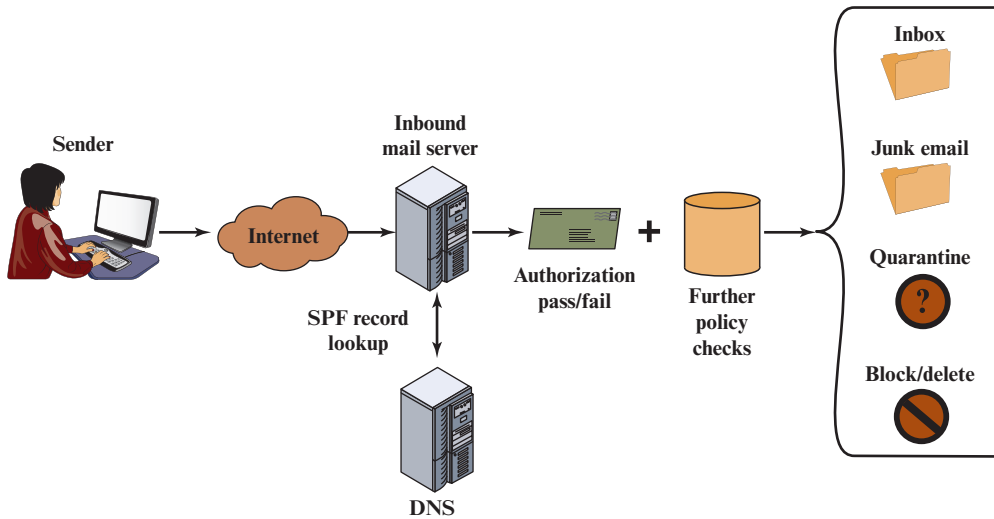

Figure 19.7 Sender Policy Framework Operation

3. Otherwise the mechanisms and modifiers in the RR are used to determine disposition of the email message.

Figure 19.7 illustrates SPF operation.

19.8 DOMAINKEYS IDENTIFIED MAIL

DomainKeys Identified Mail (DKIM) is a specification for cryptographically signing email messages, permitting a signing domain to claim responsibility for a message in the mail stream. Message recipients (or agents acting in their behalf) can verify the signature by querying the signer's domain directly to retrieve the appropriate public key and thereby can confirm that the message was attested to by a party in possession of the private key for the signing domain. DKIM is an Internet Standard (RFC 6376: *DomainKeys Identified Mail (DKIM) Signatures*). DKIM has been widely adopted by a range of email providers, including corporations, government agencies, gmail, Yahoo!, and many Internet Service Providers (ISPs).

Email Threats

RFC 4686 (*Analysis of Threats Motivating DomainKeys Identified Mail*) describes the threats being addressed by DKIM in terms of the characteristics, capabilities, and location of potential attackers.

CHARACTERISTICS RFC 4686 characterizes the range of attackers on a spectrum of three levels of threat.

1. At the low end are attackers who simply want to send email that a recipient does not want to receive. The attacker can use one of a number of commercially available tools that allow the sender to falsify the origin address of messages. This makes it difficult for the receiver to filter spam on the basis of originating address or domain.
2. At the next level are professional senders of bulk spam mail. These attackers often operate as commercial enterprises and send messages on behalf of third parties. They employ more comprehensive tools for attack, including Mail Transfer Agents (MTAs) and registered domains and networks of compromised computers (zombies), to send messages and (in some cases) to harvest addresses to which to send.
3. The most sophisticated and financially motivated senders of messages are those who stand to receive substantial financial benefit, such as from an email-based fraud scheme. These attackers can be expected to employ all of the above mechanisms and additionally may attack the Internet infrastructure itself, including DNS cache-poisoning attacks and IP routing attacks.

CAPABILITIES RFC 4686 lists the following as capabilities that an attacker might have.

1. Submit messages to MTAs and Message Submission Agents (MSAs) at multiple locations in the Internet.
2. Construct arbitrary Message Header fields, including those claiming to be mailing lists, resenders, and other mail agents.
3. Sign messages on behalf of domains under their control.
4. Generate substantial numbers of either unsigned or apparently signed messages that might be used to attempt a denial-of-service attack.
5. Resend messages that may have been previously signed by the domain.
6. Transmit messages using any envelope information desired.
7. Act as an authorized submitter for messages from a compromised computer.
8. Manipulation of IP routing. This could be used to submit messages from specific IP addresses or difficult-to-trace addresses, or to cause diversion of messages to a specific domain.
9. Limited influence over portions of DNS using mechanisms such as cache poisoning. This might be used to influence message routing or to falsify advertisements of DNS-based keys or signing practices.
10. Access to significant computing resources, for example, through the conscription of worm-infected “zombie” computers. This could allow the “bad actor” to perform various types of brute-force attacks.
11. Ability to eavesdrop on existing traffic, perhaps from a wireless network.

LOCATION DKIM focuses primarily on attackers located outside of the administrative units of the claimed originator and the recipient. These administrative units frequently correspond to the protected portions of the network adjacent to the originator and recipient. It is in this area that the trust relationships required for authenticated message submission do not exist and do not scale adequately to be practical. Conversely, within these administrative units, there are other mechanisms (such as authenticated message submission) that are easier to deploy and more likely to be used than DKIM. External bad actors are usually attempting to exploit the “any-to-any” nature of email that motivates most recipient MTAs to accept messages from anywhere for delivery to their local domain. They may generate messages without signatures, with incorrect signatures, or with correct signatures from domains with little traceability. They may also pose as mailing lists, greeting cards, or other agents that legitimately send or resend messages on behalf of others.

DKIM Strategy

DKIM is designed to provide an email authentication technique that is transparent to the end user. In essence, a user’s email message is signed by a private key of the administrative domain from which the email originates. The signature covers all of the content of the message and some of the RFC 5322 message headers. At the receiving end, the MDA can access the corresponding public key via a DNS and verify the signature, thus authenticating that the message comes from the claimed administrative domain. Thus, mail that originates from somewhere else but claims to come from a given domain will not pass the authentication test and can be rejected. This approach differs from that of S/MIME, which use the originator’s private key to sign the content of the message. The motivation for DKIM is based on the following reasoning:

1. S/MIME depends on both the sending and receiving users employing S/MIME. For almost all users, the bulk of incoming mail does not use S/MIME, and the bulk of the mail the user wants to send is to recipients not using S/MIME.
2. S/MIME signs only the message content. Thus, RFC 5322 header information concerning origin can be compromised.
3. DKIM is not implemented in client programs (MUAs) and is therefore transparent to the user; the user need not take any action.
4. DKIM applies to all mail from cooperating domains.
5. DKIM allows good senders to prove that they did send a particular message and to prevent forgers from masquerading as good senders.

Figure 19.8 is a simple example of the operation of DKIM. We begin with a message generated by a user and transmitted into the MHS to an MSA that is within the user’s administrative domain. An email message is generated by an email client program. The content of the message, plus selected RFC 5322 headers, is signed by the email provider using the provider’s private key. The signer is associated with a

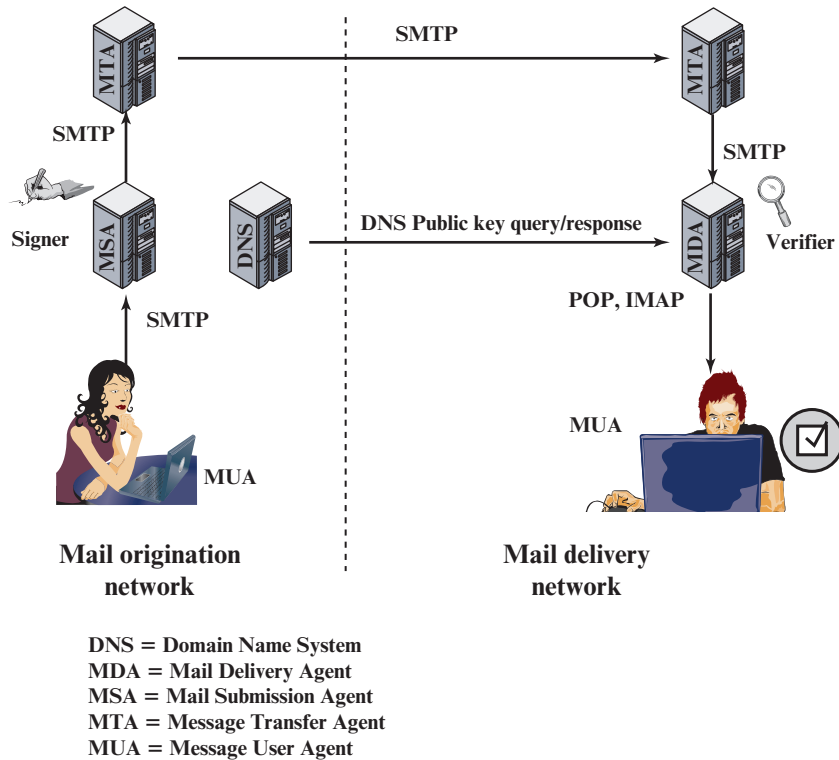

Figure 19.8 Simple Example of DKIM Deployment

domain, which could be a corporate local network, an ISP, or a public email facility such as gmail. The signed message then passes through the Internet via a sequence of MTAs. At the destination, the MDA retrieves the public key for the incoming signature and verifies the signature before passing the message on to the destination email client. The default signing algorithm is RSA with SHA-256. RSA with SHA-1 also may be used.

DKIM Functional Flow

Figure 19.9 provides a more detailed look at the elements of DKIM operation. Basic message processing is divided between a signing Administrative Management Domain (ADMD) and a verifying ADMD. At its simplest, this is between the originating ADMD and the delivering ADMD, but it can involve other ADMDs in the handling path.

Signing is performed by an authorized module within the signing ADMD and uses private information from a Key Store. Within the originating ADMD, this might be performed by the MUA, MSA, or an MTA. Verifying is performed by an authorized module within the verifying ADMD. Within a delivering ADMD, verifying might be performed by an MTA, MDA or MUA. The module verifies the signature or determines whether a particular signature was required. Verifying the signature uses public information from the Key Store. If the signature passes, reputation information is used to assess the signer

```

message-id:subject :from:to:content-type:
content-transfer-encoding;
bh=5mZvQDyCRuyLb1Y28K4zgS2MPOemFTtoDBgvbJ
7GO90s=;
b=PcUvPSDygb4ya5Dyj1rbZGp/VyRiScuaz7TTG
J5qW5slM+klzv6kcfYdGDHzEVJW+Z
FetuPff1ETOVhELtwH0zjSccOyPkeIblOf6gILO
bm3DDRm3Ys1/FVrbhVO1A+/jH9Aei
uIIw/5iFnRbSH6qPDVv/beDQqAWQfA/wF7O5k=

```

Before a message is signed, a process known as canonicalization is performed on both the header and body of the RFC 5322 message. Canonicalization is necessary to deal with the possibility of minor changes in the message made en route, including character encoding, treatment of trailing white space in message lines, and the “folding” and “unfolding” of header lines. The intent of canonicalization is to make a minimal transformation of the message (for the purpose of signing; the message itself is not changed, so the canonicalization must be performed again by the verifier) that will give it its best chance of producing the same canonical value at the receiving end. DKIM defines two header canonicalization algorithms (“simple” and “relaxed”) and two for the body (with the same names). The simple algorithm tolerates almost no modification, while the relaxed algorithm tolerates common modifications.

The signature includes a number of fields. Each field begins with a tag consisting of a tag code followed by an equals sign and ends with a semicolon. The fields include the following:

- **v=** DKIM version/
- **a=** Algorithm used to generate the signature; must be either `rsa-sha1` or `rsa-sha256`
- **c=** Canonicalization method used on the header and the body.
- **d=** A domain name used as an identifier to refer to the identity of a responsible person or organization. In DKIM, this identifier is called the Signing Domain Identifier (SDID). In our example, this field indicates the sender is using a gmail address.
- **s=** In order that different keys may be used in different circumstances for the same signing domain (allowing expiration of old keys, separate departmental signing, or the like), DKIM defines a selector (a name associated with a key) that is used by the verifier to retrieve the proper key during signature verification.
- **h=** Signed Header fields. A colon-separated list of header field names that identify the header fields presented to the signing algorithm. Note that in our example above, the signature covers the domainkey-signature field. This refers to an older algorithm (since replaced by DKIM) that is still in use.
- **bh=** The hash of the canonicalized body part of the message. This provides additional information for diagnosing signature verification failures.
- **b=** The signature data in base64 format; this is the encrypted hash code.

19.9 DOMAIN-BASED MESSAGE AUTHENTICATION, REPORTING, AND CONFORMANCE

Domain-Based Message Authentication, Reporting, and Conformance (DMARC) allows email senders to specify policy on how their mail should be handled, the types of reports that receivers can send back, and the frequency those reports should be sent. It is defined in RFC 7489 (*Domain-based Message Authentication, Reporting, and Conformance*, March 2015).

DMARC works with SPF and DKIM. SPF and DKIM enable senders to advise receivers, via DNS, whether mail purporting to come from the sender is valid, and whether it should be delivered, flagged, or discarded. However, neither SPF nor DKIM include a mechanism to tell receivers if SPF or DKIM are in use, nor do they have feedback mechanism to inform senders of the effectiveness of the anti-spam techniques. For example, if a message arrives at a receiver without a DKIM signature, DKIM provides no mechanism to allow the receiver to learn if the message is authentic but was sent from a sender that did not implement DKIM, or if the message is a spoof. DMARC addresses these issues essentially by standardizing how email receivers perform email authentication using SPF and DKIM mechanisms.

Identifier Alignment

DKIM, SPF, and DMARC authenticate various aspects of an individual message. DKIM authenticates the domain that affixed a signature to the message. SPF focuses on the SMTP envelope, defined in RFC 5321. It can authenticate either the domain that appears in the MAIL FROM portion of the SMTP envelope or the HELO domain, or both. These may be different domains, and they are typically not visible to the end user.

DMARC authentication deals with the From domain in the message header, as defined in RFC 5322. This field is used as the central identity of the DMARC mechanism because it is a required message header field and therefore guaranteed to be present in compliant messages, and most MUAs represent the RFC 5322 From field as the originator of the message and render some or all of this header field's content to end users. The email address in this field is the one used by end users to identify the source of the message and therefore is a prime target for abuse.

DMARC requires that From address match (be aligned with) an Authenticated Identifier from DKIM or SPF. In the case of DKIM, the match is made between the DKIM signing domain and the From domain. In the case of SPF, the match is between the SPF-authenticated domain and the From domain.

DMARC on the Sender Side

A mail sender that uses DMARC must also use SPF or DKIM, or both. The sender posts a DMARC policy in the DNS that advises receivers on how to treat messages that purport to originate from the sender's domain. The policy is in the form of a DNS TXT resource record. The sender also needs to establish email addresses to receive aggregate and forensic reports. As these email addresses are published

Table 19.7 DMARC Tag and Value Descriptions

Tag (Name)	Description
v= (Version)	Version field that must be present as the first element. By default the value is always DMARC1 .
p= (Policy)	Mandatory policy field. May take values none or quarantine or reject . This allows for a gradually tightening policy where the sender domain recommends no specific action on mail that fails DMARC checks (p= none), through treating failed mail as suspicious (p= quarantine), to rejecting all failed mail (p= reject), preferably at the SMTP transaction stage.
aspf= (SPF Policy)	Values are r (default) for relaxed and s for strict SPF domain enforcement. Strict alignment requires an exact match between the From address domain and the (passing) SPF check must exactly match the MailFrom address (HELO address). Relaxed requires that only the From and MailFrom address domains be in alignment. For example, the MailFrom address domain smtp.example.org and the From address announce@example.org are in alignment, but not a strict match.
adkim= (DKIM Policy)	Optional. Values are r (default) for relaxed and s for strict DKIM domain enforcement. Strict alignment requires an exact match between the From domain in the message header and the DKIM domain presented in the (d= DKIM), tag. Relaxed requires only that the domain part is in alignment (as in aspf).
fo= (Failure reporting options)	Optional. Ignore if a ruf argument is not also present. Value 0 indicates the receiver should generate a DMARC failure report if all underlying mechanisms fail to produce an aligned pass result. Value 1 means generate a DMARC failure report if any underlying mechanism produces something other than an aligned pass result. Other possible values are d (generate a DKIM failure report if a signature failed evaluation), and s (generate an SPF failure report if the message failed SPF evaluation). These values are not exclusive and may be combined.
ruf=	Optional, but requires the fo argument to be present. Lists a series of URIs (currently just mailto:<emailaddress>) that list where to send forensic feedback reports. This is for reports on message-specific failures.
rua=	Optional list of URIs (like in ruf= , using the mailto: URI) listing where to send aggregate feedback back to the sender. These reports are sent based on the interval requested using the ri= option with a default of 86400 seconds if not listed.
ri= (Reporting interval)	Optional with the default value of 86400 seconds. The value listed is the reporting interval desired by the sender.
pct= (Percent)	Optional with the default value of 100 . Expresses the percentage of a sender's mail that should be subject to the given DMARC policy. This allows senders to ramp up their policy enforcement gradually and prevent having to commit to a rigorous policy before getting feedback on their existing policy.
sp= (Receiver Policy)	Optional with a default value of none . Other values include the same range of values as the p= argument. This is the policy to be applied to mail from all identified subdomains of the given DMARC RR.

unencrypted in the DNS TXT RR, they are easily discovered, leaving the poster subject to unsolicited bulk email. Thus, the poster of the DNS TXT RR needs to employ some kind of abuse countermeasures.

Similar to SPF and DKIM, the DMARC policy in the TXT RR is encoded in a series of `tag=value` pairs separated by semicolons. Table 19.7 describes the common tags.

Once the DMARC RR is posted, messages from the sender are typically processed as follows:

1. The domain owner constructs an SPF policy and publishes it in its DNS database. The domain owner also configures its system for DKIM signing. Finally, the domain owner publishes via the DNS a DMARC message-handling policy.
2. The author generates a message and hands the message to the domain owner's designated mail submission service.
3. The submission service passes relevant details to the DKIM signing module in order to generate a DKIM signature to be applied to the message.
4. The submission service relays the now-signed message to its designated transport service for routing to its intended recipient(s).

DMARC on the Receiver Side

A message generated on the sender side may pass through other relays but eventually arrives at a receiver's transport service. The typical processing order for DMARC on the receiving side is the following:

1. The receiver performs standard validation tests, such as checking against IP blocklists and domain reputation lists, as well as enforcing rate limits from a particular source.
2. The receiver extracts the RFC 5322 From address from the message. This must contain a single, valid address or else the mail is refused as an error.
3. The receiver queries for the DMARC DNS record based on the sending domain. If none exists, terminate DMARC processing.
4. The receiver performs DKIM signature checks. If more than one DKIM signature exists in the message, one must verify.
5. The receiver queries for the sending domain's SPF record and performs SPF validation checks.
6. The receiver conducts Identifier Alignment checks between the RFC 5321 From and the results of the SPF and DKIM records (if present).
7. The results of these steps are passed to the DMARC module along with the Author's domain. The DMARC module attempts to retrieve a policy from the DNS for that domain. If none is found, the DMARC module determines the organizational domain and repeats the attempt to retrieve a policy from the DNS.
8. If a policy is found, it is combined with the Author's domain and the SPF and DKIM results to produce a DMARC policy result (a "pass" or "fail") and can optionally cause one of two kinds of reports to be generated.
9. Recipient transport service either delivers the message to the recipient inbox or takes other local policy action based on the DMARC result.
10. When requested, Recipient transport service collects data from the message delivery session to be used in providing feedback.

Figure 19.10, based on one at DMARC.org, summarizes the sending and receiving functional flow.

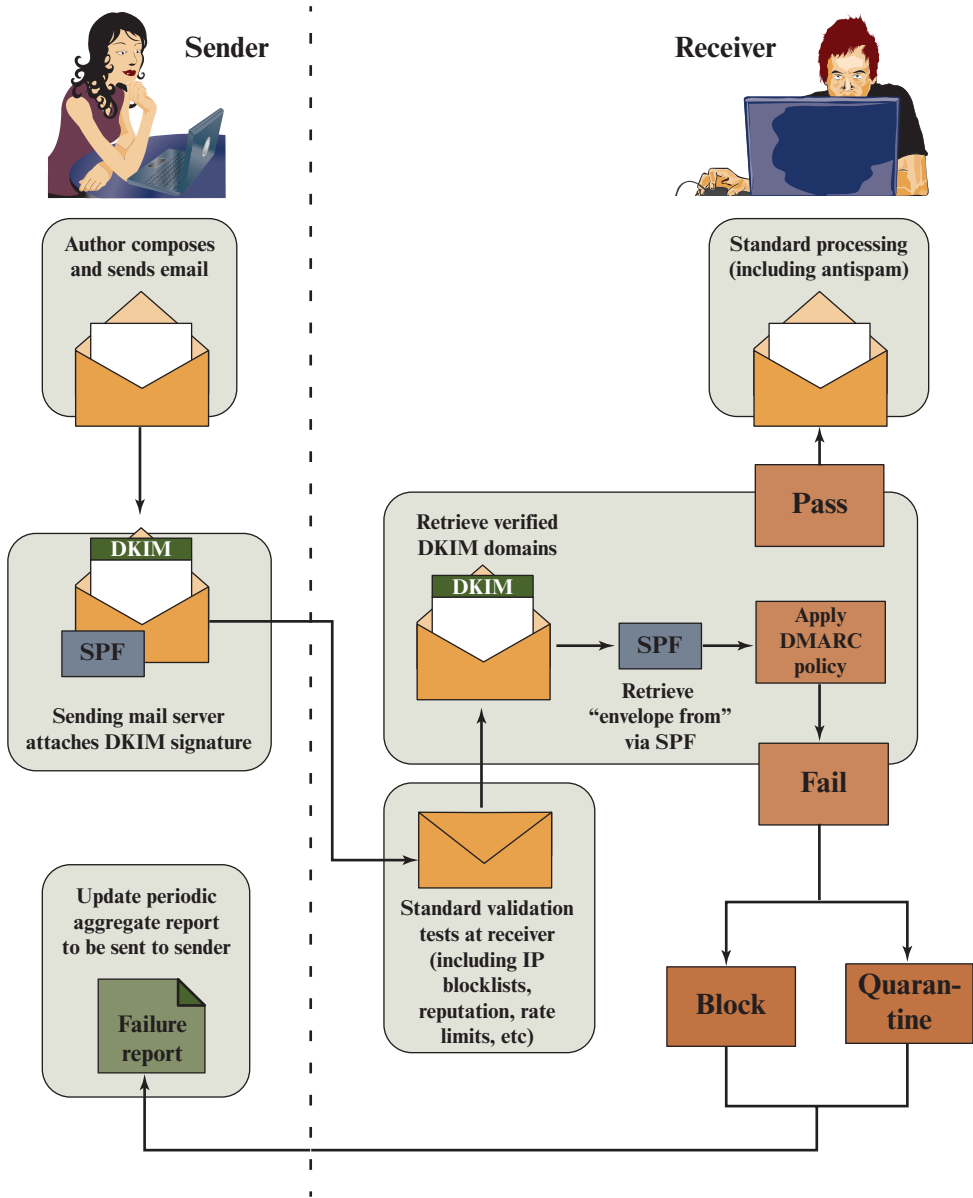

Figure 19.10 DMARC Functional Flow

DMARC Reports

DMARC reporting provides the sender's feedback on their SPF, DKIM, Identifier Alignment, and message disposition policies, which enable the sender to make these policies more effective. Two types of reports are sent: aggregate reports and forensic reports.

Aggregate reports are sent by receivers periodically and include aggregate figures for successful and unsuccessful message authentications, including:

- The sender's DMARC policy for that interval.
- The message disposition by the receiver (i.e., delivered, quarantined, rejected).
- SPF result for a given SPF identifier.
- DKIM result for a given DKIM identifier.
- Whether identifiers are in alignment or not.
- Results classified by sender subdomain.
- The sending and receiving domain pair.
- The policy applied, and whether this is different from the policy requested.
- The number of successful authentications.
- Totals for all messages received.

This information enables the sender to identify gaps in email infrastructure and policy. SP 800-177 recommends that a sending domain begin by setting a DMARC policy of **p=none**, so that the ultimate disposition of a message that fails some check is determined by the receiver's local policy. As DMARC aggregate reports are collected, the sender will have a quantitatively better assessment of the extent to which the sender's email is authenticated by outside receivers, and will be able to set a policy of **p=reject**, indicating that any message that fails the SPF, DKIM, and alignment checks really should be rejected. From their own traffic analysis, receivers can develop a determination of whether a sender's **p=reject** policy is sufficiently trustworthy to act on.

A forensic report helps the sender refine the component SPF and DKIM mechanisms as well as alerting the sender that their domain is being used as part of a phishing/spam campaign. Forensic reports are similar in format to aggregation reports, with these changes:

- Receivers include as much of the message and message header as is reasonable to allow the domain to investigate the failure. Add an Identity-Alignment field, with DKIM and SPF DMARC-method fields as appropriate.
- Optionally add a Delivery-Result field.
- Add DKIM Domain, DKIM Identity, and DKIM selector fields, if the message was DKIM signed. Optionally also add DKIM Canonical header and body fields.
- Add an additional DMARC authentication failure type, for use when some authentication mechanisms fail to produce aligned identifiers.

19.10 KEY TERMS, REVIEW QUESTIONS, AND PROBLEMS

Key Terms

base64 transfer encoding detached signature electronic mail	Post Office Protocol (POP3) session key	Simple Mail Transfer Protocol (SMTP) trust
---	---	--

Review Questions

- 19.1 What types of interoperability issues are involved in Internet mail architecture and how are they handled?
- 19.2 Briefly explain the protocol(s) that are recommended to enhance threat reduction.
- 19.3 What is the difference between a MIME content type and a MIME transfer encoding?
- 19.4 How does SPF work on the sender and receiver sides?
- 19.5 What are the strategies of the DomainKeys Identified Mail?
- 19.6 What is the role of STARTTLS in email security and how does it work?
- 19.7 What are the four principal services provided by S/MIME?
- 19.8 What is the utility of a detached signature?
- 19.9 What is DKIM?

Problems

- 19.1 The character sequence “<CR><LF>.<CR><LF>” indicates the end of mail data to a SMTP-server. What happens if the mail data itself contains that character sequence?
- 19.2 Using a comparison table, describe an example(s) of how SMTP, POP3, and IMAP correlate with and differ from each other.
- 19.3 If a lossless compression algorithm, such as ZIP, is used with S/MIME, why is it preferable to generate a signature before applying compression?
- 19.4 Before the deployment of the Domain Name System, a simple text file (HOSTS.TXT) centrally maintained at the SRI Network Information Center was used to enable mapping between host names and addresses. Each host connected to the Internet had to have an updated local copy of it to be able to use host names instead of having to cope directly with their IP addresses. Discuss the main advantages of the DNS over the old centralized HOSTS.TXT system.
- 19.5 Consider base64 conversion as a form of encryption. In this case, there is no key. But suppose that an opponent knew only that some form of substitution algorithm was being used to encrypt English text and did not guess that it was base64. How effective would this algorithm be against cryptanalysis?
- 19.6 Encode the text “ciphertext” using the following techniques. Assume characters are stored in 8-bit ASCII with zero parity.
 - a. base64
 - b. Quoted-printable
- 19.7 Describe the mechanisms of DANE and DMARC in email security using at least two different examples.

CHAPTER 20

IP SECURITY

20.1 IP Security Overview

- Applications of IPsec
- IPsec Documents
- IPsec Services

20.2 IP Security Policy

- Security Associations
- Security Association Database
- Security Policy Database
- IP Traffic Processing

20.3 Encapsulating Security Payload

- ESP Format
- Encryption and Authentication Algorithms
- Padding
- Anti-Replay Service
- Transport and Tunnel Modes

20.4 Combining Security Associations

- Authentication Plus Confidentiality
- Basic Combinations of Security Associations

20.5 Internet Key Exchange

- Key Determination Protocol
- Header and Payload Formats

20.6 Key Terms, Review Questions, and Problems

LEARNING OBJECTIVES

After studying this chapter, you should be able to:

- ◆ Present an overview of IP security (IPsec).
- ◆ Explain the difference between transport mode and tunnel mode.
- ◆ Understand the concept of security association.
- ◆ Explain the difference between the security association database and the security policy database.
- ◆ Summarize the traffic processing functions performed by IPsec for outbound packets and for inbound packets.
- ◆ Present an overview of Encapsulating Security Payload.
- ◆ Discuss the alternatives for combining security associations.
- ◆ Present an overview of Internet Key Exchange.
- ◆ Summarize the alternative cryptographic suites approved for use with IPsec.

There are application-specific security mechanisms for a number of application areas, including electronic mail (S/MIME, PGP), client/server (Kerberos), Web access (Secure Sockets Layer), and others. However, users have security concerns that cut across protocol layers. For example, an enterprise can run a secure, private IP network by disallowing links to untrusted sites, encrypting packets that leave the premises, and authenticating packets that enter the premises.¹ By implementing security at the IP level, an organization can ensure secure networking not only for applications that have security mechanisms but also for the many security-ignorant applications.

IP-level security encompasses three functional areas: authentication, confidentiality, and key management. The authentication mechanism assures that a received packet was, in fact, transmitted by the party identified as the source in the packet header. In addition, this mechanism assures that the packet has not been altered in transit. The confidentiality facility enables communicating nodes to encrypt messages to prevent eavesdropping by third parties. The key management facility is concerned with the secure exchange of keys.

We begin this chapter with an overview of **IP security (IPsec)** and an introduction to the IPsec architecture. We then look at each of the three functional areas in detail.

20.1 IP SECURITY OVERVIEW

In 1994, the Internet Architecture Board (IAB) issued a report titled “Security in the Internet Architecture” (RFC 1636). The report identified key areas for security mechanisms. Among these were the need to secure the network infrastructure from

¹In this chapter, the term *IP packet* refers to either an IPv4 datagram or an IPv6 packet.

unauthorized monitoring and control of network traffic and the need to secure end-user-to-end-user traffic using authentication and encryption mechanisms.

To provide security, the IAB included authentication and encryption as necessary security features in the next-generation IP, which has been issued as IPv6. Fortunately, these security capabilities were designed to be usable with both versions currently in use: **IPv4** and **IPv6**. This means that vendors can begin offering these features now, and many vendors now do have some IPsec capability in their products. The IPsec specification now exists as a set of Internet standards.

Applications of IPsec

IPsec provides the capability to secure communications across a LAN, across private and public WANs, and across the Internet. Examples of its use include:

- **Secure branch office connectivity over the Internet:** A company can build a secure virtual private network over the Internet or over a public WAN. This enables a business to rely heavily on the Internet and reduce its need for private networks, saving costs and network management overhead.
- **Secure remote access over the Internet:** An end user whose system is equipped with IP security protocols can make a local call to an Internet Service Provider (ISP) and gain secure access to a company network. This reduces the cost of toll charges for traveling employees and telecommuters.
- **Establishing extranet and intranet connectivity with partners:** IPsec can be used to secure communication with other organizations, ensuring authentication and confidentiality and providing a key exchange mechanism.
- **Enhancing electronic commerce security:** Even though some Web and electronic commerce applications have built-in security protocols, the use of IPsec enhances that security. IPsec guarantees that all traffic designated by the network administrator is both encrypted and authenticated, adding an additional layer of security to whatever is provided at the application layer.

The principal feature of IPsec that enables it to support these varied applications is that it can encrypt and/or authenticate *all* traffic at the IP level. Thus, all distributed applications (including remote logon, client/server, email, file transfer, Web access, and so on) can be secured.

IPsec Documents

IPsec encompasses three functional areas: authentication, confidentiality, and key management. The totality of the IPsec specification is scattered across dozens of RFCs and draft IETF documents, making this the most complex and difficult to grasp of all IETF specifications. The best way to grasp the scope of IPsec is to consult the latest version of the IPsec document roadmap, which as of this writing is RFC 6071 [*IP Security (IPsec) and Internet Key Exchange (IKE) Document Roadmap*, February 2011]. The documents can be categorized into the following groups.

- **Architecture:** Covers the general concepts, security requirements, definitions, and mechanisms defining IPsec technology. The current specification is RFC 4301, *Security Architecture for the Internet Protocol*.

- **Authentication Header (AH):** AH is an extension header to provide message authentication. The current specification is RFC 4302, *IP Authentication Header*. Because message authentication is provided by ESP, the use of AH is deprecated. It is included in IPsecv3 for backward compatibility but should not be used in new applications. We do not discuss AH in this chapter.
- **Encapsulating Security Payload (ESP):** ESP consists of an encapsulating header and trailer used to provide encryption or combined encryption/authentication. The current specification is RFC 4303, *IP Encapsulating Security Payload (ESP)*.
- **Internet Key Exchange (IKE):** This is a collection of documents describing the key management schemes for use with IPsec. The main specification is RFC 7296, *Internet Key Exchange (IKEv2) Protocol*, but there are a number of related RFCs.
- **Cryptographic algorithms:** This category encompasses a large set of documents that define and describe cryptographic algorithms for encryption, message authentication, pseudorandom functions (PRFs), and cryptographic key exchange.
- **Other:** There are a variety of other IPsec-related RFCs, including those dealing with security policy and management information base (MIB) content.

IPsec Services

IPsec provides security services at the IP layer by enabling a system to select required security protocols, determine the algorithm(s) to use for the service(s), and put in place any cryptographic keys required to provide the requested services. Two protocols are used to provide security: an authentication protocol designated by the header of the protocol, Authentication Header (AH); and a combined encryption/authentication protocol designated by the format of the packet for that protocol, Encapsulating Security Payload (ESP). RFC 4301 lists the following services:

- Access control
- Connectionless integrity
- Data origin authentication
- Rejection of replayed packets (a form of partial sequence integrity)
- Confidentiality (encryption)
- Limited traffic flow confidentiality

20.2 IP SECURITY POLICY

Fundamental to the operation of IPsec is the concept of a security policy applied to each IP packet that transits from a source to a destination. IPsec policy is determined primarily by the interaction of two databases, the **security association database (SAD)** and the **security policy database (SPD)**. This section provides an overview of these two databases and then summarizes their use during IPsec operation. Figure 20.1 illustrates the relevant relationships.

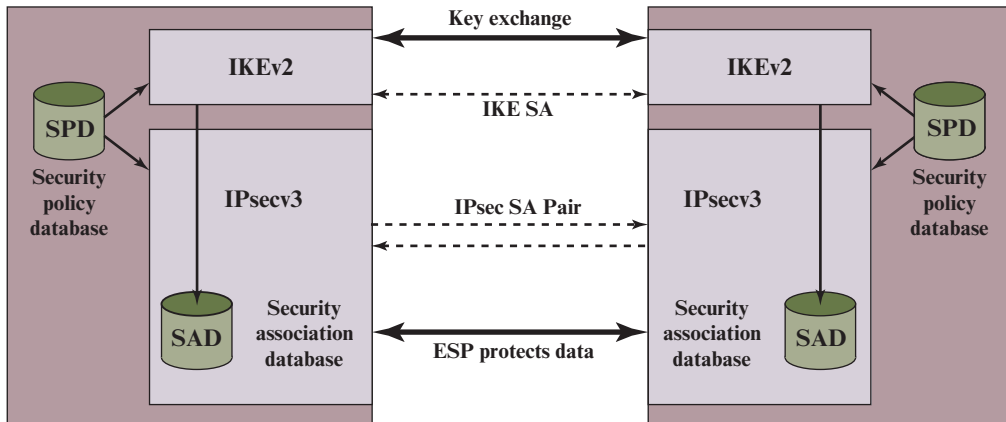

Figure 20.1 IPsec Architecture

Security Associations

A key concept that appears in both the authentication and confidentiality mechanisms for IP is the security association (SA). An association is a one-way logical connection between a sender and a receiver that affords security services to the traffic carried on it. If a peer relationship is needed for two-way secure exchange, then two security associations are required.

A security association is uniquely identified by three parameters.

- **Security Parameters Index (SPI):** A 32-bit unsigned integer assigned to this SA and having local significance only. The SPI is carried in AH and ESP headers to enable the receiving system to select the SA under which a received packet will be processed.
- **IP Destination Address:** This is the address of the destination endpoint of the SA, which may be an end-user system or a network system such as a firewall or router.
- **Security Protocol Identifier:** This field from the outer IP header indicates whether the association is an AH or ESP security association.

Hence, in any IP packet, the security association is uniquely identified by the Destination Address in the IPv4 or IPv6 header and the SPI in the enclosed extension header (AH or ESP).

Security Association Database

In each IPsec implementation, there is a nominal² Security Association Database that defines the parameters associated with each SA. A security association is normally defined by the following parameters in an SAD entry.

- **Security Parameter Index:** A 32-bit value selected by the receiving end of an SA to uniquely identify the SA. In an SAD entry for an outbound SA, the SPI is used to construct the packet's AH or ESP header. In an SAD entry for an inbound SA, the SPI is used to map traffic to the appropriate SA.

²Nominal in the sense that the functionality provided by a Security Association Database must be present in any IPsec implementation, but the way in which that functionality is provided is up to the implementer.

- **Sequence Number Counter:** A 32-bit value used to generate the Sequence Number field in AH or ESP headers, described in Section 20.3 (required for all implementations).
- **Sequence Counter Overflow:** A flag indicating whether overflow of the Sequence Number Counter should generate an auditable event and prevent further transmission of packets on this SA (required for all implementations).
- **Anti-Replay Window:** Used to determine whether an inbound AH or ESP packet is a replay, described in Section 20.3 (required for all implementations).
- **AH Information:** Authentication algorithm, keys, key lifetimes, and related parameters being used with AH (required for AH implementations).
- **ESP Information:** Encryption and authentication algorithm, keys, initialization values, key lifetimes, and related parameters being used with ESP (required for ESP implementations).
- **Lifetime of this Security Association:** A time interval or byte count after which an SA must be replaced with a new SA (and new SPI) or terminated, plus an indication of which of these actions should occur (required for all implementations).
- **IPsec Protocol Mode:** Tunnel, transport, or wildcard.
- **Path MTU:** Any observed path maximum transmission unit (maximum size of a packet that can be transmitted without fragmentation) and aging variables (required for all implementations).

The key management mechanism that is used to distribute keys is coupled to the authentication and privacy mechanisms only by way of the Security Parameters Index (SPI). Hence, authentication and privacy have been specified independent of any specific key management mechanism.

IPsec provides the user with considerable flexibility in the way in which IPsec services are applied to IP traffic. As we will see later, SAs can be combined in a number of ways to yield the desired user configuration. Furthermore, IPsec provides a high degree of granularity in discriminating between traffic that is afforded IPsec protection and traffic that is allowed to bypass IPsec, as in the former case relating IP traffic to specific SAs.

Security Policy Database

The means by which IP traffic is related to specific SAs (or no SA in the case of traffic allowed to bypass IPsec) is the nominal Security Policy Database (SPD). In its simplest form, an SPD contains entries, each of which defines a subset of IP traffic and points to an SA for that traffic. In more complex environments, there may be multiple entries that potentially relate to a single SA or multiple SAs associated with a single SPD entry. The reader is referred to the relevant IPsec documents for a full discussion.

Each SPD entry is defined by a set of IP and upper-layer protocol field values, called *selectors*. In effect, these selectors are used to filter outgoing traffic in order to map it into a particular SA. Outbound processing obeys the following general sequence for each IP packet.

1. Compare the values of the appropriate fields in the packet (the selector fields) against the SPD to find a matching SPD entry, which will point to zero or more SAs.

2. Determine the SA if any for this packet and its associated SPI.
3. Do the required IPsec processing (i.e., AH or ESP processing).

The following selectors determine an SPD entry:

- **Remote IP Address:** This may be a single IP address, an enumerated list or range of addresses, or a wildcard (mask) address. The latter two are required to support more than one destination system sharing the same SA (e.g., behind a firewall).
- **Local IP Address:** This may be a single IP address, an enumerated list or range of addresses, or a wildcard (mask) address. The latter two are required to support more than one source system sharing the same SA (e.g., behind a firewall).
- **Next Layer Protocol:** The IP protocol header (IPv4, IPv6, or IPv6 Extension) includes a field (Protocol for IPv4, Next Header for IPv6 or IPv6 Extension) that designates the protocol operating over IP. This is an individual protocol number, ANY, or for IPv6 only, OPAQUE. If AH or ESP is used, then this IP protocol header immediately precedes the AH or ESP header in the packet.
- **Name:** A user identifier from the operating system. This is not a field in the IP or upper-layer headers but is available if IPsec is running on the same operating system as the user.
- **Local and Remote Ports:** These may be individual TCP or UDP port values, an enumerated list of ports, or a wildcard port.

Table 20.1 provides an example of an SPD on a host system (as opposed to a network system such as a firewall or router). This table reflects the following configuration: A local network configuration consists of two networks. The basic corporate network configuration has the IP network number 1.2.3.0/24. The local configuration also includes a secure LAN, often known as a DMZ, that is identified as 1.2.4.0/24. The DMZ is protected from both the outside world and the rest of the corporate LAN by firewalls. The host in this example has the IP address 1.2.3.10, and it is authorized to connect to the server 1.2.4.10 in the DMZ.

The entries in the SPD should be self-explanatory. For example, UDP port 500 is the designated port for IKE. Any traffic from the local host to a remote host for purposes of an IKE exchange bypasses the IPsec processing.

Table 20.1 Host SPD Example

Protocol	Local IP	Port	Remote IP	Port	Action	Comment
UDP	1.2.3.101	500	*	500	BYPASS	IKE
ICMP	1.2.3.101	*	*	*	BYPASS	Error messages
*	1.2.3.101	*	1.2.3.0/24	*	PROTECT: ESP intransport-mode	Encrypt intranet traffic
TCP	1.2.3.101	*	1.2.4.10	80	PROTECT: ESP intransport-mode	Encrypt to server
TCP	1.2.3.101	*	1.2.4.10	443	BYPASS	TLS: avoid double encryption
*	1.2.3.101	*	1.2.4.0/24	*	DISCARD	Others in DMZ
*	1.2.3.101	*	*	*	BYPASS	Internet

IP Traffic Processing

IPsec is executed on a packet-by-packet basis. When IPsec is implemented, each outbound IP packet is processed by the IPsec logic before transmission, and each inbound packet is processed by the IPsec logic after reception and before passing the packet contents on to the next higher layer (e.g., TCP or UDP). We look at the logic of these two situations in turn.

OUTBOUND PACKETS Figure 20.2 highlights the main elements of IPsec processing for outbound traffic. A block of data from a higher layer, such as TCP, is passed down to the IP layer and an IP packet is formed, consisting of an IP header and an IP body. Then the following steps occur:

1. IPsec searches the SPD for a match to this packet.
2. If no match is found, then the packet is discarded and an error message is generated.
3. If a match is found, further processing is determined by the first matching entry in the SPD. If the policy for this packet is DISCARD, then the packet is discarded. If the policy is BYPASS, then there is no further IPsec processing; the packet is forwarded to the network for transmission.
4. If the policy is PROTECT, then a search is made of the SAD for a matching entry. If no entry is found, then IKE is invoked to create an SA with the appropriate keys and an entry is made in the SA.
5. The matching entry in the SAD determines the processing for this packet. Either encryption, authentication, or both can be performed, and either transport or tunnel mode can be used. The packet is then forwarded to the network for transmission.

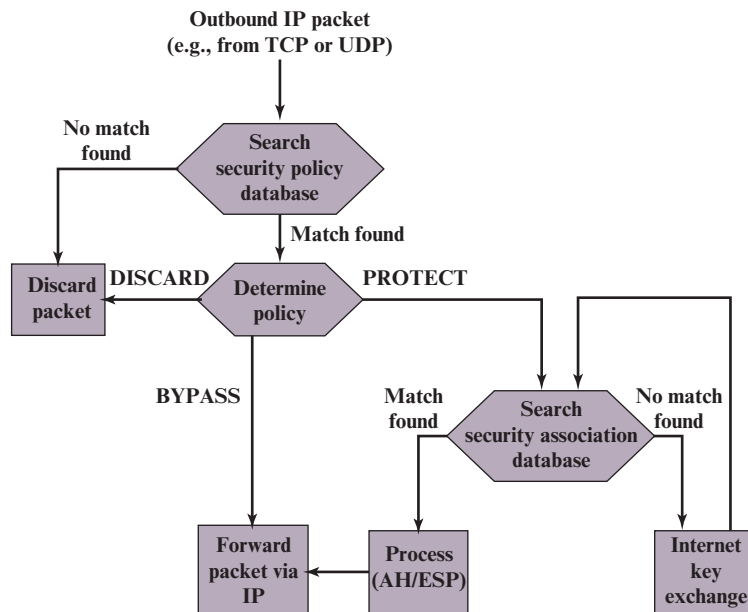

Figure 20.2 Processing Model for Outbound Packets

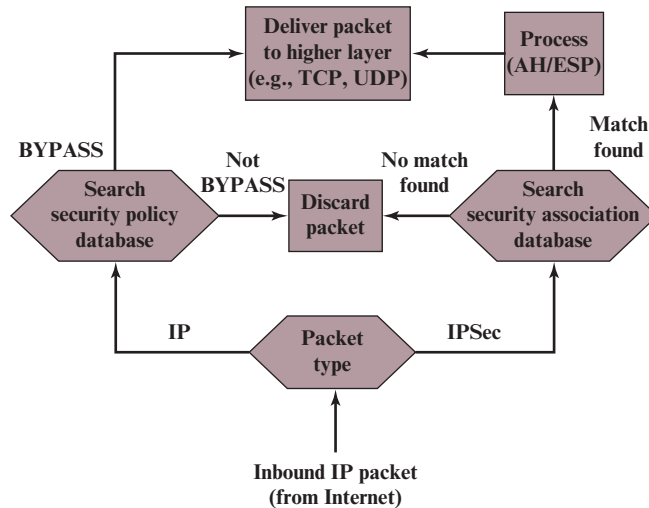

Figure 20.3 Processing Model for Inbound Packets

INBOUND PACKETS Figure 20.3 highlights the main elements of IPsec processing for inbound traffic. An incoming IP packet triggers the IPsec processing. The following steps occur:

1. IPsec determines whether this is an unsecured IP packet or one that has ESP or AH headers/trailers, by examining the IP Protocol field (IPv4) or Next Header field (IPv6).
2. If the packet is unsecured, IPsec searches the SPD for a match to this packet. If the first matching entry has a policy of BYPASS, the IP header is processed and stripped off and the packet body is delivered to the next higher layer, such as TCP. If the first matching entry has a policy of PROTECT or DISCARD, or if there is no matching entry, the packet is discarded.
3. For a secured packet, IPsec searches the SAD. If no match is found, the packet is discarded. Otherwise, IPsec applies the appropriate ESP or AH processing. Then, the IP header is processed and stripped off and the packet body is delivered to the next higher layer, such as TCP.

20.3 ENCAPSULATING SECURITY PAYLOAD

ESP can be used to provide confidentiality, data origin authentication, connectionless integrity, an anti-replay service (a form of partial sequence integrity), and (limited) traffic flow confidentiality. The set of services provided depends on options selected at the time of Security Association (SA) establishment and on the location of the implementation in a network topology.

ESP can work with a variety of encryption and authentication algorithms, including authenticated encryption algorithms such as GCM.

ESP Format

Figure 20.4a shows the top-level format of an ESP packet. It contains the following fields.

- **Security Parameters Index (32 bits):** Identifies a security association.
- **Sequence Number (32 bits):** A monotonically increasing counter value; this provides an anti-replay function, as discussed for AH.
- **Payload Data (variable):** This is a transport-level segment (transport mode) or IP packet (tunnel mode) that is protected by encryption.
- **Padding (0–255 bytes):** The purpose of this field is discussed later.
- **Pad Length (8 bits):** Indicates the number of pad bytes immediately preceding this field.
- **Next Header (8 bits):** Identifies the type of data contained in the payload data field by identifying the first header in that payload (e.g., an extension header in IPv6, or an upper-layer protocol such as TCP).
- **Integrity Check Value (variable):** A variable-length field (must be an integral number of 32-bit words) that contains the Integrity Check Value computed over the ESP packet minus the Authentication Data field.

When any combined mode algorithm is employed, the algorithm itself is expected to return both decrypted plaintext and a pass/fail indication for the integrity check. For combined mode algorithms, the ICV that would normally appear at the end of the ESP packet (when integrity is selected) may be omitted. When the ICV is omitted and integrity is selected, it is the responsibility of the combined mode algorithm to encode within the Payload Data an ICV-equivalent means of verifying the integrity of the packet.

Two additional fields may be present in the payload (Figure 20.4b). An **initialization value (IV)**, or nonce, is present if this is required by the encryption or authenticated encryption algorithm used for ESP. If tunnel mode is being used, then the IPsec implementation may add **traffic flow confidentiality (TFC)** padding after the Payload Data and before the Padding field, as explained subsequently.

Encryption and Authentication Algorithms

The Payload Data, Padding, Pad Length, and Next Header fields are encrypted by the ESP service. If the algorithm used to encrypt the payload requires cryptographic synchronization data, such as an initialization vector (IV), then these data may be carried explicitly at the beginning of the Payload Data field. If included, an IV is usually not encrypted, although it is often referred to as being part of the ciphertext.

The ICV field is optional. It is present only if the integrity service is selected and is provided by either a separate integrity algorithm or a combined mode algorithm that uses an ICV. The ICV is computed after the encryption is performed. This order of processing facilitates rapid detection and rejection of replayed or bogus packets by the receiver prior to decrypting the packet, hence potentially reducing the impact of denial of service (DoS) attacks. It also allows for the possibility of parallel processing of packets at the receiver that is decryption can take place in parallel with integrity checking. Note that because the ICV is not protected by encryption, a keyed integrity algorithm must be employed to compute the ICV.

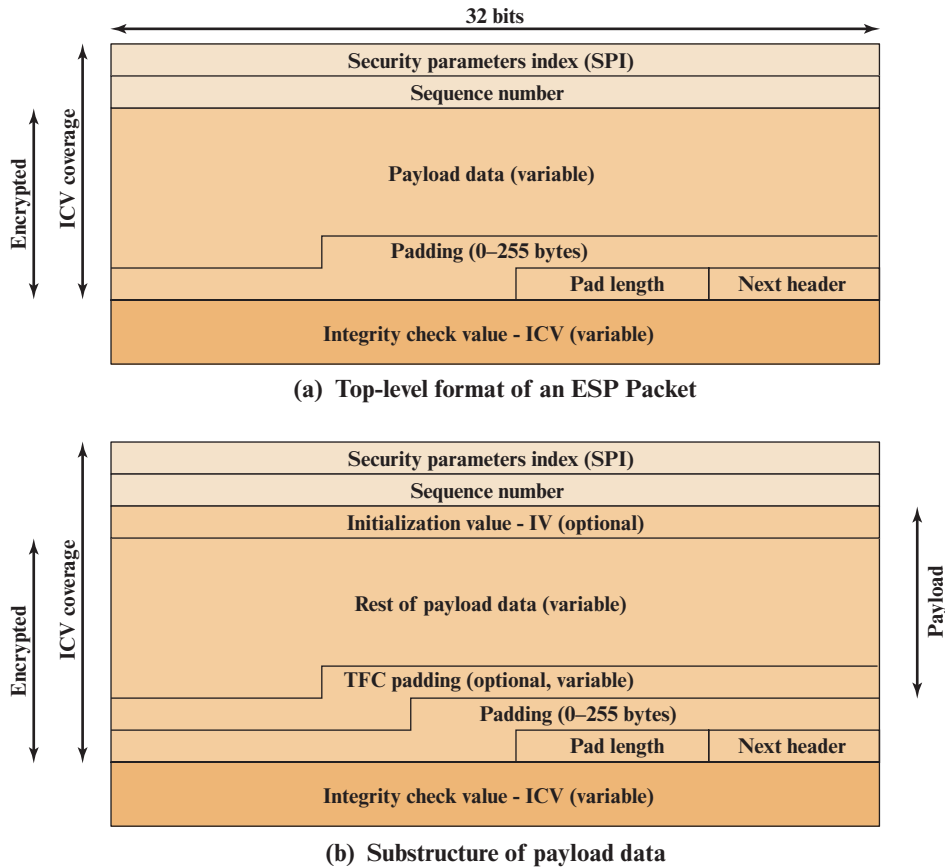

Figure 20.4 ESP Packet Format

Padding

The Padding field serves several purposes:

- If an encryption algorithm requires the plaintext to be a multiple of some number of bytes (e.g., the multiple of a single block for a block cipher), the Padding field is used to expand the plaintext (consisting of the Payload Data, Padding, Pad Length, and Next Header fields) to the required length.
- The ESP format requires that the Pad Length and Next Header fields be right aligned within a 32-bit word. Equivalently, the ciphertext must be an integer multiple of 32 bits. The Padding field is used to assure this alignment.
- Additional padding may be added to provide partial traffic-flow confidentiality by concealing the actual length of the payload.

Anti-Replay Service

A **replay attack** is one in which an attacker obtains a copy of an authenticated packet and later transmits it to the intended destination. The receipt of duplicate, authenticated IP packets may disrupt service in some way or may have some other undesired

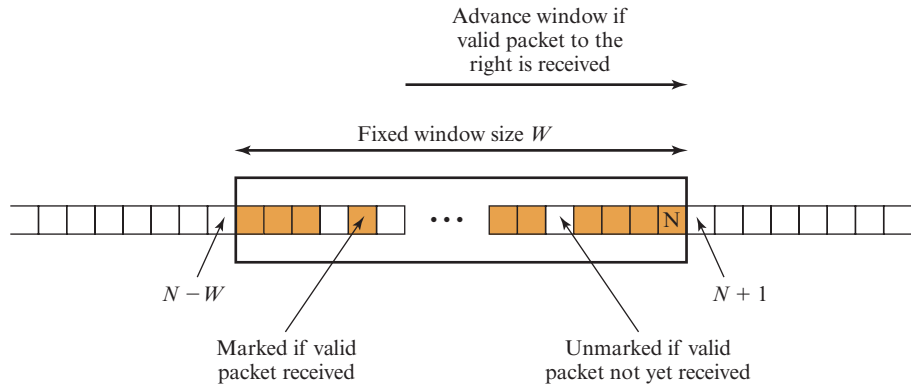

Figure 20.5 Anti-replay Mechanism

consequence. The Sequence Number field is designed to thwart such attacks. First, we discuss sequence number generation by the sender, and then we look at how it is processed by the recipient.

When a new SA is established, the **sender** initializes a sequence number counter to 0. Each time that a packet is sent on this SA, the sender increments the counter and places the value in the Sequence Number field. Thus, the first value to be used is 1. If anti-replay is enabled (the default), the sender must not allow the sequence number to cycle past $2^{32} - 1$ back to zero. Otherwise, there would be multiple valid packets with the same sequence number. If the limit of $2^{32} - 1$ is reached, the sender should terminate this SA and negotiate a new SA with a new key.

Because IP is a connectionless, unreliable service, the protocol does not guarantee that packets will be delivered in order and does not guarantee that all packets will be delivered. Therefore, the IPsec authentication document dictates that the **receiver** should implement a window of size W , with a default of $W = 64$. The right edge of the window represents the highest sequence number, N , so far received for a valid packet. For any packet with a sequence number in the range from $N - W + 1$ to N that has been correctly received (i.e., properly authenticated), the corresponding slot in the window is marked (Figure 20.5). Inbound processing proceeds as follows when a packet is received:

1. If the received packet falls within the window and is new, the MAC is checked. If the packet is authenticated, the corresponding slot in the window is marked.
2. If the received packet is to the right of the window and is new, the MAC is checked. If the packet is authenticated, the window is advanced so that this sequence number is the right edge of the window, and the corresponding slot in the window is marked.
3. If the received packet is to the left of the window or if authentication fails, the packet is discarded; this is an auditable event.

Transport and Tunnel Modes

Both AH and ESP support two modes of use: transport and tunnel mode. The operation of these two modes is best understood in the context of a description of ESP, which is more widely used than AH. In what follows, we look at the scope of ESP for

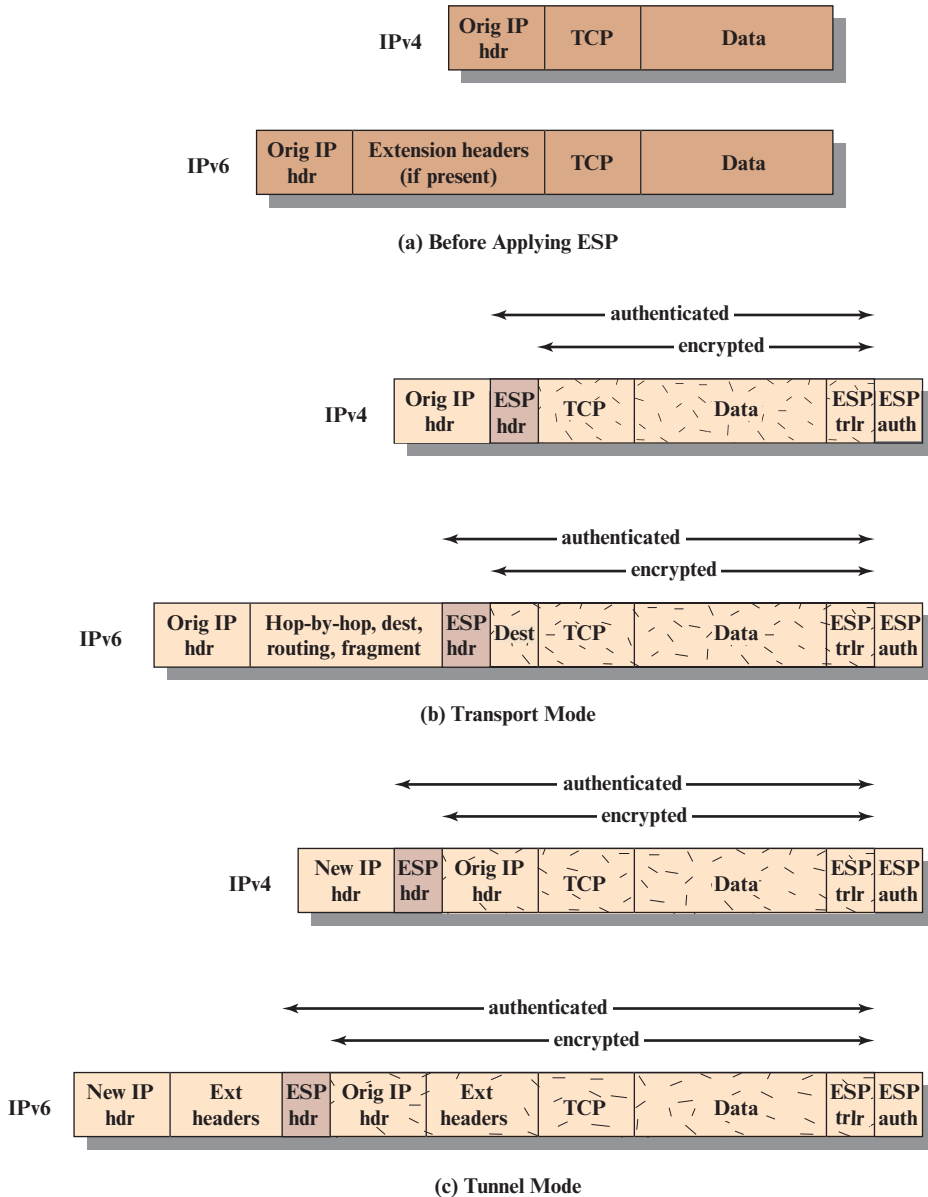

Figure 20.6 Scope of ESP Encryption and Authentication

the two modes. The former technique is supported by a transport mode SA, while the latter technique uses a tunnel mode SA.

The considerations are somewhat different for IPv4 and IPv6. We use the packet formats of Figure 20.6a as a starting point.

TRANSPORT MODE ESP **Transport mode** provides protection primarily for upper-layer protocols. That is, transport mode protection extends to the payload of an IP packet.

Examples include a TCP or UDP segment or an ICMP packet, all of which operate directly above IP in a host protocol stack. Typically, transport mode is used for end-to-end communication between two hosts (e.g., a client and a server, or two workstations; see Figure 20.7). When a host runs AH or ESP over IPv4, the payload is the data that normally follow the IP header. For IPv6, the payload is the data that normally follow both the IP header and any IPv6 extensions headers that are present, with the possible exception of the destination options header, which may be included in the protection. Transport mode ESP is used to encrypt and optionally authenticate the data carried by IP (e.g., a TCP segment), as shown in Figure 20.6b. For this mode using IPv4, the ESP header is inserted into the IP packet immediately prior to the transport-layer header (e.g., TCP, UDP, ICMP), and an ESP trailer (Padding, Pad Length, and Next Header fields) is placed after the IP packet. If authentication is selected, the ESP Authentication Data field is added after the ESP trailer. The entire transport-level segment plus the ESP trailer are encrypted. Authentication covers all of the ciphertext plus the ESP header.

In the context of IPv6, ESP is viewed as an end-to-end payload; that is, it is not examined or processed by intermediate routers. Therefore, the ESP header appears after the IPv6 base header and the hop-by-hop, routing, and fragment extension headers. The destination options extension header could appear before or after the ESP header, depending on the semantics desired. For IPv6, encryption covers the entire transport-level segment plus the ESP trailer plus the destination options extension header if it occurs after the ESP header. Again, authentication covers the ciphertext plus the ESP header.

Transport mode operation may be summarized as follows.

1. At the source, the block of data consisting of the ESP trailer plus the entire transport-layer segment is encrypted and the plaintext of this block is replaced with its ciphertext to form the IP packet for transmission. Authentication is added if this option is selected.
2. The packet is then routed to the destination. Each intermediate router needs to examine and process the IP header plus any plaintext IP extension headers but does not need to examine the ciphertext.
3. The destination node examines and processes the IP header plus any plaintext IP extension headers. Then, on the basis of the SPI in the ESP header, the destination node decrypts the remainder of the packet to recover the plaintext transport-layer segment.

Transport mode operation provides confidentiality for any application that uses it, thus avoiding the need to implement confidentiality in every individual application. One drawback to this mode is that it is possible to do traffic analysis on the transmitted packets.

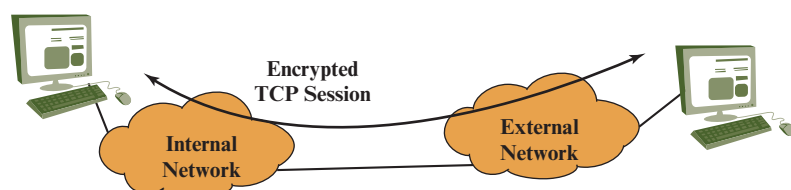

Figure 20.7 End-to-end IPsec Transport-Mode Encryption

TUNNEL MODE ESP Tunnel mode provides protection to the entire IP packet (Figure 20.6c). To achieve this, after the AH or ESP fields are added to the IP packet, the entire packet plus security fields is treated as the payload of new outer IP packet with a new outer IP header. The entire original, inner, packet travels through a tunnel from one point of an IP network to another; no routers along the way are able to examine the inner IP header. Because the original packet is encapsulated, the new, larger packet may have totally different source and destination addresses, adding to the security. Tunnel mode is used when one or both ends of a security association (SA) are a security gateway, such as a firewall or router that implements IPsec. With tunnel mode, a number of hosts on networks behind firewalls may engage in secure communications without implementing IPsec. The unprotected packets generated by such hosts are tunneled through external networks by tunnel mode SAs set up by the IPsec software in the firewall or secure router at the boundary of the local network.

Here is an example of how tunnel mode IPsec operates. Host A on a network generates an IP packet with the destination address of host B on another network. This packet is routed from the originating host to a firewall or secure router at the boundary of A's network. The firewall filters all outgoing packets to determine the need for IPsec processing. If this packet from A to B requires IPsec, the firewall performs IPsec processing and encapsulates the packet with an outer IP header. The source IP address of this outer IP packet is this firewall, and the destination address may be a firewall that forms the boundary to B's local network. This packet is now routed to B's firewall, with intermediate routers examining only the outer IP header. At B's firewall, the outer IP header is stripped off, and the inner packet is delivered to B.

Whereas the transport mode is suitable for protecting connections between hosts that support the ESP feature, the tunnel mode is useful in a configuration that includes a firewall or other sort of security gateway that protects a trusted network from external networks. In this latter case, encryption occurs only between an external host and the security gateway or between two security gateways. This relieves hosts on the internal network of the processing burden of encryption and simplifies the key distribution task by reducing the number of needed keys. Further, it thwarts traffic analysis based on ultimate destination.

Tunnel mode can be used to implement a secure virtual private network. A **virtual private network (VPN)** is a private network that is configured within a public network (a carrier's network or the Internet) in order to take advantage of the economies of scale and management facilities of large networks. VPNs are widely used by enterprises to create wide area networks that span large geographic areas, to provide site-to-site connections to branch offices, and to allow mobile users to dial up their company LANs. From the point of view of the provider, the public network facility is shared by many customers, with the traffic of each customer segregated from other traffic. Traffic designated as VPN traffic can only go from a VPN source to a destination in the same VPN. It is often the case that encryption and authentication facilities are provided for the VPN.

Figure 20.8 shows a typical scenario of IPsec tunnel mode for implementing a VPN. An organization maintains LANs at dispersed locations. Nonsecure IP traffic is conducted on each LAN. For traffic offsite, through some sort of private or public network, IPsec protocols are used. These protocols operate in networking devices, such as a router or firewall, that connect each LAN to the outside world. The IPsec networking device will typically encrypt and compress all traffic going

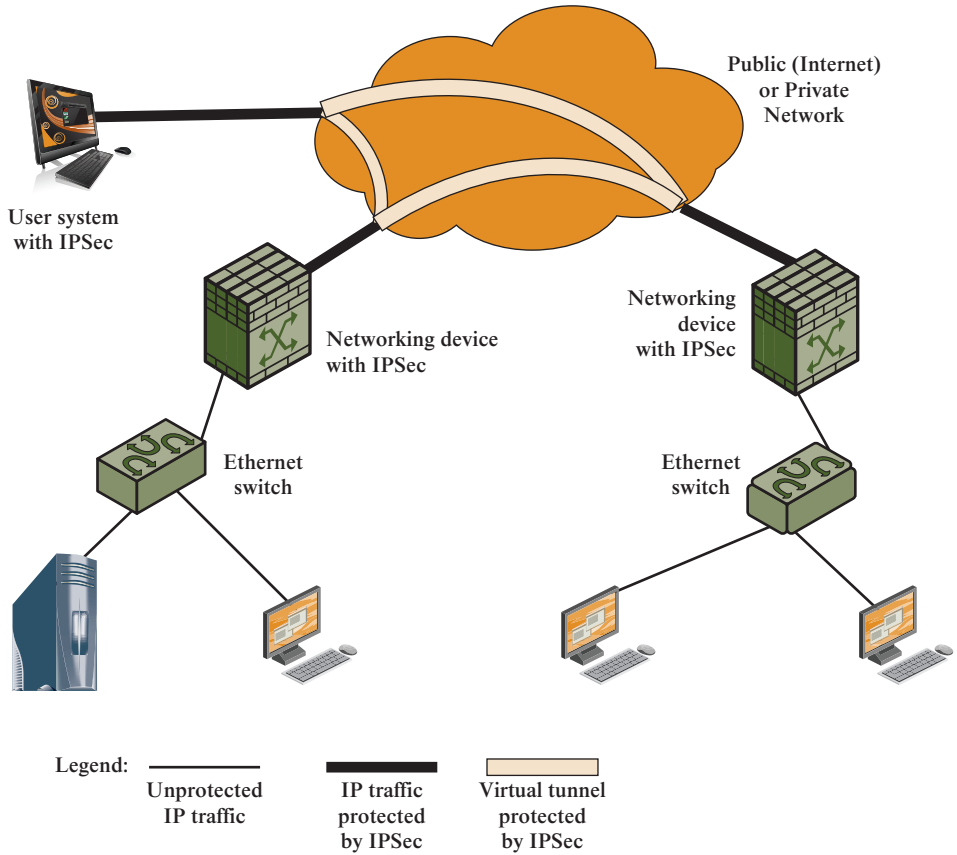
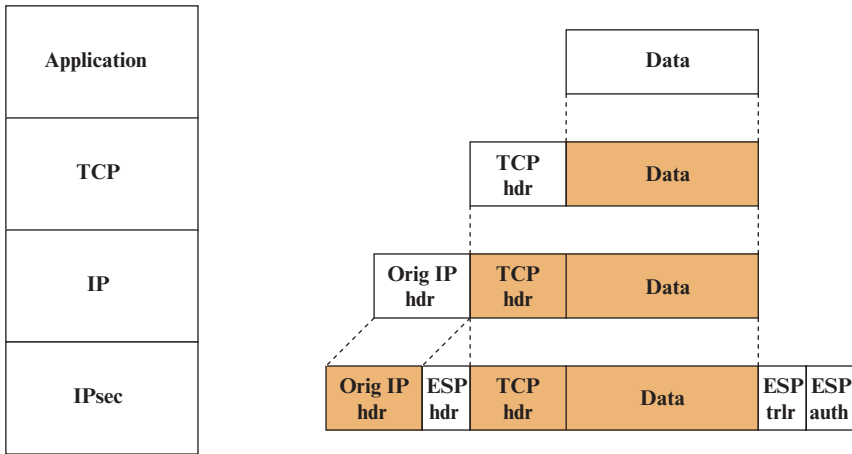

Figure 20.8 Example of Virtual Private Network Implemented with IPsec Tunnel Mode

into the Internet or other network and decrypt and decompress traffic coming from the network; these operations are transparent to workstations and servers on the LAN. Secure transmission is also possible with individual users who connect to the Internet or other network. Such user workstations must implement the IPsec protocols to provide security.

Table 20.2 Tunnel Mode and Transport Mode Functionality

	Transport Mode SA	Tunnel Mode SA
AH	Authenticates IP payload and selected portions of IP header and IPv6 extension headers.	Authenticates entire inner IP packet (inner header plus IP payload) plus selected portions of outer IP header and outer IPv6 extension headers.
ESP	Encrypts IP payload and any IPv6 extension headers following the ESP header.	Encrypts entire inner IP packet.
ESP with Authentication	Encrypts IP payload and any IPv6 extension headers following the ESP header. Authenticates IP payload but not IP header.	Encrypts entire inner IP packet. Authenticates inner IP packet.



(a) Transport mode

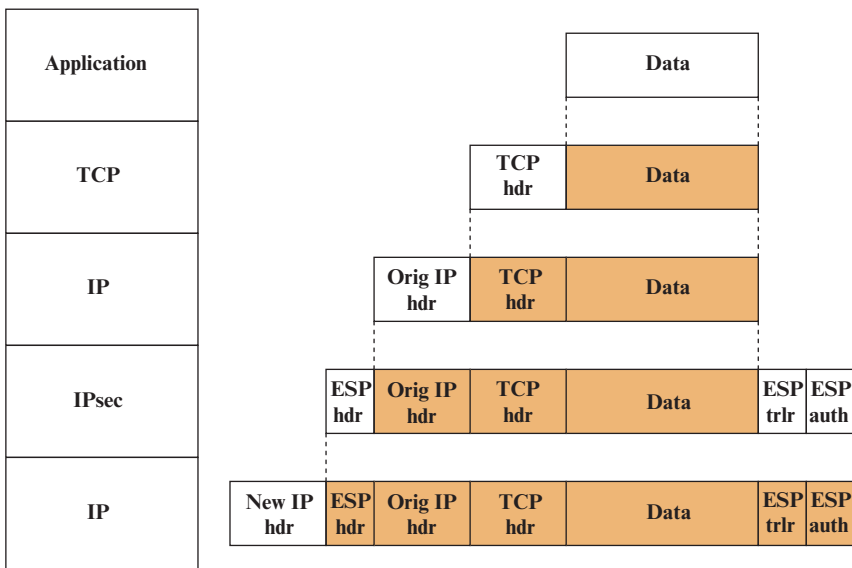

(b) Tunnel mode

Figure 20.9 Protocol Operation for ESP

Table 20.2 summarizes transport and tunnel mode functionality. Figure 20.9 shows the protocol architecture for the transport and tunnel modes.

20.4 COMBINING SECURITY ASSOCIATIONS

An individual SA can implement either the AH or ESP protocol but not both. Sometimes a particular traffic flow will call for the services provided by both AH and ESP. Further, a particular traffic flow may require IPsec services between hosts and,

for that same flow, separate services between security gateways, such as firewalls. In all of these cases, multiple SAs must be employed for the same traffic flow to achieve the desired IPsec services. The term *security association bundle* refers to a sequence of SAs through which traffic must be processed to provide a desired set of IPsec services. The SAs in a bundle may terminate at different endpoints or at the same endpoints.

Security associations may be combined into bundles in two ways:

- **Transport adjacency:** Refers to applying more than one security protocol to the same IP packet without invoking tunneling. This approach to combining AH and ESP allows for only one level of combination; further nesting yields no added benefit since the processing is performed at one IPsec instance: the (ultimate) destination.
- **Iterated tunneling:** Refers to the application of multiple layers of security protocols effected through IP tunneling. This approach allows for multiple levels of nesting, since each tunnel can originate or terminate at a different IPsec site along the path.

The two approaches can be combined, for example, by having a transport SA between hosts travel part of the way through a tunnel SA between security gateways.

One interesting issue that arises when considering SA bundles is the order in which authentication and encryption may be applied between a given pair of endpoints and the ways of doing so. We examine that issue next. Then we look at combinations of SAs that involve at least one tunnel.

Authentication Plus Confidentiality

Encryption and authentication can be combined in order to transmit an IP packet that has both confidentiality and authentication between hosts. We look at several approaches.

ESP WITH AUTHENTICATION OPTION This approach is illustrated in Figure 20.6. In this approach, the user first applies ESP to the data to be protected and then appends the authentication data field. There are actually two subcases:

- **Transport mode ESP:** Authentication and encryption apply to the IP payload delivered to the host, but the IP header is not protected.
- **Tunnel mode ESP:** Authentication applies to the entire IP packet delivered to the outer IP destination address (e.g., a firewall), and authentication is performed at that destination. The entire inner IP packet is protected by the privacy mechanism for delivery to the inner IP destination.

For both cases, authentication applies to the ciphertext rather than the plaintext.

TRANSPORT ADJACENCY Another way to apply authentication after encryption is to use two bundled transport SAs, with the inner being an ESP SA and the outer being an AH SA. In this case, ESP is used without its authentication option. Because the inner SA is a transport SA, encryption is applied to the IP payload. The resulting packet consists of an IP header (and possibly IPv6 header extensions) followed by an ESP. AH is then applied in transport mode, so that authentication covers the ESP plus the original IP header (and extensions) except for mutable fields. The advantage

of this approach over simply using a single ESP SA with the ESP authentication option is that the authentication covers more fields, including the source and destination IP addresses. The disadvantage is the overhead of two SAs versus one SA.

TRANSPORT-TUNNEL BUNDLE The use of authentication prior to encryption might be preferable for several reasons. First, because the authentication data are protected by encryption, it is impossible for anyone to intercept the message and alter the authentication data without detection. Second, it may be desirable to store the authentication information with the message at the destination for later reference. It is more convenient to do this if the authentication information applies to the unencrypted message; otherwise the message would have to be reencrypted to verify the authentication information.

One approach to applying authentication before encryption between two hosts is to use a bundle consisting of an inner AH transport SA and an outer ESP tunnel SA. In this case, authentication is applied to the IP payload plus the IP header (and extensions) except for mutable fields. The resulting IP packet is then processed in tunnel mode by ESP; the result is that the entire, authenticated inner packet is encrypted and a new outer IP header (and extensions) is added.

Basic Combinations of Security Associations

The IPsec Architecture document lists four examples of combinations of SAs that must be supported by compliant IPsec hosts (e.g., workstation, server) or security gateways (e.g., firewall, router). These are illustrated in Figure 20.10. The lower part of each case in the figure represents the physical connectivity of the elements; the upper part represents logical connectivity via one or more nested SAs. Each SA can be either AH or ESP. For host-to-host SAs, the mode may be either transport or tunnel; otherwise it must be tunnel mode.

Case 1. All security is provided between end systems that implement IPsec. For any two end systems to communicate via an SA, they must share the appropriate secret keys. Among the possible combinations are

- a. AH in transport mode
- b. ESP in transport mode
- c. ESP followed by AH in transport mode (an ESP SA inside an AH SA)
- d. Any one of a, b, or c inside an AH or ESP in tunnel mode

We have already discussed how these various combinations can be used to support authentication, encryption, authentication before encryption, and authentication after encryption.

Case 2. Security is provided only between gateways (routers, firewalls, etc.) and no hosts implement IPsec. This case illustrates simple virtual private network support. The security architecture document specifies that only a single tunnel SA is needed for this case. The tunnel could support AH, ESP, or ESP with the authentication option. Nested tunnels are not required, because the IPsec services apply to the entire inner packet.

Case 3. This builds on case 2 by adding end-to-end security. The same combinations discussed for cases 1 and 2 are allowed here. The gateway-to-gateway tunnel provides either authentication, confidentiality, or both for all traffic between

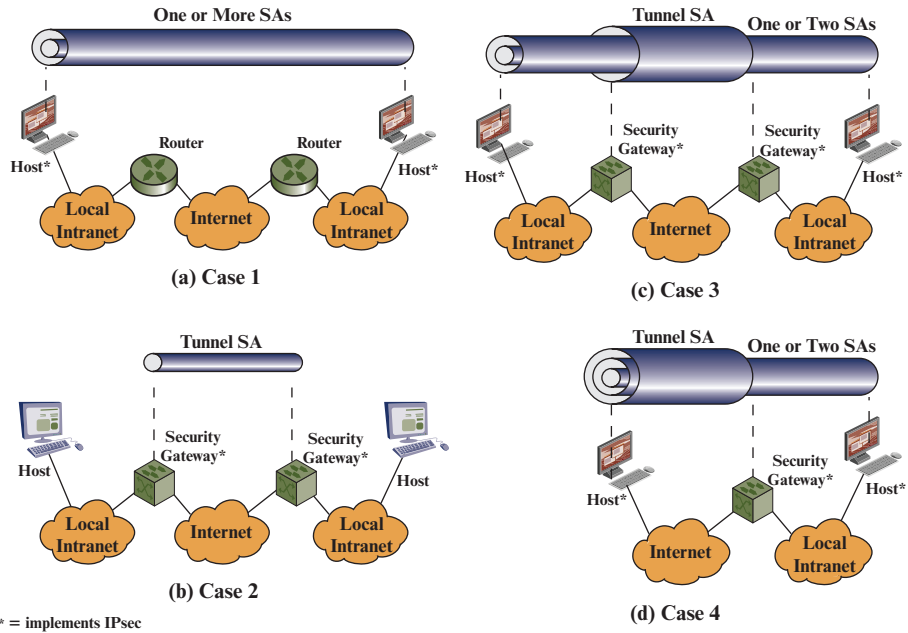

Figure 20.10 Basic Combinations of Security Associations

end systems. When the gateway-to-gateway tunnel is ESP, it also provides a limited form of traffic confidentiality. Individual hosts can implement any additional IPsec services required for given applications or given users by means of end-to-end SAs.

Case 4. This provides support for a remote host that uses the Internet to reach an organization's firewall and then to gain access to some server or workstation behind the firewall. Only tunnel mode is required between the remote host and the firewall. As in case 1, one or two SAs may be used between the remote host and the local host.

20.5 INTERNET KEY EXCHANGE

The key management portion of IPsec involves the determination and distribution of secret keys. A typical requirement is four keys for communication between two applications: transmit and receive pairs for both integrity and confidentiality. The IPsec Architecture document mandates support for two types of key management:

- **Manual:** A system administrator manually configures each system with its own keys and with the keys of other communicating systems. This is practical for small, relatively static environments.
- **Automated:** An automated system enables the on-demand creation of keys for SAs and facilitates the use of keys in a large distributed system with an evolving configuration.

The default automated key management protocol for IPsec is referred to as ISAKMP/Oakley and consists of the following elements:

- **Oakley Key Determination Protocol:** Oakley is a key exchange protocol based on the Diffie–Hellman algorithm but providing added security. Oakley is generic in that it does not dictate specific formats.
- **Internet Security Association and Key Management Protocol (ISAKMP):** ISAKMP provides a framework for Internet key management and provides the specific protocol support, including formats, for negotiation of security attributes.

ISAKMP by itself does not dictate a specific key exchange algorithm; rather, ISAKMP consists of a set of message types that enable the use of a variety of key exchange algorithms. Oakley is the specific key exchange algorithm mandated for use with the initial version of ISAKMP.

In IKEv2, the terms Oakley and ISAKMP are no longer used, and there are significant differences from the use of Oakley and ISAKMP in IKEv1. Nevertheless, the basic functionality is the same. In this section, we describe the IKEv2 specification.

Key Determination Protocol

IKE key determination is a refinement of the Diffie–Hellman key exchange algorithm. Recall that Diffie–Hellman involves the following interaction between users A and B. There is prior agreement on two global parameters: q , a large prime number; and α , a primitive root of q . A selects a random integer X_A as its private key and transmits to B its public key $Y_A = \alpha^{X_A} \bmod q$. Similarly, B selects a random integer X_B as its private key and transmits to A its public key $Y_B = \alpha^{X_B} \bmod q$. Each side can now compute the secret session key:

$$K = (Y_B)^{X_A} \bmod q = (Y_A)^{X_B} \bmod q = \alpha^{X_A X_B} \bmod q$$

The Diffie–Hellman algorithm has two attractive features:

- Secret keys are created only when needed. There is no need to store secret keys for a long period of time, exposing them to increased vulnerability.
- The exchange requires no pre-existing infrastructure other than an agreement on the global parameters.

However, there are a number of weaknesses to Diffie–Hellman, as pointed out in [HUIT98].

- It does not provide any information about the identities of the parties.
- It is subject to a man-in-the-middle attack, in which a third party C impersonates B while communicating with A and impersonates A while communicating with B. Both A and B end up negotiating a key with C, which can then listen to and pass on traffic. The man-in-the-middle attack proceeds as
 1. B sends his public key Y_B in a message addressed to A (see Figure 10.1).
 2. The enemy (E) intercepts this message. E saves B's public key and sends a message to A that has B's User ID but E's public key Y_E . This message is sent in such a way that it appears as though it was sent from B's host system.

A receives E's message and stores E's public key with B's User ID. Similarly, E sends a message to B with E's public key, purporting to come from A.

3. B computes a secret key K_1 based on B's private key and Y_E . A computes a secret key K_2 based on A's private key and Y_E . E computes K_1 using E's secret key X_E and Y_B and computes K_2 using X_E and Y_A .
 4. From now on, E is able to relay messages from A to B and from B to A, appropriately changing their encipherment en route in such a way that neither A nor B will know that they share their communication with E.
- It is computationally intensive. As a result, it is vulnerable to a clogging attack, in which an opponent requests a high number of keys. The victim spends considerable computing resources doing useless modular exponentiation rather than real work.

IKE key determination is designed to retain the advantages of Diffie–Hellman, while countering its weaknesses.

FEATURES OF IKE KEY DETERMINATION The IKE key determination algorithm is characterized by five important features:

1. It employs a mechanism known as cookies to thwart clogging attacks.
2. It enables the two parties to negotiate a *group*; this, in essence, specifies the global parameters of the Diffie–Hellman key exchange.
3. It uses nonces to ensure against replay attacks.
4. It enables the exchange of Diffie–Hellman public key values.
5. It authenticates the Diffie–Hellman exchange to thwart man-in-the-middle attacks.

We have already discussed Diffie–Hellman. Let us look at the remainder of these elements in turn. First, consider the problem of clogging attacks. In this attack, an opponent forges the source address of a legitimate user and sends a public Diffie–Hellman key to the victim. The victim then performs a modular exponentiation to compute the secret key. Repeated messages of this type can *clog* the victim's system with useless work. The **cookie exchange** requires that each side send a pseudorandom number, the cookie, in the initial message, which the other side acknowledges. This acknowledgment must be repeated in the first message of the Diffie–Hellman key exchange. If the source address was forged, the opponent gets no answer. Thus, an opponent can only force a user to generate acknowledgments and not to perform the Diffie–Hellman calculation.

IKE mandates that cookie generation satisfy three basic requirements:

1. The cookie must depend on the specific parties. This prevents an attacker from obtaining a cookie using a real IP address and UDP port and then using it to swamp the victim with requests from randomly chosen IP addresses or ports.
2. It must not be possible for anyone other than the issuing entity to generate cookies that will be accepted by that entity. This implies that the issuing entity will use local secret information in the generation and subsequent verification of a cookie. It must not be possible to deduce this secret information from any particular cookie. The point of this requirement is that the issuing entity need

not save copies of its cookies, which are then more vulnerable to discovery, but can verify an incoming cookie acknowledgment when it needs to.

3. The cookie generation and verification methods must be fast to thwart attacks intended to sabotage processor resources.

The recommended method for creating the cookie is to perform a fast hash (e.g., MD5) over the IP Source and Destination addresses, the UDP Source and Destination ports, and a locally generated secret value.

IKE key determination supports the use of different groups for the Diffie–Hellman key exchange. Each group includes the definition of the two global parameters and the identity of the algorithm. The current specification includes the following groups.

- Modular exponentiation with a 768-bit modulus

$$q = 2^{768} - 2^{704} - 1 + 2^{64} \times (\lfloor 2^{638} \times \pi \rfloor + 149686)$$

$$\alpha = 2$$

- Modular exponentiation with a 1024-bit modulus

$$q = 2^{1024} - 2^{960} - 1 + 2^{64} \times (\lfloor 2^{894} \times \pi \rfloor + 129093)$$

$$\alpha = 2$$

- Modular exponentiation with a 1536-bit modulus

- Parameters to be determined

- Elliptic curve group over 2^{155}

- Generator (hexadecimal): X = 7B, Y = 1C8

- Elliptic curve parameters (hexadecimal): A = 0, Y = 7338F

- Elliptic curve group over 2^{185}

- Generator (hexadecimal): X = 18, Y = D

- Elliptic curve parameters (hexadecimal): A = 0, Y = 1EE9

The first three groups are the classic Diffie–Hellman algorithm using modular exponentiation. The last two groups use the elliptic curve analog to Diffie–Hellman, which was described in Chapter 10.

IKE key determination employs **nonces** to ensure against replay attacks. Each nonce is a locally generated pseudorandom number. Nonces appear in responses and are encrypted during certain portions of the exchange to secure their use.

Three different **authentication** methods can be used with IKE key determination:

- **Digital signatures:** The exchange is authenticated by signing a mutually obtainable hash; each party encrypts the hash with its private key. The hash is generated over important parameters, such as user IDs and nonces.
- **Public-key encryption:** The exchange is authenticated by encrypting parameters such as IDs and nonces with the sender’s private key.
- **Symmetric-key encryption:** A key derived by some out-of-band mechanism can be used to authenticate the exchange by symmetric encryption of exchange parameters.

IKEv2 EXCHANGES The IKEv2 protocol involves the exchange of messages in pairs. The first two pairs of exchanges are referred to as the **initial exchanges** (Figure 20.11a). In the first exchange, the two peers exchange information concerning cryptographic algorithms and other security parameters they are willing to use along with nonces and Diffie–Hellman (DH) values. The result of this exchange is to set up a special SA called the IKE SA (see Figure 20.1). This SA defines parameters for a secure channel between the peers over which subsequent message exchanges take place. Thus, all subsequent IKE message exchanges are protected by encryption and message authentication. In the second exchange, the two parties authenticate one another and set up a first IPsec SA to be placed in the SADB and used for protecting ordinary (i.e. non-IKE) communications between the peers. Thus, four messages are needed to establish the first SA for general use.

The **CREATE_CHILD_SA exchange** can be used to establish further SAs for protecting traffic. The **informational exchange** is used to exchange management information, IKEv2 error messages, and other notifications.

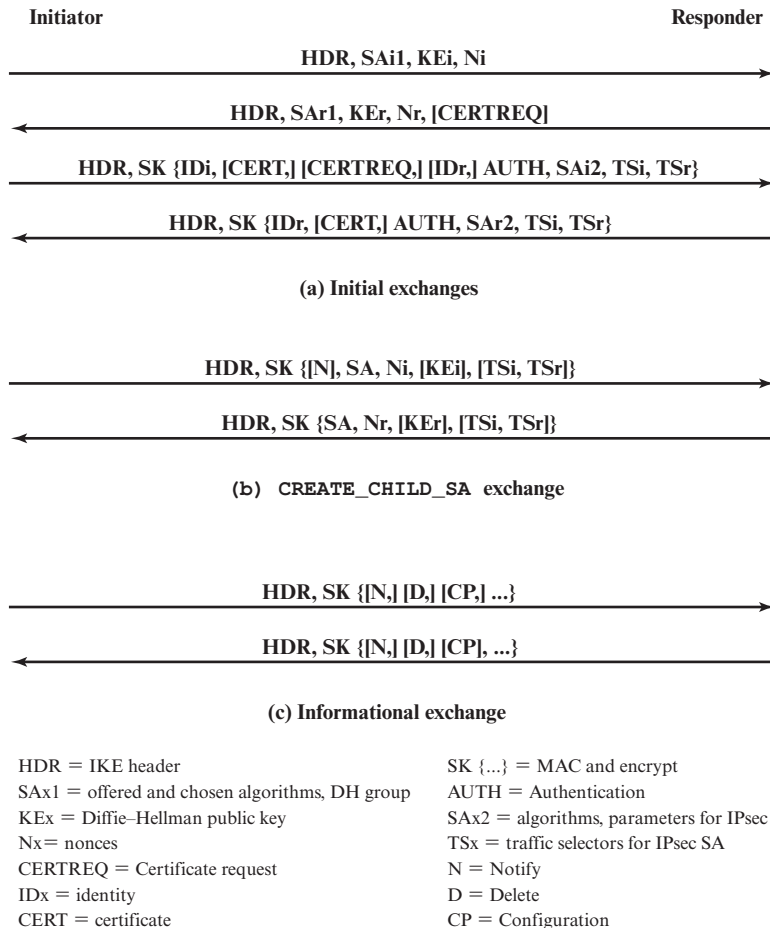

Figure 20.11 IKEv2 Exchanges

Header and Payload Formats

IKE defines procedures and packet formats to establish, negotiate, modify, and delete security associations. As part of SA establishment, IKE defines payloads for exchanging key generation and authentication data. These payload formats provide a consistent framework independent of the specific key exchange protocol, encryption algorithm, and authentication mechanism.

IKE HEADER FORMAT An IKE message consists of an IKE header followed by one or more payloads. All of this is carried in a transport protocol. The specification dictates that implementations must support the use of UDP for the transport protocol.

Figure 20.12a shows the header format for an IKE message. It consists of the following fields.

- **Initiator SPI (64 bits):** A value chosen by the initiator to identify a unique IKE security association (SA).
- **Responder SPI (64 bits):** A value chosen by the responder to identify a unique IKE SA.
- **Next Payload (8 bits):** Indicates the type of the first payload in the message; payloads are discussed in the next subsection.
- **Major Version (4 bits):** Indicates major version of IKE in use.
- **Minor Version (4 bits):** Indicates minor version in use.
- **Exchange Type (8 bits):** Indicates the type of exchange; these are discussed later in this section.
- **Flags (8 bits):** Indicates specific options set for this IKE exchange. Three bits are defined so far. The initiator bit indicates whether this packet is sent by

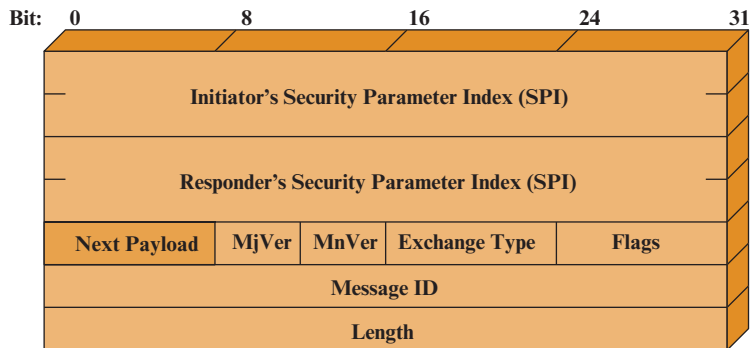

(a) IKE header



(b) Generic Payload header

Figure 20.12 IKE Formats

the SA initiator. The version bit indicates whether the transmitter is capable of using a higher major version number than the one currently indicated. The response bit indicates whether this is a response to a message containing the same message ID.

- **Message ID (32 bits):** Used to control retransmission of lost packets and matching of requests and responses.
- **Length (32 bits):** Length of total message (header plus all payloads) in octets.

IKE PAYLOAD TYPES All IKE payloads begin with the same generic payload header shown in Figure 20.12b. The Next Payload field has a value of 0 if this is the last payload in the message; otherwise its value is the type of the next payload. The Payload Length field indicates the length in octets of this payload, including the generic payload header.

The critical bit is 0 if the sender wants the recipient to skip this payload if it does not understand the payload type code in the Next Payload field of the previous payload. It is set to 1 if the sender wants the recipient to reject this entire message if it does not understand the payload type.

Table 20.3 summarizes the payload types defined for IKE and lists the fields, or parameters, that are part of each payload. The **SA payload** is used to begin the establishment of an SA. The payload has a complex, hierarchical structure. The payload may contain multiple proposals. Each proposal may contain multiple protocols. Each protocol may contain multiple transforms. And each transform may contain multiple attributes. These elements are formatted as substructures within the payload as follows.

Table 20.3 IKE Payload Types

Type	Parameters
Security Association	Proposals
Key Exchange	DH Group #, Key Exchange Data
Identification	ID Type, ID Data
Certificate	Cert Encoding, Certificate Data
Certificate Request	Cert Encoding, Certification Authority
Authentication	Auth Method, Authentication Data
Nonce	Nonce Data
Notify	Protocol-ID, SPI Size, Notify Message Type, SPI, Notification Data
Delete	Protocol-ID, SPI Size, # of SPIs, SPI (one or more)
Vendor ID	Vendor ID
Traffic Selector	Number of TSs, Traffic Selectors
Encrypted	IV, Encrypted IKE payloads, Padding, Pad Length, ICV
Configuration	CFG Type, Configuration Attributes
Extensible Authentication Protocol	EAP Message

- **Proposal:** This substructure includes a proposal number, a protocol ID (AH, ESP, or IKE), an indicator of the number of transforms, and then a transform substructure. If more than one protocol is to be included in a proposal, then there is a subsequent proposal substructure with the same proposal number.
- **Transform:** Different protocols support different transform types. The transforms are used primarily to define cryptographic algorithms to be used with a particular protocol.
- **Attribute:** Each transform may include attributes that modify or complete the specification of the transform. An example is key length.

The **Key Exchange payload** can be used for a variety of key exchange techniques, including Oakley, Diffie–Hellman, and the RSA-based key exchange used by PGP. The Key Exchange data field contains the data required to generate a session key and is dependent on the key exchange algorithm used.

The **Identification payload** is used to determine the identity of communicating peers and may be used for determining authenticity of information. Typically the ID Data field will contain an IPv4 or IPv6 address.

The **Certificate payload** transfers a public-key certificate. The Certificate Encoding field indicates the type of certificate or certificate-related information.

At any point in an IKE exchange, the sender may include a **Certificate Request** payload to request the certificate of the other communicating entity. The payload may list more than one certificate type that is acceptable and more than one certificate authority that is acceptable.

The **Authentication** payload contains data used for message authentication purposes. The authentication method types so far defined are RSA digital signature, shared-key message integrity code, and DSS digital signature.

The **Nonce** payload contains random data used to guarantee liveness during an exchange and to protect against replay attacks.

The **Notify** payload contains either error or status information associated with this SA or this SA negotiation.

The **Delete** payload indicates one or more SAs that the sender has deleted from its database and that therefore are no longer valid.

The **Vendor ID** payload contains a vendor-defined constant. The constant is used by vendors to identify and recognize remote instances of their implementations. This mechanism allows a vendor to experiment with new features while maintaining backward compatibility.

The **Traffic Selector** payload allows peers to identify packet flows for processing by IPsec services.

The **Encrypted** payload contains other payloads in encrypted form. The encrypted payload format is similar to that of ESP. It may include an IV if the encryption algorithm requires it and an ICV if authentication is selected.

The **Configuration** payload is used to exchange configuration information between IKE peers.

The **Extensible Authentication Protocol (EAP)** payload allows IKE SAs to be authenticated using EAP.

20.6 KEY TERMS, REVIEW QUESTIONS, AND PROBLEMS

Key Terms

IP Security (IPsec) IPv4	IPv6 replay attack	transport mode tunnel mode
-----------------------------	-----------------------	-------------------------------

Review Questions

- 20.1 List and briefly describe some benefits of IPsec.
- 20.2 List and briefly define different categories of IPsec documents.
- 20.3 What is the key concept of the security association (SA) in an IP Security Policy?
- 20.4 What is the difference between transport mode and tunnel mode?
- 20.5 What are the types of secret key algorithms used in IPsec?
- 20.6 Why does ESP include a padding field?
- 20.7 What are the parameters that identify an SA in any IP packet?
- 20.8 What are the roles of the Oakley key determination protocol and ISAKMP in IPsec?

Problems

- 20.1 Describe and explain each of the entries in Table 20.1.
- 20.2 Draw a figure similar to Figure 20.6 for AH.
- 20.3 Summarize the major security services provided by the Encapsulating Security Payload (ESP) and the Internet Key Exchange (IKE) together with the respective RFCs involved for each standard.
- 20.4 In terms of outbound processing in a security policy database (SPD), how important is it to determine an SA? How many SAs can we have in each IP packet to filter outgoing traffic?
- 20.5 Suppose that the next replay window spans from 120 to 530.
 - a. If the next incoming authenticated packet has sequence number 340, what will the receiver do with the packet, and what will be the parameters of the window after that?
 - b. If instead the next incoming authenticated packet has sequence number 598, what will the receiver do with the packet, and what will be the parameters of the window after that?
 - c. If instead the next incoming authenticated packet has sequence number 110, what will the receiver do with the packet, and what will be the parameters of the window after that?

- 20.6** When tunnel mode is used, a new outer IP header is constructed. For both IPv4 and IPv6, indicate the relationship of each outer IP header field and each extension header in the outer packet to the corresponding field or extension header of the inner IP packet. That is, indicate which outer values are derived from inner values and which are constructed independently of the inner values.
- 20.7** End-to-end authentication and encryption are desired between two hosts. Draw figures similar to Figure 20.6 that show each of the following.
- Transport adjacency with encryption applied before authentication.
 - A transport SA bundled inside a tunnel SA with encryption applied before authentication.
 - A transport SA bundled inside a tunnel SA with authentication applied before encryption.
- 20.8** The IPsec architecture document states that when two transport mode SAs are bundled to allow both AH and ESP protocols on the same end-to-end flow, only one ordering of security protocols seems appropriate: performing the ESP protocol before performing the AH protocol. Why is this approach recommended rather than authentication before encryption?
- 20.9** Describe the association between an IKE header and the Key Exchange Payload with the aid of a diagram, detailing each field of both.
- 20.10** What is the process to transfer a public key certificate using IKE? What happens when an SA is deleted?

CHAPTER 21

NETWORK ENDPOINT SECURITY

21.1 Firewalls

- Firewall Characteristics
- Types of Firewalls
- DMZ Networks

21.2 Intrusion Detection Systems

- Basic Principles
- Approaches to Intrusion Detection
- Host-Based Intrusion Detection Techniques
- Network-Based Intrusion Detection Systems

21.3 Malicious Software

- Types of Malware
- Malware Defense

21.4 Distributed Denial of Service Attacks

- DDoS Attack Description
- Constructing the Attack Network
- DDoS Countermeasures

21.5 Key Terms, Review Questions, and Problems

LEARNING OBJECTIVES

After studying this chapter, you should be able to:

- ◆ Explain the role of firewalls as part of a computer and network security strategy.
- ◆ List the key characteristics of firewalls.
- ◆ Understand the relative merits of various choices for firewall location and configurations.
- ◆ Understand the basic principles and requirements for intrusion detection.
- ◆ Discuss the key features of intrusion detection systems.
- ◆ Describe some of the main categories of malicious software.
- ◆ Present an overview of the key elements of malware defense.
- ◆ Discuss the nature of a distributed denial of service attack.

This chapter focuses on security threats directed at endpoints, such as servers, workstations, and mobile devices, that are attached to an enterprise network or the Internet. Detailed discussion of the countermeasures implemented on the endpoints, such as antivirus software, is beyond our scope. Instead, this chapter looks at endpoint security from a network perspective.

The chapter begins with a discussion of firewalls. Firewalls can be an effective means of protecting a local system or network of systems from network-based security threats while at the same time affording access to the outside world via wide area networks and the Internet.

Section 21.2 deals with intrusion detection systems, while Section 21.3 provides an overview of malicious software. The last section discusses the important topic of distributed denial of service.

21.1 FIREWALLS

The firewall is an important complement to host-based security services such as intrusion detection systems. Typically, a firewall is inserted between the premises network and the Internet to establish a controlled link and to erect an outer security wall or perimeter. The aim of this perimeter is to protect the premises network from Internet-based attacks and to provide a single choke point where security and auditing can be imposed. Firewalls are also deployed internal to the enterprise network to segregate portions of the network.

The firewall provides an additional layer of defense, insulating internal systems from external networks or other parts of the internal network. This follows the classic military doctrine of “defense in depth,” which is just as applicable to IT security.

Firewall Characteristics

[BELL94] lists the following design goals for a firewall:

1. All traffic from inside to outside, and vice versa, must pass through the firewall. This is achieved by physically blocking all access to the local network except via the firewall. Various configurations are possible, as explained later in this section.
2. Only authorized traffic, as defined by the local security policy, will be allowed to pass. Various types of firewalls are used, which implement various types of security policies, as explained later in this chapter.
3. The firewall itself is immune to penetration. This implies the use of a hardened system with a secured operating system (OS). Trusted computer systems are suitable for hosting a firewall and are often required in government applications.

In general terms, there are four techniques that firewalls use to control access and enforce the site's security policy. Originally, firewalls focused primarily on service control, but they have since evolved to provide all four:

- **Service control:** Determines the types of Internet services that can be accessed, inbound or outbound. The firewall may filter traffic on the basis of IP address, protocol, or port number; may provide proxy software that receives and interprets each service request before passing it on; or may host the server software itself, such as a Web or mail service.
- **Direction control:** Determines the direction in which particular service requests may be initiated and allowed to flow through the firewall.
- **User control:** Controls access to a service according to which user is attempting to access it. This feature is typically applied to users inside the firewall perimeter (local users). It may also be applied to incoming traffic from external users; the latter requires some form of secure authentication technology, such as the one provided in IPsec.
- **Behavior control:** Controls how particular services are used. For example, the firewall may filter email to eliminate spam, or it may enable external access to only a portion of the information on a local Web server.

Before proceeding to the details of firewall types and configurations, it is best to summarize what one can expect from a firewall. The following capabilities are within the scope of a firewall:

1. A firewall defines a single choke point that keeps unauthorized users out of the protected network, prohibits potentially vulnerable services from entering or leaving the network, and provides protection from various kinds of IP spoofing and routing attacks. The use of a single choke point simplifies security management because security capabilities are consolidated on a single system or set of systems.
2. A firewall provides a location for monitoring security-related events. Audits and alarms can be implemented on the firewall system.

3. A firewall is a convenient platform for several Internet functions that are not security related. These include a network address translator, which maps local addresses to Internet addresses, and a network management function that audits or logs Internet usage.
4. A firewall can serve as the platform for implementing virtual private networks. This is discussed in the following section.

Firewalls have their limitations, including the following:

1. The firewall cannot protect against attacks that bypass the firewall. Internal systems may have dial-out capability to connect to an ISP. An internal LAN may support a modem pool that provides dial-in capability for traveling employees and telecommuters.
2. The firewall may not protect fully against internal threats, such as a disgruntled employee or an employee who unwittingly cooperates with an external attacker.
3. An improperly secured wireless LAN may be accessed from outside the organization. An internal firewall that separates portions of an enterprise network cannot guard against wireless communications between local systems on different sides of the internal firewall.
4. A laptop, smartphone, or portable storage device may be used and infected outside the corporate network, and then connected and used internally.

Types of Firewalls

A firewall may act as a packet filter. It can operate as a positive filter, allowing to pass only packets that meet specific criteria, or as a negative filter, rejecting any packet that meets certain criteria. Depending on the type of firewall, it may examine one or more protocol headers in each packet, the payload of each packet, or the pattern generated by a sequence of packets. In this section, we look at the principal types of firewalls.

PACKET FILTERING FIREWALL A packet filtering firewall applies a set of rules to each incoming and outgoing IP packet and then forwards or discards the packet (Figure 21.1b). The firewall is typically configured to filter packets going in both directions (from and to the internal network). Filtering rules are based on information contained in a network packet:

- **Source IP address:** The IP address of the system that originated the IP packet (e.g., 192.178.1.1)
- **Destination IP address:** The IP address of the system the IP packet is trying to reach (e.g., 192.168.1.2)
- **Source and destination transport-level address:** The transport-level (e.g., TCP or UDP) port number, which defines applications such as SNMP or TELNET
- **IP protocol field:** Defines the transport protocol
- **Interface:** For a firewall with three or more ports, which interface of the firewall the packet came from or which interface of the firewall the packet is destined for

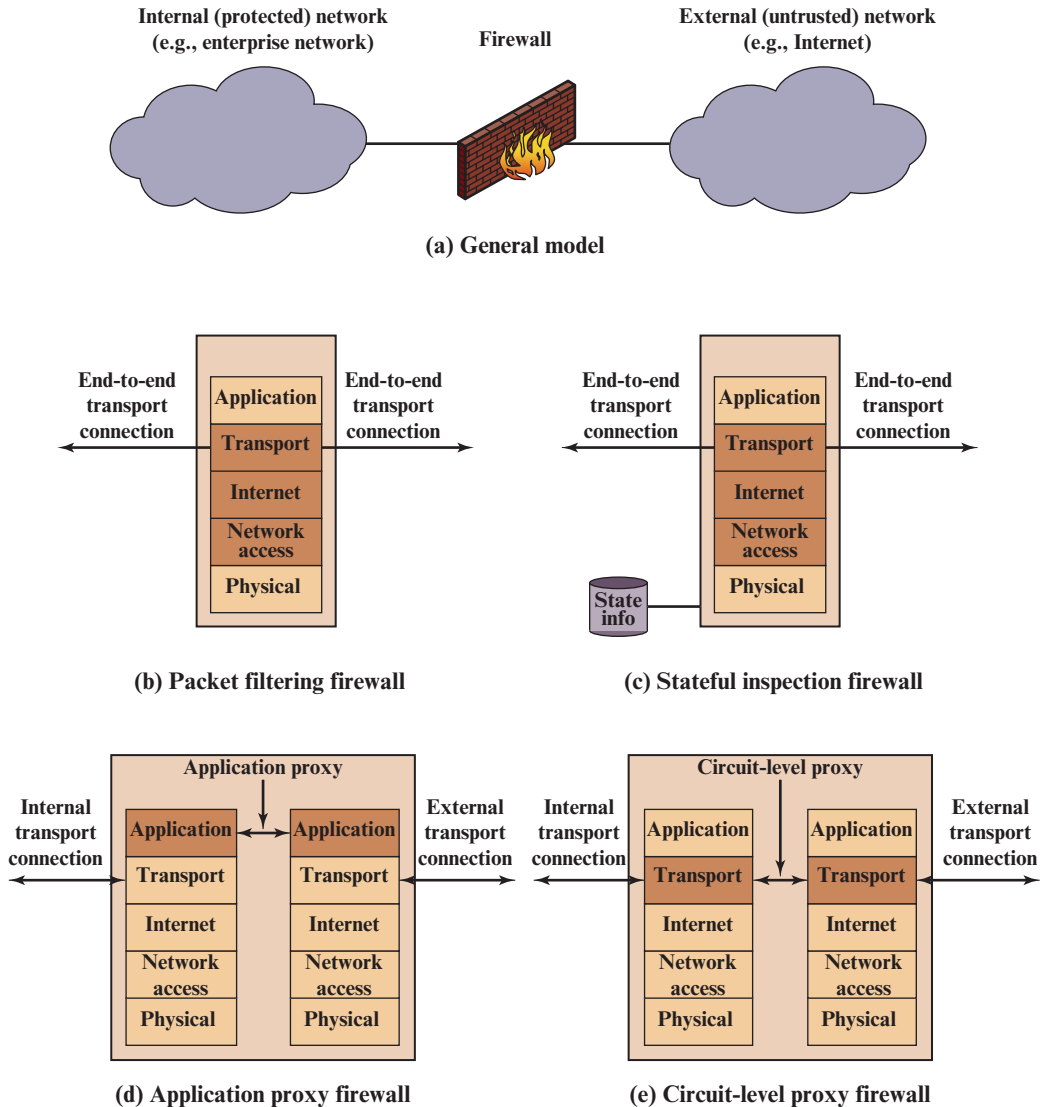

Figure 21.1 Types of Firewalls

The packet filter is typically set up as a list of rules based on matches to fields in the IP or TCP header. If there is a match to one of the rules, that rule is invoked to determine whether to forward or discard the packet. If there is no match to any rule, then a default action is taken. Two default policies are possible:

- **Default = discard:** That which is not expressly permitted is prohibited.
- **Default = forward:** That which is not expressly prohibited is permitted.

The default = discard policy is more conservative. Initially, everything is blocked, and services must be added on a case-by-case basis. This policy is more visible to

users, who are more likely to see the firewall as a hindrance. However, this is the policy likely to be preferred by businesses and government organizations. Further, visibility to users diminishes as rules are created. The default = forward policy increases ease of use for end users but provides reduced security; the security administrator must, in essence, react to each new security threat as it becomes known. This policy may be used by generally more open organizations, such as universities.

Figure 21.2 gives some examples of packet filtering rule sets. In each set, the rules are applied top to bottom. The “*” in a field is a wildcard designator that matches everything. We assume that the default = discard policy is in force. The rule sets can be described as follows:

- A. Inbound mail is allowed (port 25 is for SMTP incoming), but only to a gateway host. However, packets from a particular external host, SPIGOT, are blocked because that host has a history of sending massive files in e-mail messages.
- B. This is an explicit statement of the default policy. All rule sets include this rule implicitly as the last rule.

Rule Set A

action	Ourhost	port	theirhost	port	comment
block	*	*	SPIGOT	*	we don't trust these people
allow	OUR-GW	25	*	*	connection to our SMTP port

Rule Set B

action	Ourhost	port	theirhost	port	comment
block	*	*	*	*	default

Rule Set C

action	Ourhost	port	theirhost	port	comment
allow	*	*	*	25	connection to their SMTP port

Rule Set D

action	Src	port	dest	port	flags	comment
allow	{our hosts}	*	*	25		our packets to their SMTP port
allow	*	25	*	*	ACK	their replies

Rule Set E

action	Src	port	dest	port	flags	comment
allow	{our hosts}	*	*	*		our outgoing calls
allow	*	*	*	*	ACK	replies to our calls
allow	*	*	*	>1024		traffic to nonservers

Figure 21.2 Packet-Filtering Example

- C. This rule set is intended to specify that any inside host can send mail to the outside. A TCP packet with a destination port of 25 is routed to the SMTP server on the destination machine. The problem with this rule is that the use of port 25 for SMTP receipt is only a default; an outside machine could be configured to have some other application linked to port 25. As this rule is written, an attacker could gain access to internal machines by sending packets with a TCP source port number of 25.
- D. This rule set achieves the intended result that was not achieved in C. The rules take advantage of a feature of TCP connections. Once a connection is set up, the ACK flag of a TCP segment is set to acknowledge segments sent from the other side. Thus, this rule set states that it allows IP packets where the source IP address is one of a list of designated internal hosts and the destination TCP port number is 25. It also allows incoming packets with a source port number of 25 that include the ACK flag in the TCP segment. Note that we explicitly designate source and destination systems to define these rules explicitly.
- E. This rule set is one approach to handling FTP connections. With FTP, two TCP connections are used: a control connection to set up the file transfer and a data connection for the actual file transfer. The data connection uses a different port number that is dynamically assigned for the transfer. Most servers, and hence most attack targets, use low-numbered ports; most outgoing calls tend to use a higher-numbered port, typically above 1023. Thus, this rule set allows
 - Packets that originate internally
 - Reply packets to a connection initiated by an internal machine
 - Packets destined for a high-numbered port on an internal machine

This scheme requires that the systems be configured so that only the appropriate port numbers are in use.

Rule set E points out the difficulty in dealing with applications at the packet filtering level. Another way to deal with FTP and similar applications is either stateful filters or an application-level gateway, both described subsequently in this section.

One advantage of a packet filtering firewall is its simplicity. Also, packet filters typically are transparent to users and are very fast. However, packet filters have the following weaknesses:

- Because packet filter firewalls do not examine upper-layer data, they cannot prevent attacks that employ application-specific vulnerabilities or functions. For example, if a packet filter firewall cannot block specific application commands and if a packet filter firewall allows a given application, all functions available within that application will be permitted.
- Because of the limited information available to the firewall, the logging functionality present in packet filter firewalls is limited. Packet filter logs normally contain the same information used to make access control decisions (source address, destination address, and traffic type).
- Most packet filter firewalls do not support advanced user authentication schemes. Once again, this limitation is mostly due to the lack of upper-layer functionality by the firewall.

- Packet filter firewalls are generally vulnerable to attacks and exploits that take advantage of problems within the TCP/IP specification and protocol stack, such as *network layer address spoofing*. Many packet filter firewalls cannot detect a network packet in which the OSI Layer 3 addressing information has been altered. Spoofing attacks are generally employed by intruders to bypass the security controls implemented in a firewall platform.
- Finally, due to the small number of variables used in access control decisions, packet filter firewalls are susceptible to security breaches caused by improper configurations. In other words, it is easy to accidentally configure a packet filter firewall to allow traffic types, sources, and destinations that should be denied based on an organization's information security policy.

Some of the attacks that can be made on packet filtering firewalls and the appropriate countermeasures are the following:

- **IP address spoofing:** The intruder transmits packets from the outside with a source IP address field containing an address of an internal host. The attacker hopes that the use of a spoofed address will allow penetration of systems that employ simple source address security, in which packets from specific trusted internal hosts are accepted. The countermeasure is to discard packets with an inside source address if the packet arrives on an external interface. In fact, this countermeasure is often implemented at the router external to the firewall.
- **Source routing attacks:** The source station specifies the route that a packet should take as it crosses the Internet, in the hopes that this will bypass security measures that do not analyze the source routing information. The countermeasure is to discard all packets that use this option.
- **Tiny fragment attacks:** The intruder uses the IP fragmentation option to create extremely small fragments and force the TCP header information into a separate packet fragment. This attack is designed to circumvent filtering rules that depend on TCP header information. Typically, a packet filter will make a filtering decision on the first fragment of a packet. All subsequent fragments of that packet are filtered out solely on the basis that they are part of the packet whose first fragment was rejected. The attacker hopes that the filtering firewall examines only the first fragment and that the remaining fragments are passed through. A tiny fragment attack can be defeated by enforcing a rule that the first fragment of a packet must contain a predefined minimum amount of the transport header. If the first fragment is rejected, the filter can remember the packet and discard all subsequent fragments.

STATEFUL INSPECTION FIREWALLS A traditional packet filter makes filtering decisions on an individual packet basis and does not take into consideration any higher-layer context. To understand what is meant by *context* and why a traditional packet filter is limited with regard to context, a little background is needed. Most standardized applications that run on top of TCP follow a client/server model. For example, for the Simple Mail Transfer Protocol (SMTP), email is transmitted from a client system to a server system. The client system generates new email messages, typically from user input. The server system accepts incoming email messages and

places them in the appropriate user mailboxes. SMTP operates by setting up a TCP connection between client and server, in which the TCP server port number, which identifies the SMTP server application, is 25. The TCP port number for the SMTP client is a number between 1024 and 65535 that is generated by the SMTP client.

In general, when an application that uses TCP creates a session with a remote host, it creates a TCP connection in which the TCP port number for the remote (server) application is a number less than 1024 and the TCP port number for the local (client) application is a number between 1024 and 65535. The numbers less than 1024 are the “well-known” port numbers and are assigned permanently to particular applications (e.g., 25 for server SMTP). The numbers between 1024 and 65535 are generated dynamically and have temporary significance only for the lifetime of a TCP connection.

A simple packet filtering firewall must permit inbound network traffic on all these high-numbered ports for TCP-based traffic to occur. This creates a vulnerability that can be exploited by unauthorized users.

A stateful inspection packet firewall tightens up the rules for TCP traffic by creating a directory of outbound TCP connections, as shown in Table 21.1. There is an entry for each currently established connection. The packet filter will now allow incoming traffic to high-numbered ports only for those packets that fit the profile of one of the entries in this directory.

A stateful packet inspection firewall reviews the same packet information as a packet filtering firewall, but also records information about TCP connections (Figure 21.1c). Some stateful firewalls also keep track of TCP sequence numbers to prevent attacks that depend on the sequence number, such as session hijacking. Some even inspect limited amounts of application data for some well-known protocols like FTP, IM, and SIPS commands, in order to identify and track related connections.

APPLICATION-LEVEL GATEWAY An application-level gateway, also called an **application proxy**, acts as a relay of application-level traffic (Figure 21.1d). The user contacts the gateway using a TCP/IP application, such as Telnet or FTP, and the gateway asks the user for the name of the remote host to be accessed. When the user responds and provides a valid user ID and authentication information, the gateway

Table 21.1 Example Stateful Firewall Connection State Table

Source Address	Source Port	Destination Address	Destination Port	Connection State
192.168.1.100	1030	210.9.88.29	80	Established
192.168.1.102	1031	216.32.42.123	80	Established
192.168.1.101	1033	173.66.32.122	25	Established
192.168.1.106	1035	177.231.32.12	79	Established
223.43.21.231	1990	192.168.1.6	80	Established
219.22.123.32	2112	192.168.1.6	80	Established
210.99.212.18	3321	192.168.1.6	80	Established
24.102.32.23	1025	192.168.1.6	80	Established
223.21.22.12	1046	192.168.1.6	80	Established

contacts the application on the remote host and relays TCP segments containing the application data between the two endpoints. If the gateway does not implement the proxy code for a specific application, the service is not supported and cannot be forwarded across the firewall. Further, the gateway can be configured to support only specific features of an application that the network administrator considers acceptable while denying all other features.

Application-level gateways tend to be more secure than packet filters. Rather than trying to deal with the numerous possible combinations that are to be allowed and forbidden at the TCP and IP level, the application-level gateway need only scrutinize a few allowable applications. In addition, it is easy to log and audit all incoming traffic at the application level.

A prime disadvantage of this type of gateway is the additional processing overhead on each connection. In effect, there are two spliced connections between the end users, with the gateway at the splice point, and the gateway must examine and forward all traffic in both directions.

CIRCUIT-LEVEL GATEWAY A fourth type of firewall is the circuit-level gateway or **circuit-level proxy** (Figure 21.1e). This can be a stand-alone system or it can be a specialized function performed by an application-level gateway for certain applications. As with an application gateway, a circuit-level gateway does not permit an end-to-end TCP connection; rather, the gateway sets up two TCP connections, one between itself and a TCP user on an inner host and one between itself and a TCP user on an outside host. Once the two connections are established, the gateway typically relays TCP segments from one connection to the other without examining the contents. The security function consists of determining which connections will be allowed.

A typical use of circuit-level gateways is a situation in which the system administrator trusts the internal users. The gateway can be configured to support application-level or proxy service on inbound connections and circuit-level functions for outbound connections. In this configuration, the gateway can incur the processing overhead of examining incoming application data for forbidden functions but does not incur that overhead on outgoing data.

DMZ Networks

Figure 21.3 suggests the most common distinction, that between an internal and an external firewall. An external firewall is placed at the edge of a local or enterprise network, just inside the boundary router that connects to the Internet or some wide area network (WAN). One or more internal firewalls protect the bulk of the enterprise network. Between these two types of firewalls are one or more networked devices in a region referred to as a demilitarized zone (DMZ) network. Systems that are externally accessible but need some protections are usually located on DMZ networks. Typically, the systems in the DMZ require or foster external connectivity, such as a corporate Web site, an email server, or a domain name system (DNS) server.

The external firewall provides a measure of access control and protection for the DMZ systems consistent with their need for external connectivity. The external firewall also provides a basic level of protection for the remainder of the enterprise network. In this type of configuration, internal firewalls serve three purposes:

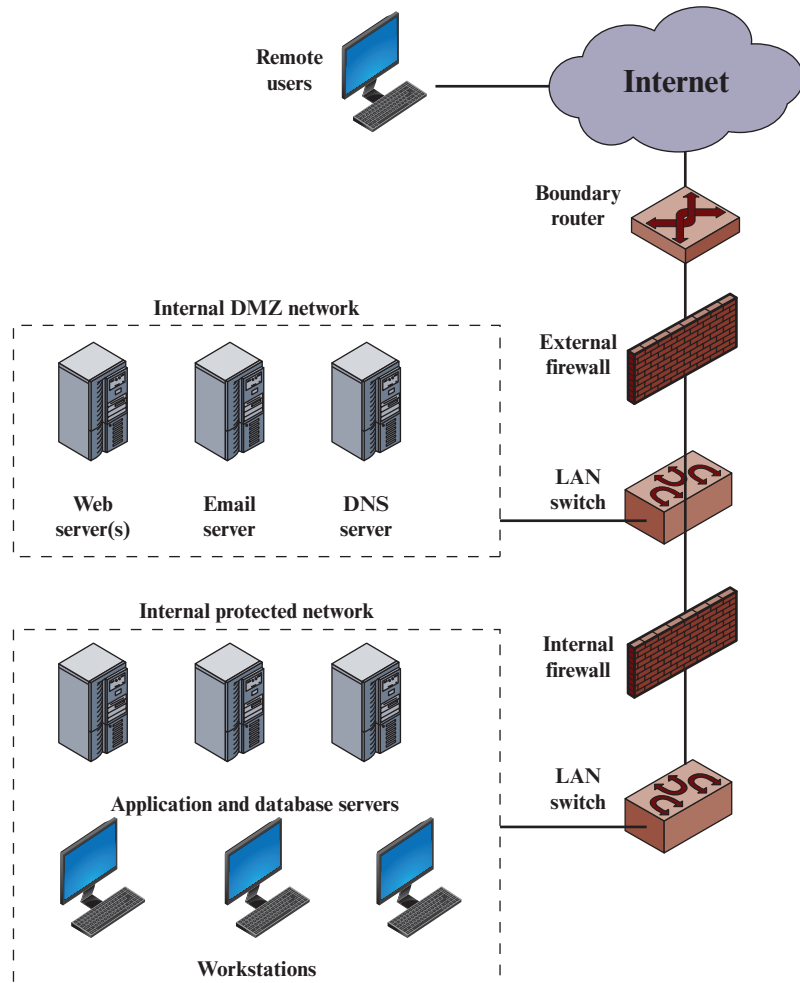

Figure 21.3 Example Firewall Configuration

1. The internal firewall adds more stringent filtering capability, compared to the external firewall, in order to protect enterprise servers and workstations from external attack.
2. The internal firewall provides two-way protection with respect to the DMZ. First, the internal firewall protects the remainder of the network from attacks launched from DMZ systems. Such attacks might originate from worms, rootkits, bots, or other malware lodged in a DMZ system. Second, an internal firewall can protect the DMZ systems from attack from the internal protected network.
3. Multiple internal firewalls can be used to protect portions of the internal network from each other. For example, firewalls can be configured so that internal servers are protected from internal workstations and vice versa. A common practice is to place the DMZ on a different network interface on the external firewall from that used to access the internal networks.

21.2 INTRUSION DETECTION SYSTEMS

It is useful to begin this section by defining the following terms:

- **Intrusion:** Violations of security policy, usually characterized as attempts to affect the confidentiality, integrity, or availability of a computer or network. These violations can come from attackers accessing systems from the Internet or from authorized users of the systems who attempt to overstep their legitimate authorization levels or who use their legitimate access to the system to conduct unauthorized activity.
- **Intrusion detection:** The process of collecting information about events occurring in a computer system or network and analyzing them for signs of intrusions.
- **Intrusion detection system:** Hardware or software products that gather and analyze information from various areas within a computer or a network for the purpose of finding, and providing real-time or near-real-time warning of, attempts to access system resources in an unauthorized manner.

Intrusion detection systems (IDSs) can be classified as follows:

- **Host-based IDS:** Monitors the characteristics of a single host and the events occurring within that host for suspicious activity. This vantage point allows host-based IDSs to determine exactly which processes and user accounts are involved in a particular attack on the OS. Furthermore, unlike network-based IDSs, host-based IDSs can more readily see the intended outcome of an attempted attack, because they can directly access and monitor the data files and system processes usually targeted by attacks.
- **Network-based IDS:** Monitors network traffic for particular network segments or devices and analyzes network, transport, and application protocols to identify suspicious activity.

An IDS comprises three logical components:

- **Sensors:** Sensors are responsible for collecting data. The input for a sensor may be any part of a system that could contain evidence of an intrusion. Types of input to a sensor include network packets, log files, and system call traces. Sensors collect and forward this information to the analyzer.
- **Analyzers:** Analyzers receive input from one or more sensors or from other analyzers. The analyzer is responsible for determining if an intrusion has occurred. The output of this component is an indication that an intrusion has occurred. The output may include evidence supporting the conclusion that an intrusion occurred. The analyzer may provide guidance about what actions to take as a result of the intrusion.
- **User interface:** The user interface to an IDS enables a user to view output from the system or control the behavior of the system. In some systems, the user interface may equate to a manager, director, or console component.

Basic Principles

Authentication facilities, access control facilities, and firewalls all play a role in countering intrusions. Another line of defense is intrusion detection, and this has been the focus of much research in recent years. This interest is motivated by a number of considerations, including the following:

1. If an intrusion is detected quickly enough, the intruder can be identified and ejected from the system before any damage is done or any data are compromised. Even if the detection is not sufficiently timely to preempt the intruder, the sooner that the intrusion is detected, the less the amount of damage and the more quickly that recovery can be achieved.
2. An effective IDS can serve as a deterrent, thus acting to prevent intrusions.
3. Intrusion detection enables the collection of information about intrusion techniques that can be used to strengthen intrusion prevention measures.

Approaches to Intrusion Detection

Intrusion detection assumes that the behavior of the intruder differs from that of a legitimate user in ways that can be quantified. Of course, we cannot expect that there will be a crisp, exact distinction between an attack by an intruder and the normal use of resources by an authorized user. Rather, we must expect that there will be some overlap.

There are two general approaches to intrusion detection: misuse detection and anomaly detection (Figure 21.4).

Misuse detection is based on rules that specify system events, sequences of events, or observable properties of a system that are believed to be symptomatic of security incidents. Misuse detectors use various pattern-matching algorithms, operating on large databases of attack patterns, or *signatures*. An advantage of misuse detection is that it is accurate and generates few false alarms. A disadvantage is that it cannot detect novel or unknown attacks.

Anomaly detection searches for activity that is different from the normal behavior of system entities and system resources. An advantage of anomaly detection is that it is able to detect previously unknown attacks based on an audit of activity. A disadvantage is that there is a significant trade-off between false positives and false negatives. Figure 21.5 suggests, in abstract terms, the nature of the task confronting the designer of an anomaly detection system. Although the typical behavior of an intruder differs from the typical behavior of an authorized user, there is an overlap

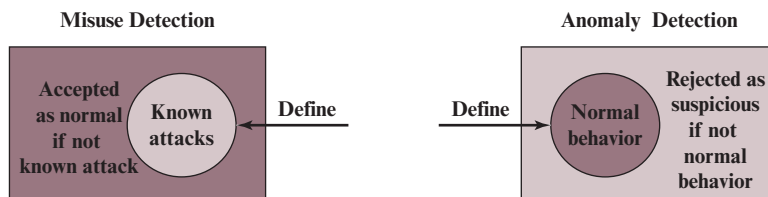

Figure 21.4 Approaches to Intrusion Detection

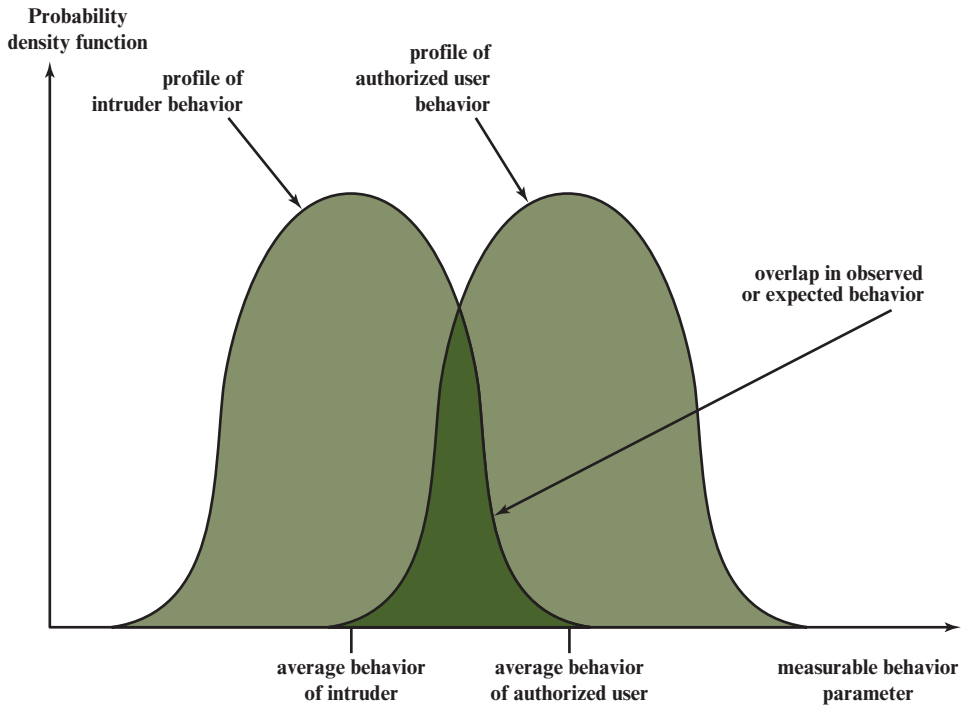

Figure 21.5 Profiles of Behavior of Intruders and Authorized Users

Table 21.2 Test Outcomes

Test Result	Condition A Occurs	Condition A Does Not Occur
Test says “A”	True positive	False positive
Test says “NOT A”	False negative	True negative

in these behaviors. Thus, a loose interpretation of intruder behavior, which will catch more intruders, will also lead to a number of **false positives**, or authorized users identified as intruders. On the other hand, an attempt to limit false positives by a tight interpretation of intruder behavior will lead to an increase in **false negatives**, or intruders not identified as intruders. Thus, there is an element of compromise and art in the practice of anomaly detection.

Table 21.2 clarifies the relationship between the terms false positive, true positive, false negative, and true negative.

Host-Based Intrusion Detection Techniques

Host-based IDSs add a specialized layer of security software to vulnerable or sensitive systems; examples include database servers and administrative systems. The host-based IDS monitors activity on the system in a variety of ways to detect suspicious behavior. In some cases, an IDS can halt an attack before any damage

is done, but its primary purpose is to detect intrusions, log suspicious events, and send alerts.

The primary benefit of a host-based IDS is that it can detect both external and internal intrusions, something that is not possible either with network-based IDSs or firewalls.

Host-based IDSs use one or a combination of anomaly and misuse protection. For anomaly detection, two common strategies are:

- **Threshold detection:** This approach involves defining thresholds, independent of user, for the frequency of occurrence of various events.
- **Profile based:** A profile of the activity of each user is developed and used to detect changes in the behavior of individual accounts.

Network-Based Intrusion Detection Systems

A network-based ID system (NIDS) monitors the traffic on its network segment as a data source. This is generally accomplished by placing the network interface card in promiscuous mode to capture all network traffic that crosses its network segment. Network traffic on other segments, and traffic on other means of communication (like phone lines), can't be monitored by a single NIDS.

NIDS FUNCTION Network-based ID involves looking at the packets on the network as they pass by some sensor. Packets are considered to be of interest if they match a signature. Three primary types of signatures are string signatures, port signatures, and header condition signatures.

String signatures look for a text string that indicates a possible attack. An example string signature for UNIX might be “cat “+ +” >/rhosts”, which if successful, might cause a UNIX system to become extremely vulnerable to network attack. To refine the string signature to reduce the number of false positives, it may be necessary to use a compound string signature. A compound string signature for a common Web server attack might be “cgi-bin” AND “aglimpse” AND “IFS”

Port signatures simply watch for connection attempts to well known, frequently attacked ports. Examples of these ports include telnet (TCP port 23), FTP (TCP port 21/20), SUNRPC (TCP/UDP port 111), and IMAP (TCP port 143). If any of these ports aren't used by the site, then incoming packets to these ports are suspicious.

Header signatures watch for dangerous or illogical combinations in packet headers. The most famous example is WinNuke, where a packet is destined for a NetBIOS port and the Urgent pointer, or Out Of Band pointer is set. This resulted in the “blue screen of death” for Windows systems. Another well-known header signature is a TCP packet with both the SYN and FIN flags set, signifying that the requestor wishes to start and stop a connection at the same time.

NIDS PLACEMENT An NIDS sensor can only see the packets that happen to be carried on the network segment to which it is attached. Accordingly, a NIDS deployment is typically set up as a number of sensors distributed on key network points to passively gather traffic data and feed information on potential threats to a central

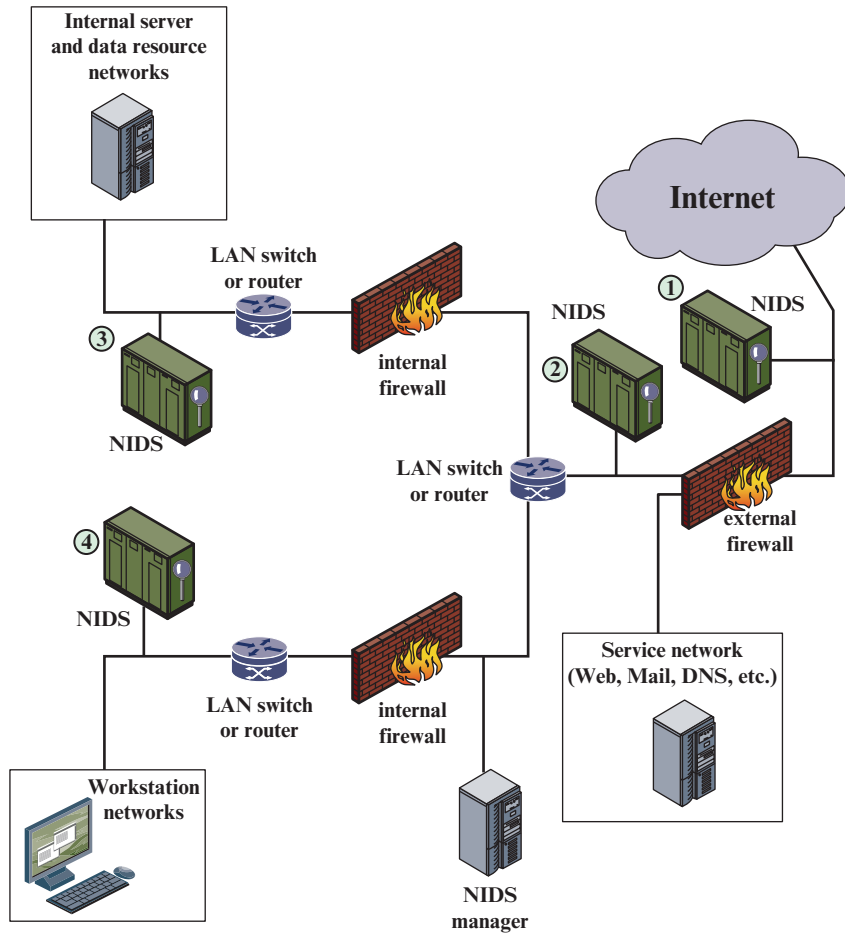

Figure 21.6 Example of NIDS Sensor Deployment

NIDS manager. Figure 21.6 gives examples of NIDS sensor placement. There are four types of locations for the sensors:

1. Outside the main enterprise firewall. Useful for establishing the level of threat for a given enterprise network. Those responsible for winning management support for security efforts can find this placement valuable.
2. In the network DMZ (inside the main firewall but outside internal firewalls). This location can monitor for penetration attempts that target Web and other services generally open to outsiders.
3. Behind internal firewalls, positioned to monitor major backbone networks, such as those that support internal servers and database resources.
4. Behind internal firewalls, positioned to monitor LANs that support user workstations and servers specific to a single department. Locations 3 and 4 in Figure 21.6 can monitor for more specific attacks at network segments, as well as attacks originating from inside the organization.

21.3 MALICIOUS SOFTWARE

Malicious software, commonly called **malware**, is perhaps the most significant security threat to organizations. NIST SP 800-83 (*Guide to Malware Incident Prevention and Handling for Desktops and Laptops*) defines malware as “a program that is covertly inserted into another program with the intent to destroy data, run destructive or intrusive programs, or otherwise compromise the confidentiality, integrity, or availability of the victim’s data, applications, or operating system.” Hence, malware can pose a threat to application programs, to utility programs, such as editors and compilers, and to kernel-level programs. Malware can also be used on compromised or malicious Web sites and servers, or in especially crafted spam emails or other messages, which aim to trick users into revealing sensitive personal information.

Types of Malware

There is a growing variety of types of malware, most of which fits into one of the following broad categories:

- **Virus:** A computer program that can copy itself and infect a computer without permission or knowledge of the user. A virus might corrupt or delete data on a computer, use email programs to spread itself to other computers, or even erase everything on a hard disk. It can replicate itself and can attach to another program. The program to which the virus attaches itself is known as host.
- **Worm:** A self-replicating, self-propagating, self-contained program that uses networking mechanisms to spread itself. The main differences between viruses and worms is that the worms can self-replicate and propagate without human interaction and that the worm does not integrate into existing code. Worms target systems and applications that have known vulnerabilities.
- **Trojan Horse:** A computer program that appears to have a useful function, but also has a hidden and potentially malicious function that evades security mechanisms, sometimes by exploiting legitimate authorizations of a system entity that invokes the program. As the name suggests, the purpose of a Trojan horse is to make a malicious program appear like a legitimate program. Trojan horse can monitor users’ action, steal users’ data, and can open a backdoor for the attackers.
- **Spyware:** Software that is secretly or surreptitiously installed into an information system to gather information on individuals or organizations without their knowledge.
- **Rootkit:** A set of tools used by an attacker after gaining root-level access to a host to conceal the attacker’s activities on the host and permit the attacker to maintain root-level access to the host through covert means.
- **Backdoor:** An undocumented way of gaining access to a computer system. Typically, a backdoor is a program that has the ability to bypass a system’s security control, allowing an attacker to access the system stealthily. Backdoors are usually installed by the attackers or by a malware program.

- **Mobile code:** Software (e.g., script, macro, or other portable instruction) that can be shipped unchanged to a heterogeneous collection of platforms and execute with identical semantics.
- **Bot:** Also known as a zombie. Program that is installed on a system to launch attacks on other machines. For example, a distributed denial-of-service (DDoS) attack involves traffic from a number of infected bot machines to a single target, to overwhelm the resources of the target machine. A collection of bots that act in concert is referred to as a **botnet**.

Malware Defense

Approaches to malware defense are commonly categorized along two dimensions, as shown in Figure 21.7. In terms of time scale, there are two categories:

- **Real-time and Near-real-time:** Approaches in this category involve monitoring and, if possible, blocking malware-related attacks as they are happening or very soon thereafter. These approaches typically also involve remedial action, such as removing malware and reporting the incident.
- **Post-compromise:** Approaches in this category involve analysis of incident reports and traffic patterns to aid in improving security controls.

The remainder of this section provides an overview of the approaches shown in Figure 21.7.

NETWORK TRAFFIC ANALYSIS Network traffic analysis involves monitoring traffic flows to detect potentially malicious activity. Such monitors are often placed at the boundary of the enterprise network to the outside world, such as the Internet or private networks. Monitors can also be placed on internal network devices or near server endpoints.

As with intrusion detection, traffic analysis can involve misuse detection (signature detection) or anomaly detection. As an example of misuse detection, a dramatic surge in traffic at any point likely indicates that a DDoS attack is underway. For anomaly detection, network security software needs to collect and maintain profiles of typical network traffic patterns, and then monitor current traffic for

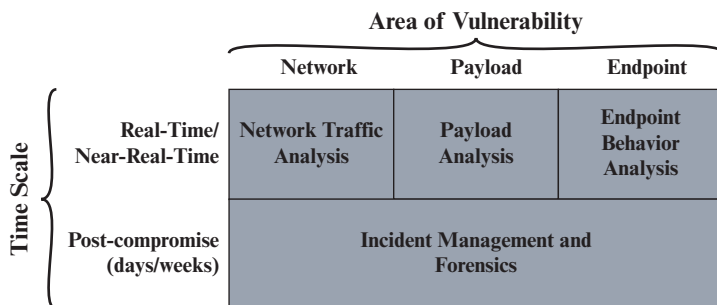

Figure 21.7 Five Elements of Malware Defense

significant deviation from normal behavior. For example, anomalous DNS (Domain Name System) traffic is a good indicator of botnet activity.

PAYLOAD ANALYSIS The term payload refers to the data encapsulated within packets that has meaning to endpoint applications. As with traffic analysis, payload analysis is a real-time or near-real-time activity. It involves looking for known malicious payloads (signature detection) or looking for payload patterns that are anomalous. One useful technique for payload analysis is the use of a sandbox environment, which quarantines the payload until the analysis is done. This enables a payload analysis system to observe the behavior of payloads in motion, such as when they cross the network perimeter, and to either flag suspicious payloads or block them outright.

ENDPOINT BEHAVIOR ANALYSIS This category involves a wide variety of tools and approaches implemented at the endpoint. Antivirus software uses signature and anomaly detection techniques to identify malware and prevent it from executing on the host system. Application whitelisting, which restricts application execution to only known good applications is also employed. At the system software level, application containers can isolate applications and files in virtual containers to prevent damage.

INCIDENT MANAGEMENT Information security incident management as consisting of processes for detecting, reporting, assessing, responding to, dealing with, and learning from information security incidents.

Key elements of incident management include:

- **Data collection:** In a typical use case, an incident management system must be able to touch any number of different systems: firewalls, proxy servers, data bases, intrusion detection and prevention systems, OSs, routers, switches, access control systems, etc. Some of these may share similar logging and alert functions, but frequently there is significant variation in the format, protocol and information provided.
- **Data aggregation:** The aggregator serves as a consolidating resource before data is sent to be correlated or retained.
- **Data normalization:** Normalization is the process of resolving different representations of the same types of data into a similar format in a common database.
- **Correlation:** Event correlation is the function of linking multiple security events or alerts, typically within a given time window and across multiple systems, to identify anomalous activity that would not be evident from any singular event.
- **Alerting:** When data is gathered or identified that trigger certain responses, such as alerts or potential security problems, tools can activate certain protocols to alert users, like notifications sent to the dashboard, an automated email or text message.
- **Reporting/Compliance:** Protocols can be established that automatically collect data necessary for compliance with company, organizational, and government policies.

The goal is to analyze the security incidents both for purposes of improving system security and for updating signatures and anomaly profiles used for detection. This process applies both to malware-related attacks and to intrusions.

FORENSICS NIST SP 800-96 (*Guide to Integrating Forensic Techniques into Incident Response*) defines computer forensics, or digital forensics, as the identification, collection, examination, and analysis of data while preserving the integrity of the information and maintaining a strict chain of custody for the data. Computer forensics seeks to answer a number of questions including the following:

- What happened?
- When did the events occur?
- In what order did the events occur?
- What was the cause of these events?
- Who caused these events to occur?
- What enabled these events to take place?
- What was affected? How much was it affected?

Most security incidents do not require a forensic investigation but can be dealt with by the ordinary incident management process. But more serious incidents may warrant the more in-depth analysis of a forensic investigation.

21.4 DISTRIBUTED DENIAL OF SERVICE ATTACKS

A denial-of-service (DoS) attack is an attempt to prevent legitimate users of a service from using that service. When this attack comes from a single host or network node, then it is simply referred to as a DoS attack. A more serious threat is posed by a DDoS attack. DDoS attacks make computer systems inaccessible by flooding servers, networks, or even end-user systems with useless traffic so that legitimate users can no longer gain access to those resources. In a typical DDoS attack, a large number of compromised hosts are amassed to send useless packets.

This section is concerned with DDoS attacks. First, we look at the nature and types of attacks. Next, we examine methods by which an attacker is able to recruit a network of hosts for attack launch. Finally, this section looks at countermeasures.

DDoS Attack Description

A DDoS attack attempts to consume the target's resources so that it cannot provide service. One way to classify DDoS attacks is in terms of the type of resource that is consumed. Broadly speaking, the resource consumed is either an internal host resource on the target system or data transmission capacity in the local network to which the target is attacked.

A simple example of an internal resource attack is the SYN flood attack. Figure 21.8a shows the steps involved:

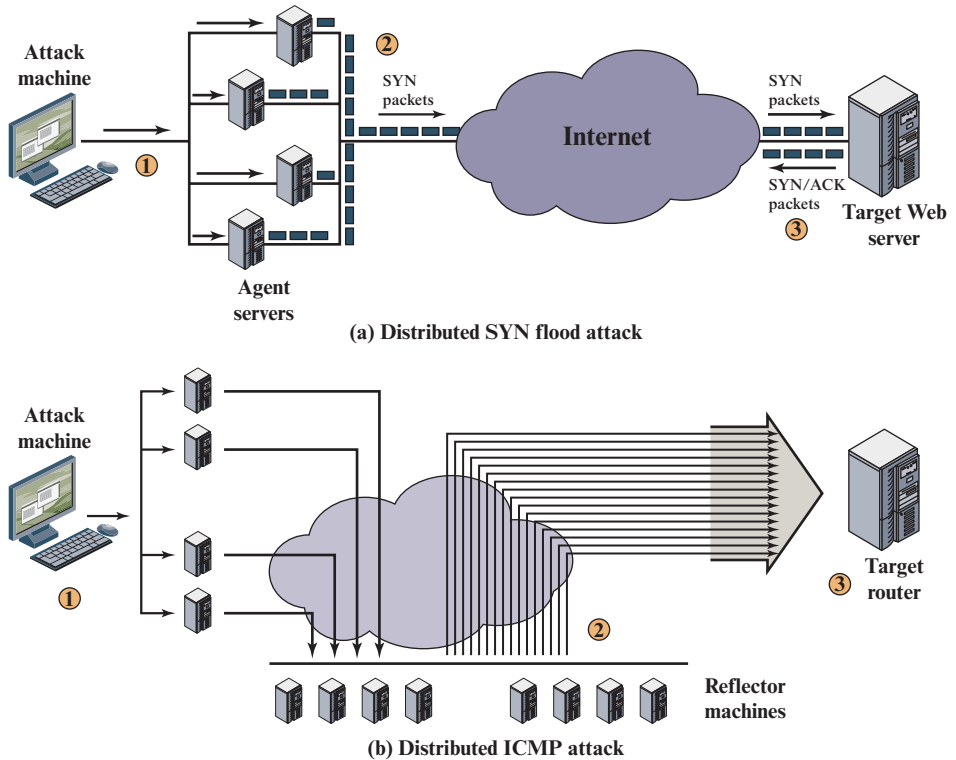

Figure 21.8 Examples of Simple DDoS Attacks

1. The attacker takes control of multiple hosts over the Internet, instructing them to contact the target Web server.
2. The agent hosts begin sending TCP/IP SYN (synchronize/initialization) packets, with erroneous return IP address information, to the target.
3. Each SYN packet is a request to open a TCP connection. For each such packet, the Web server responds with a SYN/ACK (synchronize/acknowledge) packet, trying to establish a TCP connection with a TCP entity at a spurious IP address. The Web server maintains a data structure for each SYN request waiting for a response back and becomes bogged down as more traffic floods in. The result is that legitimate connections are denied while the victim machine is waiting to complete bogus “half-open” connections.

The TCP state data structure is a popular internal resource target but by no means the only one. Other possibilities include the following:

1. An intruder may attempt to use up available data structures that are used by the OS to manage processes, such as process table entries and process control information entries. The attack can be quite simple, such as a program that forks new processes repeatedly.

2. An intruder may attempt to allocate to itself large amounts of disk space by a variety of straightforward means. These include generating numerous emails, forcing errors that trigger audit trails, and placing files in shareable areas.

Figure 21.8b illustrates an example of an attack that consumes data transmission resources. The following steps are involved:

1. The attacker takes control of multiple hosts over the Internet, instructing them to send ICMP ECHO packets¹ with the target's spoofed IP address to a group of hosts that act as reflectors, as described subsequently.
2. Nodes at the bounce site receive multiple spoofed requests and respond by sending echo reply packets to the target site.
3. The target's router is flooded with packets from the bounce site, leaving no data transmission capacity for legitimate traffic.

Another way to classify DDoS attacks is as either direct or reflector DDoS attacks. In a direct DDoS attack (Figure 21.9a), the attacker is able to implant zombie software on a number of sites distributed throughout the Internet. Often, the DDoS attack involves two levels of zombie machines: primary zombies and agent zombies. The hosts of both machines have been infected with malicious code. The attacker coordinates and triggers the primary zombies, which in turn coordinate and trigger the agent zombies. The use of two levels of zombies makes it more difficult to trace the attack back to its source and provides for a more resilient network of attackers.

A reflector DDoS attack adds another layer of machines (Figure 21.9b). In this type of attack, the agent zombies construct packets requiring a response that contain the target's IP address as the source IP address in the packet's IP header. These packets are sent to uninfected machines known as reflectors. The uninfected machines respond with packets directed at the target machine. A reflector DDoS attack can easily involve more machines and more traffic than a direct DDoS attack and hence be more damaging. Further, tracing back the attack or filtering out the attack packets is more difficult because the attack comes from widely dispersed uninfected machines.

Constructing the Attack Network

The first step in a DDoS attack is for the attacker to infect a number of machines with zombie software that will ultimately be used to carry out the attack. The essential ingredients in this phase of the attack are the following:

1. Software that can carry out the DDoS attack. The software must be able to run on a large number of machines, must be able to conceal its existence, must be able to communicate with the attacker or have some sort of time-triggered mechanism, and must be able to launch the intended attack toward the target.

¹The Internet Control Message Protocol (ICMP) is an IP-level protocol for the exchange of control packets between a router and a host or between hosts. The ECHO packet requires the recipient to respond with an echo reply to check that communication is possible between entities.

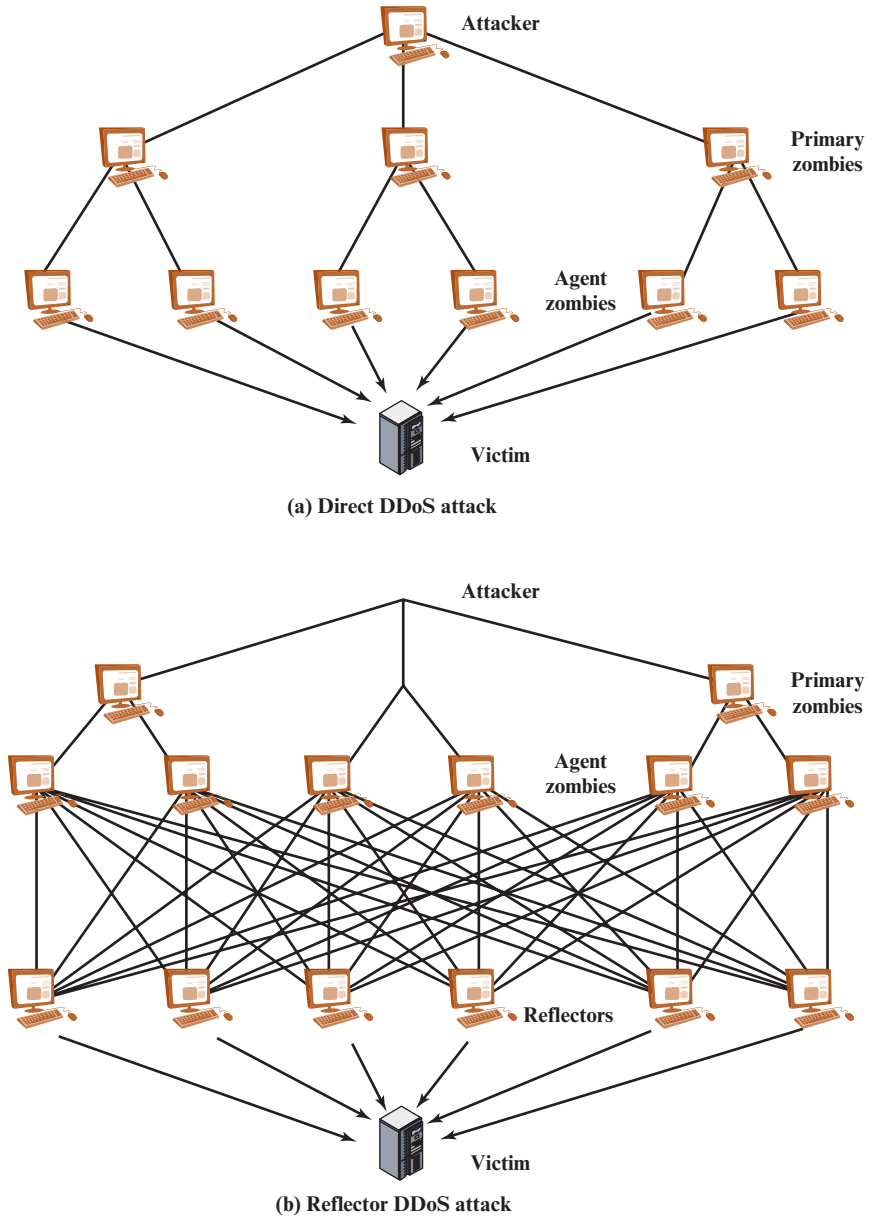

Figure 21.9 Types of Flooding-Based DDoS Attacks

2. A vulnerability in a large number of systems. The attacker must become aware of a vulnerability that many system administrators and individual users have failed to patch and that enables the attacker to install the zombie software.
3. A strategy for locating vulnerable machines, a process known as scanning.

In the scanning process, the attacker first seeks out a number of vulnerable machines and infects them. Then, typically, the zombie software that is installed in the infected machines repeats the same scanning process, until a large distributed network of infected machines is created. [MIRK04] lists the following types of scanning strategies:

- **Random:** Each compromised host probes random addresses in the IP address space, using a different seed. This technique produces a high volume of Internet traffic, which may cause generalized disruption even before the actual attack is launched.
- **Hit list:** The attacker first compiles a long list of potential vulnerable machines. This can be a slow process done over a long period to avoid detection that an attack is underway. Once the list is compiled, the attacker begins infecting machines on the list. Each infected machine is provided with a portion of the list to scan. This strategy results in a very short scanning period, which may make it difficult to detect that infection is taking place.
- **Topological:** This method uses information contained on an infected victim machine to find more hosts to scan.
- **Local subnet:** If a host can be infected behind a firewall, that host then looks for targets in its own local network. The host uses the subnet address structure to find other hosts that would otherwise be protected by the firewall.

DDoS Countermeasures

In general, there are three lines of defense against DDoS attacks:

- **Attack prevention and preemption (before the attack):** These mechanisms enable the victim to endure attack attempts without denying service to legitimate clients. Techniques include enforcing policies for resource consumption and providing backup resources available on demand. In addition, prevention mechanisms modify systems and protocols on the Internet to reduce the possibility of DDoS attacks.
- **Attack detection and filtering (during the attack):** These mechanisms attempt to detect the attack as it begins and respond immediately. This minimizes the impact of the attack on the target. Detection involves looking for suspicious patterns of behavior. Response involves filtering out packets likely to be part of the attack.
- **Attack source traceback and identification (during and after the attack):** This is an attempt to identify the source of the attack as a first step in preventing future attacks. However, this method typically does not yield results fast enough, if at all, to mitigate an ongoing attack.

The challenge in coping with DDoS attacks is the sheer number of ways in which they can operate. Thus, DDoS countermeasures must evolve with the threat.

21.5 KEY TERMS, REVIEW QUESTIONS, AND PROBLEMS

Key Terms

anomaly detection application proxy botnet	circuit-level proxy false negatives false positives	malware misuse detection
--	---	-----------------------------

Review Questions

- 21.1** List three design goals for a firewall.
- 21.2** List four techniques used by firewalls to control access and enforce a security policy.
- 21.3** What information is used by a typical packet filtering firewall?
- 21.4** What are some weaknesses of a packet filtering firewall?
- 21.5** What is the difference between a packet filtering firewall and a stateful inspection firewall?
- 21.6** What is an application-level gateway?
- 21.7** What is a circuit-level gateway?
- 21.8** What is a DMZ network and what types of systems would you expect to find on such networks?
- 21.9** What is the difference between an internal and an external firewall?
- 21.10** Explain the difference between host-based and network-based intrusion detection systems.
- 21.11** What are the main logical components of an IDS?
- 21.12** What are the two main approaches to intrusion detection?
- 21.13** List the main categories of malicious software.
- 21.14** Explain the difference between network traffic analysis, payload analysis, and end-point behavior analysis.
- 21.15** What is a distributed denial-of-service system?

Problems

- 21.1** As was mentioned in Section 21.1, one approach to defeating the tiny fragment attack is to enforce a minimum length of the transport header that must be contained in the first fragment of an IP packet. If the first fragment is rejected, all subsequent fragments can be rejected. However, the nature of IP is such that fragments may arrive out of order. Thus, an intermediate fragment may pass through the filter before the initial fragment is rejected. How can this situation be handled?
- 21.2** In an IPv4 packet, the size of the payload in the first fragment, in octets, is equal to Total Length $- (4 \times \text{IHL})$. If this value is less than the required minimum (8 octets for TCP), then this fragment and the entire packet are rejected. Suggest an alternative method of achieving the same result using only the Fragment Offset field.
- 21.3** RFC 791, the IPv4 protocol specification, describes a reassembly algorithm that results in new fragments overwriting any overlapped portions of previously received fragments. Given such a reassembly implementation, an attacker could construct a series of packets in which the lowest (zero-offset) fragment would contain innocuous data (and thereby be passed by administrative packet filters), and in which some subsequent packet having a nonzero offset would overlap TCP header information (destination

Table 21.3 Sample Packet Filter Firewall Ruleset

	Source Address	Source Port	Destination Address	Destination Port	Action
1	Any	Any	192.168.1.0	> 1023	Allow
2	192.168.1.1	Any	Any	Any	Deny
3	Any	Any	192.168.1.1	Any	Deny
4	192.168.1.0	Any	Any	Any	Allow
5	Any	Any	192.168.1.2	SMTP	Allow
6	Any	Any	192.168.1.3	HTTP	Allow
7	Any	Any	Any	Any	Deny

port, for instance) and cause it to be modified. The second packet would be passed through most filter implementations because it does not have a zero fragment offset. Suggest a method that could be used by a packet filter to counter this attack.

21.4 Table 21.3 shows a sample of a packet filter firewall ruleset for an imaginary network of IP address that range from 192.168.1.0 to 192.168.1.254. Describe the effect of each rule.

21.5 SMTP (Simple Mail Transfer Protocol) is the standard protocol for transferring mail between hosts over TCP. A TCP connection is set up between a user agent and a server program. The server listens on TCP port 25 for incoming connection requests. The user end of the connection is on a TCP port number above 1023. Suppose you wish to build a packet filter rule set allowing inbound and outbound SMTP traffic. You generate the following rule set:

Rule	Direction	Src Addr	Dest Addr	Protocol	Dest Port	Action
A	In	External	Internal	TCP	25	Permit
B	Out	Internal	External	TCP	>1023	Permit
C	Out	Internal	External	TCP	25	Permit
D	In	External	Internal	TCP	>1023	Permit
E	Either	Any	Any	Any	Any	Deny

- Describe the effect of each rule.
- Your host in this example has IP address 172.16.1.1. Someone tries to send email from a remote host with IP address 192.168.3.4. If successful, this generates an SMTP dialogue between the remote user and the SMTP server on your host consisting of SMTP commands and mail. Additionally, assume that a user on your host tries to send email to the SMTP server on the remote system. Four typical packets for this scenario are as shown:

Packet	Direction	Src Addr	Dest Addr	Protocol	Dest Port	Action
1	In	192.168.3.4	172.16.1.1	TCP	25	?
2	Out	172.16.1.1	192.168.3.4	TCP	1234	?
3	Out	172.16.1.1	192.168.3.4	TCP	25	?
4	In	192.168.3.4	172.16.1.1	TCP	1357	?

Indicate which packets are permitted or denied and which rule is used in each case.

- Someone from the outside world (10.1.2.3) attempts to open a connection from port 5150 on a remote host to the Web proxy server on port 8080 on one of your

local hosts (172.16.3.4), in order to carry out an attack. Typical packets are as follows:

Packet	Direction	Src Addr	Dest Addr	Protocol	Dest Port	Action
5	In	10.1.2.3	172.16.3.4	TCP	8080	?
6	Out	172.16.3.4	10.1.2.3	TCP	5150	?

Will the attack succeed? Give details.

- 21.6** To provide more protection, the rule set from the preceding problem is modified as follows:

Rule	Direction	Src Addr	Dest Addr	Protocol	Src Port	Dest Port	Action
A	In	External	Internal	TCP	>1023	25	Permit
B	Out	Internal	External	TCP	25	>1023	Permit
C	Out	Internal	External	TCP	>1023	25	Permit
D	In	External	Internal	TCP	25	>1023	Permit
E	Either	Any	Any	Any	Any	Any	Deny

- a. Describe the change.
 - b. Apply this new rule set to the same six packets of the preceding problem. Indicate which packets are permitted or denied and which rule is used in each case.
- 21.7** A hacker uses port 25 as the client port on his or her end to attempt to open a connection to your Web proxy server.
- a. The following packets might be generated:

Packet	Direction	Src Addr	Dest Addr	Protocol	Src Port	Dest Port	Action
7	In	10.1.2.3	172.16.3.4	TCP	25	8080	?
8	Out	172.16.3.4	10.1.2.3	TCP	8080	25	?

Explain why this attack will succeed, using the rule set of the preceding problem.

- b. When a TCP connection is initiated, the ACK bit in the TCP header is not set. Subsequently, all TCP headers sent over the TCP connection have the ACK bit set. Use this information to modify the rule set of the preceding problem to prevent the attack just described.
- 21.8** A common management requirement is that “all external Web traffic must flow via the organization’s Web proxy.” However, that requirement is easier stated than implemented. Discuss the various problems and issues, possible solutions, and limitations supporting this requirement. In particular, consider issues such as identifying exactly what constitutes “Web traffic” and how it may be monitored, given the large range of ports and various protocols used by Web browsers and servers.
- 21.9** Consider the threat of “theft/breach of proprietary or confidential information held in key data files on the system.” One method by which such a breach might occur is the accidental/deliberate emailing of information to a user outside to the organization. A possible countermeasure to this is to require all external email to be given a sensitivity tag (classification if you like) in its subject and for external e-mail to have the lowest sensitivity tag. Discuss how this measure could be implemented in a firewall and what components and architecture would be needed to do this.
- 21.10** In the context of an IDS, we define a false positive to be an alarm generated by an IDS in which the IDS alerts to a condition that is actually benign. A false negative occurs when an IDS fails to generate an alarm when an alert-worthy condition is in effect.

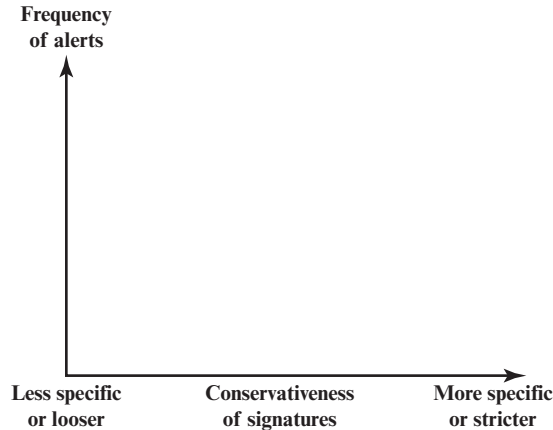

Using the above diagram, depict two curves that roughly indicate false positives and false negatives, respectively.

- 21.11** The overlapping area of the two probability density functions of Figure 21.5 represents the region in which there is the potential for false positives and false negatives. Further, Figure 21.5 is an idealized and not necessarily representative depiction of the relative shapes of the two density functions. Suppose there is 1 actual intrusion for every 1000 authorized users, and the overlapping area covers 1% of the authorized users and 50% of the intruders.
- Sketch such a set of density functions and argue that this is not an unreasonable depiction.
 - What is the probability that an event that occurs in this region is that of an authorized user? Keep in mind that 50% of all intrusions fall in this region.
- 21.12** An example of a host-based intrusion detection tool is the tripwire program. This is a file integrity checking tool that scans files and directories on the system on a regular basis and notifies the administrator of any changes. It uses a protected database of cryptographic checksums for each file checked and compares this value with that recomputed on each file as it is scanned. It must be configured with a list of files and directories to check, and what changes, if any, are permissible to each. It can allow, for example, log files to have new entries appended, but not for existing entries to be changed. What are the advantages and disadvantages of using such a tool? Consider the problem of determining which files should only change rarely, which files may change more often and how, and which change frequently and hence cannot be checked. Hence consider the amount of work in both the configuration of the program and on the system administrator monitoring the responses generated.
- 21.13** A taxicab was involved in a fatal hit-and-run accident at night. Two cab companies, the Green and the Blue, operate in the city. You are told that:
- 85% of the cabs in the city are Green and 15% are Blue.
 - A witness identified the cab as Blue.

The court tested the reliability of the witness under the same circumstances that existed on the night of the accident and concluded that the witness was correct in identifying the color of the cab 80% of the time. What is the probability that the cab involved in the incident was Blue rather than Green?

- 21.14** The question arises as to whether it is possible to develop a program that can analyze a piece of software to determine if it is a virus. Consider that we have a program D that is supposed to be able to do that. That is, for any program P , if we run $D(P)$, the result returned is TRUE (P is a virus) or FALSE (P is not a virus). Now consider the following program:

```
Program CV:=  
{...  
main-program:=  
{if D(CV) then goto next:  
else infect-executable;  
}  
next:  
}
```

In the preceding program, `infect-executable` is a module that scans memory for executable programs and replicates itself in those programs. Determine if D can correctly decide whether CV is a virus.

CHAPTER 22

CLOUD SECURITY

22.1 Cloud Computing

- Cloud Computing Elements
- Cloud Service Models
- Cloud Deployment Models
- Cloud Computing Reference Architecture

22.2 Cloud Security Concepts

22.3 Cloud Security Risks and Countermeasures

- The STRIDE Threat Model
- Data Breaches
- Weak Identity, Credential, and Access Management
- Insecure APIs
- System Vulnerabilities
- Account Hijacking
- Malicious Insiders
- Advanced Persistent Threats
- Data Loss
- Insufficient Due Diligence
- Abuse and Nefarious Use of Cloud Services
- Denial-of-Service
- Shared Technology Vulnerabilities

22.4 Cloud Security As A Service

22.5 An Open-Source Cloud Security Module

22.6 Key Terms and Review Questions

LEARNING OBJECTIVES

After studying this chapter, you should be able to:

- ◆ Present an overview of cloud computing concepts.
- ◆ List and define the principal cloud services.
- ◆ List and define the cloud deployment models.
- ◆ Explain the NIST cloud computing reference architecture.
- ◆ Understand the unique security issues related to cloud computing.
- ◆ Describe Cloud Security as a Service.
- ◆ Understand the OpenStack security module for cloud security.

The two most significant developments in computing in recent years are cloud computing and the Internet of Things (IoT). In both cases, operating systems, cryptographic algorithms, and security protocols tailored to the specific requirements of these environments are evolving. This chapter surveys security issues related to cloud computing. Chapter 23 covers IoT.

This chapter begins with an overview of the concepts of cloud computing, followed by a discussion of cloud security.

22.1 CLOUD COMPUTING

There is an increasingly prominent trend in many organizations to move a substantial portion or even all information technology (IT) operations to an Internet-connected infrastructure known as enterprise cloud computing. This section provides an overview of cloud computing.

Cloud Computing Elements

NIST defines cloud computing, in NIST SP-800-145 (*The NIST Definition of Cloud Computing*), as follows:

Cloud computing: A model for enabling ubiquitous, convenient, on-demand network access to a shared pool of configurable computing resources (e.g., networks, servers, storage, applications, and services) that can be rapidly provisioned and released with minimal management effort or service provider interaction. This cloud model promotes availability and is composed of five essential characteristics, three service models, and four deployment models.

The definition refers to various models and characteristics, whose relationship is illustrated in Figure 22.1. The essential characteristics of cloud computing include the following:

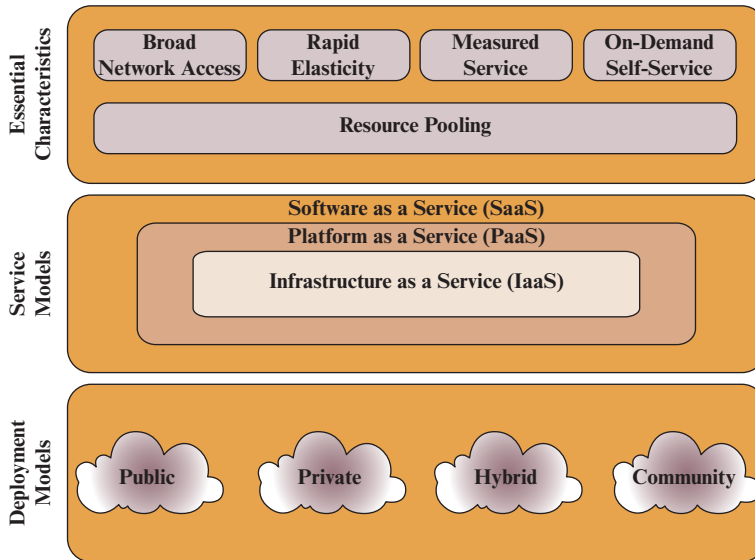

Figure 22.1 Cloud Computing Elements

- **Broad network access:** Capabilities are available over the network and accessed through standard mechanisms that promote use by heterogeneous thin or thick client platforms (e.g., mobile phones, laptops, and PDAs) as well as other traditional or cloud-based software services.
- **Rapid elasticity:** Cloud computing gives you the ability to expand and reduce resources according to your specific service requirement. For example, you may need a large number of server resources for the duration of a specific task. You can then release these resources upon completion of the task.
- **Measured service:** Cloud systems automatically control and optimize resource use by leveraging a metering capability at some level of abstraction appropriate to the type of service (e.g., storage, processing, bandwidth, and active user accounts). Resource usage can be monitored, controlled, and reported, providing transparency for both the provider and consumer of the utilized service.
- **On-demand self-service:** A cloud service consumer (CSC) can unilaterally provision computing capabilities, such as server time and network storage, as needed automatically without requiring human interaction with each service provider. Because the service is on demand, the resources are not permanent parts of your IT infrastructure.
- **Resource pooling:** The provider's computing resources are pooled to serve multiple CSCs using a multi-tenant model, with different physical and virtual resources dynamically assigned and reassigned according to consumer demand. There is a degree of location independence in that the CSC generally has no control or knowledge of the exact location of the provided resources, but may be able to specify location at a higher level of abstraction (e.g., country, state, or data center). Examples of resources include storage, processing,

memory, network bandwidth, and virtual machines. Even private clouds tend to pool resources between different parts of the same organization.

Cloud Service Models

NIST defines three **service models**, which can be viewed as nested service alternatives: software as a service (SaaS), platform as a service (PaaS), and infrastructure as a service (IaaS).

SOFTWARE AS A SERVICE SaaS provides service to customers in the form of software, specifically application software, running on and accessible in the cloud. SaaS follows the familiar model of Web services, in this case applied to cloud resources. SaaS enables the customer to use the cloud provider's applications running on the provider's cloud infrastructure. The applications are accessible from various client devices through a simple interface such as a Web browser. Instead of obtaining desktop and server licenses for software products it uses, an enterprise obtains the same functions from the cloud service. The use of SaaS avoids the complexity of software installation, maintenance, upgrades, and patches. Examples of services at this level are Google Gmail, Microsoft 365, Salesforce, Citrix GoToMeeting, and Cisco WebEx.

Common subscribers to SaaS are organizations that want to provide their employees with access to typical office productivity software, such as document management and email. Individuals also commonly use the SaaS model to acquire cloud resources. Typically, subscribers use specific applications on demand. The cloud provider also usually offers data-related features such as automatic backup and data sharing between subscribers.

PLATFORM AS A SERVICE A PaaS cloud provides service to customers in the form of a platform on which the customer's applications can run. PaaS enables the customer to deploy onto the cloud infrastructure customer-created or acquired applications. A PaaS cloud provides useful software building blocks, plus a number of development tools, such as programming language tools, run-time environments, and other tools that assist in deploying new applications. In effect, PaaS is an operating system in the cloud. PaaS is useful for an organization that wants to develop new or tailored applications while paying for the needed computing resources only as needed and only for as long as needed. Google AppEngine, Engine Yard, Heroku, Microsoft Azure Cloud Services, and Apache Stratos are examples of PaaS.

INFRASTRUCTURE AS A SERVICE With IaaS, the customer has access to the resources of the underlying cloud infrastructure. The cloud service user does not manage or control the resources of the underlying cloud infrastructure but has control over operating systems, deployed applications, and possibly limited control of select networking components (e.g., host firewalls). IaaS provides virtual machines (VMs) and other virtualized hardware and operating systems. IaaS offers the customer processing, storage, networks, and other fundamental computing resources so that the customer is able to deploy and run arbitrary software, which can include operating systems and applications. IaaS enables customers to combine basic computing services, such as number crunching and data storage, to build highly adaptable computer systems.

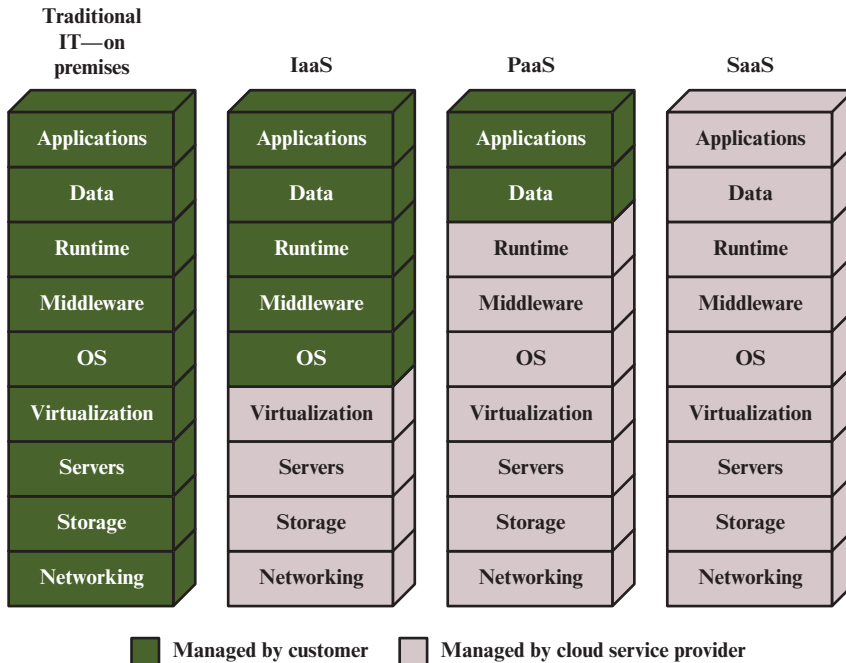

Figure 22.2 Separation of Responsibilities in Cloud Service Models

Typically, customers are able to self-provision this infrastructure, using a Web-based graphical user interface that serves as an IT operations management console for the overall environment. API access to the infrastructure may also be offered as an option. Examples of IaaS are Amazon Elastic Compute Cloud (Amazon EC2), Microsoft Azure, Google Compute Engine (GCE), and Rackspace.

Figure 22.2 compares the functions implemented by the cloud service provider for the three service models.

Cloud Deployment Models

There is an increasingly prominent trend in many organizations to move a substantial portion or even all information technology (IT) operations to enterprise cloud computing. The organization is faced with a range of choices as to cloud ownership and management. Here, we look at the four most prominent deployment models for cloud computing.

PUBLIC CLOUD A **public cloud** infrastructure is made available to the general public or a large industry group and is owned by an organization selling cloud services. The cloud provider is responsible both for the cloud infrastructure and for the control of data and operations within the cloud. A public cloud may be owned, managed, and operated by a business, academic, or government organization, or some combination of them. It exists on the premises of the cloud service provider.

In a public cloud model, all major components are outside the enterprise firewall, located in a multitenant infrastructure. Applications and storage are

made available over the Internet via secured IP, and can be free or offered at a pay-per-usage fee. This type of cloud supplies easy-to-use consumer-type services, such as Amazon and Google on-demand Web applications or capacity; Yahoo mail; and Facebook or LinkedIn social media providing free storage for photographs. While public clouds are inexpensive and scale to meet needs, they typically provide no or lower service level agreements (SLAs) and may not offer the guarantees against data loss or corruption found with private or hybrid cloud offerings. The public cloud is appropriate for CSCs and entities not requiring the same levels of service that are expected within the firewall. Also, the public IaaS clouds do not necessarily provide for restrictions and compliance with privacy laws, which remain the responsibility of the subscriber or corporate end user. In many public clouds, the focus is on the CSC and small and medium businesses where pay-per-use pricing is available, often equating to pennies per gigabyte. Examples of services here might be picture and music sharing, laptop backup, or file sharing.

The major advantage of the public cloud is cost. A subscribing organization only pays for the services and resources it needs and can adjust these as needed. Further, the subscriber has greatly reduced management overhead. The principal concern is security. However, there are a number of public cloud providers that have demonstrated strong security controls and, in fact, such providers may have more resources and expertise to devote to security that would be available in a private cloud.

Figure 22.3 shows in general terms the context of a public cloud used to provide dedicated cloud services to an enterprise. The public cloud provider serves a diverse pool of clients. Any given enterprise's cloud resources are segregated from those used by other clients, but the degree of segregation varies among providers. For example, a provider dedicates a number of virtual machines to a given customer, but a virtual machine for one customer may share the same hardware as virtual machines for other customers.

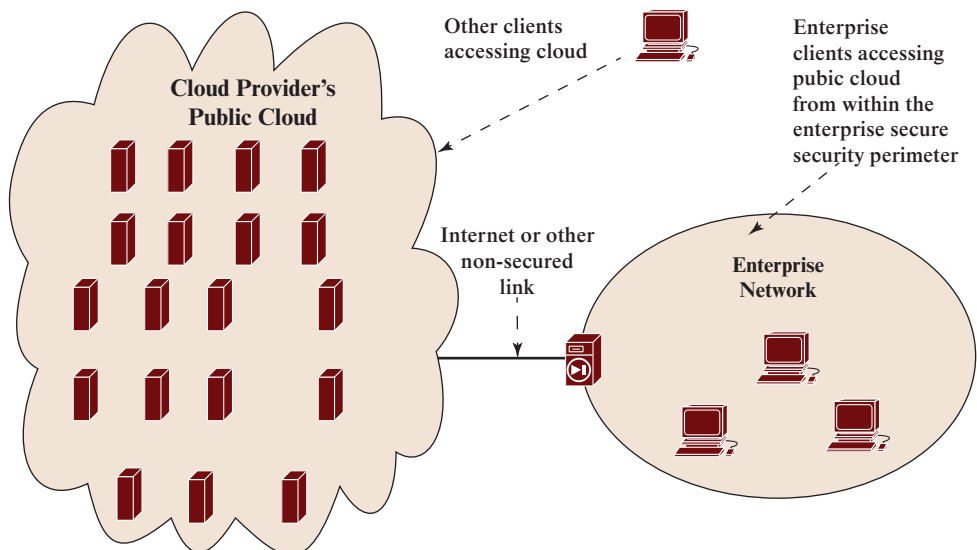

Figure 22.3 Public Cloud Configuration

PRIVATE CLOUD A **private cloud** is implemented within the internal IT environment of the organization. The organization may choose to manage the cloud in house or contract the management function to a third party. Additionally, the cloud servers and storage devices may exist on premise or off premise.

Private clouds can deliver IaaS internally to employees or business units through an intranet or the Internet via a virtual private network (VPN), as well as software (applications) or storage as services to its branch offices. In both cases, private clouds are a way to leverage existing infrastructure, and deliver and chargeback for bundled or complete services from the privacy of the organization's network. Examples of services delivered through the private cloud include database on demand, email on demand, and storage on demand.

A key motivation for opting for a private cloud is security. A private cloud infrastructure offers tighter controls over the geographic location of data storage and other aspects of security. Other benefits include easy resource sharing and rapid deployment to organizational entities.

Figure 22.4 illustrates the two typical private cloud configurations. The private cloud consists of an interconnected collection of servers and data storage devices hosting enterprise applications and data. Local workstations have access to cloud resources from within the enterprise security perimeter. Remote users (e.g., from satellite offices) have access through a secure link, such as a VPN connecting to a secure boundary access controller, such as a firewall. An enterprise may also choose to outsource the private cloud to a cloud provider. The cloud provider establishes and maintains the private cloud, consisting of dedicated infrastructure resources not shared with other cloud provider clients. Typically, a secure link between boundary controllers provides communications between enterprise client systems and the private cloud. This link may be a dedicated leased line or a VPN over the Internet.

COMMUNITY CLOUD A community cloud shares characteristics of private and public clouds. Like a private cloud, a community cloud has restricted access. Like a public cloud, the cloud resources are shared among a number of independent organizations. The organizations that share the community cloud have similar requirements and, typically, a need to exchange data with each other. One example of an industry that is employing the community cloud concept is the health care industry. A community cloud can be implemented to comply with government privacy and other regulations. The community participants can exchange data in a controlled fashion.

The cloud infrastructure may be managed by the participating organizations or a third party and may exist on premise or off premise. In this deployment model, the costs are spread over fewer users than a public cloud (but more than a private cloud), so only some of the cost savings potential of cloud computing are realized.

HYBRID CLOUD The hybrid cloud infrastructure is a composition of two or more clouds (private, community, or public) that remain unique entities but are bound together by standardized or proprietary technology that enables data and application

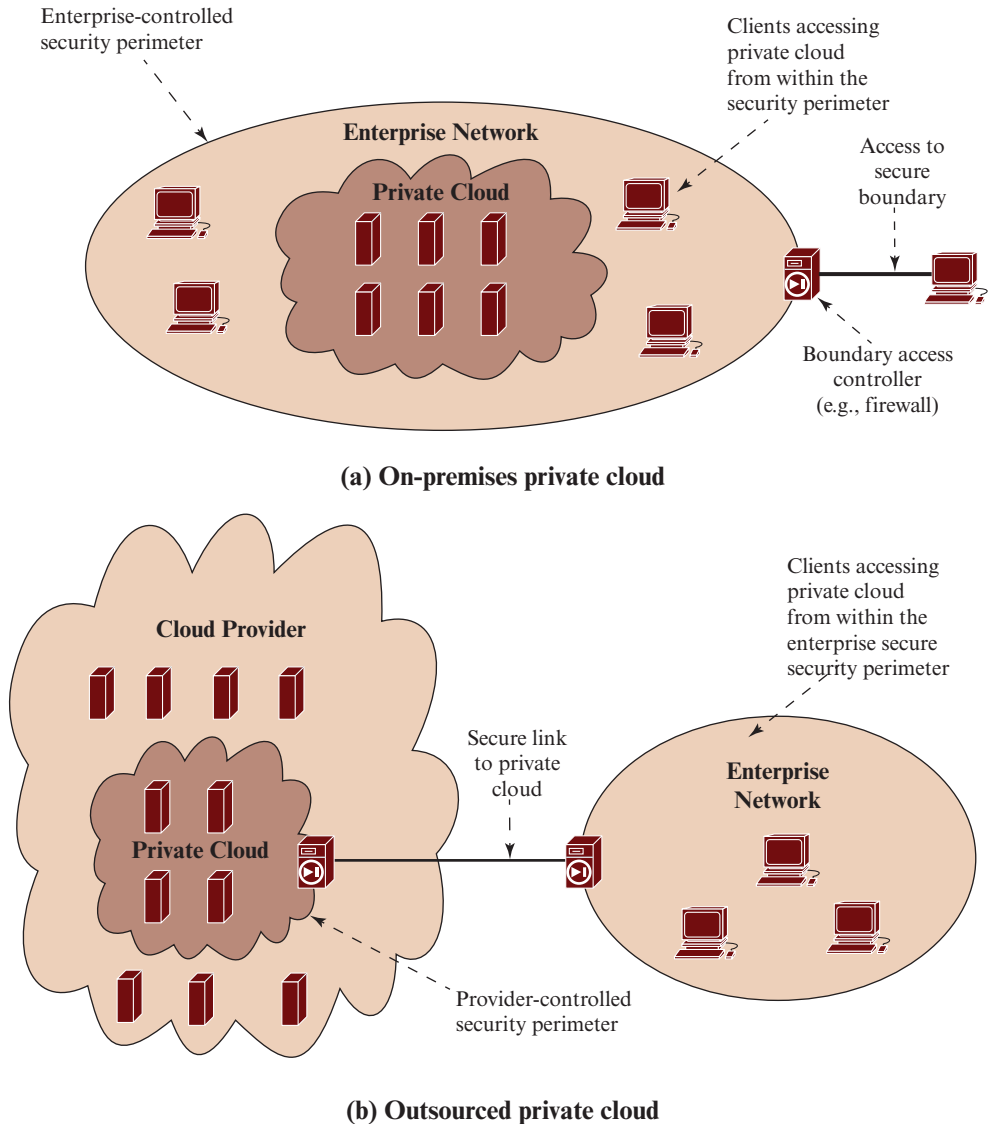

Figure 22.4 Private Cloud Configurations

portability (e.g., cloud bursting for load balancing between clouds). With a hybrid cloud solution, sensitive information can be placed in a private area of the cloud, and less sensitive data can take advantage of the benefits of the public cloud.

A hybrid public/private cloud solution can be particularly attractive for smaller businesses. Many applications for which security concerns are less can be offloaded at considerable cost savings without committing the organization to moving more sensitive data and applications to the public cloud.

Table 22.1 Comparison of Cloud Deployment Models

	Private	Community	Public	Hybrid
Scalability	Limited	Limited	Very high	Very high
Security	Most secure option	Very secure	Moderately secure	Very secure
Performance	Very good	Very good	Low to medium	Good
Reliability	Very high	Very high	Medium	Medium to high
Cost	High	Medium	Low	Medium

Table 22.1 lists some of the relative strengths and weaknesses of the four cloud deployment models.

Cloud Computing Reference Architecture

A cloud computing reference architecture depicts a generic high-level conceptual model for discussing the requirements, structures, and operations of cloud computing. NIST SP 500-292 (*NIST Cloud Computing Reference Architecture*) establishes a reference architecture, described as follows:

The NIST cloud computing reference architecture focuses on the requirements of “what” cloud services provide, not a “how to” design solution and implementation. The reference architecture is intended to facilitate the understanding of the operational intricacies in cloud computing. It does not represent the system architecture of a specific cloud computing system; instead it is a tool for describing, discussing, and developing a system-specific architecture using a common framework of reference.

NIST developed the reference architecture with the following objectives in mind:

- To illustrate and understand the various cloud services in the context of an overall cloud computing conceptual model
- To provide a technical reference for consumers to understand, discuss, categorize, and compare cloud services
- To facilitate the analysis of candidate standards for security, interoperability, and portability and reference implementations

The reference architecture, depicted in Figure 22.5, defines five major actors in terms of the roles and responsibilities:

- **Cloud service customer (CSC):** A person or organization that maintains a business relationship with, and uses service from, cloud providers.
- **Cloud service provider (CSP):** A person, organization, or entity responsible for making a service available to interested parties.
- **Cloud auditor:** A party that can conduct independent assessment of cloud services, information system operations, performance, and security of the cloud implementation.

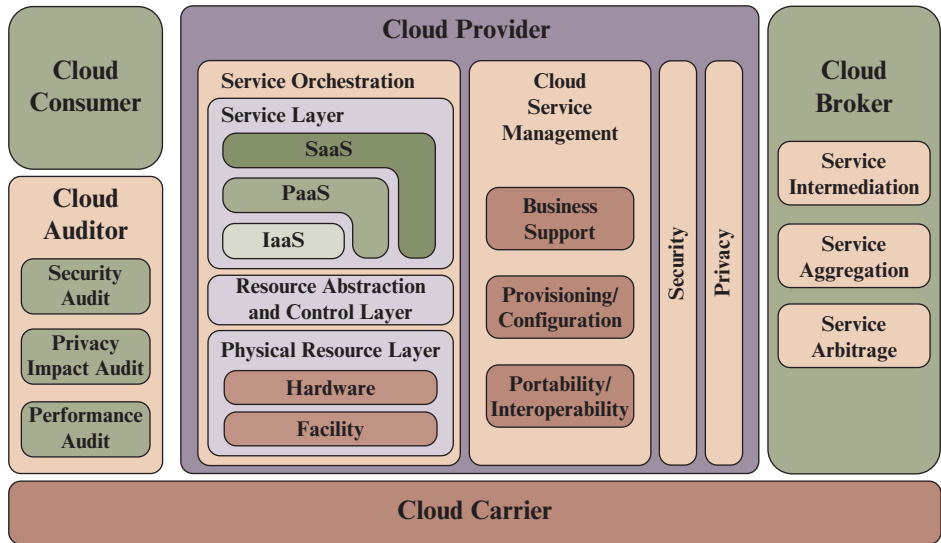

Figure 22.5 NIST Cloud Computing Reference Architecture

- **Cloud broker:** An entity that manages the use, performance, and delivery of cloud services, and negotiates relationships between CPs and cloud consumers.
- **Cloud carrier:** An intermediary that provides connectivity and transport of cloud services from CPs to cloud consumers.

The roles of the CSC and CSP have already been discussed. To summarize, a CSP can provide one or more of the cloud services to meet IT and business requirements of CSCs. For each of the three service models (SaaS, PaaS, IaaS), the CSP provides the storage and processing facilities needed to support that service model, together with a cloud interface for cloud service consumers. For SaaS, the SCP deploys, configures, maintains, and updates the operation of the software applications on a cloud infrastructure so that the services are provisioned at the expected service levels to cloud consumers. The CSCs of SaaS can be organizations that provide their members with access to software applications, end users who directly use software applications, or software application administrators who configure applications for end users.

For PaaS, the CSP manages the computing infrastructure for the platform and runs the cloud software that provides the components of the platform, such as runtime software execution stack, databases, and other middleware components. Cloud consumers of PaaS can employ the tools and execution resources provided by CSPs to develop, test, deploy, and manage the applications hosted in a cloud environment.

For IaaS, the CSP acquires the physical computing resources underlying the service, including the servers, networks, storage, and hosting infrastructure. The IaaS CSC in turn uses these computing resources, such as a virtual computer, for their fundamental computing needs.

The **cloud carrier** is a networking facility that provides connectivity and transport of cloud services between CSCs and CSPs. Typically, a CSP will set up SLAs

with a cloud carrier to provide services consistent with the level of SLAs offered to CSCs, and may require the cloud carrier to provide dedicated and secure connections between CSCs and CSPs.

A **cloud broker** is useful when cloud services are too complex for a cloud consumer to easily manage. Three areas of support can be offered by a cloud broker:

- **Service intermediation:** These are value-added services, such as identity management, performance reporting, and enhanced security.
- **Service aggregation:** The broker combines multiple cloud services to meet consumer needs not specifically addressed by a single CP, or to optimize performance or minimize cost.
- **Service arbitrage:** This is similar to service aggregation except that the services being aggregated are not fixed. Service arbitrage means a broker has the flexibility to choose services from multiple agencies. The cloud broker, for example, can use a credit-scoring service to measure and select an agency with the best score.

A **cloud auditor** can evaluate the services provided by a CP in terms of security controls, privacy impact, performance, and so on. The auditor is an independent entity that can assure that the CP conforms to a set of standards.

Figure 22.6 illustrates the interactions between the actors. A CSC may request cloud services from a CSP directly or via a cloud broker. A cloud auditor conducts independent audits and may contact the others to collect necessary information. This figure shows that cloud networking issues involve three separate types of networks. For a CSP, the network architecture is that of a typical large data center, which consists of racks of high-performance servers and storage devices, interconnected with high-speed top-of-rack Ethernet switches. The concerns

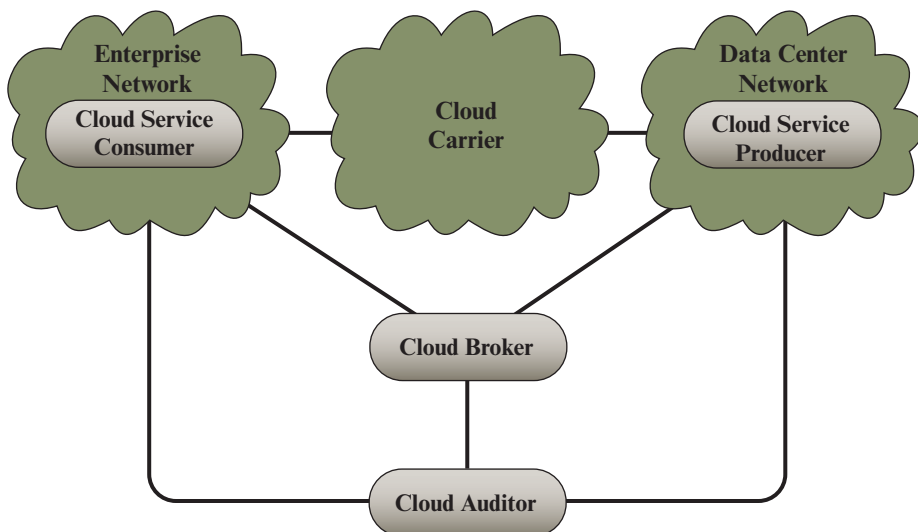

Figure 22.6 Interactions Between Actors in Cloud Computing

in this context focus on VM placement and movement, load balancing, and availability issues. The enterprise network is likely to have a quite different architecture, typically including a number of LANs, servers, workstations, PCs, and mobile devices, with a broad range of network performance, security, and management issues. The concern of both CSP and CSC with respect to the cloud carrier, which is shared with many users, is the ability to create virtual networks, with appropriate SLA and security guarantees.

22.2 CLOUD SECURITY CONCEPTS

There are numerous aspects to cloud security and numerous approaches to providing cloud security measures. A good example of the scope of cloud security concerns and issues is seen in the NIST guidelines for cloud security, specified in SP-800-144 (*Guidelines on Security and Privacy in Public Cloud Computing*, December 2011) and listed in Table 22.2. Thus, a full discussion of cloud security is well beyond the scope of this chapter.

Security is important to any computing infrastructure. Companies go to great lengths to secure on-premises computing systems, so it is not surprising that security looms as a major consideration when augmenting or replacing on-premises systems with cloud services. Allaying security concerns is frequently a prerequisite for further discussions about migrating part or all of an organization's computing architecture to the cloud. Availability is another major concern.

Generally speaking, such questions only arise when businesses contemplate moving core transaction processing, such as enterprise resource planning (ERP) systems, and other mission critical applications to the cloud. Companies have traditionally demonstrated less concern about migrating high maintenance applications such as email and payroll to cloud service providers even though such applications hold sensitive information.

Auditability is another concern for many organizations, especially those who must comply with Sarbanes-Oxley and/or Health and Human Services Health Insurance Portability and Accountability Act (HIPAA) regulations. The auditability of their data must be ensured whether it is stored on-premises or moved to the cloud.

Before moving critical infrastructure to the cloud, businesses should perform due diligence on security threats both from outside and inside the cloud. Many of the security issues associated with protecting clouds from outside threats are similar to those that have traditionally faced centralized data centers. In the cloud, however, responsibility for assuring adequate security is frequently shared among users, vendors, and any third-party firms that users rely on for security-sensitive software or configurations. Cloud users are responsible for application-level security. Cloud vendors are responsible for physical security and some software security such as enforcing external firewall policies. Security for intermediate layers of the software stack is shared between users and vendors.

A security risk that can be overlooked by companies considering a migration to the cloud is that posed by sharing vendor resources with other cloud users. Cloud providers must guard against theft or denial-of-service attacks by their users

Table 22.2 NIST Guidelines on Cloud Security and Privacy Issues and Recommendations

Governance
<p>Extend organizational practices pertaining to the policies, procedures, and standards used for application development and service provisioning in the cloud, as well as the design, implementation, testing, use, and monitoring of deployed or engaged services.</p> <p>Put in place audit mechanisms and tools to ensure organizational practices are followed throughout the system lifecycle.</p>
Compliance
<p>Understand the various types of laws and regulations that impose security and privacy obligations on the organization and potentially impact cloud computing initiatives, particularly those involving data location, privacy and security controls, records management, and electronic discovery requirements.</p> <p>Review and assess the cloud provider's offerings with respect to the organizational requirements to be met and ensure that the contract terms adequately meet the requirements.</p> <p>Ensure that the cloud provider's electronic discovery capabilities and processes do not compromise the privacy or security of data and applications.</p>
Trust
<p>Ensure that service arrangements have sufficient means to allow visibility into the security and privacy controls and processes employed by the cloud provider, and their performance over time.</p> <p>Establish clear, exclusive ownership rights over data.</p> <p>Institute a risk management program that is flexible enough to adapt to the constantly evolving and shifting risk landscape for the lifecycle of the system.</p> <p>Continuously monitor the security state of the information system to support ongoing risk management decisions.</p>
Architecture
<p>Understand the underlying technologies that the cloud provider uses to provision services, including the implications that the technical controls involved have on the security and privacy of the system, over the full system lifecycle and across all system components.</p>
Identity and access management
<p>Ensure that adequate safeguards are in place to secure authentication, authorization, and other identity and access management functions, and are suitable for the organization.</p>
Software isolation
<p>Understand virtualization and other logical isolation techniques that the cloud provider employs in its multi-tenant software architecture, and assess the risks involved for the organization.</p>
Data protection
<p>Evaluate the suitability of the cloud provider's data management solutions for the organizational data concerned and the ability to control access to data, to secure data while at rest, in transit, and in use, and to sanitize data.</p> <p>Take into consideration the risk of collating organizational data with those of other organizations whose threat profiles are high or whose data collectively represent significant concentrated value.</p> <p>Fully understand and weigh the risks involved in cryptographic key management with the facilities available in the cloud environment and the processes established by the cloud provider.</p>
Availability
<p>Understand the contract provisions and procedures for availability, data backup and recovery, and disaster recovery, and ensure that they meet the organization's continuity and contingency planning requirements.</p> <p>Ensure that during an intermediate or prolonged disruption or a serious disaster, critical operations can be immediately resumed, and that all operations can be eventually reinstated in a timely and organized manner.</p>

Incident response

Understand the contract provisions and procedures for incident response and ensure that they meet the requirements of the organization.

Ensure that the cloud provider has a transparent response process in place and sufficient mechanisms to share information during and after an incident.

Ensure that the organization can respond to incidents in a coordinated fashion with the cloud provider in accordance with their respective roles and responsibilities for the computing environment.

and users need to be protected from one another. Virtualization can be a powerful mechanism for addressing these potential risks because it protects against most attempts by users to attack one another or the provider's infrastructure. However, not all resources are virtualized and not all virtualization environments are bug-free. Incorrect virtualization may allow user code to access sensitive portions of the provider's infrastructure or the resources of other users. Once again, these security issues are not unique to the cloud and are similar to those involved in managing non-cloud data centers, where different applications need to be protected from one another.

Another security concern that businesses should consider is the extent to which subscribers are protected against the provider, especially in the area of inadvertent data loss. For example, in the event of provider infrastructure improvements, what happens to hardware that is retired or replaced? It is easy to imagine a hard disk being disposed of without being properly wiped clean of subscriber data. It is also easy to imagine permissions bugs or errors that make subscriber data visible to unauthorized users. User-level encryption may be an important self-help mechanism for subscribers, but businesses should ensure that other protections are in place to avoid inadvertent data loss.

22.3 CLOUD SECURITY RISKS AND COUNTERMEASURES

In general terms, security controls in cloud computing are similar to the security controls in any IT environment. However, because of the operational models and technologies used to enable cloud service, cloud computing may present risks that are specific to the cloud environment. The essential concept in this regard is that the enterprise loses a substantial amount of control over resources, services, and applications but must maintain accountability for security and privacy policies.

The Cloud Security Alliance [CSA17] lists the following as the 12 top cloud-specific security threats, in decreasing order of severity:

1. Data Breaches
2. Weak Identity, Credential and Access Management
3. Insecure APIs
4. System and Application Vulnerabilities
5. Account Hijacking

6. Malicious Insiders
7. Advanced Persistent Threats (APTs)
8. Data Loss
9. Insufficient Due Diligence
10. Abuse and Nefarious Use of Cloud Services
11. Denial-of-Service
12. Shared Technology Vulnerabilities

The threat analysis conducted by CSA made use of the STRIDE threat model. This section first introduces the STRIDE model and then examines each of the 12 threats.

The STRIDE Threat Model

STRIDE is a threat classification system developed by Microsoft that is a useful way of categorizing attacks that arise from deliberate actions [HERN06].

- **Spoofing identity:** An example of identity spoofing is illegally accessing and then using another user's authentication information, such as username and password. Security controls to counter such threats are in the area of **authentication**.
- **Tampering with data:** Data tampering involves the malicious modification of data. Examples include unauthorized changes made to persistent data, such as that held in a database, and the alteration of data as it flows between two computers over an open network, such as the Internet. Relevant security controls are in the area of **integrity**.
- **Repudiation:** Repudiation threats are associated with users who deny performing an action without other parties having any way to prove otherwise—for example, a user performs an illegal operation in a system that lacks the ability to trace the prohibited operations. Relevant security controls are in the area of **non-repudiation**, which refers to the ability of a system to counter repudiation threats. For example, a user who purchases an item might have to sign for the item upon receipt. The vendor can then use the signed receipt as evidence that the user did receive the package.
- **Information disclosure:** Information disclosure threats involve the exposure of information to individuals who are not supposed to have access to it—for example, the ability of users to read a file that they were not granted access to, or the ability of an intruder to read data in transit between two computers. Relevant security controls are in the area of **confidentiality**.
- **Denial-of-service:** Denial-of-service (DoS) attacks deny service to valid users—for example, by making a Web server temporarily unavailable or unusable. Relevant security controls are in the area of **availability**.
- **Elevation of privilege:** In this type of threat, an unprivileged user gains privileged access and thereby has sufficient access to compromise or destroy the entire system. Elevation of privilege threats include those situations in which

Table 22.3 Mapping Between Cloud Threats and the STRIDE Model

	S	T	R	I	D	E
Data Breaches				✓		
Weak Identity, Credential and Access Management	✓	✓	✓	✓	✓	✓
Insecure APIs		✓	✓	✓		✓
System Vulnerabilities	✓	✓	✓	✓	✓	✓
Account Hijacking	✓	✓	✓	✓	✓	✓
Malicious Insiders	✓	✓		✓		
Advanced Persistent Threats (APTs)				✓		✓
Data Loss			✓		✓	
Insufficient Due Diligence	✓	✓	✓	✓	✓	✓
Abuse and Nefarious Use of Cloud Services					✓	
Denial of Service					✓	
Shared Technology Vulnerabilities				✓		✓

S = Spoofing identity; I = Information disclosure

T = Tampering with data; D = Denial-of-service

R = Repudiation; E = Elevation of privilege.

an attacker has effectively penetrated all system defenses and become part of the trusted system itself, a dangerous situation indeed. Relevant security controls are in the area of **authorization**.

Table 22.3 provides a mapping between cloud security threats and STRIDE categories.

Data Breaches

A data breach is an incident in which sensitive, protected, or confidential information is released, viewed, stolen, or used by an individual who is not authorized to do so. There are many ways to compromise data. Deletion or alteration of records without a backup of the original content is an obvious example. Unlinking a record from a larger context may render it unrecoverable, as can storage on unreliable media. Loss of an encoding key may result in effective destruction. Finally, unauthorized parties must be prevented from gaining access to sensitive data.

The threat of data compromise increases in the cloud, due to the number of, and interactions between, risks and challenges that are either unique to the cloud or more dangerous because of the architectural or operational characteristics of the cloud environment.

Database environments used in cloud computing can vary significantly. Some providers support a multi-instance model, which provide a unique DBMS running on a VM instance for each cloud subscriber. This gives the subscriber complete control over role definition, user authorization, and other administrative tasks related to security. Other providers support a multi-tenant model, which provides a pre-defined environment for the cloud subscriber that is shared with other tenants, typically through tagging data with a subscriber identifier. Tagging gives the appearance of exclusive use of the instance, but relies on the cloud provider to establish and maintain a sound secure database environment.

Data must be secured while at rest, in transit, and in use, and access to the data must be controlled. The client can employ encryption to protect data in transit, though this involves key management responsibilities for the CSP. The client can enforce access control techniques but, again, the CSP is involved to some extent depending on the service model used.

For data at rest, the ideal security measure is for the client to encrypt the database and only store encrypted data in the cloud, with the CSP having no access to the encryption key. So long as the key remains secure, the CSP has no ability to decipher the data, although corruption and other DoS attacks remain a risk.

Weak Identity, Credential, and Access Management

Identity and access management (IAM) includes people, processes, and systems that are used to manage access to enterprise resources by assuring that the identity of an entity is verified, and then granting the correct level of access based on this assured identity. One aspect of identity management is identity provisioning, which has to do with providing access to identified users and subsequently deprovisioning, or denying access, to users when the client enterprise designates such users as no longer having access to enterprise resources in the cloud. Another aspect of identity management is for the cloud to participate in the identity management scheme used by the client enterprise. Among other requirements, the cloud service provider must be able to exchange identity attributes with the enterprise's chosen identity provider.

The access management portion of IAM involves authentication and access control services. For example, the CSP must be able to authenticate users in a trustworthy manner. The access control requirements in SPI environments include establishing trusted user profile and policy information, using it to control access within the cloud service, and doing this in an auditable way.

Insecure APIs

CSPs expose a set of software interfaces or APIs that customers use to manage and interact with cloud services. The security and availability of general cloud services are dependent upon the security of these basic APIs. From authentication and access control to encryption and activity monitoring, these interfaces

must be designed to protect against both accidental and malicious attempts to circumvent policy.

Countermeasures include (1) analyzing the security model of CSP interfaces; (2) ensuring that strong authentication and access controls are implemented in concert with encrypted transmission; and (3) understanding the dependency chain associated with the API.

System Vulnerabilities

In this context, the term *system vulnerabilities* refers to exploitable bugs or weakness in operating system and other system software on platforms that constitute the cloud infrastructure. System vulnerabilities can be exploited by hackers and malicious software across a shared cloud environment.

Countering system vulnerabilities is an ongoing technical and management process that involves risk analysis and management, regular vulnerability detection, patch management, and IT staff training. [STAL19] provides a thorough discussion of this topic.

Account Hijacking

Account or service hijacking, usually with stolen credentials, remains a top threat. With stolen credentials, attackers can often access critical areas of deployed cloud computing services, allowing them to compromise the confidentiality, integrity, and availability of those services. The concern is heightened in the context of cloud computing because:

- There is additional attack surface exposure due to increased complexity and dynamic infrastructure allocation;
- New APIs/interfaces are emerging that are untested; and
- The consumer's account, if hijacked, may be used to steal information, manipulate data, and defraud others, or to attack other tenants as an insider in the multi-tenancy environment.

Countermeasures include the following: (1) prohibit the sharing of account credentials between users and services; (2) leverage strong two-factor authentication techniques where possible; (3) employ proactive monitoring to detect unauthorized activity; and (4) understand CSP security policies and SLAs.

Malicious Insiders

Under the cloud computing paradigm, an organization relinquishes direct control over many aspects of security and, in doing so, confers an unprecedented level of trust onto the CSP. One grave concern is the risk of malicious insider activity. Cloud architectures necessitate certain roles that are extremely high risk. Examples include CSP system administrators and managed security service providers.

Countermeasures include the following: (1) enforce strict supply chain management and conduct a comprehensive supplier assessment; (2) specify human resource requirements as part of legal contract; (3) require transparency into overall information security and management practices, as well as compliance reporting; and (4) determine security breach notification processes.

Advanced Persistent Threats

An advanced persistent threat (APT) is a network attack in which an unauthorized person gains access to a network and stays there undetected for a long period of time. The intention of an APT attack is to steal data rather than to cause damage to the network or organization. APT attacks target organizations in sectors with high-value information, such as national defense, manufacturing, and the financial industry. APTs differ from other types of attack by their careful target selection, and persistent, often stealthy, intrusion efforts over extended periods.

The principle countermeasure for such threats is the effective use of threat intelligence. Threat intelligence is helping organizations understand the risks of the most common and severe external threats, such as advanced persistent threats (APTs), exploits, and zero-day threats. Although threat actors also include internal (or insider) and partner threats, the emphasis is on the types of external threats that are most likely to affect a particular organization's environment. Threat intelligence includes in-depth information about specific threats to help an organization protect itself from the types of attacks that could do them the most damage.

As an example of the importance of threat intelligence, Figure 22.7, based on one in [ISAC13] illustrates the impact of threat intelligence on an APT attack. A typical APT attack proceeds with the following steps (based on [ISAC13]):

- **Conduct background research.** An APT attack begins with research on potential targets to identify vulnerabilities.
- **Execute initial attack.** In most cases, the initial attack involves social engineering that persuades a target to take an action resulting in the download of malware. For example, the action could be clicking on a link in an email.
- **Establish foothold.** The APT inserts an initial malware package onto the target system. This initial package is designed to elude antimalware software. There may be minimal functionality in this first package. However, it is able to connect back to the attack source to download more capable malware.
- **Enable persistence.** Once a foothold is established, the APT seeks to make its presence more permanent. The two objectives are to maintain its presence through a device reboot and maintain a sustained ability to communicate between the threat source and the target device.

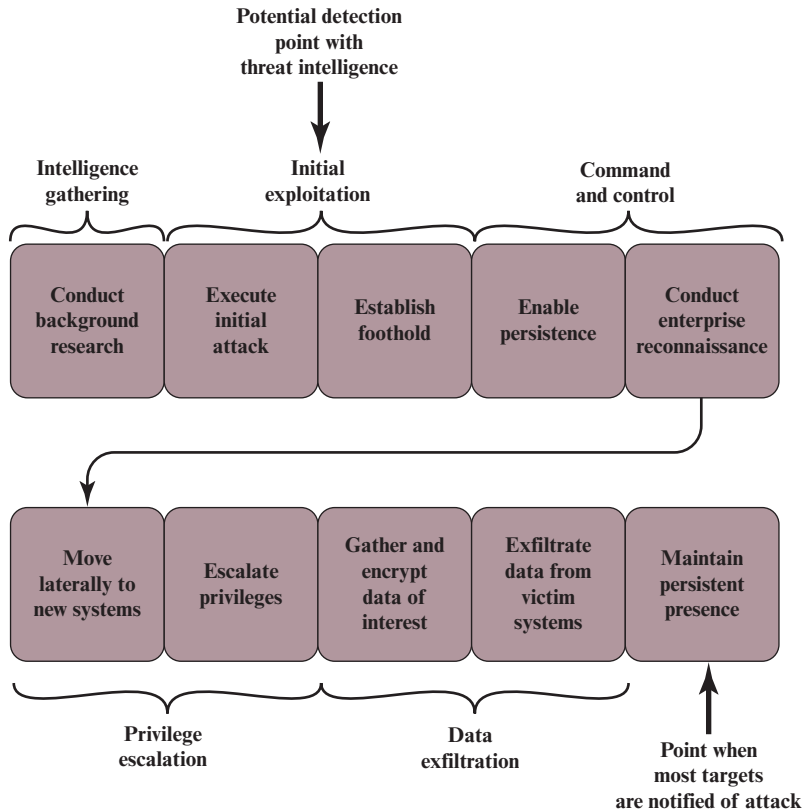

Figure 22.7 Threat Intelligence for Countering Advanced Persistent Threats

- **Conduct enterprise reconnaissance.** The APT can now attempt to find the servers or storage facilities holding the targeted information. This can often be done using utility software on the compromised device. Alternatively, the APT installs its own scanning tools.
- **Move laterally to new systems.** Once established in the target system, the APT will attempt to compromise other systems in the target environment by installing additional malware on these systems.
- **Escalate privileges.** The APT software on the target systems will look for ways to increase the privilege level of the software, enabling the software to access more resources on infected systems and to more easily gain privileged access to other systems.
- **Gather and encrypt data of interest.** The APT typically creates a compressed, encrypted file of any targeted data to which it gains access. This tactic thwarts anti-malware software that looks for specific patterns in data or in packet transmissions.

- **Exfiltrate data from victim systems.** The APT may use a variety of tools and protocols to surreptitiously transfer data from the target systems.
- **Maintain persistent presence.** The APT remains on the system for an extended period of time. There may be dormant periods, followed by activation from remote control software.

As Figure 22.7 indicates, threat intelligence may enable a security team to become aware of a threat well before the point of typical notification, which is often after the real damage is done. Even if an early opportunity is lost, threat intelligence can cut down the time it takes to discover that an attack has already succeeded and therefore speed up remediation actions to limit the damage.

Data Loss

Data loss refers to the permanent loss of CSC data that are stored in the cloud through accidental or malicious deletion of data and backup copies from cloud storage.

To counter this threat, the CSC should be assured that the CSP has a thorough redundancy scheme with regular backups, including geographic redundancy. This may be supplemented by a cloud-to-premise backup so that a recent copy is available at the customer site.

Insufficient Due Diligence

This category refers to the due diligence that should be performed by a CSC before choosing a particular CSP. At a general level, the enterprise needs to analyze the risks involved in moving to a cloud-based solution. Beyond that, the choice of CSP and the contractual terms with that CSP must be scrutinized carefully to minimize risk.

[TIER15] lists the following general categories of due diligence:

- **Verify infrastructure:** The CSPs infrastructure consists of facilities, hardware, system and application software, core connectivity, and external network interfaces. The CSP should rely on standardized, enterprise-class equipment, and software with documented integration schemes.
- **Verify certification:** At minimum, the CSP should demonstrate that it is in compliance with all relevant security and privacy laws and regulations. In addition, the CSP should follow industry best practices as documented in numerous NIST documents, specifications from the Cloud Security Alliance, and various industry and standards organization specifications.
- **Verify the CSP's due diligence:** The CSP must document and, as appropriate, demonstrate that it is doing its own due diligence to ensure that its equipment, networks, and protocols actually work through a broad spectrum of scenarios, both ordinary and catastrophic.
- **Verify data protection:** The CSP should be able to document a comprehensive and integrated set of security controls to ensure against data breaches and data loss.

Abuse and Nefarious Use of Cloud Services

For many CSPs, it is relatively easy for a CSC to register and begin using cloud services, some even offering free limited trial periods. This enables attackers to get inside the cloud to conduct various attacks, such as spamming, malicious code attacks, and DoS. PaaS providers have traditionally suffered most from this kind of attacks; however, recent evidence shows that hackers have begun to target IaaS vendors as well. The burden is on the CSP to protect against such attacks, but CSCs must monitor activity with respect to their data and resources to detect any malicious behavior.

Countermeasures include (1) stricter initial registration and validation processes; (2) enhanced credit card fraud monitoring and coordination; (3) comprehensive introspection of customer network traffic; and (4) monitoring public blacklists for one's own network blocks.

Denial-of-Service

By the nature of the service it provides, a public CSP has to be exposed to the Internet and other public networks, its presence advertised, and its interfaces well-defined. These factors make CSPs a logical target for DoS attacks. Such attacks can prevent, for a time, a CSC from accessing their data or their applications.

The countermeasure for such attacks is for the CSP (1) to perform ongoing threat intelligence to be aware of the nature of potential attacks and the potential vulnerabilities in their cloud and (2) to deploy automated tools to spot and defend the core cloud services from such attacks.

Shared Technology Vulnerabilities

IaaS vendors deliver their services in a scalable way by sharing infrastructure. Often, the underlying components that make up this infrastructure (CPU caches, GPUs, etc.) were not designed to offer strong isolation properties for a multi-tenant architecture. CSPs typically approach this risk by the use of isolated virtual machines for individual clients. This approach is still vulnerable to attack, by both insiders and outsiders, and so can only be a part of an overall security strategy.

Countermeasures include the following: (1) implement security best practices for installation/configuration; (2) monitor environment for unauthorized changes/activity; (3) promote strong authentication and access control for administrative access and operations; (4) enforce SLAs for patching and vulnerability remediation; and (5) conduct vulnerability scanning and configuration audits.

22.4 CLOUD SECURITY AS A SERVICE

The term security as a service has generally meant a package of security services offered by a service provider that offloads much of the security responsibility from an enterprise to the security service provider. Among the services typically provided are authentication, antivirus, antimalware/spyware, intrusion detection, and security event management. In the context of cloud computing, cloud security as a service, designated SecaaS, is a segment of the SaaS offering of a CSP.

The Cloud Security Alliance defines SecaaS as the provision of security applications and services via the cloud either to cloud-based infrastructure and software or from the cloud to the customers' on-premise systems [CSA11]. The Cloud Security Alliance has identified the following SecaaS categories of service:

- Identity and access management
- Data loss prevention
- Web security
- Email security
- Security assessments
- Intrusion management
- Security information and event management
- Encryption
- Business continuity and disaster recovery
- Network security

In this section, we examine these categories with a focus on security of the cloud-based infrastructure and services (Figure 22.8).

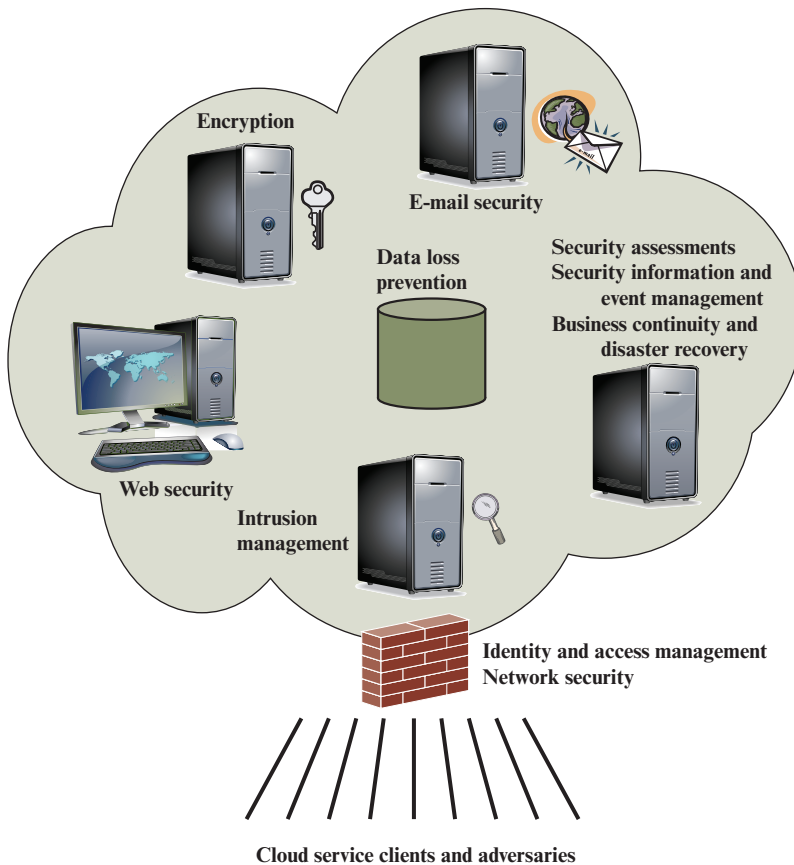

Figure 22.8 Elements of Cloud Security as a Service

Identity and access management (IAM) is defined in Section 22.3.

Data loss prevention (DLP) is the monitoring, protecting, and verifying the security of data at rest, in motion, and in use. Much of DLP can be implemented by the cloud client, such as discussed in Section 13.3. The CSP can also provide DLP services, such as implementing rules about what functions can be performed on data in various contexts.

Web security is real-time protection offered either on premise through software/appliance installation or via the Cloud by proxying or redirecting Web traffic to the CSP. This provides an added layer of protection on top of things like anti-viruses to prevent malware from entering the enterprise via activities such as Web browsing. In addition to protecting against malware, a cloud-based Web security service might include usage policy enforcement, data backup, traffic control, and Web access control.

A CSP may provide a Web-based email service, for which security measures are needed. **Email security** provides control over inbound and outbound email, protecting the organization from phishing, malicious attachments, enforcing corporate policies such as acceptable use and spam prevention. The CSP may also incorporate digital signatures on all email clients and provide optional email encryption.

Security assessments are third-party audits of cloud services. While this service is outside the province of the CSP, the CSP can provide tools and access points to facilitate various assessment activities.

Intrusion management encompasses intrusion detection, prevention, and response. The core of this service is the implementation of intrusion detection systems (IDSs) and intrusion prevention systems (IPSs) at entry points to the cloud and on servers in the cloud. An IDS is a set of automated tools designed to detect unauthorized access to a host system. An IPS incorporates IDS functionality but also includes mechanisms designed to block traffic from intruders.

Security information and event management (SIEM) aggregates (via push or pull mechanisms) log and event data from virtual and real networks, applications, and systems. This information is then correlated and analyzed to provide real-time reporting and alerting on information/events that may require intervention or other type of response. The CSP typically provides an integrated service that can put together information from a variety of sources both within the cloud and within the client enterprise network.

Encryption is a pervasive service that can be provided for data at rest in the cloud, email traffic, client-specific network management information, and identity information. Encryption services provided by the CSP involve a range of complex issues, including key management, how to implement VPN services in the cloud, application encryption, and data content access.

Business continuity and disaster recovery comprise measures and mechanisms to ensure operational resiliency in the event of any service interruptions. This is an area where the CSP, because of economies of scale, can offer obvious benefits to a cloud service client. The CSP can provide backup at multiple locations, with reliable failover and disaster recovery facilities. This service must include a flexible infrastructure, redundancy of functions and hardware, monitored operations, geographically distributed data centers, and network survivability.

Network security consists of security services that allocate access, distribute, monitor, and protect the underlying resource services. Services include perimeter and server firewalls and DoS protection. Many of the other services listed in this section, including intrusion management, identity and access management, data loss protection, and Web security, also contribute to the network security service.

22.5 AN OPEN-SOURCE CLOUD SECURITY MODULE

This section provides an overview of an open-source security module that is part of the OpenStack cloud OS. OpenStack is an open source software project of the OpenStack Foundation that aims to produce an open source cloud operating system [ROSA14, SEFR12]. The principal objective is the enable creating and managing huge groups of virtual private servers in a cloud computing environment. OpenStack is embedded, to one degree or another, into data center infrastructure and cloud computing products offered by Cisco, IBM, Hewlett-Packard, and other vendors. It provides multi-tenant IaaS, and aims to meet the needs of public and private clouds regardless of size, by being simple to implement and massively scalable.

The OpenStack OS consists of a number of independent modules, each of which has a project name and a functional name. The modular structure is easy to scale out and provides a commonly used set of core services. Typically the components are configured together to provide a comprehensive IaaS capability. However, the modular design is such that the components are generally capable of being used independently.

The security module for OpenStack is Keystone. Keystone provides the shared security services essential for a functioning cloud computing infrastructure. It provides the following main services:

- **Identity:** This is user information authentication. This information defines a user's role and permissions within a project, and is the basis for a role-based access control (RBAC) mechanism. Keystone supports multiple methods of authentication, including user name and password, Lightweight Directory Access Protocol (LDAP), and a means of configuring external authentication methods supplied by the CSC.
- **Token:** After authentication, a token is assigned and used for access control. OpenStack services retain tokens and use them to query Keystone during operations.
- **Service catalog:** OpenStack service endpoints are registered with Keystone to create a service catalog. A client for a service connects to Keystone, and determines an endpoint to call based on the returned catalog.
- **Policies:** This service enforces different user access levels. Each OpenStack service defines the access policies for its resources in an associated policy file. A resource, for example, could be API access, the ability to attach to a volume, or to fire up instances. These policies can be modified or updated by the cloud administrator to control the access to the various resources.

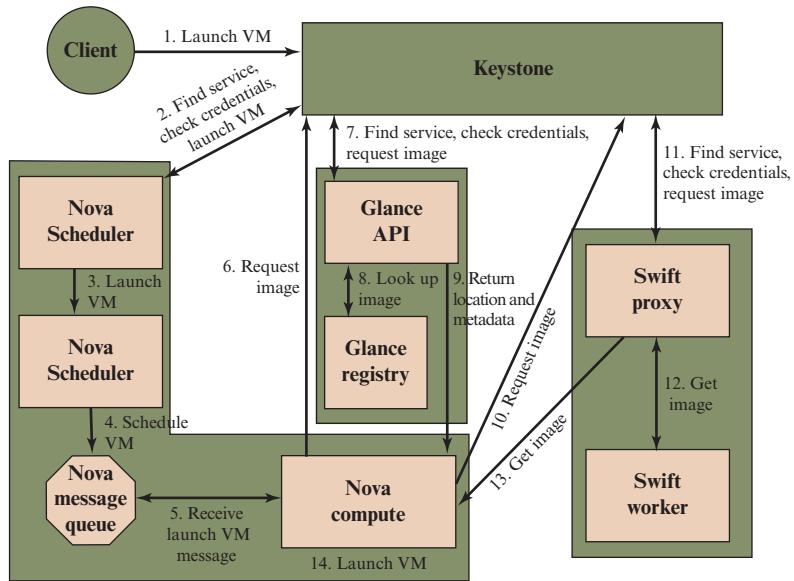

Figure 22.9 Launching a Virtual Machine in OpenStack

Figure 22.9 illustrates the way in which Keystone interacts with other OpenStack components to launch a new VM. Nova is the management software module that controls VMs within the IaaS cloud computing platform. It manages the lifecycle of compute instances in an OpenStack environment. Responsibilities include spawning, scheduling, and decommissioning of machines on demand. Thus, Nova enables enterprises and service providers to offer on-demand computing resources, by provisioning and managing large networks of VMs. Glance is a lookup and retrieval system for VM disk images. It provides services for discovering, registering, and retrieving virtual images through an API. Swift is a distributed object store that creates a redundant and scalable storage space of up to multiple petabytes of data. Object storage does not present a traditional file system, but rather a distributed storage system for static data such as VM images, photo storage, email storage, backups, and archives.

22.6 KEY TERMS AND REVIEW QUESTIONS

Key Terms

cloud auditor cloud broker cloud carrier	cloud service consumer (CSC) cloud service provider (CSP)	private cloud public cloud
--	--	-------------------------------

Review Questions

- 22.1 What are the essential characteristics of cloud computing?
- 22.2 List and briefly define the deployment models of cloud computing.
- 22.3 What is the cloud computing reference architecture?
- 22.4 Describe some of the main cloud-specific security threats.
- 22.5 What is OpenStack?

CHAPTER 23

INTERNET OF THINGS (IoT) SECURITY

23.1 The Internet of Things

- Things on the Internet of Things
- Evolution
- Components of IoT-Enabled Things
- IoT and Cloud Context

23.2 IoT Security Concepts and Objectives

- Unique Characteristics of the IoT Ecosystem
- IoT Security Objectives
- Tamper Resistance and Detection
- Gateway Security
- The IoT Security Environment

23.3 An Open-Source IoT Security Module

- Cryptographic Algorithms
- Operating Modes
- Offset Codebook Mode

23.4 Key Terms and Review Questions

LEARNING OBJECTIVES

After studying this chapter, you should be able to:

- ◆ Explain the scope of the Internet of Things.
- ◆ List and discuss the five principal components of IoT-enabled things.
- ◆ Understand the relationship between cloud computing and IoT.
- ◆ Define the patching vulnerability.
- ◆ Explain the IoT Security Framework.
- ◆ Understand the MiniSec security feature for wireless sensor networks.

This chapter begins with an overview of the concepts of the IoT, followed by a discussion of IoT security.

23.1 THE INTERNET OF THINGS

The Internet of Things is the latest development in the long and continuing revolution of computing and communications. Its size, ubiquity, and influence on everyday lives, business, and government dwarf any technical advance that has gone before. This section provides a brief overview of the Internet of Things.

Things on the Internet of Things

The **Internet of Things (IoT)** is a term that refers to the expanding interconnection of smart devices, ranging from appliances to tiny sensors. A dominant theme is the embedding of short-range mobile transceivers into a wide array of gadgets and everyday items, enabling new forms of communication between people and things, and between things themselves. The Internet now supports the interconnection of billions of industrial and personal objects, usually through cloud systems. The objects deliver sensor information, act on their environment, and in some cases modify themselves, to create overall management of a larger system, like a factory or city.

The IoT is primarily driven by deeply embedded devices. These devices are low-bandwidth, low-repetition data capture and low-bandwidth data-usage appliances that communicate with each other and provide data via user interfaces. Embedded appliances, such as high-resolution video security cameras, video VoIP phones, and a handful of others, require high-bandwidth streaming capabilities. Yet countless products simply require packets of data to be intermittently delivered.

Evolution

With reference to the end systems supported, the Internet has gone through roughly four generations of deployment culminating in the IoT:

1. **Information technology (IT):** PCs, servers, routers, firewalls, and so on, bought as IT devices by enterprise IT people, primarily using wired connectivity.
2. **Operational technology (OT):** Machines/appliances with embedded IT built by non-IT companies, such as medical machinery, SCADA (supervisory control and data acquisition), process control, and kiosks, bought as appliances by enterprise OT people and primarily using wired connectivity.
3. **Personal technology:** Smartphones, tablets, and eBook readers bought as IT devices by consumers (employees) exclusively using wireless connectivity and often multiple forms of wireless connectivity.
4. **Sensor/actuator technology:** Single-purpose devices bought by consumers, IT, and OT people exclusively using wireless connectivity, generally of a single form, as part of larger systems.

It is the fourth generation that is usually thought of as the IoT, and which is marked by the use of billions of embedded devices.

Components of IoT-Enabled Things

The key components of an IoT-enabled device are the following (Figure 23.1):

- **Sensor:** A sensor measures some parameter of a physical, chemical, or biological entity and delivers an electronic signal proportional to the observed characteristic, either in the form of an analog voltage level or a digital signal.

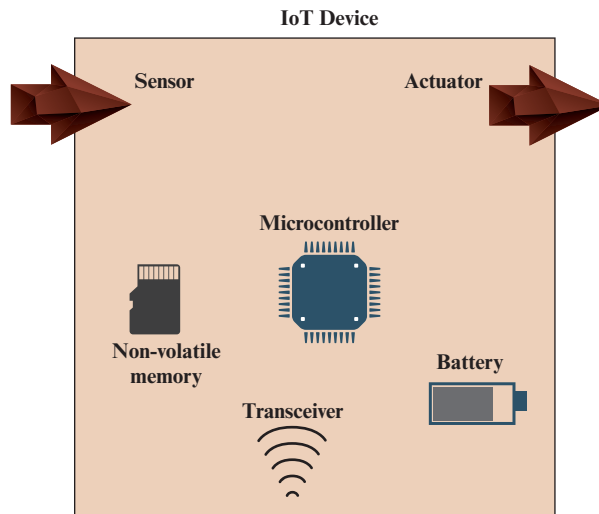

Figure 23.1 IoT Components

In both cases, the sensor output is typically input to a microcontroller or other management element.

- **Actuator:** An actuator receives an electronic signal from a controller and responds by interacting with its environment to produce an effect on some parameter of a physical, chemical, or biological entity.
- **Microcontroller:** The “smart” in a smart device is provided by a deeply embedded microcontroller.
- **Transceiver:** A transceiver contains the electronics needed to transmit and receive data. Most IoT devices contain a wireless transceiver, capable of communication using Wi-Fi, ZigBee, or some other wireless scheme.
- **Power supply:** Typically, this is a battery.

IoT devices also often contain a Radio-Frequency Identification (RFID) component. RFID technology, which uses radio waves to identify items, is increasingly becoming an enabling technology for IoT. The main elements of an RFID system are tags and readers. RFID tags are small programmable devices used for object, animal, and human tracking. They come in a variety of shapes, sizes, functionalities, and costs. RFID readers acquire and sometimes rewrite information stored on RFID tags that come within operating range (a few inches up to several feet). Readers are usually connected to a computer system that records and formats the acquired information for further uses.

IoT and Cloud Context

To better understand the function of an IoT, it is useful to view it in the context of a complete enterprise network that includes third-party networking and cloud computing elements. Figure 23.2 provides an overview illustration.

EDGE At the **edge** of a typical enterprise network is a network of IoT-enabled devices, consisting of sensors and perhaps actuators. These devices may communicate with one another. For example, a cluster of sensors may all transmit their data to one sensor that aggregates the data to be collected by a higher-level entity. At this level also there may also be a number of gateways. A gateway interconnects the IoT-enabled devices with the higher-level communication networks. It performs the necessary translation between the protocols used in the communication networks and those used by devices. It may also perform a basic data aggregation function.

FOG In many IoT deployments, massive amounts of data may be generated by a distributed network of sensors. For example, offshore oil fields and refineries can generate a terabyte of data per day. An airplane can create multiple terabytes of data per hour. Rather than store all of that data permanently (or at least for a long period) in central storage accessible to IoT applications, it is often desirable to do as much data processing close to the sensors as possible. Thus, the purpose of what is sometimes referred to as the fog computing level is to convert network data flows into information that is suitable for storage and higher level processing. Processing elements at this level may deal with high volumes of data and perform

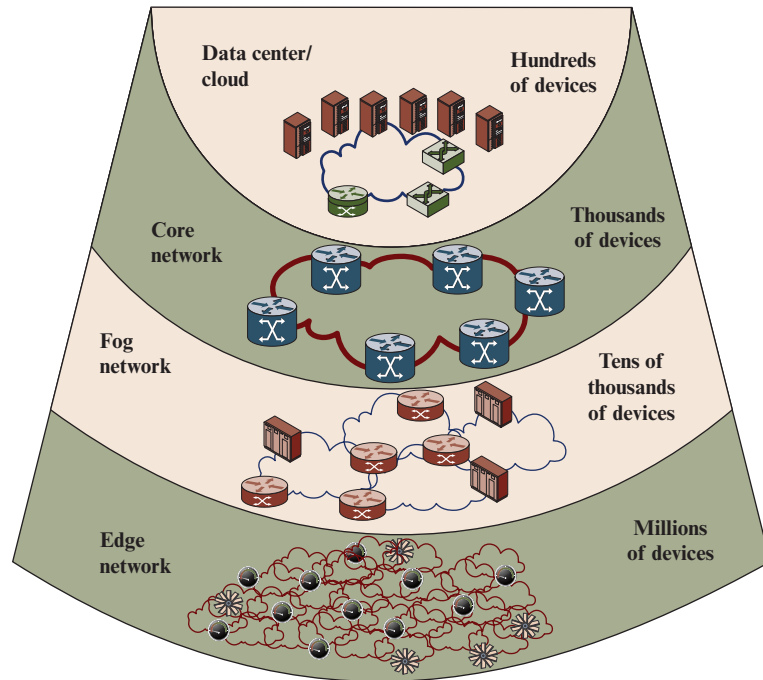

Figure 23.2 The IoT/Cloud Context

data transformation operations, resulting in the storage of much lower volumes of data. The following are examples of **fog** computing operations:

- **Evaluation:** Evaluating data for criteria as to whether it should be processed at a higher level.
- **Formatting:** Reformatting data for consistent higher-level processing.
- **Expanding/decoding:** Handling cryptic data with additional context (such as the origin).
- **Distillation/reduction:** Reducing and/or summarizing data to minimize the impact of data and traffic on the network and higher-level processing systems.
- **Assessment:** Determining whether data represent a threshold or alert; this could include redirecting data to additional destinations.

Generally, fog computing devices are deployed physically near the edge of the IoT network; that is, near the sensors and other data-generating devices. Thus, some of the basic processing of large volumes of generated data is offloaded and outsourced from IoT application software located at the center.

Fog computing and fog services are expected to be a distinguishing characteristic of the IoT. Fog computing represents an opposite trend in modern networking from cloud computing. With cloud computing, massive, centralized storage and processing resources are made available to distributed customers over cloud networking

facilities to a relatively small number of users. With fog computing, massive numbers of individual smart objects are interconnected with fog networking facilities that provide processing and storage resources close to the edge devices in an IoT. Fog computing addresses the challenges raised by the activity of thousands or millions of smart devices, including security, privacy, network capacity constraints, and latency requirements. The term *fog computing* is inspired by the fact that fog tends to hover low to the ground whereas clouds are high in the sky.

CORE The **core** network, also referred to as a **backbone network**, connects geographically dispersed fog networks as well as provides access to other networks that are not part of the enterprise network. Typically, the core network will use very high performance routers, high-capacity transmission lines, and multiple interconnected routers for increased redundancy and capacity. The core network may also connect to high-performance, high-capacity servers, such as large database servers and private cloud facilities. Some of the core routers may be purely internal, providing redundancy and additional capacity without serving as edge routers.

CLOUD The **cloud** network provides storage and processing capabilities for the massive amounts of aggregated data that originate in IoT-enabled devices at the edge. Cloud servers also host the applications that interact with and manage the IoT devices and that analyze the IoT-generated data.

Table 23.1 compares cloud and fog computing.

Table 23.1 Comparison of Cloud and Fog Features

	Cloud	Fog
Location of processing/storage resources	Center	Edge
Latency	High	Low
Access	Fixed or wireless	Mainly wireless
Support for mobility	Not applicable	Yes
Control	Centralized/hierarchical (full control)	Distributed/hierarchical (partial control)
Service access	Through core	At the edge/on handheld device
Availability	99.99%	Highly volatile/highly redundant
Number of users/devices	Tens/hundreds of millions	Tens of billions
Main content generator	Human	Devices/sensors
Content generation	Central location	Anywhere
Content consumption	End device	Anywhere
Software virtual infrastructure	Central enterprise servers	User devices

23.2 IOT SECURITY CONCEPTS AND OBJECTIVES

IoT is perhaps the most complex and undeveloped area of network security. To see this, consider Figure 23.3, which shows the main elements of interest for IoT security. At the center of the network are the application platforms, data storage servers, and network and security management systems. These central systems gather data from sensors, send control signals to actuators, and are responsible for managing the IoT devices and their communication networks. At the edge of the network are IoT-enabled devices, some of which are quite simple, constrained devices and some of which are more intelligent, unconstrained devices. In addition, gateways may perform protocol conversion and other networking service on behalf of IoT devices.

Figure 23.3 illustrates a number of typical scenarios for interconnection and the inclusion of security features. The shading in Figure 23.3 indicates the systems that support at least some of these functions. Typically, gateways will implement secure functions, such as TLS and IPsec. Unconstrained devices may or may not implement some security capability. Constrained devices generally have limited or no security features. As suggested in the figure, gateway devices can provide secure communication between the gateway and the devices at the center, such as application platforms and management platforms. However, any constrained or unconstrained devices attached to the gateway are outside the zone of security established between the gateway and the central systems. As shown, unconstrained devices can communicate directly with the center and support security functions. However, constrained devices that are not connected to gateways have no secure communications with central devices.

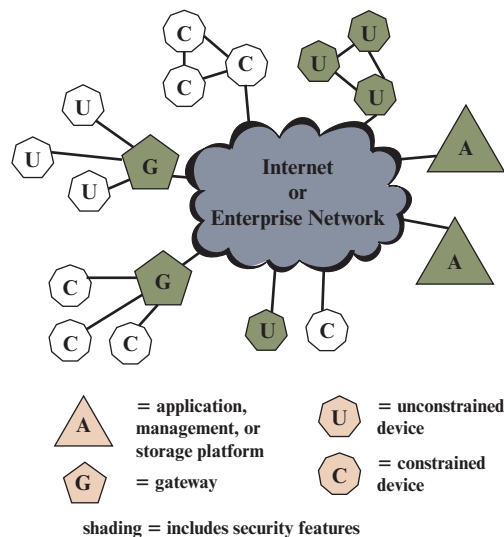

Figure 23.3 IoT Security: Elements of Interest

Unique Characteristics of the IoT Ecosystem

The European Union Agency For Network And Information Security (ENISA) *Baseline Security Recommendations for IoT* [ENIS17] lists the following issues that hinder the development of secure IoT ecosystems:

- **Very large attack surfaces:** This topic is explored later in this section. In essence, there are a wide variety of points of vulnerability within an IoT ecosystem and a large variety of data that may be compromised.
- **Limited device resources:** IoT devices are typically constrained devices, with limited memory, processing power, and power supply.
This makes it difficult to employ advanced security controls.
- **Complex ecosystem:** The IoT involves not only a large number of devices, but the interconnections, communications, and dependencies among them and with cloud elements. This makes the task of assessing security risk extremely complex.
- **Fragmentation of standards and regulations:** Comparatively little work has been done on security standards for IoT, as well as limited best practices documentation. Thus, there is a lack of comprehensive guidance for security managers and implementers.
- **Widespread deployment:** There is an ongoing rapid deployment of IoT arrangements in commercial environments and, more importantly, critical infrastructure environments. These deployments are attractive targets for security attacks and the rapid deployment is often without comprehensive risk assessment and security planning.
- **Security integration:** IoT devices use a wide variety of communications protocols, and when implemented, authentication schemes. In addition, there may be contractor viewpoints and requirements from all involved stakeholders. Integrating security into an interoperable scheme is thus extraordinarily challenging.
- **Safety aspects:** Because many IoT devices act on their physical environment, security threats can become safety threats, raising the bar for the effectiveness of security solutions.
- **Low cost:** IoT devices are manufactured, purchased, and deployed in millions. This provides great incentive for all parties to minimize the cost of these devices. Manufacturers might be inclined to limit security features to maintain a low cost, and customers might be inclined to accept these limitations.
- **Lack of expertise:** IoT is still a relatively new and rapidly evolving technology. There are a limited number of people with suitable cybersecurity training and experience.
- **Security updates:** In an often-quoted 2014 article, security expert Bruce Schneier stated that we are at a crisis point with regard to the security of embedded systems, including IoT devices [SCHN14]. The embedded devices are riddled with vulnerabilities and there is no good way to patch them. The chip manufacturers have strong incentives to produce their product with its

firmware and software as quickly and cheaply as possible. The device manufacturers choose a chip based on price and features and do very little if anything to the chip software and firmware. Their focus is the functionality of the device itself. The end user may have no means of patching the system or, if so, little information about when and how to patch. The result is that the hundreds of millions of Internet-connected devices in the IoT are vulnerable to attack. This is certainly a problem with sensors, allowing attackers to insert false data into the network. It is potentially a graver threat with actuators, where the attacker can affect the operation of machinery and other devices.

- **Insecure programming:** Effective cybersecurity practice requires the integration of security planning and design throughout the software development lifecycle. But again, with cost pressure, developers of IoT products have an incentive to place more emphasis on functionality and usability than on security.
- **Unclear liabilities:** A major IoT deployment involves a large and complex supply chain and complex interaction among numerous components. Because it is difficult under these circumstances to clearly assign liabilities, ambiguities and conflicts may arise in the event of a security incident.

IoT Security Objectives

NISTIR 8200 (*Interagency Report on Status of International Cybersecurity Standardization for the Internet of Things*) lists the following security objectives for IoT:

- **Restricting logical access to the IoT network.** This may include: using unidirectional gateways, using firewalls to prevent network traffic from passing directly between the corporate and IoT networks, and having separate authentication mechanisms and credentials for users of the corporate and IoT networks. An IoT system should also use a network topology that has multiple layers, with the most critical communications occurring in the most secure and reliable layer.
- **Restricting physical access to IoT network and components.** A combination of physical access controls should be used, such as locks, card readers, and/or guards.
- **Protecting individual IoT components from exploitation.** This includes deploying security patches in as expeditious a manner as possible, after testing them under field conditions; disabling all unused ports and services and assuring that they remain disabled; restricting IoT user privileges to only those that are required for each person's role; tracking and monitoring audit trails; and using security controls such as antivirus software and file integrity checking software where technically feasible.
- **Preventing unauthorized modification of data.** This includes data that are in transit (at least across the network boundaries) and at rest.
- **Detecting security events and incidents.** The object is to detect security events early enough to break the attack chain before attackers attain their objectives. This includes the capability to detect failed IoT components, unavailable services, and exhausted resources that are important to provide proper and safe functioning of an IoT system.

- **Maintaining functionality during adverse conditions.** This involves designing IoT systems so that each critical component has a redundant counterpart. Additionally, if a component fails, it should fail in a manner that does not generate unnecessary traffic on IoT or other networks, or does not cause another problem elsewhere. IoT systems should also allow for graceful degradation such as moving from normal operation with full automation to emergency operation with operators more involved and less automation to manual operation with no automation.
- **Restoring the system after an incident.** Incidents are inevitable and an incident response plan is essential. A major characteristic of a good security program is how quickly the IoT system can be recovered after an incident has occurred.

Tamper Resistance and Detection

An IoT ecosystem involves a large number of devices deployed in the edge network and in the fog network. Typically these involve numerous manufacturers and multiple supply chains and often deployment in areas where physical security is difficult. Two essential security measures in such an environment are tamper resistance and tamper detection. We define the following terms:

- **Tampering:** An unauthorized modification that alters the intended functioning of a system or device in a way that degrades the security it provides.
- **Tamper resistant:** A characteristic of a system component that provides passive protection against an attack.
- **Tamper detection:** Techniques to ensure that the overall system is made aware of unwanted physical access.

TAMPER RESISTANCE The common approach to tamper resistance is to use specialized physical construction materials to make tampering with a fog node difficult. Examples include hardened steel enclosures, locks, and security screws. Tightly packing components and circuit boards within an enclosure increases the difficulty of using fiber optics to probe inside the node without opening the enclosure.

A second category of tamper resistance is the deterrence of tampering by ensuring that tampering leaves visible evidence behind. Examples include special seals and tapes that make it obvious when there has been physical tampering.

TAMPER DETECTION Mechanisms for tamper detection include the following:

- **Switches:** A variety of switches, such as mercury switches, magnetic switches, and pressure contacts can detect the opening of a device, the breach of a physical security boundary, or the movement of a device.
- **Sensors:** Temperature and radiation sensors can detect environmental changes. Voltage and power sensors can detect electrical attacks.
- **Circuitry:** It is possible to wrap components with flexible circuitry, resistance wire, or fiber optics so as to detect a puncture or break.

Gateway Security

ITU-T Recommendation Y.2066 (Common Requirements of the Internet of Things, June 2014) includes a list of security requirements for the IoT. This list is a useful baseline for understand the scope of security implementation needed for an IoT deployment. The requirements are defined as being the functional requirements during capturing, storing, transferring, aggregating and processing the data of things, as well as to the provision of services which involve things. These requirements are related to all the IoT actors. The requirements are:

- **Communication security:** Secure, trusted, and privacy-protected communication capability is required, so that unauthorized access to the content of data can be prohibited, integrity of data can be guaranteed, and privacy-related content of data can be protected during data transmission or transfer in IoT.
- **Data management security:** Secure, trusted, and privacy-protected data management capability is required, so that unauthorized access to the content of data can be prohibited, integrity of data can be guaranteed, and privacy-related content of data can be protected when storing or processing data in IoT.
- **Service provision security:** Secure, trusted, and privacy-protected service provision capability is required, so that unauthorized access to service and fraudulent service provision can be prohibited and privacy information related to IoT users can be protected.
- **Integration of security policies and techniques:** The ability to integrate different security policies and techniques is required, so as to ensure a consistent security control over the variety of devices and user networks in IoT.
- **Mutual authentication and authorization:** Before a device (or an IoT user) can access the IoT, mutual authentication and authorization between the device (or the IoT user) and IoT is required to be performed according to predefined security policies.
- **Security audit:** Security audit is required to be supported in IoT. Any data access or attempt to access IoT applications are required to be fully transparent, traceable, and reproducible according to appropriate regulation and laws. In particular, IoT is required to support security audit for data transmission, storage, processing, and application access.

A key element in providing security in an IoT deployment is the gateway. Y.2067 (*Common Requirements and Capabilities of a Gateway for Internet of Things Applications*, June 2014) details specific security functions that the gateway should implement, some of which are illustrated in Figure 23.4. These consist of the following:

- Support identification of each access to the connected devices.
- Support authentication with devices. Based on application requirements and device capabilities, it is required to support mutual or one-way authentication with devices. With one-way authentication, either the device authenticates itself to the gateway or the gateway authenticates itself to the device, but not both.
- Support mutual authentication with applications.

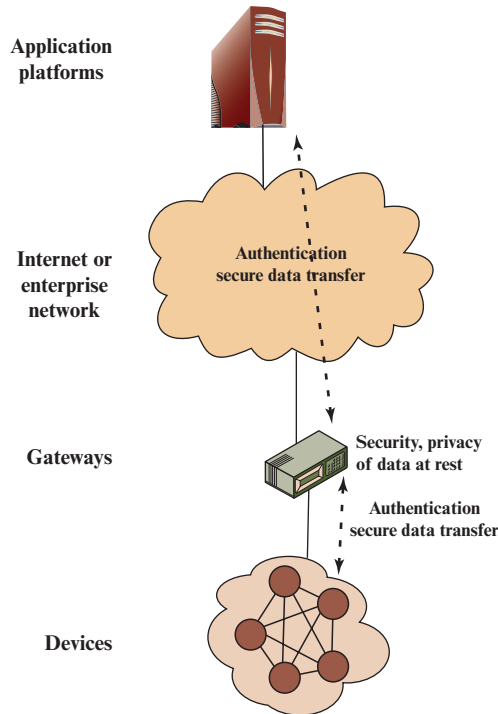

Figure 23.4 IoT Gateway Security Functions

- Support the security of the data that are stored in devices and the gateway, or transferred between the gateway and devices, or transferred between the gateway and applications. Support the security of these data based on security levels.
- Support mechanisms to protect privacy for devices and the gateway.
- Support self-diagnosis and self-repair as well as remote maintenance.
- Support firmware and software update.
- Support auto configuration or configuration by applications. The gateway is required to support multiple configuration modes, e.g., remote and local configuration, automatic and manual configuration, and dynamic configuration based on policies.

Some of these requirements may be difficult to achieve when they involve providing security services for constrained devices. For example, the gateway should support security of data stored in devices. Without encryption capability at the constrained device, this may be impractical to achieve.

Note that the Y.2067 requirements make a number of references to privacy requirements. Privacy is an area of growing concern with the widespread deployment of IoT-enabled things in homes, retail outlets, and vehicles and humans. As more things are interconnected, governments and private enterprises will collect massive amounts of data about individuals, including medical information, location and movement information, and application usage.

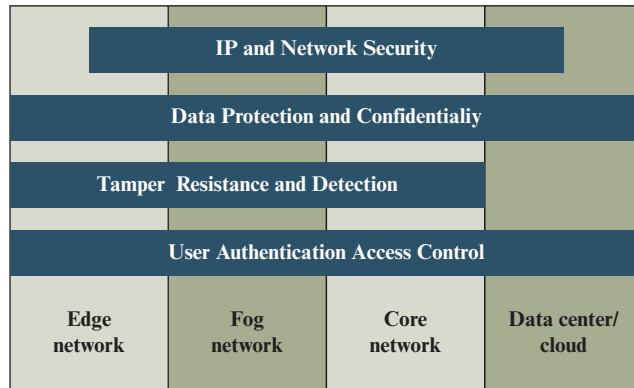

Figure 23.5 IoT Security Environment

The IoT Security Environment

Figure 23.5 models the scope of key security capabilities across the four levels of the IoT ecosystem:

- **User authentication and access control:** These functions span the entire IoT ecosystem. A common approach to access control is role-based access control (RBAC). RBAC systems assign access rights to roles instead of individual users. In turn, users are assigned to different roles, either statically or dynamically, according to their responsibilities. RBAC enjoys widespread commercial use in cloud and enterprise systems and is a well-understood tool that can be used to manage access to IoT devices and the data they generate.
- **Tamper resistance and detection:** This function is particularly important at the device and fog network levels but also extends to the core network level. All of these levels may involve components that are physically outside the area of the enterprise that is protected by physical security measures.
- **Data protection and confidentiality:** These functions extend to all levels of the architecture.
- **Internet protocol and network security:** Protection of data in motion from eavesdropping and snooping is essential between all levels.

23.3 AN OPEN-SOURCE IOT SECURITY MODULE

This section provides an overview of MiniSec, an open-source security module that is part of the TinyOS operating system. TinyOS is designed for small embedded systems with tight requirements on memory, processing time, real-time response, and power consumption. TinyOS takes the process of streamlining quite far, resulting in a very minimal OS for embedded systems, with a typical configuration requiring 48 KB of code and 10 KB of RAM [LEVI12]. The main application of TinyOS is wireless sensor networks and it has become the de facto OS for such networks. With sensor networks, the primary security concerns relate to wireless

communications. MiniSec is designed to be a link-level module that offers a high level of security, while simultaneously keeping energy consumption low and using very little memory [LUK07]. MiniSec provides confidentiality, authentication, and replay protection.

MiniSec has two operating modes, one tailored for single-source communication, and another tailored for multi-source broadcast communication. The latter does not require per-sender state for replay protection and thus scales to large networks.

MiniSec is designed to meet the following requirements:

- **Data authentication:** Enables a legitimate node to verify whether a message originated from another legitimate node (i.e., a node with which it shares a secret key) and was unchanged during transmission.
- **Confidentiality:** A basic requirement for any secure communications system.
- **Replay protection:** Prevents an attacker from successfully recording a packet and replaying it at a later time.
- **Freshness:** Because sensor nodes often stream time-varying measurements, providing guarantee of message freshness is an important property. There are two types of freshness: strong freshness and weak freshness. MiniSec provides a mechanism to guarantee weak freshness, where a receiver can determine a partial ordering over received messages without a local reference time point.
- **Low energy overhead:** This is achieved by minimizing communication overhead and by the use of only symmetric.
- **Resilient to lost messages:** The relatively high occurrence of dropped packets in wireless sensor networks requires a design that can tolerate high message loss rates.

Cryptographic Algorithms

Two cryptographic algorithms used by MiniSec are worth noting. The first of these is the encryption algorithm Skipjack. Skipjack was developed in the 1990s by the U.S. National Security Agency (NSA). It is one of the simplest and fastest block cipher algorithms, which is critical to embedded systems. A study of eight possible candidate algorithms for wireless security networks [LAW06] concluded that Skipjack was the best algorithm in terms of code memory, data memory, encryption/decryption efficiency, and key setup efficiency.

Skipjack makes use of an 80-bit key. It was intended by NSA to provide a secure system once it became clear that DES, with only a 56-bit key, was vulnerable. Contemporary algorithms, such as AES, employ a key length of at least 128 bits, and 80 bits is generally considered inadequate. However, for the limited application of wireless sensor networks and other IoT devices, which provide large volumes of short data blocks over a slow data link, Skipjack may suffice. With its efficient computation and low memory footprint, Skipjack is an attractive choice for IoT devices. However, going forward, it is advisable for any IoT security module to use one of the recently developed lightweight cryptographic algorithms, such as the Scalable Encryption Algorithm (SEA) described in Chapter 14.

The block cipher mode of operation chosen for MiniSec is the Offset Codebook Mode (OCB), described later in this section.

MiniSec employs per-device keys; that is, each key is unique to a particular pair of devices, to prevent replay attacks.

Operating Modes

MiniSec has two operating modes: unicast (MiniSec-U) and broadcast (MiniSec-B). Both schemes use OCB with a counter, known as a nonce, that is input along with the plaintext into the encryption algorithm. The least significant bits of the counter are also sent as plaintext to enable synchronization. For both modes, data are transmitted in packets. Each packet includes the encrypted data block, the OCB authentication tag, and the MiniSec counter.

MiniSec-U employs synchronized counters, which require the receiver to keep a local counter for each sender. The strictly monotonically increasing counter guarantees semantic confidentiality.¹ Even if the sender *A* repeatedly sends the same message, each ciphertext is different since a different counter value is used. Also, once a receiver observes a counter value, it rejects packets with an equal or smaller counter value. Therefore, an attacker cannot replay any packet that the receiver has previously received. If a number of packets are dropped, the sender and receiver engage in a resynchronization protocol.

MiniSec-U cannot be directly used to secure broadcast communication. First, it would be too expensive to run the counter resynchronization protocol among many receivers. Also, if a node were to simultaneously receive packets from a large group of sending nodes, it would need to maintain a counter for each sender, resulting in high memory overhead. Instead, it uses two mechanisms, a timing-based approach and a bloom-filter approach, that defend against replay attacks. First, the time is divided into *t*-length epochs *E*₁, *E*₂, . . . Using the current epoch or the previous epoch as nonce for OCB encryption, the replay of messages from older epochs is avoided. The timing approach is augmented with a bloom-filter approach in order to prevent replay attacks inside the current epoch. MiniSec-B uses as nonce element in OCB encryption and bloom-filter key the string *nodeID.E_i.C_{ab}*, where *nodeID* is the sender node identifier, *E_i* is the current epoch, and *C_{ab}* is a shared counter. Every time that a node receives a message, it checks if it belongs to its bloom filter. If the message is not replayed, it is stored in the bloom filter. Else, the node drops it.

For further details on the two operating modes, see [TOBA07].

Offset Codebook Mode

As mentioned in Chapter 7, a mode of operation must be specified when a plaintext source consists of multiple blocks of data to be encrypted with the same encryption key. OCB is an NIST proposed block cipher mode of operation [ROGA01], and is a proposed Internet Standard defined in RFC 7253 (*The OCB Authenticated-Encryption Algorithm*, May 2014). OCB is also approved as an authenticated encryption technique in the IEEE 802.11 wireless LAN standard. And, OCB is included in MiniSec, an open-source IoT security module.

¹Semantic confidentiality means that if the same plain-text is encrypted twice, the two resulting ciphertexts are different.

A key objective for OCB is efficiency. This is achieved by minimizing the number of encryptions required per message and by allowing for parallel operation on the blocks of a message. OCB mode is provably secure assuming the underlying block cipher is secure. OCB mode is a one-pass mode of operation making it highly efficient. Only one block cipher call is necessary for each plaintext block, with an additional two calls needed to complete the whole encryption process. OCB is especially well suited for the stringent energy constraints of sensor nodes.

Figure 23.6 shows the overall structure for OCB encryption and authentication. Typically, AES is used as the encryption algorithm. The message M to be encrypted and authenticated is divided into n -bit blocks, with the exception of the last block, which may be less than n bits. Typically, $n = 128$. Only a single pass through the message is required to generate both the ciphertext and the authentication code. The total number of blocks is $m = \lceil \text{len}(M) / n \rceil$.

Note that the encryption structure for OCB is similar to that of electronic codebook (ECB) mode. Each block is encrypted independently of the other blocks, so that it is possible to perform all m encryptions simultaneously. As was mentioned in Chapter 7, with ECB, if the same b -bit block of plaintext appears more than once

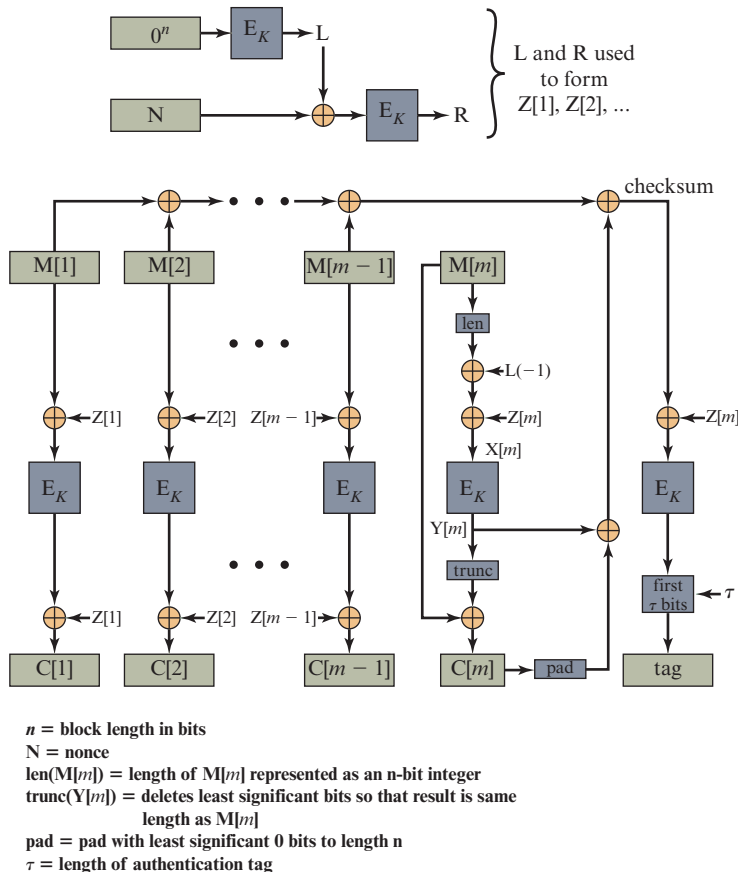

Figure 23.6 OCB Encryption and Authentication

in the message, it always produces the same ciphertext. Because of this, for lengthy messages, the ECB mode may not be secure. OCB eliminates this property by using an offset $Z[i]$ for each block $M[i]$, such that each $Z[i]$ is unique; the offset is XORed with the plaintext and XORed again with the encrypted output. Thus, with encryption key K we have

$$C[i] = E_K(M[i] \oplus Z[i]) \oplus Z[i]$$

where $E_K(X)$ is the encryption of plaintext X using key K , and \oplus is the exclusive-OR operation. Because of the use of the offset, two blocks in the same message that are identical will produce two different ciphertexts.

The upper part of Figure 23.6 indicates how the $Z[i]$ are generated. An arbitrary n -bit value N called the nonce is chosen; the only requirement is that if multiple messages are encrypted with the same key, a different nonce must be used each time such that each nonce is only used once. Each different value of N will produce a different set of $Z[i]$. Thus, if two different messages have identical blocks in the same position in the message, they will produce different ciphertexts because the $Z[i]$ will be different.

The calculation of the $Z[i]$ is somewhat complex and is summarized in the following equations:

$$\begin{aligned} L(0) &= L = E_K(0^n) && \text{where } 0^n \text{ is consists of } n \text{ zero bits.} \\ R &= E_K(N \oplus L) \\ L(i) &= 2 \cdot L(i-1) && 1 \leq i \leq m \\ Z[1] &= L \oplus R \\ Z[i] &= Z(i-1) \oplus L(\text{ntz}(i)) && 1 \leq i \leq m \end{aligned}$$

The operator \cdot refers to multiplication over the finite field $GF(2^n)$. The operator $\text{ntz}(i)$ denotes the number of trailing (least significant) zeros in i . The resulting $Z[i]$ values are a maximal Hamming distance apart [WALK05].

Thus, the values $Z[i]$ are a function of both the nonce and the encryption key. The nonce does not need to be kept secret and is communicated to the recipient in a manner outside the scope of the specification.

Because the length of M may not be an integer multiple of n , the final block is treated differently, as shown in Figure 23.6. The length of $M[m]$, represented as an n -bit integer, is used to calculate $X[m] = \text{len}(M[m]) \oplus L(-1) \oplus Z[m]$. $L(-1)$ is defined as $L/2$ over the finite field or, equivalently, $L \cdot 2^{-1}$. Next, $Y[m] = E_K(X[m])$. Then, $Y[m]$ is truncated to $\text{len}(M[m])$ bits (by deleting the necessary number of least significant bits) and XORed with $M[m]$. Thus, the final ciphertext C is the same length as the original plaintext M .

A checksum is produced from the message M as follows:

$$\text{checksum} = M[1] \oplus M[2] \oplus \dots \oplus Y[m] \oplus C[m]0^*$$

where $C[m]0^*$ consists of $C[m]$ padded with least significant bits to the length n . Finally, an authentication tag of length τ is generated, using the same key as is used for encryption:

$$\text{tag} = \text{first } \tau \text{ bits of } E_K(\text{checksum} \oplus Z[m])$$

<p>algorithm OCB-Encrypt_K(N, M)</p> <p>Partition M into M[1]...M[m]</p> <p>$L \leftarrow L(0) \leftarrow E_K(0^\tau)$</p> <p>$R \leftarrow E_K(N \oplus L)$</p> <p>for $i \leftarrow 1$ to m do $L(i) \leftarrow 2 \cdot L(i-1)$</p> <p>$L(-1) = L \cdot 2^{-1}$</p> <p>$Z[1] \leftarrow L \oplus R$</p> <p>for $i \leftarrow 2$ to m do $Z[i] \leftarrow Z[i-1] \oplus L(\text{ntz}(i))$</p> <p>for $i \leftarrow 1$ to $m-1$ do</p> <p style="padding-left: 20px;">$C[i] \leftarrow E_K(M[i] \oplus Z[i]) \oplus Z[i]$</p> <p>$X[m] \leftarrow \text{len}(M[m]) \oplus L(-1) \oplus Z[m]$</p> <p>$Y[m] \leftarrow E_K(X[m])$</p> <p>$C[m] \leftarrow M[m] \oplus (\text{first } \text{len}(M[m]) \text{ bits of } Y[m])$</p> <p>Checksum \leftarrow</p> <p style="padding-left: 20px;">$M[1] \oplus \dots \oplus M[m-1] \oplus C[m]0^* \oplus Y[m]$</p> <p>Tag $\leftarrow E_K(\text{Checksum} \oplus Z[m])$ [first τ bits]</p>	<p>algorithm OCB-Decrypt_K(N, M)</p> <p>Partition M into M[1]...M[m]</p> <p>$L \leftarrow L(0) \leftarrow E_K(0^\tau)$</p> <p>$R \leftarrow E_K(N \oplus L)$</p> <p>for $i \leftarrow 1$ to m do $L(i) \leftarrow 2 \cdot L(i-1)$</p> <p>$L(-1) = L \cdot 2^{-1}$</p> <p>$Z[1] \leftarrow L \oplus R$</p> <p>for $i \leftarrow 2$ to m do $Z[i] \leftarrow Z[i-1] \oplus L(\text{ntz}(i))$</p> <p>for $i \leftarrow 1$ to $m-1$ do</p> <p style="padding-left: 20px;">$M[i] \leftarrow D_K(C[i] \oplus Z[i]) \oplus Z[i]$</p> <p>$X[m] \leftarrow \text{len}(M[m]) \oplus L(-1) \oplus Z[m]$</p> <p>$Y[m] \leftarrow E_K(X[m])$</p> <p>$M[m] \leftarrow (\text{first } \text{len}(C[m]) \text{ bits of } Y[m]) \oplus C[m]$</p> <p>Checksum \leftarrow</p> <p style="padding-left: 20px;">$M[1] \oplus \dots \oplus M[m-1] \oplus C[m]0^* \oplus Y[m]$</p> <p>Tag' $\leftarrow E_K(\text{Checksum} \oplus Z[m])$ [first τ bits]</p>
---	--

Figure 23.7 OCB Algorithms

The bit length τ of the tag varies according to the application. The size of the tag controls the level of authentication. To verify the authentication tag, the decryptor can recompute the checksum, then recompute the tag, and finally check that is equal to the one that was sent. If the ciphertext passes the test, then OCB produces the plaintext normally.

Figure 23.7 summarizes the OCB algorithms for encryption and decryption. It is easy to see that decryption is the inverse of encryption. We have

$$\begin{aligned}
 E_K(M[i] \oplus Z[i]) \oplus Z[i] &= C[i] \\
 E_K(M[i] \oplus Z[i]) &= C[i] \oplus Z[i] \\
 D_K(E_K(M[i] \oplus Z[i])) &= D_K(C[i] \oplus Z[i]) \\
 M[i] \oplus Z[i] &= D_K(C[i] \oplus Z[i]) \\
 M[i] &= D_K(C[i] \oplus Z[i]) \oplus Z[i]
 \end{aligned}$$

23.4 KEY TERMS AND REVIEW QUESTIONS

Key Terms

actuator	edge	microcontroller
backbone network	fog	operational technology (OT)
cloud	information technology (IT)	sensor
core	Internet of Things (IoT)	transceiver

Review Questions

- 23.1** Define the Internet of Things (IoT).
- 23.2** List and briefly define the principal components of an IoT-enabled thing.
- 23.3** Define the patching vulnerability.
- 23.4** Define tamper resistance and tamper detection.
- 23.5** What is MiniSec?

APPENDIX A

BASIC CONCEPTS FROM LINEAR ALGEBRA

A.1 Operations on Vectors and Matrices

Arithmetic
Determinants
Inverse of a Matrix

A.2 Linear Algebra Operations over Z_n

A.1 OPERATIONS ON VECTORS AND MATRICES

We use the following conventions:

$$(x_1 \quad x_2 \quad \cdots \quad x_m) \begin{pmatrix} y_1 \\ y_2 \\ \vdots \\ y_n \end{pmatrix} \begin{pmatrix} a_{11} & a_{12} & \cdots & a_{1n} \\ a_{21} & a_{22} & \cdots & a_{2n} \\ \vdots & \vdots & \ddots & \vdots \\ a_{m1} & a_{m2} & \cdots & a_{mn} \end{pmatrix}$$

row vector **X** column vector **Y** matrix **A**

Note that in a matrix, the first subscript of an element refers to the row and the second subscript refers to the column.

Arithmetic

Two matrices of the same dimensions can be added or subtracted element by element. Thus, for $\mathbf{C} = \mathbf{A} + \mathbf{B}$, the elements of \mathbf{C} are $c_{ij} = a_{ij} + b_{ij}$.

$$\text{Example: } \begin{pmatrix} 1 & -2 & 3 \\ 0 & 4 & 5 \\ 3 & 6 & 9 \end{pmatrix} + \begin{pmatrix} 3 & 0 & -6 \\ 2 & -3 & 1 \\ 9 & 6 & 3 \end{pmatrix} = \begin{pmatrix} 4 & -2 & -3 \\ 2 & 1 & 6 \\ 12 & 12 & 12 \end{pmatrix}$$

To multiply a matrix by a scalar, every element of the matrix is multiplied by the scalar. Thus, for $\mathbf{C} = k\mathbf{A}$, we have $c_{ij} = k \times a_{ij}$.

$$\text{Example: } 3 \begin{pmatrix} 1 & -2 & 3 \\ 0 & 4 & 5 \\ 3 & 6 & 9 \end{pmatrix} = \begin{pmatrix} 3 & -6 & 9 \\ 0 & 12 & 15 \\ 9 & 18 & 27 \end{pmatrix}$$

The product of a row vector of dimension m and a column vector of dimension m is a scalar:

$$(x_1 \quad x_2 \quad \cdots \quad x_m) \times \begin{pmatrix} y_1 \\ y_2 \\ \vdots \\ y_m \end{pmatrix} = x_1y_1 + x_2y_2 + \cdots + x_my_m$$

Two matrices \mathbf{A} and \mathbf{B} are conformable for multiplication, in that order, if the number of columns in \mathbf{A} is the same as the number of rows in \mathbf{B} . Let \mathbf{A} be of order $m \times n$ (m rows and n columns) and \mathbf{B} be of order $n \times p$. The product is obtained by multiplying every row of \mathbf{A} into every column of \mathbf{B} , using the rules just defined for the product of a row vector and a column vector. Thus, for $\mathbf{C} = \mathbf{AB}$, we have

$c_{ij} = \sum_{k=1}^n a_{ik}b_{kj}$, and the resulting matrix is of order $m \times p$. Notice that, by these rules, we can multiply a row vector by a matrix that has the same number of rows as the

dimension of the vector; and we can multiply a matrix by a column vector if the matrix has the same number of columns as the dimension of the vector. Thus, using the notation at the beginning of this section: For $\mathbf{D} = \mathbf{XA}$, we end up with a row vector with elements $d_i = \sum_{k=1}^m x_k a_{ki}$. For $\mathbf{E} = \mathbf{AY}$, we end up with a column vector with elements $e_i = \sum_{k=1}^m a_{ik} y_k$.

Example:

$$\begin{aligned} (2 \quad -5 \quad 3) \begin{pmatrix} 1 & -2 & 3 \\ 0 & 4 & 5 \\ 3 & 6 & 9 \end{pmatrix} &= (2+3 \times 3 \quad 2 \times (-2) + (-5) \times 4 + 3 \times 6 \\ &\quad 2 \times 3 + (-5) \times 5 + 3 \times 9) \\ &= (11 \quad -6 \quad 8) \end{aligned}$$

$$\text{Example: } \begin{pmatrix} 1 & -2 & 3 \\ 0 & 4 & 5 \\ 3 & 6 & 9 \end{pmatrix} \begin{pmatrix} 2 \\ -5 \\ 3 \end{pmatrix} = \begin{pmatrix} 1 \times 2 + (-2) \times (-5) + 3 \times 3 \\ 4 \times (-5) + 5 \times 3 \\ 3 \times 2 + 6 \times (-5) + 9 \times 3 \end{pmatrix} = \begin{pmatrix} 21 \\ -5 \\ 3 \end{pmatrix}$$

Determinants

The determinant of the square matrix \mathbf{A} , denoted by $\det(\mathbf{A})$, is a scalar value representing sums and products of the elements of the matrix. For details, see any text on linear algebra. Here, we simply report the results.

For a 2×2 matrix \mathbf{A} , $\det(\mathbf{A}) = a_{11}a_{22} - a_{21}a_{12}$.

For a 3×3 matrix \mathbf{A} , $\det(\mathbf{A}) = a_{11}a_{22}a_{33} + a_{12}a_{23}a_{31} + a_{13}a_{21}a_{32} - a_{31}a_{22}a_{13} - a_{32}a_{23}a_{11} - a_{33}a_{21}a_{12}$

In general, the determinant of a square matrix can be calculated in terms of its cofactors. A **cofactor** of \mathbf{A} is denoted by $\text{cof}_{ij}(\mathbf{A})$ and is defined as the determinant of the reduced matrix formed by deleting the i th row and j th column of \mathbf{A} and choosing positive sign if $i + j$ is even and the negative sign if $i + j$ is odd. For example:

$$\text{cof}_{23} \begin{pmatrix} 2 & 4 & 3 \\ 6 & 1 & 5 \\ -2 & 1 & 3 \end{pmatrix} = -\det \begin{pmatrix} 2 & 4 \\ -2 & 1 \end{pmatrix} = -10$$

The determinant of an arbitrary $n \times n$ square matrix can be evaluated as:

$$\begin{aligned} \det(\mathbf{A}) &= \sum_{j=1}^n [a_{ij} \text{cof}_{ij}(\mathbf{A})] \quad \text{for any } i \\ &\quad \text{or} \\ \det(\mathbf{A}) &= \sum_{i=1}^n [a_{ij} \text{cof}_{ij}(\mathbf{A})] \quad \text{for any } j \end{aligned}$$

For example:

$$\begin{aligned} \det \begin{pmatrix} 2 & 4 & 3 \\ 6 & 1 & 5 \\ -2 & 1 & 3 \end{pmatrix} &= a_{21}\text{cof}_{21} + a_{22}\text{cof}_{22} + a_{23}\text{cof}_{23} \\ &= 6 \times \left(-\det \begin{pmatrix} 4 & 3 \\ 1 & 3 \end{pmatrix} \right) + 1 \times \det \begin{pmatrix} 2 & 3 \\ -2 & 3 \end{pmatrix} + 5 \times \left(-\det \begin{pmatrix} 2 & 4 \\ -2 & 1 \end{pmatrix} \right) \\ &= 6(-9) + 1(12) + 5(-10) = -92 \end{aligned}$$

Inverse of a Matrix

If a matrix \mathbf{A} has a nonzero determinant, then it has an inverse, denoted as \mathbf{A}^{-1} . The inverse has that property that $\mathbf{A}\mathbf{A}^{-1} = \mathbf{A}^{-1}\mathbf{A} = \mathbf{I}$, where \mathbf{I} is the matrix that is all zeros except for ones along the main diagonal from upper left to lower right. \mathbf{I} is known as the identity matrix because any vector or matrix multiplied by \mathbf{I} results in the original vector or matrix. The inverse of a matrix is calculated as follows. For $\mathbf{B} = \mathbf{A}^{-1}$,

$$b_{ij} = \frac{\text{cof}_{ji}(\mathbf{A})}{\det(\mathbf{A})}$$

For example, if \mathbf{A} is the matrix in the preceding example, then for the inverse matrix \mathbf{B} , we can calculate:

$$b_{32} = \frac{\text{cof}_{23}(\mathbf{A})}{\det(\mathbf{A})} = \frac{-10}{-92} = \frac{10}{92}$$

Continuing in the fashion, we can compute all nine elements of \mathbf{B} . Using Sage, we can easily calculate the inverse:

```
sage: A = Matrix([[2, 4, 3], [6, 1, 5], [-2, 1, 3]])
sage: A
```

```
[ 2 4 3]
[ 6 1 5]
[-2 1 3]
sage: A^-1
```

```
[ 1/46  9/92 -17/92]
[ 7/23 -3/23 -2/23]
[-2/23  5/46  11/46]
```

And we have:

$$\begin{pmatrix} 2 & 4 & 3 \\ 6 & 1 & 5 \\ -2 & 1 & 3 \end{pmatrix} \begin{pmatrix} 2/92 & 9/92 & -17/92 \\ 28/92 & -12/92 & -8/92 \\ -8/92 & 10/92 & 22/92 \end{pmatrix} = \begin{pmatrix} 2/92 & 9/92 & -17/92 \\ 28/92 & -12/92 & -8/92 \\ -8/92 & 10/92 & 22/92 \end{pmatrix} \begin{pmatrix} 2 & 4 & 3 \\ 6 & 1 & 5 \\ -2 & 1 & 3 \end{pmatrix} \\ = \begin{pmatrix} 1 & 0 & 0 \\ 0 & 1 & 0 \\ 0 & 0 & 1 \end{pmatrix}$$

A.2 LINEAR ALGEBRA OPERATIONS OVER Z_n

Arithmetic operations on vectors and matrices can be carried out over Z_n ; that is, all operations can be carried out modulo n . The only restriction is that division is only allowed if the divisor has a multiplicative inverse in Z_n . For our purposes, we are interested primarily in operations over Z_{26} . Because 26 is not a prime, not every integer in Z_{26} has a multiplicative inverse. Table A.1 lists all the multiplicative inverses modulo 26. For example $3 \times 9 = 1 \pmod{26}$, so 3 and 9 are multiplicative inverses of each other.

Table A.1 Multiplicative Inverses mod 26

Value	Inverse
1	1
3	9
5	21
7	15
9	3
11	19

Value	Inverse
15	7
17	23
19	11
21	5
23	17

As an example, consider the following matrix in Z_{26} . $\mathbf{A} = \begin{pmatrix} 4 & 3 \\ 9 & 6 \end{pmatrix}$. Then,

$$\det(\mathbf{A}) = (4 \times 6) - (3 \times 9) \pmod{26} = -3 \pmod{26} = 23$$

From Table A.1, we have $(\det(\mathbf{A}))^{-1} = 17$. We can now calculate the inverse matrix:

$$\mathbf{A}^{-1} = (\det(\mathbf{A}))^{-1} \begin{pmatrix} \text{cof}_{11}(\mathbf{A}) & \text{cof}_{21}(\mathbf{A}) \\ \text{cof}_{12}(\mathbf{A}) & \text{cof}_{22}(\mathbf{A}) \end{pmatrix} = 17 \times \begin{pmatrix} 6 & -3 \\ -9 & 4 \end{pmatrix} \pmod{26} = \begin{pmatrix} 24 & 1 \\ 3 & 16 \end{pmatrix}$$

To verify:

$$\mathbf{A}\mathbf{A}^{-1} = \begin{pmatrix} 4 & 3 \\ 9 & 6 \end{pmatrix} \begin{pmatrix} 24 & 1 \\ 3 & 16 \end{pmatrix} \pmod{26} = \begin{pmatrix} 105 & 52 \\ 234 & 105 \end{pmatrix} \pmod{26} = \begin{pmatrix} 1 & 0 \\ 0 & 1 \end{pmatrix}$$

$$\mathbf{A}^{-1}\mathbf{A} = \begin{pmatrix} 24 & 1 \\ 3 & 16 \end{pmatrix} \begin{pmatrix} 4 & 3 \\ 9 & 6 \end{pmatrix} \bmod 26 = \begin{pmatrix} 105 & 78 \\ 156 & 105 \end{pmatrix} \bmod 26 = \begin{pmatrix} 1 & 0 \\ 0 & 1 \end{pmatrix}$$

We now work out the details of the example of the Hill cipher from Section 3.2. First we encrypt the plaintext (15 0 24) using the encryption key

$$\mathbf{K} = \begin{pmatrix} 17 & 17 & 5 \\ 21 & 18 & 21 \\ 2 & 2 & 19 \end{pmatrix}$$

The encryption equation is $\mathbf{C} = \mathbf{PK} \bmod 26$. Therefore,

$$\begin{aligned} \mathbf{C} &= (15 \ 0 \ 24) \begin{pmatrix} 17 & 17 & 5 \\ 21 & 18 & 21 \\ 2 & 2 & 19 \end{pmatrix} \bmod 26 \\ &= ((15 \times 17 + 0 \times 21 + 24 \times 2) \quad (15 \times 17 + 0 \times 18 + 24 \times 2) \\ &\quad (15 \times 5 + 0 \times 21 + 24 \times 19)) \bmod 26 \\ &= (303 \ 303 \ 531) \bmod 26 \\ &= (17 \ 17 \ 11) \end{aligned}$$

For decryption, we use the equation $\mathbf{P} = \mathbf{CK}^{-1} \bmod 26$. First, we compute the inverse of the matrix \mathbf{K} . From the earlier definition of determinants, we have:

$$\det(\mathbf{K}) = k_{11}k_{22}k_{33} + k_{12}k_{23}k_{31} + k_{13}k_{21}k_{32} - k_{31}k_{22}k_{13} - k_{32}k_{23}k_{11} - k_{33}k_{21}k_{12} \bmod 26$$

$$\det(\mathbf{K}) = (17 \times 18 \times 19) + (17 \times 21 \times 2) + (5 \times 21 \times 2)(2 \times 18 \times 5) - (2 \times 21 \times 17) - (19 \times 21 \times 17) \bmod 26$$

$$\det(\mathbf{K}) = 5814 + 714 + 210 - 180 - 714 - 6783 \bmod 26$$

$$\det(\mathbf{K}) = -939 \bmod 26 = (-37 \times 26) + 23 \bmod 26 = 23$$

From Table A.1, $(\det(\mathbf{K}))^{-1} = 17$. We can now calculate the inverse matrix. For convenience, we label the inverse of \mathbf{K} as $\mathbf{B} = \mathbf{K}^{-1}$. Using the results from Section E.1, the matrix elements of \mathbf{B} are as follows:

$$b_{ij} = \frac{\text{cof}_{ji}(\mathbf{K})}{\det(\mathbf{K})} \bmod 26 = 17 \times \text{cof}_{ji}(\mathbf{K}) \bmod 26$$

For the matrix of this example, we have:

$$\begin{aligned} b_{11} &= \begin{vmatrix} 18 & 21 \\ 2 & 19 \end{vmatrix} \times 17 \bmod 26 = (18 \times 19 - 21 \times 2) \times 17 \bmod 26 \\ &= 5100 \bmod 26 = 4 \end{aligned}$$

$$\begin{aligned} b_{12} &= - \begin{vmatrix} 17 & 5 \\ 2 & 19 \end{vmatrix} \times 17 \bmod 26 = -(17 \times 19 - 5 \times 2) \times 17 \bmod 26 \\ &= -5321 \bmod 26 = 9 \end{aligned}$$

$$\begin{aligned} b_{13} &= \begin{vmatrix} 17 & 5 \\ 18 & 21 \end{vmatrix} \times 17 \bmod 26 = (17 \times 21 - 5 \times 18) \times 17 \bmod 26 \\ &= 4539 \bmod 26 = 15 \end{aligned}$$

$$\begin{aligned} b_{21} &= -\begin{vmatrix} 21 & 21 \\ 2 & 19 \end{vmatrix} \times 17 \bmod 26 = -(21 \times 19 - 21 \times 2) \times 17 \bmod 26 \\ &= -6069 \bmod 26 = 15 \end{aligned}$$

$$\begin{aligned} b_{22} &= \begin{vmatrix} 17 & 5 \\ 2 & 19 \end{vmatrix} \times 17 \bmod 26 = (17 \times 19 - 5 \times 2) \times 17 \bmod 26 \\ &= 5321 \bmod 26 = 17 \end{aligned}$$

$$\begin{aligned} b_{23} &= -\begin{vmatrix} 17 & 5 \\ 21 & 21 \end{vmatrix} \times 17 \bmod 26 = -(17 \times 21 - 5 \times 21) \times 17 \bmod 26 \\ &= -4284 \bmod 26 = 6 \end{aligned}$$

$$\begin{aligned} b_{31} &= \begin{vmatrix} 21 & 18 \\ 2 & 2 \end{vmatrix} \times 17 \bmod 26 = (21 \times 2 - 18 \times 2) \times 17 \bmod 26 \\ &= 102 \bmod 26 = 24 \end{aligned}$$

$$\begin{aligned} b_{32} &= -\begin{vmatrix} 17 & 17 \\ 2 & 2 \end{vmatrix} \times 17 \bmod 26 = -(17 \times 2 - 17 \times 2) \times 17 \bmod 26 \\ &= 0 \bmod 26 = 0 \end{aligned}$$

$$\begin{aligned} b_{33} &= \begin{vmatrix} 17 & 17 \\ 21 & 18 \end{vmatrix} \times 17 \bmod 26 = (17 \times 18 - 17 \times 21) \times 17 \bmod 26 \\ &= -867 \bmod 26 = 17 \end{aligned}$$

This yields an inverse matrix of

$$\mathbf{K}^{-1} = \begin{pmatrix} 4 & 9 & 15 \\ 15 & 17 & 6 \\ 24 & 0 & 17 \end{pmatrix}$$

The decryption equation is $\mathbf{P} = \mathbf{CK}^{-1} \bmod 26$. Therefore,

$$\begin{aligned} \mathbf{P} &= (17 \quad 17 \quad 11) \begin{pmatrix} 4 & 9 & 15 \\ 15 & 17 & 6 \\ 24 & 0 & 17 \end{pmatrix} \bmod 26 \\ &= ((17 \times 4 + 17 \times 15 + 11 \times 24) \quad (17 \times 9 + 17 \times 17 + 11 \times 0) \\ &\quad (17 \times 15 + 17 \times 6 + 11 \times 17)) \bmod 26 \\ &= (587 \quad 442 \quad 544) \bmod 26 \\ &= (15 \quad 0 \quad 4) \end{aligned}$$

which is the original plaintext.

APPENDIX B

MEASURES OF SECRECY AND SECURITY

B.1 Conditional Probability

B.2 Perfect Secrecy

B.3 Information and Entropy

Information

Entropy

Properties of the Entropy Function

Conditional Entropy

B.4 Entropy and Secrecy

B.5 Min-Entropy

In this appendix, we look at measures of secrecy and security of cryptosystems from two different points of view. First, we use concepts of conditional probability to discuss the concept of perfect secrecy. We then reformulate the results obtained in terms of entropy, which in turn depends on concepts of conditional probability. For the reader who needs a refresher, the chapter opens with a brief introduction to conditional probability.

All of the concepts in this appendix were first introduced in Shannon's landmark 1949 paper [SHAN49], which is included in the Document section at box.com/Crypto8e.

B.1 CONDITIONAL PROBABILITY

We often want to know a probability that is conditional on some event. The effect of the condition is to remove some of the outcomes from the sample space. For example, what is the probability of getting a sum of 8 on the roll of two dice, if we know that the face of at least one die is an even number? We can reason as follows. Because one die is even and the sum is even, the second die must show an even number. Thus, there are three equally likely successful outcomes: (2, 6), (4, 4) and (6, 2), out of a total set of possibilities of $[36 - (\text{number of events with both faces odd})] = 36 - (3 \times 3) = 27$. The resulting probability is $3/27 = 1/9$.

Formally, the **conditional probability** of an event A assuming the event B has occurred, denoted by $\Pr[A|B]$, is defined as the ratio

$$\Pr[A|B] = \frac{\Pr[AB]}{\Pr[B]}$$

where we assume $\Pr[B]$ is not zero.

In our example, $A = \{\text{sum of 8}\}$ and $B = \{\text{at least one die even}\}$. The quantity $\Pr[AB]$ encompasses all of those outcomes in which the sum is 8 and at least one die is even. As we have seen, there are three such outcomes. Thus, $\Pr[AB] = 3/36 = 1/12$. A moment's thought should convince you that $\Pr[B] = 3/4$. We can now calculate

$$\Pr[A|B] = \frac{1/12}{3/4} = \frac{1}{9}$$

This agrees with our previous reasoning.

Two events A and B are called **independent** if $\Pr[AB] = \Pr[A]\Pr[B]$. It can easily be seen that if A and B are independent, $\Pr[A|B] = \Pr[A]$ and $\Pr[B|A] = \Pr[B]$.

B.2 PERFECT SECRECY

What does it mean that a crypto system is secure? Of course, if the adversary finds the entire plaintext or the entire secret key, that would be a severe failure. But even if the adversary finds a small part of the plaintext or the key, or even if the adversary

determines that, say, the first letter of the plaintext is more likely to be an A than the usual frequency of an A at the beginning of a word in a typical English text, that would also be a weakness.

A cryptosystem is secure against an attack if the adversary does not learn anything after the attack compared to what he/she knew before the attack. In this section, we consider the case of the ciphertext-only attack. The other types of attacks can be formalized similarly. We define two types of secrecy:

- **Perfect secrecy:** The adversary does not learn anything, no matter his/her computational power and how much time the attack takes. This is the ideal, but cannot be realized by practical cryptosystems.
- **Computational secrecy:** The adversary does not learn anything unless he/she is performing more than N operations, where N is some huge number (so that the attack takes thousands of years). This is good enough and may be achieved by practical cryptosystems.

To formally define the notion of secrecy we first introduce some notation:

- M is a random variable that denotes a message chosen from the set of messages \mathcal{M} . M is characterized by its distribution (see example below).
- K is a random variable that denotes the encryption key chosen from the set of keys \mathcal{K} . The key K is chosen uniformly at random (i.e., all the keys are equally likely).
- C is the encryption of M , i.e., $C = E(K, M)$

Simple example: Suppose the message comes from a military base. Assume that the base sends only three messages: “nothing to report,” “attack with 5 planes,” and “attack with 10 planes.” Then $\mathcal{M} = \{\text{“nothing to report,” “attack with 5 planes,” “attack with 10 planes”}\}$

This is called the *set of messages*. We can endow a set of messages with a probability distribution (in short, just *distribution*), indicating how likely each message is. For example, one possible distribution of M can be

$$\begin{pmatrix} \text{nothing to report} & \text{attack with 5 planes} & \text{attack with 10 planes} \\ 0.6 & 0.3 & 0.1 \end{pmatrix}$$

We should assume that the attacker knows the distribution of M (similar to knowing the frequency of letters in English).

We are now in a position to formally define the term **perfect secrecy**, or **perfect security**. Before doing so, it is instructive to quote Shannon’s description.

“Perfect Secrecy” is defined by requiring of a system that after a cryptogram is intercepted by the enemy the *a posteriori* probabilities of this cryptogram representing various messages be identically the same as the *a priori* probabilities of the same messages before the interception. It is shown that perfect secrecy is possible but requires, if the number of messages is finite, the same number of possible keys. If the message is thought of as being constantly generated at a given “rate” R , key must be generated at the same or a greater rate.

We develop two different versions of the definition of perfect secrecy.

Definition 1. An encryption scheme over message space \mathcal{M} is **perfectly secure—version 1**.

If for all distributions M over \mathcal{M} , for any fixed message m and for any fixed ciphertext c , we have

$$\Pr[M = m \mid E(K, M) = c] = \Pr[M = m]$$

Here the probabilities are taken over the distribution of M and over choosing the key K uniformly at random in the space of all keys. We can make the following observations.

1. The definition is equivalent to saying that M and $E(K, M)$ are independent.
2. What the definition is saying: The distribution on M is supposed to be known by the adversary. We require that the cryptosystem does not leak any additional information. This is captured in the definition by saying that knowing the ciphertext c does not change the distribution M .
3. We have argued intuitively (Section 3.2) that the one-time pad has the above property. Now we can prove this assertion rigorously.

Theorem 1. A one-time pad is perfectly secure.

Proof of a special case (the general case is similar): Let $\mathcal{M} = \{0, 1\}$ —just two messages. Let us denote $C = E(K, M) = K \oplus M$. We first observe that

$$\begin{aligned} \Pr[M = 0 \mid C = 0] &= \frac{\Pr[(M = 0) \cap (C = 0)]}{\Pr[C = 0]} = \frac{\Pr[(M = 0) \cap (M \oplus K = 0)]}{\Pr[C = 0]} \\ &= \frac{\Pr[(M = 0) \cap (K = 0)]}{\Pr[C = 0]} = \frac{\Pr[M = 0] \Pr[K = 0]}{\Pr[C = 0]} \end{aligned}$$

Now we show that $\Pr[K = 0] = \Pr[C = 0] = 1/2$. Therefore, these two terms cancel in the above equation yielding $\Pr[M = 0 \mid C = 0] = \Pr[M = 0]$. The same argument applies for the other combinations of M and C .

$\Pr[K = 0] = 1/2$ is obvious, because there are two equally likely keys (namely 0 and 1).

$$\begin{aligned} \Pr[C = 0] &= \Pr[M = 0 \cap K = 0] + \Pr[M = 1 \cap K = 1] \\ &= \Pr[M = 0] \times \Pr[K = 0] + \Pr[M = 1] \times \Pr[K = 1] \\ &= \Pr[M = 0] \times 1/2 + \Pr[M = 1] \times 1/2 \\ &= 1/2 \times (\Pr[M = 0] + \Pr[M = 1]) \\ &= 1/2 \end{aligned}$$

In the case of the one-time pad cryptosystem, the key is as long as the message, which means that the space of keys is as large as the space of messages. The next theorem shows that this is the case for any encryption

scheme that is perfectly secure—version 1. In other words, any encryption scheme that is perfectly secure—version 1 suffers from the same impracticality issue as the one-time pad.

Notation: $||A||$ denotes the number of elements of the finite set A .

Theorem 2. If an encryption scheme is perfectly secure—version 1 over message space \mathcal{M} , then the set of keys \mathcal{K} must satisfy $||\mathcal{K}|| \geq ||\mathcal{M}||$.

Proof. Let c be a ciphertext. Suppose $||\mathcal{K}|| < ||\mathcal{M}||$. Then when we decrypt c with all possible keys, we obtain at most $||\mathcal{K}||$ possible plaintexts. So there is a message m that is not obtained. Then $\Pr[M = m | C = c] = 0$. But clearly we can make a distribution with $\Pr(M = m) > 0$, so this probability relation violates the definition of perfectly secure—version 1.

For example, if we look at messages that are 1000 bits long, there are 2^{1000} possible messages, and we need at least 2^{1000} keys, so a key on average must be at least 1000 bits long. So, a perfectly secure—version 1 is too much to ask, because it can be achieved only by very impractical encryption schemes (such as one-time pad).

The definition of an encryption that is perfectly secure—version 1 may seem to be too abstract and not be very convincing. Let us try another attempt for defining secrecy. This definition has the merit that it models the fact that the adversary does not get anything if she is doing a ciphertext-only attack.

Definition 2. An encryption scheme over message set \mathcal{M} is **perfectly secure—version 2** if for any two messages m_1 and m_2 in \mathcal{M} and for any algorithm A , we have

$$\Pr[A(C) = m_1 | C = E(K, m_1)] = \Pr[A(C) = m_1 | C = E(K, m_2)]$$

We can make the following observations.

1. Think of A as an attacker that wants to guess whether C is the encryption of m_1 or of m_2 .
2. The definition assumes that the enemy does a ciphertext-only attack, because A has as input only C . Security against the other kind of attacks can be defined (more or less) similarly.
3. The probabilities are taken over the random choice of the key from \mathcal{K} (and the random decisions of A if A is a probabilistic algorithm).
4. Instead of equality, suppose that the left-hand side of the above equation is greater than the right-hand side. A successful attacker would have the left-hand side big (ideally 1) and the right-hand side small (ideally 0).
5. The definition says that A is not doing any better at guessing the message when it is given an encryption of m_1 than when it is given an encryption of m_2 .

Theorem 3. Perfectly secure—version 2 = perfectly secure—version 1. (this means that an encryption scheme is secure according to version 1 if and only if it is secure according to version 2).

We omit the proof. It is not hard, but it is long.

Thus, perfectly secure—version 2 cannot be achieved by practical encryption schemes either. So we adopt a more relaxed definition, which is computational secrecy.

Definition 3. Let ε be a small parameter (e.g., $\varepsilon = 0.0001$) and N be a large parameter (e.g., $N = 10^{80}$). An encryption scheme over message space \mathcal{M} is computationally secure (with parameters ε and N) if for any two messages m_1 and m_2 in \mathcal{M} and for any algorithm A that performs N operations, we have:

$$|\Pr[A(C) = m_1 | C = E(K, m_1)] - \Pr[A(C) = m_1 | C = E(K, m_2)]| < \varepsilon$$

We can make the following observations.

1. There are two relaxations compared with “perfectly secure—version 2.”
 - We don’t require equality between the two probabilities, just closeness within ε .
 - And it is acceptable if the attacker can break the system by doing a huge number of operations: if an attacker must spend billions of year to break the cryptosystem, then the cryptosystem is considered secure.
2. The above definition only defines security against ciphertext-only attacks. In the same spirit, we can define computational secrecy against stronger types of attacks, such as chosen plaintext attack, or chosen ciphertext attack.
3. What should be the concrete values for N (the number of operation we allow the adversary to do) and ε (the bias we allow the adversary to achieve)? A common recommendations is that it is acceptable if no adversary running for at most $N = 2^{80}$ CPU cycles can break the system with probability greater than 2^{-64} .

Let’s get a feel for these values. Computation on the order of $N = 2^{60}$ is barely within reach today. Running on a 3-GHz computer (that executes 3×10^9 cycles per second), 2^{60} cycles require $2^{60}/(3 \times 10^9)$ seconds or about 12 years. 2^{80} is $2^{20} \approx 10^6$ times longer than that. The number of seconds since the Big Bang is estimated to be in the order of 2^{58} .

An event that occurs once every hundred years can be roughly estimated to occur with probability 2^{-30} in any given second. Something that occurs with probability 2^{-60} in any given second is 2^{30} times less likely and might be expected to occur roughly once every 100 billion years.

B.3 INFORMATION AND ENTROPY

At the heart of information theory are two mathematical concepts with names that can be misleading: information and entropy. Typically, one thinks of **information** as having something to do with meaning; **entropy** is a term familiar from the second law of thermodynamics. In the discipline of information theory, information has to

do with the reduction in the uncertainty about an event and entropy is an averaging of information values that happens to have a mathematical form identical to that for thermodynamic entropy.

Let us approach this new definition of information by way of an example. Imagine an investor who needs *information* (advice) about the status of certain securities, and who consults a broker with special *information* (knowledge) in that area. The broker *informs* (tells) the investor that, by coincidence, a federal investigator had come by just that morning seeking *information about* (evidence of) possible fraud by the corporation issuing that particular stock. In response to this *information* (data), the investor decides to sell, and so *informs* (notifies) the broker.

Put another way, being *uncertain* how to evaluate a portion of his/her portfolio, the client consults someone more *certain* than he/she about this aspect of the market. The broker relieves his/her client's *uncertainty* about relevant happenings by recounting the visit of the federal investigator, who had *uncertainties* to resolve of a professional nature. As an upshot of his/her increased *certainty* about the state of her securities, the client removes any *uncertainty* in the mind of the broker about her intention to sell.

Although the term *information* may signify notification, knowledge, or simply data, in each case the imparting of information is equivalent to the reduction in uncertainty. Information thus signifies the positive difference between two uncertainty levels.

Information

If we are to deal with information mathematically, then we need some quantity that is appropriate for measuring the amount of **information**. This problem was first raised, and solved, by Hartley in 1928 while studying telegraph communication [HART28]. Hartley observed that if the probability that an event will occur is high (close to 1), there is little uncertainty that it will occur. If we subsequently learn that it has occurred, then the amount of information gained is small. Thus, one plausible measure is the reciprocal of the probability of the occurrence of an event: $1/p$. For example, an event that has an initial probability of occurrence of 0.25 conveys more information by its occurrence than one with an initial probability of 0.5. If the measure of information is $1/p$, then the occurrence of the first event conveys an information value of 4 ($1/0.25$) and the occurrence of the second event conveys an information value of 2 ($1/0.5$). But there are two difficulties in using this measure of information:

1. This measure does not seem to “work” for sequences of events. Consider a binary source that issues a stream of ones and zeros with equal probability of a one or zero for each bit. Thus, each bit has an information value of 2 ($1/0.5$). But if bit b_1 conveys a value of 2, what is the information conveyed by the string of two bits b_1b_2 ? This string can take on one of four possible outcomes, each with probability 0.25; therefore, by the $1/p$ measure, an outcome conveys an information value of 4. Similarly, the information value of 3 bits ($b_1b_2b_3$) is eight. This means that b_2 adds two units of information to the two of b_1 , which is reasonable because the 2 bits have the same information value. But b_3 will add an additional four units of information. Extending the sequence, b_4 will add eight units of information, and so on. This does not seem reasonable as a measure of information.

2. Consider an event that gives rise to two or more independent variables. An example is a phase-shift-keying (PSK) signal that uses four possible phases and two amplitudes. A single signal element yields two units of information for the amplitude and four for the phase, for a total of six units by our measure. Yet each signal element is one of eight possible outcomes and hence ought to yield eight units of information by our measure.

Hartley overcame these problems by proposing that the measure of information for the occurrence of an event x be $\log(1/P(x))$, where $P(x)$ denotes the probability of occurrence of event x . Formally,

$$I(x) = \log(1/P(x)) = -\log P(x) \quad (\text{B.1})$$

This measure “works” and leads to many useful results. The base of the logarithm is arbitrary but is invariably taken to the base 2, in which case the unit of measure is referred to as a bit. The appropriateness of this designation should be obvious as we proceed. Base 2 logarithms are assumed in the rest of this discussion. We can make the following observations:

1. A single bit that takes on the values 0 and 1 with equal probability conveys one bit of information ($\log(1/0.5) = 1$). A string of two such bits takes on one of four equally likely outcomes with probability 0.25 and conveys two bits of information ($\log(1/0.25) = 2$). Therefore, the second bit adds one bit of information. In a sequence of three independent bits, the third bit also adds one bit of information ($\log(1/0.125) = 3$), and so on.
2. In the example of the PSK signal, a single signal element yields one bit of information for the amplitude and two for the phase, for a total of 3 bits, which agrees with the observation that there are eight possible outcomes.

Figure B.1 shows the information content for a single outcome as a function of the probability p of that outcome. As the outcome approaches certainty ($p = 1$), the information conveyed by its occurrence approaches zero. As the outcome approaches impossibility ($p = 0$), its information content approaches infinity.

Entropy

The other important concept in information theory is **entropy**, or **uncertainty**,¹ which was proposed in 1948 by Shannon, the founder of information theory. Shannon defined the entropy H as the average amount of information obtained from the value of a random variable. Suppose we have a random variable X , which may take on the values x_1, x_2, \dots, x_N , and that the corresponding probabilities of each outcome are $P(x_1), P(x_2), \dots, P(x_N)$. In a sequence of K occurrences of X , the outcome x_j will on average be selected $KP(x_j)$ times. Therefore, the average amount of information obtained from K outcomes is [using P_j as an abbreviation for $P(x_j)$]:

$$KP_1 \log(1/P_1) + \dots + KP_N \log(1/P_N)$$

¹ Shannon used the term *entropy* because the form of the function H is the same as the form of the entropy function in statistical thermodynamics. Shannon interchangeably called H the *uncertainty function*.

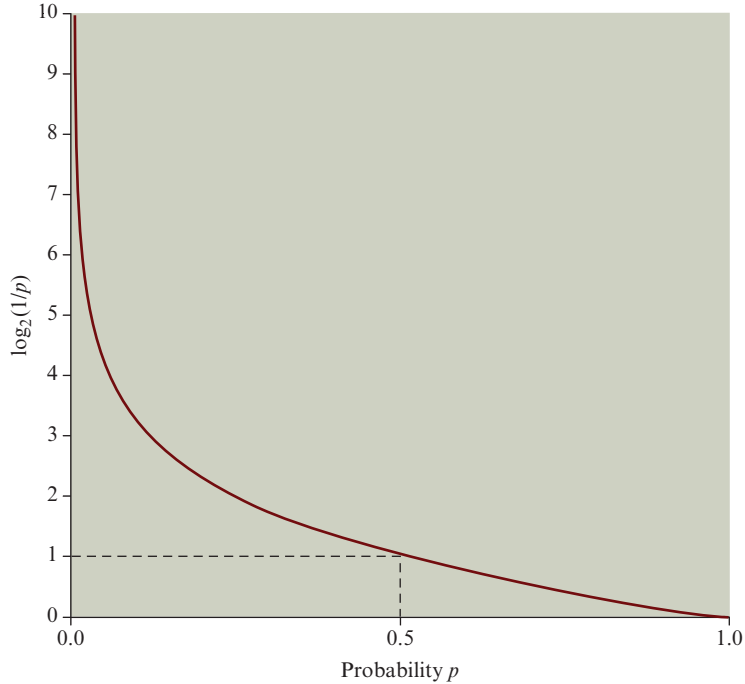

Figure B.1 Information Measure for a Single Outcome

Dividing by K yields the average amount of information per outcome for the random variable, referred to as the entropy of X , and designated by $H(X)$:

$$H(X) = \sum_{j=1}^N P_j \log(1/P_j) = - \sum_{j=1}^N P_j \log(P_j) \quad (\text{B.2})$$

The function H is often expressed as an enumeration of the probabilities of the possible outcomes: $H(P_1, P_2, \dots, P_N)$.

As an example, consider a random variable X that takes on two possible values with respective probabilities p and $1 - p$. The entropy associated with X is

$$H(p, 1 - p) = -p \log(p) - (1 - p) \log(1 - p)$$

Figure B.2 plots $H(X)$ for this case as a function of p . Several important features of entropy are evident from this figure. First, if one of the two events is certain ($p = 1$ or $p = 0$), then the entropy is zero.² One of the two events has to occur and no information is conveyed by its occurrence. Second, the maximum value of $H(X) = 1$ is reached when the two outcomes are equally likely. This seems reasonable: the uncertainty of the outcome is maximum when the two outcomes are equally likely. This result generalizes to a random variable with N outcomes: its entropy is maximum when the outcomes are equally likely:

$$\max H(P_1, P_2, \dots, P_N) = H(1/N, 1/N, \dots, 1/N)$$

² Strictly speaking, the formula for $H(X)$ is undefined at $p = 0$. The value is assumed to be 0 for $p = 0$. This is justified because the limit of $H(X)$ as p goes to 0 is 0.

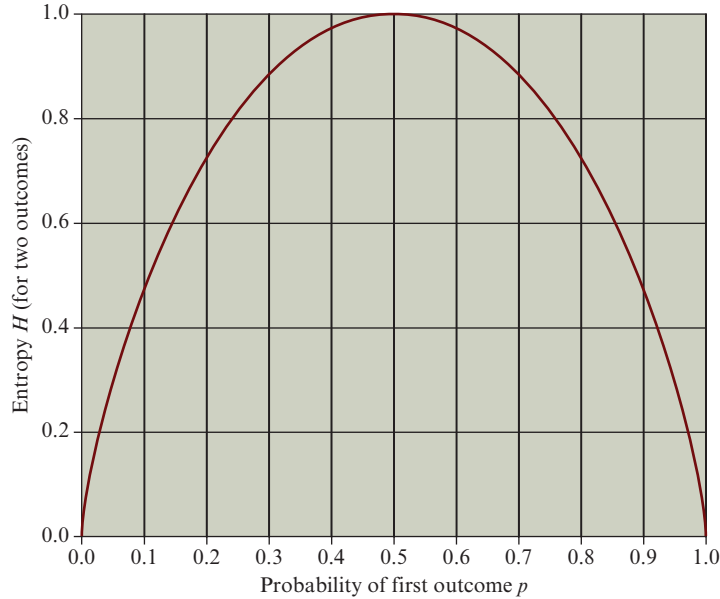

Figure B.2 Entropy Function for Random Variable with Two Outcomes

For example:

$$H(1/3, 1/3, 1/3) = 1/3 \log 3 + 1/3 \log 3 + 1/3 \log 3 = 1.585$$

whereas

$$\begin{aligned} H(1/2, 1/3, 1/6) &= 1/2 \log 2 + 1/3 \log 3 + 1/6 \log 6 = 0.5 + 0.528 + 0.43 \\ &= 1.458 \end{aligned}$$

Properties of the Entropy Function

We have developed the entropy formula $H(X)$ by an intuitive line of reasoning. Another approach is to define the properties that an entropy function should have and then prove that the formula $-\sum_j P_j \log P_j$ is the only formula that has these properties. These properties, or axioms, can be stated as follows:

1. H is continuous over the range of probabilities. Thus, small changes in the probability of one of the occurrences only cause small changes in the uncertainty. This seems a reasonable requirement.
2. If there are N possible outcomes and they are equally likely, so that $P_j = 1/N$, then $H(X)$ is a monotonically increasing function of N . This is also a reasonable property because it says that the more equally likely outcomes, the larger the uncertainty.
3. If some of the outcomes of X are grouped, then H can be expressed as a weighted sum of entropies in the following fashion:

$$H(P_1, P_2, P_3, \dots, P_N) = H(P_1 + P_2, P_3, \dots, P_N) + (P_1 + P_2)H\left(\frac{P_1}{P_1 + P_2}, \frac{P_2}{P_1 + P_2}\right)$$

The reasoning is as follows. Before the outcome is known, the average uncertainty associated with the outcome is $H(P_1, P_2, P_3, \dots, P_N)$. If we reveal which outcome has occurred, except that the first two outcomes are grouped together, then the average amount of uncertainty removed is $H(P_1 + P_2, P_3, \dots, P_N)$. With probability $(P_1 + P_2)$, one of the first two outcomes occurs and the remaining uncertainty is $H[P_1/(P_1 + P_2) + P_2/(P_1 + P_2)]$.

The only definition of $H(X)$ that satisfies all three properties is the one that we have given. To see property (1), consider Figure B.2, which is clearly continuous in p . It is more difficult to depict $H(X)$ when there are more than two possible outcomes, but the fact of continuity should be clear.

For property (2), if there are N equally likely outcomes, then $H(X)$ becomes

$$H(X) = -\sum_{j=1}^N \frac{1}{N} \log\left(\frac{1}{N}\right) = -\log\left(\frac{1}{N}\right) = \log(N)$$

The function $\log(N)$ is a monotonically increasing function of N . Note that with four possible outcomes, the entropy is 2 bits; with eight possible outcomes, the entropy is 3 bits, and so on.

As a numerical example of property (3), we may write

$$\begin{aligned} H\left(\frac{1}{2}, \frac{1}{3}, \frac{1}{6}\right) &= H\left(\frac{5}{6}, \frac{1}{6}\right) + \frac{5}{6}H\left(\frac{3}{5}, \frac{2}{5}\right) \\ 1.458 &= 0.219 + 0.43 + \frac{5}{6}(0.442 + 0.5288) \\ &= 0.649 + 0.809 \end{aligned}$$

Conditional Entropy

Shannon defines the conditional entropy of Y given X , expressed as $H(Y|X)$, as the uncertainty about Y given knowledge of X . This conditional entropy is defined as follows:

$$H(Y|X) = -\sum_{x,y} \Pr(x, y) \log \Pr(y|x)$$

where

$x = a$ value contained in the set X

$y = a$ value contained in the set Y

$\Pr(x, y)$ = probability of the joint occurrence of x for the value in X and y for the value in Y .

Conditional uncertainties obey intuitively pleasing rules, such as:

$$H(X, Y) = H(X) + H(Y|X)$$

B.4 ENTROPY AND SECURITY

For a symmetric encryption system, the basic equations are $C = E(K, M)$ and $M = E(K, C)$. These equations can be written equivalently, in terms of uncertainties as

$$H(C|K, M) = 0$$

and

$$H(M|K, C) = 0 \tag{B.3}$$

respectively, because, for instance $H(C|K, M)$ is zero if and only if, M and K uniquely determine C , which is a basic requirement of symmetric encryption.

Shannon's definition of perfect secrecy can then be written as:

$$H(M|C) = H(M) \tag{B.4}$$

because this equality holds if and only if M is statistically independent of C .

For any secret key cryptosystem, we can write

$$\begin{aligned} H(M|C) &\leq H(M, K|C) \\ &= H(K|C) + H(M|K, C) \\ &= H(K|C) \\ &\leq H(K) \end{aligned} \tag{B.5}$$

where we have used Equation (B.3) and the fact that removal of given knowledge can only increase uncertainty. If the cryptosystem provides perfect secrecy, it follows from Equations (B.4) and (B.5) that

$$H(K) \geq H(M) \tag{B.6}$$

Inequality (B.6) is Shannon's fundamental bound for perfect secrecy. The uncertainty of the secret key must be at least as great as the uncertainty of the plaintext that it is concealing. Let us assume we are dealing with binary values; that is, the plaintext, key, and ciphertext are represented as binary strings. Then we can say that for a key of length k bits,

$$H(K) \leq -\log(2^{-k}) = k \tag{B.7}$$

with equality if and only if the key is completely random. Similarly, if the length of the plaintext is q , then

$$H(M) \leq -\log(2^{-q}) = q \tag{B.8}$$

with equality if and only if the plaintext is completely random, which means each q -bit plaintext is equally likely to occur. Combining inequalities (B.6, B.7, B.8), the requirement for perfect secrecy if the plaintext is completely random is $k \geq q$. That is, the key must be at least as long as the plaintext. For the one-time pad, we have $k = q$.

B.5 MIN-ENTROPY

A concept that is increasingly significant in cryptographic applications is min-entropy. Before looking at a mathematical definition, it will be useful in understanding the significance of min-entropy to look at two definitions from NIST.

NIST 800-90C (*Recommendation for Random Bit Generator Constructions*, August 2012) gives the following definition:

The min-entropy (in bits) of a random variable X is the largest value m having the property that each observation of X provides at least m bits of information (i.e., the min-entropy of X is the greatest lower bound for the information content of potential observations of X). The min-entropy of a random variable is a lower bound on its entropy. Min-entropy is often used as a worst-case measure of the unpredictability of a random variable.

NIST800-63-1 (*Electronic Authentication Guideline*, December 2008) defines min-entropy as follows:

A measure of the difficulty that an Attacker has to guess the most commonly chosen password used in a system. In this document, entropy is stated in bits. When a password has n bits of min-entropy, then an Attacker requires as many trials to find a user with that password as is needed to guess an n -bit random quantity. The Attacker is assumed to know the most commonly used password(s).

Let us now define min-entropy mathematically and confine ourselves to cryptographic keys of length k bits. Thus, the key K can take on one of $N = 2^k$ values in the range $0 \leq K \leq (2^k - 1)$. If each value of K is equally likely, then each value occurs with probability $2^{-k} = 1/N$ and the uncertainty, or entropy, associated with K can be expressed as:

$$H(K) = \sum_{j=1}^N P_j \log(1/P_j) = \sum_{j=1}^N 2^{-k} \log(2^k) = k \sum_{j=1}^N 2^{-k} = k \sum_{j=1}^N \frac{1}{N} = k$$

where

$$\begin{aligned} P_j &= \text{probability that the key value} = j - 1 \quad (\text{e.g., } P_1 = \Pr[K = 0]); \\ P_N &= \Pr[K = 2^k - 1] \\ N &= 2^k \end{aligned}$$

In this situation, there are k bits of information and an adversary would have to try an average of half the values, or 2^{k-1} , before correctly guessing the key value.

Now, suppose that the key value is generated by a pseudorandom number generator. If the PRNG exhibits perfect randomness, then each possible key value is equally likely. However, if the PRNG has some bias or skew, then at least some of

the key values will have a probability that is greater or less than 2^{-k} , with the proviso that $\sum_{j=1}^N P_j = 1$.

For this circumstance, it is useful to define the min-entropy $H_\infty(K)$ as follows:

$$H_\infty(K) = \min\left(\log\left(\frac{1}{P_j}\right)\right) = \log\left(\min\left(\frac{1}{P_j}\right)\right) = -\log(\max(P_j))$$

Another way of wording this is as follows:

A k -bit random key K has min-entropy at least n , if for every j , $0 \leq j < 2^k$, it holds that $\Pr[K = j] \leq 2^{-n}$. Note that we must have $n \leq k$.

If all of the outcomes are equally likely (i.e., if $P_j = 2^{-k}$ for $0 \leq j < 2^k$), then $H_\infty(K) = H(K) = k$. But if not all outcomes are equally likely, then $H_\infty(K) < H(K)$, and the value of $H_\infty(K)$ is determined by the most likely outcome. So, for example, if outcome j is twice as likely to occur as the average outcome ($P_j = 2^{-k+1}$), and is the most likely outcome, then $H_\infty(K) = k - 1$. Another way to describe this formulation is that if K has min-entropy m , then the probability of observing any particular value is no greater than 2^{-m} .

Let us look at a simple example of a 3-bit key. If all of the outcomes are equally likely, then $H(K) = 3$, so that a key value provides 3 bits of information. Now suppose the probability distribution is not uniform, as indicated in the following table:

I	P_i	$\log(1/P_i)$	$P_i \log(1/P_i)$
0	1/16	4	1/4
1	1/4	2	1/2
2	1/8	3	3/8
3	1/8	3	3/8
4	1/16	4	1/4
5	1/16	4	1/4
6	1/8	3	3/8
7	3/16	$\log(16) - \log(3) \approx 2.415$	≈ 0.453

Then we have:

$$H(K) = \sum_{i=1}^8 P_i \log(1/P_i) = \frac{1}{4} + \frac{1}{2} + \frac{3}{8} + \frac{3}{8} + \frac{1}{4} + \frac{1}{4} + \frac{3}{8} + 0.453 = 2.828$$

$$H_\infty(K) = \min\left(\log\left(\frac{1}{P_i}\right)\right) = 2$$

Thus, the average entropy of a sample is 2.828 bits, and every sample has at least 2 bits of entropy.

How does all this relate to the security of a key? We have stated that if all of the 2^k possible values of a k -bit key are equally likely, then an adversary would have to attempt, on average, $2^k/2 = 2^{k-1}$ values to successfully guess the actual key value.

That is, the adversary has a level of effort of $2^{k-1} = 2^{H(K)-1}$. If, however, the PRNG source that produced the key is not truly random, then the key variable will have an entropy $H(K) < k$. It will still take, on average, a level of effort of $2^{H(K)-1}$ to discover a key. More importantly, the worst-case level of effort is just $2^{H_{\infty}(K)-1}$.

A simple example may help to make this clear. Suppose the PRNG used to generate a key has a bias so that it produces, on average, more 1s than 0s. If the adversary knows this, then the adversary can proceed to first guess keys with more 1s than 0s and thus find the actual key more quickly than if everything were completely random. The same argument applies to a hardware RNG, which is assumed to be a true RNG but which in fact has some bias or skew. This is why RNGs such as Intel use cryptographic algorithms on the output of a hardware RNG to eliminate bias and maximize entropy. More specifically, such schemes are designed to maximize min-entropy.

APPENDIX C

DATA ENCRYPTION STANDARD

The overall scheme for DES encryption is illustrated in Figure C.1, which repeats Figure 4.5. As with any encryption scheme, there are two inputs to the encryption function: the plaintext to be encrypted and the key. In this case, the plaintext must be 64 bits in length and the key is 56 bits in length.¹

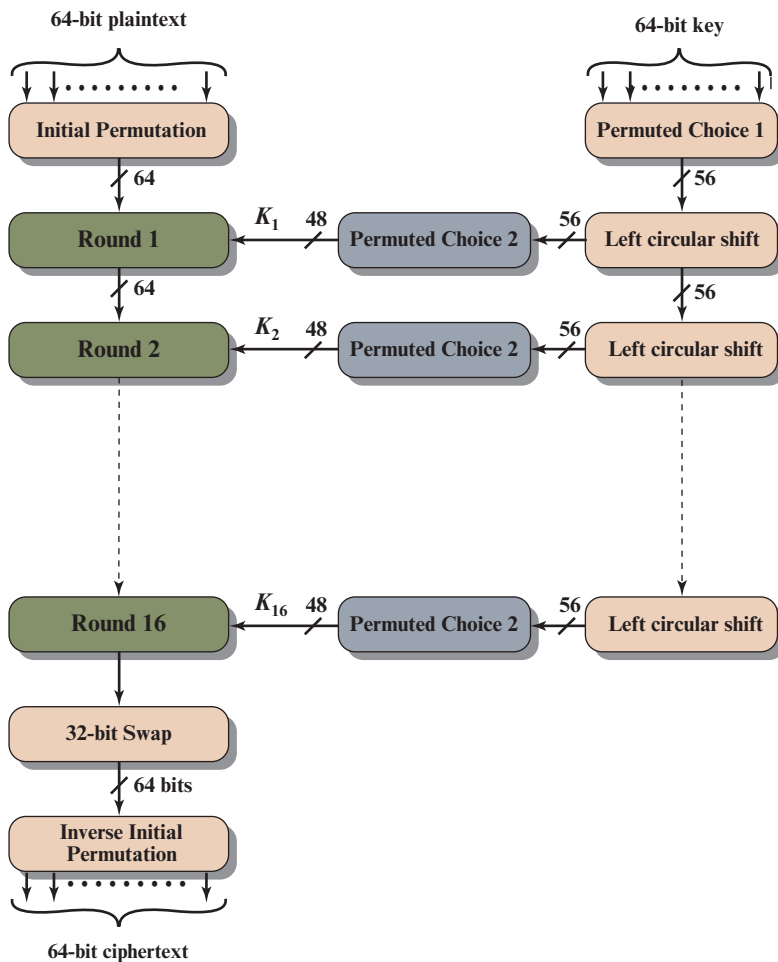

Figure C.1 General Depiction of DES Encryption Algorithm

¹Actually, the function expects a 64-bit key as input. However, only 56 of these bits are ever used; the other 8 bits can be used as parity bits or simply set arbitrarily.

Looking at the left-hand side of the figure, we can see that the processing of the plaintext proceeds in three phases. First, the 64-bit plaintext passes through an initial permutation (IP) that rearranges the bits to produce the *permuted input*. This is followed by a phase consisting of 16 rounds of the same function, which involves both permutation and substitution functions. The output of the last (sixteenth) round consists of 64 bits that are a function of the input plaintext and the key. The left and right halves of the output are swapped to produce the **preoutput**. Finally, the preoutput is passed through a permutation (IP^{-1}) that is the inverse of the initial permutation function, to produce the 64-bit ciphertext. With the exception of the initial and final permutations, DES has the exact structure of a Feistel cipher, as shown in Figure 4.3.

The right-hand portion of Figure C.1 shows the way in which the 56-bit key is used. Initially, the key is passed through a permutation function. Then, for each of the 16 rounds, a *subkey* (K_i) is produced by the combination of a left circular shift and a permutation. The permutation function is the same for each round, but a different subkey is produced because of the repeated shifts of the key bits.

Initial Permutation

The initial permutation and its inverse are defined by tables, as shown in Tables C.1a and C.1b, respectively. The tables are to be interpreted as follows. The input to a table consists of 64 bits numbered from 1 to 64. The 64 entries in the permutation table contain a permutation of the numbers from 1 to 64. Each entry in the permutation table indicates the position of a numbered input bit in the output, which also consists of 64 bits.

Table C.1 Permutation Tables for DES

(a) Initial Permutation (IP)							
58	50	42	34	26	18	10	2
60	52	44	36	28	20	12	4
62	54	46	38	30	22	14	6
64	56	48	40	32	24	16	8
57	49	41	33	25	17	9	1
59	51	43	35	27	19	11	3
61	53	45	37	29	21	13	5
63	55	47	39	31	23	15	7

(b) Inverse Initial Permutation (IP⁻¹)							
40	8	48	16	56	24	64	32
39	7	47	15	55	23	63	31
38	6	46	14	54	22	62	30
37	5	45	13	53	21	61	29
36	4	44	12	52	20	60	28
35	3	43	11	51	19	59	27
34	2	42	10	50	18	58	26
33	1	41	9	49	17	57	25

(c) Expansion Permutation (E)					
32	1	2	3	4	5
4	5	6	7	8	9
8	9	10	11	12	13
12	13	14	15	16	17
16	17	18	19	20	21
20	21	22	23	24	25
24	25	26	27	28	29
28	29	30	31	32	1

(d) Permutation Function (P)							
16	7	20	21	29	12	28	17
1	15	23	26	5	18	31	10
2	8	24	14	32	27	3	9
19	13	30	6	22	11	4	25

To see that these two permutation functions are indeed the inverse of each other, consider the following 64-bit input M :

M_1	M_2	M_3	M_4	M_5	M_6	M_7	M_8
M_9	M_{10}	M_{11}	M_{12}	M_{13}	M_{14}	M_{15}	M_{16}
M_{17}	M_{18}	M_{19}	M_{20}	M_{21}	M_{22}	M_{23}	M_{24}
M_{25}	M_{26}	M_{27}	M_{28}	M_{29}	M_{30}	M_{31}	M_{32}
M_{33}	M_{34}	M_{35}	M_{36}	M_{37}	M_{38}	M_{39}	M_{40}
M_{41}	M_{42}	M_{43}	M_{44}	M_{45}	M_{46}	M_{47}	M_{48}
M_{49}	M_{50}	M_{51}	M_{52}	M_{53}	M_{54}	M_{55}	M_{56}
M_{57}	M_{58}	M_{59}	M_{60}	M_{61}	M_{62}	M_{63}	M_{64}

where M_i is a binary digit. Then the permutation $X = IP(M)$ is as follows:

M_{58}	M_{50}	M_{42}	M_{34}	M_{26}	M_{18}	M_{10}	M_2
M_{60}	M_{52}	M_{44}	M_{36}	M_{28}	M_{20}	M_{12}	M_4
M_{62}	M_{54}	M_{46}	M_{38}	M_{30}	M_{22}	M_{14}	M_6
M_{64}	M_{56}	M_{48}	M_{40}	M_{32}	M_{24}	M_{16}	M_8
M_{57}	M_{49}	M_{41}	M_{33}	M_{25}	M_{17}	M_9	M_1
M_{59}	M_{51}	M_{43}	M_{35}	M_{27}	M_{19}	M_{11}	M_3
M_{61}	M_{53}	M_{45}	M_{37}	M_{29}	M_{21}	M_{13}	M_5
M_{63}	M_{55}	M_{47}	M_{39}	M_{31}	M_{23}	M_{15}	M_7

If we then take the inverse permutation $Y = IP^{-1}(X) = IP^{-1}(IP(M))$, it can be seen that the original ordering of the bits is restored.

Details of Single Round

Figure C.2 shows the internal structure of a single round. Again, begin by focusing on the left-hand side of the diagram. The left and right halves of each 64-bit intermediate value are treated as separate 32-bit quantities, labeled L (left) and R (right).

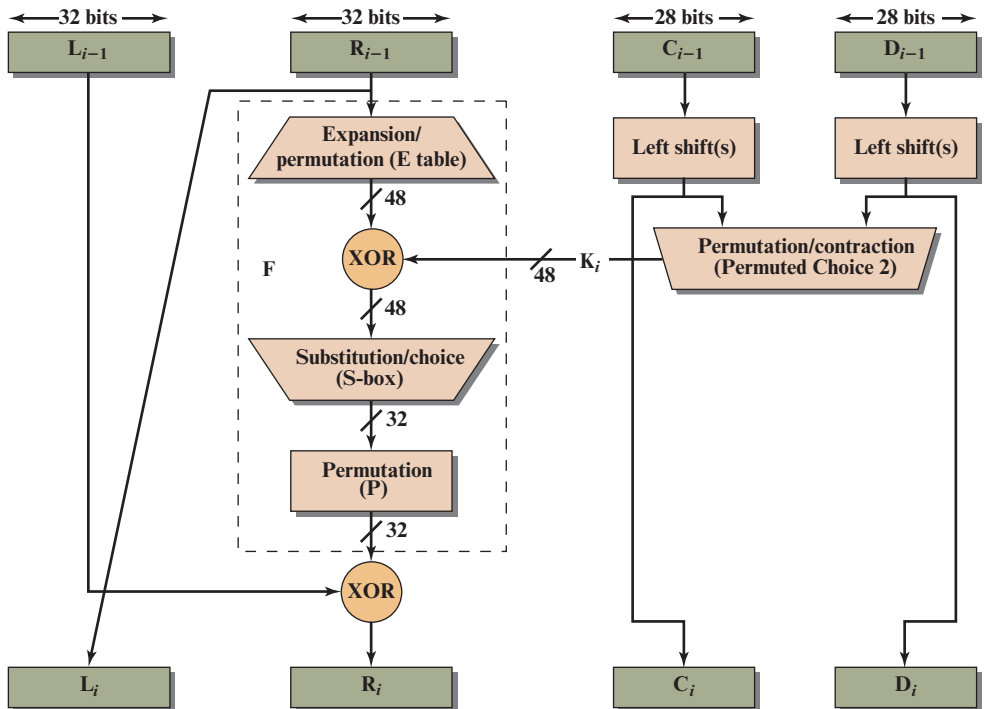

Figure C.2 Single Round of DES Algorithm

As in any classic Feistel cipher, the overall processing at each round can be summarized in the following formulas:

$$L_i = R_{i-1}$$

$$R_i = L_{i-1} \oplus F(R_{i-1}, K_i)$$

The round key K_i is 48 bits. The R input is 32 bits. This R input is first expanded to 48 bits by using a table that defines a permutation plus an expansion that involves duplication of 16 of the R bits (Table C.1c). The resulting 48 bits are XORed with K_i . This 48-bit result passes through a substitution function that produces a 32-bit output, which is permuted as defined by Table C.1d.

The role of the S-boxes in the function F is illustrated in Figure C.3. The substitution consists of a set of eight S-boxes, each of which accepts 6 bits as input and produces 4 bits as output. These transformations are defined in Table C.2, which is interpreted as follows: The first and last bits of the input to box S_i form a 2-bit binary number to select one of four substitutions defined by the four rows in the table for S_i . The middle four bits select one of the 16 columns. The decimal value in the cell selected by the row and column is then converted to its 4-bit representation to produce the output. For example, in S_1 , for input 011001, the row is 01 (row 1) and the column is 1100 (column 12). The value in row 1, column 12 is 9, so the output is 1001.

Each row of an S-box defines a general reversible substitution. Figure 4.2 may be useful in understanding the mapping. The figure shows the substitution for row 0 of box S_1 .

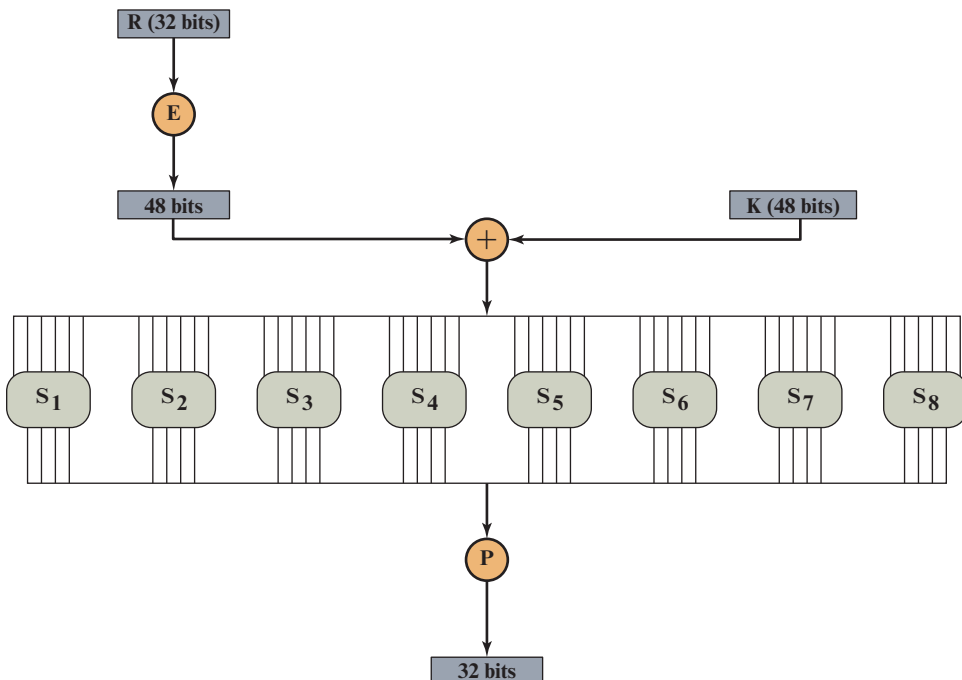

Figure C.3 Calculation of $F(R, K)$

Table C.2 Definition of DES S-Boxes

S_1	14	4	13	1	2	15	11	8	3	10	6	12	5	9	0	7
	0	15	7	4	14	2	13	1	10	6	12	11	9	5	3	8
	4	1	14	8	13	6	2	11	15	12	9	7	3	10	5	0
	15	12	8	2	4	9	1	7	5	11	3	14	10	0	6	13
S_2	15	1	8	14	6	11	3	4	9	7	2	13	12	0	5	10
	3	13	4	7	15	2	8	14	12	0	1	10	6	9	11	5
	0	14	7	11	10	4	13	1	5	8	12	6	9	3	2	15
	13	8	10	1	3	15	4	2	11	6	7	12	0	5	14	9
S_3	10	0	9	14	6	3	15	5	1	13	12	7	11	4	2	8
	13	7	0	9	3	4	6	10	2	8	5	14	12	11	15	1
	13	6	4	9	8	15	3	0	11	1	2	12	5	10	14	7
	1	10	13	0	6	9	8	7	4	15	14	3	11	5	2	12
S_4	7	13	14	3	0	6	9	10	1	2	8	5	11	12	4	15
	13	8	11	5	6	15	0	3	4	7	2	12	1	10	14	9
	10	6	9	0	12	11	7	13	15	1	3	14	5	2	8	4
	3	15	0	6	10	1	13	8	9	4	5	11	12	7	2	14
S_5	2	12	4	1	7	10	11	6	8	5	3	15	13	0	14	9
	14	11	2	12	4	7	13	1	5	0	15	10	3	9	8	6
	4	2	1	11	10	13	7	8	15	9	12	5	6	3	0	14
	11	8	12	7	1	14	2	13	6	15	0	9	10	4	5	3
S_6	12	1	10	15	9	2	6	8	0	13	3	4	14	7	5	11
	10	15	4	2	7	12	9	5	6	1	13	14	0	11	3	8
	9	14	15	5	2	8	12	3	7	0	4	10	1	13	11	6
	4	3	2	12	9	5	15	10	11	14	1	7	6	0	8	13
S_7	4	11	2	14	15	0	8	13	3	12	9	7	5	10	6	1
	13	0	11	7	4	9	1	10	14	3	5	12	2	15	8	6
	1	4	11	13	12	3	7	14	10	15	6	8	0	5	9	2
	6	11	13	8	1	4	10	7	9	5	0	15	14	2	3	12
S_8	13	2	8	4	6	15	11	1	10	9	3	14	5	0	12	7
	1	15	13	8	10	3	7	4	12	5	6	11	0	14	9	2
	7	11	4	1	9	12	14	2	0	6	10	13	15	3	5	8
	2	1	14	7	4	10	8	13	15	12	9	0	3	5	6	11

The operation of the S-boxes is worth further comment. Ignore for the moment the contribution of the key (K_i). If you examine the expansion table, you see that the 32 bits of input are split into groups of 4 bits and then become groups of 6 bits by taking the outer bits from the two adjacent groups. For example, if part of the input word is

... efgh ijkl mnop ...

this becomes

... defghi hijklm lmnopq ...

The outer two bits of each group select one of four possible substitutions (one row of an S-box). Then a 4-bit output value is substituted for the particular 4-bit input (the middle four input bits). The 32-bit output from the eight S-boxes is then permuted, so that on the next round, the output from each S-box immediately affects as many others as possible.

KEY GENERATION Returning to Figures C.1 and C.2, we see that a 64-bit key is used as input to the algorithm. The bits of the key are numbered from 1 through 64; every eighth bit is ignored, as indicated by the lack of shading in Table C.3a. The key is first subjected to a permutation governed by a table labeled Permuted Choice One (Table C.3b). The resulting 56-bit key is then treated as two 28-bit quantities, labeled C_0 and D_0 . At each round, C_{i-1} and D_{i-1} are separately subjected to a circular left shift, or rotation, of 1 or 2 bits, as governed by Table C.3d. These shifted values serve as input to the next round. They also serve as input to Permuted Choice Two (Table C.3c), which produces a 48-bit output that serves as input to the function $F(R_{i-1}, K_i)$.

Table C.3 DES Key Schedule Calculation

(a) Input Key							
1	2	3	4	5	6	7	8
9	10	11	12	13	14	15	16
17	18	19	20	21	22	23	24
25	26	27	28	29	30	31	32
33	34	35	36	37	38	39	40
41	42	43	44	45	46	47	48
49	50	51	52	53	54	55	56
57	58	59	60	61	62	63	64

(b) Permuted Choice One (PC-1)						
57	49	41	33	25	17	9
1	58	50	42	34	26	18
10	2	59	51	43	35	27
19	11	3	60	52	44	36
63	55	47	39	31	23	15
7	62	54	46	38	30	22
14	6	61	53	45	37	29
21	13	5	28	20	12	4

(c) Permuted Choice Two (PC-2)							
14	17	11	24	1	5	3	28
15	6	21	10	23	19	12	4
26	8	16	7	27	20	13	2
41	52	31	37	47	55	30	40
51	45	33	48	44	49	39	56
34	53	46	42	50	36	29	32

(d) Schedule of Left Shifts																
Round Number	1	2	3	4	5	6	7	8	9	10	11	12	13	14	15	16
Bits Rotated	1	1	2	2	2	2	2	2	1	2	2	2	2	2	2	1

DES Decryption

As with any Feistel cipher, decryption uses the same algorithm as encryption, except that the application of the subkeys is reversed.

SIMPLIFIED AES

D.1 Overview

D.2 S-AES Encryption and Decryption

Add Key

Nibble Substitution

Shift Row

Mix Column

D.3 Key Expansion

D.4 The S-Box

D.5 S-AES Structure

ANNEX D.1 Arithmetic in $GF(2^4)$

ANNEX D.2 The Mix Column Function

Simplified AES (S-AES) was developed by Professor Edward Schaefer of Santa Clara University and several of his students [MUSA03]. It is an educational rather than a secure encryption algorithm. It has similar properties and structure to AES with much smaller parameters. The reader might find it useful to work through an example by hand while following the discussion in this appendix. A good grasp of S-AES will make it easier for the student to appreciate the structure and workings of AES.

D.1 OVERVIEW

Figure D.1 illustrates the overall structure of S-AES. The encryption algorithm takes a 16-bit block of plaintext as input and a 16-bit key and produces a 16-bit block of ciphertext as output. The S-AES decryption algorithm takes an 16-bit block of ciphertext and the same 16-bit key used to produce that ciphertext as input and produces the original 16-bit block of plaintext as output.

The encryption algorithm involves the use of four different functions, or transformations: add key (A_K), nibble substitution (NS), shift row (SR), and mix column (MC), whose operation is explained subsequently.

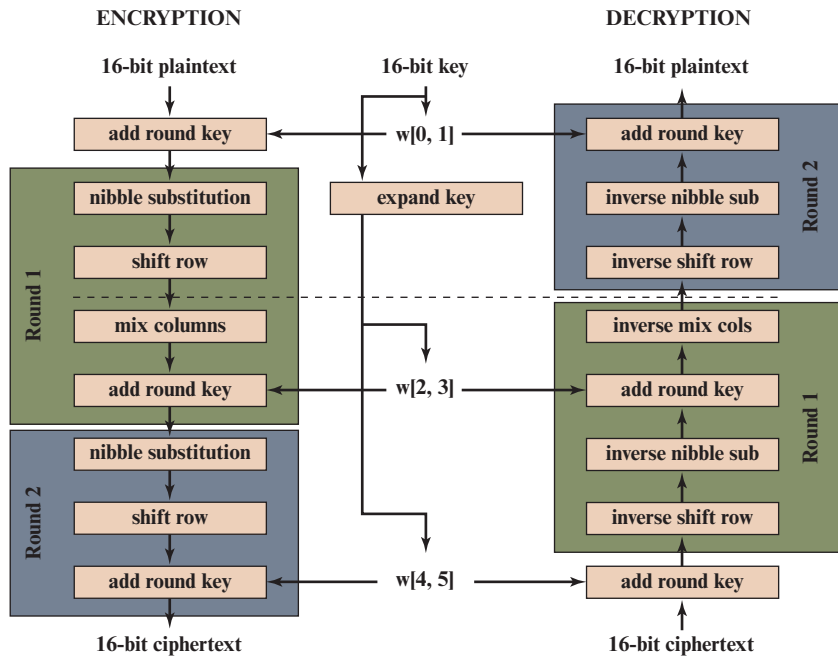

Figure D.1 S-AES Encryption and Decryption

¹**Definition:** If f and g are two functions, then the function F with the equation $y = F(x) = g[f(x)]$ is called the **composition** of f and g and is denoted as $F = g \circ f$.

We can concisely express the encryption algorithm as a composition¹ of functions:

$$A_{K_2} \circ SR \circ NS \circ A_{K_1} \circ MC \circ SR \circ NS \circ A_{K_0}$$

so that A_{K_0} is applied first.

The encryption algorithm is organized into three rounds. Round 0 is simply an add key round; round 1 is a full round of four functions; and round 2 contains only three functions. Each round includes the add key function, which makes use of 16 bits of key. The initial 16-bit key is expanded to 48 bits, so that each round uses a distinct 16-bit round key.

Each function operates on a 16-bit state, treated as a 2×2 matrix of nibbles, where one nibble equals 4 bits. The initial value of the **State** matrix is the 16-bit plaintext; **State** is modified by each subsequent function in the encryption process, producing after the last function the 16-bit ciphertext. As Figure D.2a shows, the ordering of nibbles within the matrix is by column. So, for example, the first 8 bits of a 16-bit plaintext input to the encryption cipher occupy the first column of the matrix, and the second 8 bits occupy the second column. The 16-bit key is similarly organized, but it is somewhat more convenient to view the key as two bytes rather than four nibbles (Figure D.2b). The expanded key of 48 bits is treated as three round keys, whose bits are labeled as follows: $K_0 = k_0 \dots k_{15}$; $K_1 = k_{16} \dots k_{31}$; and $K_2 = k_{32} \dots k_{47}$.

Figure D.3 shows the essential elements of a full round of S-AES.

Decryption is also shown in Figure D.1 and is essentially the reverse of encryption:

$$A_{K_0} \circ INS \circ ISR \circ IMC \circ A_{K_1} \circ INS \circ ISR \circ A_{K_2}$$

in which three of the functions have a corresponding inverse function: inverse nibble substitution (INS), inverse shift row (ISR), and inverse mix column (IMC).

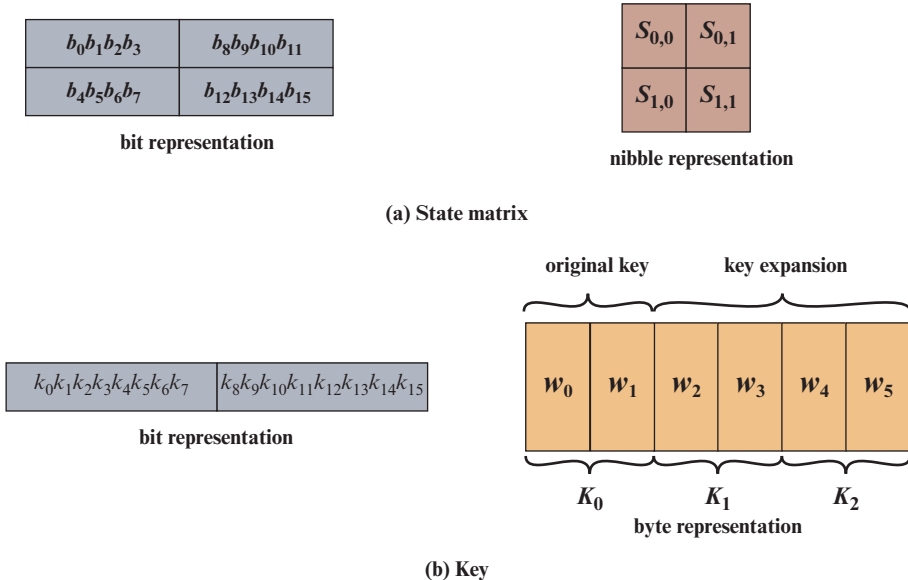

Figure D.2 S-AES Data Structures

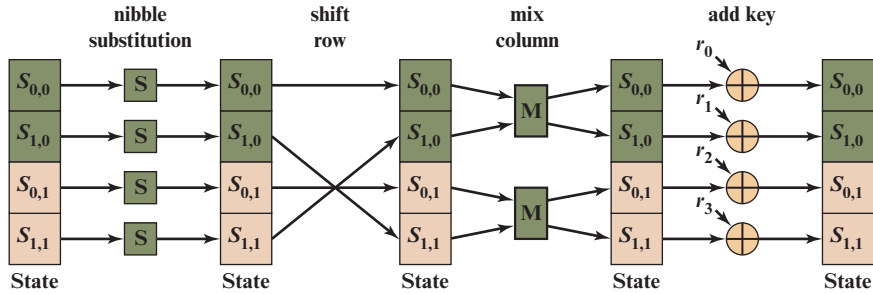

Figure D.3 S-AES Encryption Round

D.2 S-AES ENCRYPTION AND DECRYPTION

We now look at the individual functions that are part of the encryption algorithm.

Add Key

The add key function consists of the bitwise XOR of the 16-bit **State** matrix and the 16-bit round key. Figure D.4 depicts this as a columnwise operation, but it can also be viewed as a nibble-wise or bitwise operation. The following is an example.

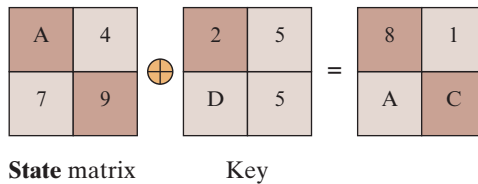

The inverse of the add key function is identical to the add key function, because the XOR operation is its own inverse.

Nibble Substitution

The nibble substitution function is a simple table lookup (Figure D.4). AES defines a 4×4 matrix of nibble values, called an S-box (Table D.1a), that contains a permutation of all possible 4-bit values. Each individual nibble of **State** is mapped into a new nibble in the following way: The leftmost 2 bits of the nibble are used as a row value and the rightmost 2 bits are used as a column value. These row and column values serve as indexes into the S-box to select a unique 4-bit output value. For example, the hexadecimal value A references row 2, column 2 of the S-box, which contains the value 0. Accordingly, the value A is mapped into the value 0.

Here is an example of the nibble substitution transformation.

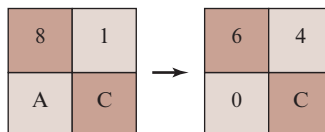

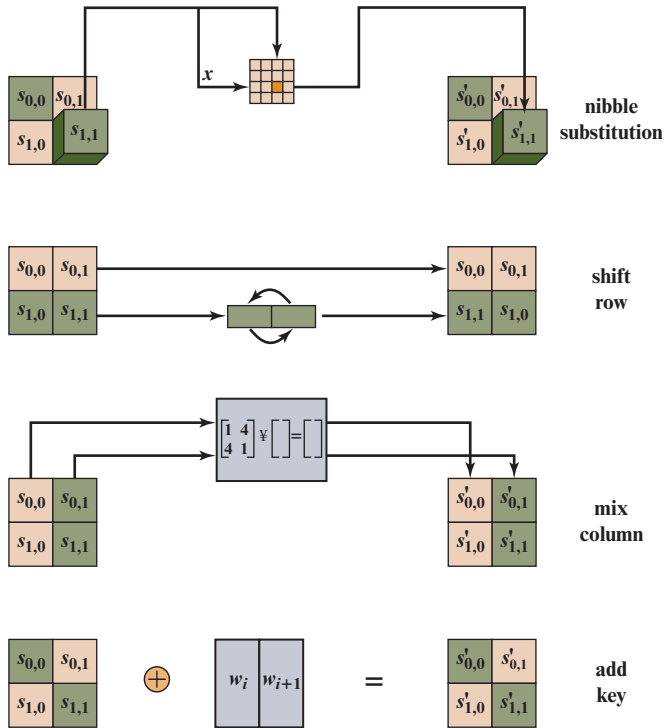

Figure D.4 S-AES Transformations

Table D.1 S-AES S-Boxes

		<i>j</i>			
		00	01	10	11
<i>i</i>	00	9	4	A	B
	01	D	1	8	5
	10	6	2	0	3
	11	C	E	F	7

(a) S-Box

		<i>j</i>			
		00	01	10	11
<i>i</i>	00	A	5	9	B
	01	1	7	8	F
	10	6	0	2	3
	11	C	4	D	E

(b) Inverse S-Box

Note: Hexadecimal numbers in shaded boxes; binary numbers in unshaded boxes.

The inverse nibble substitution function makes use of the inverse S-box shown in Table D.1b. Note, for example, that the input 0 produces the output A, and the input A to the S-box produces 0.

Shift Row

The shift row function performs a one-nibble circular shift of the second row of **State**; the first row is not altered (Figure D.4). The following is an example.

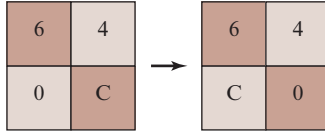

The inverse shift row function is identical to the shift row function, because it shifts the second row back to its original position.

Mix Column

The mix column function operates on each column individually. Each nibble of a column is mapped into a new value that is a function of both nibbles in that column. The transformation can be defined by the following matrix multiplication on **State** (Figure D.4):

$$\begin{bmatrix} 1 & 4 \\ 4 & 1 \end{bmatrix} \begin{bmatrix} s_{0,0} & s_{0,1} \\ s_{1,0} & s_{1,1} \end{bmatrix} = \begin{bmatrix} s'_{0,0} & s'_{0,1} \\ s'_{1,0} & s'_{1,1} \end{bmatrix}$$

Performing the matrix multiplication, we get

$$\begin{aligned} s'_{0,0} &= s_{0,0} \oplus (4 \bullet s_{1,0}) \\ s'_{1,0} &= (4 \bullet s_{0,0}) \oplus s_{1,0} \\ s'_{0,1} &= s_{0,1} \oplus (4 \bullet s_{1,1}) \\ s'_{1,1} &= (4 \bullet s_{0,1}) \oplus s_{1,1} \end{aligned}$$

Where arithmetic is performed in $\text{GF}(2^4)$, and the symbol \bullet refers to multiplication in $\text{GF}(2^4)$. Annex D.1 provides the addition and multiplication tables. The following is an example.

$$\begin{bmatrix} 1 & 4 \\ 4 & 1 \end{bmatrix} \begin{bmatrix} 6 & 4 \\ C & 0 \end{bmatrix} = \begin{bmatrix} 3 & 4 \\ 7 & 3 \end{bmatrix}$$

The inverse mix column function is defined as

$$\begin{bmatrix} 9 & 2 \\ 2 & 9 \end{bmatrix} \begin{bmatrix} s_{0,0} & s_{0,1} \\ s_{1,0} & s_{1,1} \end{bmatrix} = \begin{bmatrix} s'_{0,0} & s'_{0,1} \\ s'_{1,0} & s'_{1,1} \end{bmatrix}$$

We demonstrate that we have indeed defined the inverse in the following fashion.

$$\begin{bmatrix} 9 & 2 \\ 2 & 9 \end{bmatrix} \begin{bmatrix} 1 & 4 \\ 4 & 1 \end{bmatrix} \begin{bmatrix} s_{0,0} & s_{0,1} \\ s_{1,0} & s_{1,1} \end{bmatrix} = \begin{bmatrix} 1 & 0 \\ 0 & 1 \end{bmatrix} \begin{bmatrix} s_{0,0} & s_{0,1} \\ s_{1,0} & s_{1,1} \end{bmatrix} = \begin{bmatrix} s_{0,0} & s_{0,1} \\ s_{1,0} & s_{1,1} \end{bmatrix}$$

The preceding matrix multiplication makes use of the following results in $\text{GF}(2^4)$: $9 + (2 \bullet 4) = 9 + 8 = 1$ and $(9 \bullet 4) + 2 = 2 + 2 = 0$. These operations can be verified using the arithmetic tables in Annex D.1 or by polynomial arithmetic.

The mix column function is the most difficult to visualize. Accordingly, we provide an additional perspective on it in Annex D.2.

D.3 KEY EXPANSION

For key expansion, the 16 bits of the initial key are grouped into a row of two 8-bit words. Figure D.5 shows the expansion into six words, by the calculation of four new words from the initial two words. The algorithm is as follows:

$$w_2 = w_0 \oplus g(w_1) = w_0 \oplus \text{RCON}(1) \oplus \text{SubNib}(\text{RotNib}(w_1))$$

$$w_3 = w_2 \oplus w_1$$

$$w_4 = w_2 \oplus g(w_3) = w_2 \oplus \text{RCON}(2) \oplus \text{SubNib}(\text{RotNib}(w_3))$$

$$w_5 = w_4 \oplus w_3$$

RCON is a round constant, defined as follows: $RC[i] = x^{i+2}$, so that $RC[1] = x^3 = 1000$ and $RC[2] = x^4 \bmod ((x^4 + x + 1) = x + 1 = 0011$. RC[i] forms the leftmost nibble of a byte, with the rightmost nibble being all zeros. Thus, $\text{RCON}(1) = 10000000$ and $\text{RCON}(2) = 00110000$.

For example, suppose the key is $2D55 = 0010\ 1101\ 0101\ 0101 = w_0w_1$. Then

$$\begin{aligned} w_2 &= 00101101 \oplus 10000000 \oplus \text{SubNib}(01010101) \\ &= 00101101 \oplus 10000000 \oplus 00010001 = 10111100 \end{aligned}$$

$$w_3 = 10111100 \oplus 01010101 = 11101001$$

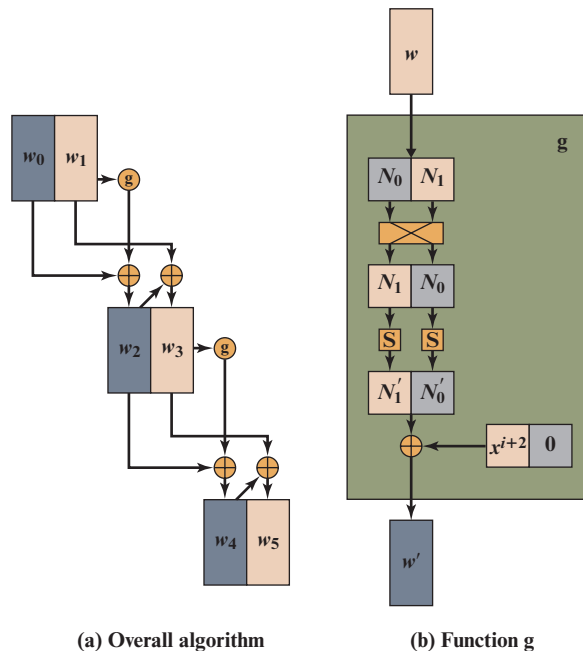

Figure D.5 S-AES Key Expansion

$$\begin{aligned} w_4 &= 10111100 \oplus 00110000 \oplus \text{SubNib}(10011110) \\ &= 10111100 \oplus 00110000 \oplus 00101111 = 10100011 \end{aligned}$$

$$w_5 = 10100011 \oplus 11101001 = 01001010$$

D.4 THE S-BOX

The S-box is constructed as follows:

1. Initialize the S-box with the nibble values in ascending sequence row by row. The first row contains the hexadecimal values (0, 1, 2, 3); the second row contains (4, 5, 6, 7); and so on. Thus, the value of the nibble at row i , column j is $4i + j$.
2. Treat each nibble as an element of the finite field $\text{GF}(2^4)$ modulo $x^4 + x + 1$. Each nibble $a_0a_1a_2a_3$ represents a polynomial of degree 3.
3. Map each byte in the S-box to its multiplicative inverse in the finite field $\text{GF}(2^4)$ modulo $x^4 + x + 1$; the value 0 is mapped to itself.
4. Consider that each byte in the S-box consists of 4 bits labeled (b_0, b_1, b_2, b_3) . Apply the following transformation to each bit of each byte in the S-box. The AES standard depicts this transformation in matrix form:

$$\begin{bmatrix} b'_0 \\ b'_1 \\ b'_2 \\ b'_3 \end{bmatrix} = \begin{bmatrix} 1 & 0 & 1 & 1 \\ 1 & 1 & 0 & 1 \\ 1 & 1 & 1 & 0 \\ 0 & 1 & 1 & 1 \end{bmatrix} \begin{bmatrix} b_0 \\ b_1 \\ b_2 \\ b_3 \end{bmatrix} \oplus \begin{bmatrix} 1 \\ 0 \\ 0 \\ 1 \end{bmatrix}$$

Here prime (') indicates that the variable is to be updated by the value on the right. Remember that addition and multiplication are being calculated modulo 2.

Table D.1a shows the resulting S-box. This is a nonlinear, invertible matrix. The inverse S-box is shown in Table D.1b.

D.5 S-AES STRUCTURE

We can now examine several aspects of interest concerning the structure of AES. First, note that the encryption and decryption algorithms begin and end with the add key function. Any other function, at the beginning or end, is easily reversible without knowledge of the key and so would add no security but just a processing overhead. Thus, there is a round 0 consisting of only the add key function.

The second point to note is that round 2 does not include the mix column function. The explanation for this in fact relates to a third observation, which is that although the decryption algorithm is the reverse of the encryption algorithm, as clearly seen in Figure D.1, it does not follow the same sequence of functions. Thus,

Encryption: $A_{K_2} \circ SR \circ NS \circ A_{K_1} \circ MC \circ SR \circ NS \circ A_{K_0}$

Decryption: $A_{K_0} \circ INS \circ ISR \circ IMC \circ A_{K_1} \circ INS \circ ISR \circ A_{K_2}$

From an implementation point of view, it would be desirable to have the decryption function follow the same function sequence as encryption. This allows the decryption algorithm to be implemented in the same way as the encryption algorithm, creating opportunities for efficiency.

Note that if we were able to interchange the second and third functions, the fourth and fifth functions, and the sixth and seventh functions in the decryption sequence, we would have the same structure as the encryption algorithm. Let's see if this is possible. First, consider the interchange of INS and ISR. Given a state N consisting of the nibbles (N_0, N_1, N_2, N_3) , the transformation $INS(ISR(N))$ proceeds as

$$\begin{pmatrix} N_0 & N_2 \\ N_1 & N_3 \end{pmatrix} \rightarrow \begin{pmatrix} N_0 & N_2 \\ N_3 & N_1 \end{pmatrix} \rightarrow \begin{pmatrix} IS[N_0] & IS[N_2] \\ IS[N_3] & IS[N_1] \end{pmatrix}$$

where IS refers to the inverse S-Box. Reversing the operations, the transformation $ISR(INS(N))$ proceeds as

$$\begin{pmatrix} N_0 & N_2 \\ N_1 & N_3 \end{pmatrix} \rightarrow \begin{pmatrix} IS[N_0] & IS[N_2] \\ IS[N_1] & IS[N_3] \end{pmatrix} \rightarrow \begin{pmatrix} IS[N_0] & IS[N_2] \\ IS[N_3] & IS[N_1] \end{pmatrix}$$

which is the same result. Thus, $INS(ISR(N)) = ISR(INS(N))$.

Now consider the operation of inverse mix column followed by add key: $IMC(A_{K_1}(N))$ where the round key K_1 consists of the nibbles $(k_{0,0}, k_{1,0}, k_{0,1}, k_{1,1})$. Then

$$\begin{aligned} & \begin{pmatrix} 9 & 2 \\ 2 & 9 \end{pmatrix} \left(\begin{pmatrix} k_{0,0} & k_{0,1} \\ k_{1,0} & k_{1,1} \end{pmatrix} \oplus \begin{pmatrix} N_0 & N_2 \\ N_1 & N_3 \end{pmatrix} \right) = \begin{pmatrix} 9 & 2 \\ 2 & 9 \end{pmatrix} \begin{pmatrix} k_{0,0} \oplus N_0 & k_{0,1} \oplus N_2 \\ k_{1,0} \oplus N_1 & k_{1,1} \oplus N_3 \end{pmatrix} \\ & = \begin{pmatrix} 9(k_{0,0} \oplus N_0) \oplus 2(k_{1,0} \oplus N_1) & 9(k_{0,1} \oplus N_2) \oplus 2(k_{1,1} \oplus N_3) \\ 2(k_{0,0} \oplus N_0) \oplus 9(k_{1,0} \oplus N_1) & 2(k_{0,1} \oplus N_2) \oplus 9(k_{1,1} \oplus N_3) \end{pmatrix} \\ & = \begin{pmatrix} (9k_{0,0} \oplus 2k_{1,0}) \oplus (9N_0 \oplus 2N_1) & (9k_{0,1} \oplus 2k_{1,1}) \oplus (9N_2 \oplus 2N_3) \\ (2k_{0,0} \oplus 9k_{1,0}) \oplus (2N_0 \oplus 9N_1) & (2k_{0,1} \oplus 9k_{1,1}) \oplus (2N_2 \oplus 9N_3) \end{pmatrix} \\ & = \begin{pmatrix} (9k_{0,0} \oplus 2k_{1,0}) & (9k_{0,1} \oplus 2k_{1,1}) \\ (2k_{0,0} \oplus 9k_{1,0}) & (2k_{0,1} \oplus 9k_{1,1}) \end{pmatrix} \oplus \begin{pmatrix} (9N_0 \oplus 2N_1) & (9N_2 \oplus 2N_3) \\ (2N_0 \oplus 9N_1) & (2N_2 \oplus 9N_3) \end{pmatrix} \\ & = \begin{pmatrix} 9 & 2 \\ 2 & 9 \end{pmatrix} \begin{pmatrix} k_{0,0} & k_{0,1} \\ k_{1,0} & k_{1,1} \end{pmatrix} \oplus \begin{pmatrix} 9 & 2 \\ 2 & 9 \end{pmatrix} \begin{pmatrix} N_0 & N_2 \\ N_1 & N_3 \end{pmatrix} \end{aligned}$$

All of these steps make use of the properties of finite field arithmetic. The result is that $IMC(A_{K_1}(N)) = IMC(K_1) \oplus IMC(N)$. Now let us define the inverse round key for round 1 to be $IMC(K_1)$ and the inverse add key operation IA_{K_1} to

be the bitwise XOR of the inverse round key with the state vector. Then we have $IMC(A_{K_1}(N)) = IA_{K_1}(IMC(N))$. As a result, we can write the following:

Encryption: $A_{K_2} \circ SR \circ NS \circ A_{K_1} \circ MC \circ SR \circ NS \circ A_{K_0}$

Decryption: $A_{K_0} \circ INS \circ ISR \circ IMC \circ A_{K_1} \circ INS \circ ISR \circ A_{K_2}$

Decryption: $A_{K_0} \circ ISR \circ INS \circ A_{IMC(K_1)} \circ IMC \circ ISR \circ INS \circ A_{K_2}$

Both encryption and decryption now follow the same sequence. Note that this derivation would not work as effectively if round 2 of the encryption algorithm included the MC function. In that case, we would have

Encryption: $A_{K_2} \circ MC \circ SR \circ NS \circ A_{K_1} \circ MC \circ SR \circ NS \circ A_{K_0}$

Decryption: $A_{K_0} \circ INS \circ ISR \circ IMC \circ A_{K_1} \circ INS \circ ISR \circ IMC \circ A_{K_2}$

There is now no way to interchange pairs of operations in the decryption algorithm so as to achieve the same structure as the encryption algorithm.

ANNEX D.1 ARITHMETIC IN $GF(2^4)$

Table D.2 shows the addition and multiplication tables in $GF(2^4)$ modulo $x^4 + x + 1$. For example, consider the product $(4 \bullet C) = (0100 \bullet 1100)$. In terms of polynomials, this is the product $[x^2 \times (x^3 + x^2)] \text{ mod } (x^4 + x + 1) = (x^5 + x^4) \text{ mod } (x^4 + x + 1)$. Because the degree of the polynomial to the right of the mod operator is greater than or equal to the modulus, a division is required to determine the remainder:

$$\begin{array}{r}
 x + 1 \\
 \hline
 x^4 + x + 1 \overline{) x^5 + x^4} \\
 \underline{x^5 + } \\
 x^4 + \\
 \underline{ x^4 + } \\
 x + 1 \\
 \underline{ x + 1} \\
 1
 \end{array}$$

In binary, the remainder is expressed as 0101, or 5 in hexadecimal. Thus $(4 \bullet C) = 5$, which agrees with the multiplication table in Table D.2.

Table D.2 Arithmetic in $GF(2^4)$ modulo $x^4 + x + 1$

(a) Addition

+	0	1	2	3	4	5	6	7	8	9	A	B	C	D	E	F
0	0	1	2	3	4	5	6	7	8	9	A	B	C	D	E	F
1	1	0	3	2	5	4	7	6	9	8	B	A	D	C	F	E
2	2	3	0	1	6	7	4	5	A	B	8	9	E	F	C	D
3	3	2	1	0	7	6	5	4	B	A	9	8	F	E	D	C
4	4	5	6	7	0	1	2	3	C	D	E	F	8	9	A	B

5	5	4	7	6	1	0	3	2	D	C	F	E	9	8	B	A
6	6	7	4	5	2	3	0	1	E	F	C	D	A	B	8	9
7	7	6	5	4	3	2	1	0	F	E	D	C	B	A	9	8
8	8	9	A	B	C	D	E	F	0	1	2	3	4	5	6	7
9	9	8	B	A	D	C	F	E	1	0	3	2	5	4	7	6
A	A	B	8	9	E	F	C	D	2	3	0	1	6	7	4	5
B	B	A	9	8	F	E	D	C	3	2	1	0	7	6	5	4
C	C	D	E	F	8	9	A	B	4	5	6	7	0	1	2	3
D	D	C	F	E	9	8	B	A	5	4	7	6	1	0	3	2
E	E	F	C	D	A	B	8	9	6	7	4	5	2	3	0	1
F	F	E	D	C	B	A	9	8	7	6	5	4	3	2	1	0

(b) Multiplication

	0	1	2	3	4	5	6	7	8	9	A	B	C	D	E	F
0	0	0	0	0	0	0	0	0	0	0	0	0	0	0	0	0
1	0	1	2	3	4	5	6	7	8	9	A	B	C	D	E	F
2	0	2	4	6	8	A	C	E	3	1	7	5	B	9	F	D
3	0	3	6	5	C	F	A	9	B	8	D	E	7	4	1	2
4	0	4	8	C	3	7	B	F	6	2	E	A	5	1	D	9
5	0	5	A	F	7	2	D	8	E	B	4	1	9	C	3	6
6	0	6	C	A	B	D	7	1	5	3	9	F	E	8	2	4
7	0	7	E	9	F	8	1	6	D	A	3	4	2	5	C	B
8	0	8	3	B	6	E	5	D	C	4	F	7	A	2	9	1
9	0	9	1	8	2	B	3	A	4	D	5	C	6	F	7	E
A	0	A	7	D	E	4	9	3	F	5	8	2	1	B	6	C
B	0	B	5	E	A	1	F	4	7	C	2	9	D	6	8	3
C	0	C	B	7	5	9	E	2	A	6	1	D	F	3	4	8
D	0	D	9	4	1	C	8	5	2	F	B	6	3	E	A	7
E	0	E	F	1	D	3	2	C	9	7	6	8	4	A	B	5
F	0	F	D	2	9	6	4	B	1	E	C	3	8	7	5	A

ANNEX D.2 THE MIX COLUMN FUNCTION

The mix column function operates on each column individually. Each nibble of a column is mapped into a new value that is a function of both nibbles in that column. The transformation is defined by the following matrix multiplication on **State** (Figure D.4).

$$\begin{bmatrix} 1 & 4 \\ 4 & 1 \end{bmatrix} \begin{bmatrix} s_{0,0} & s_{0,1} \\ s_{1,0} & s_{1,1} \end{bmatrix} = \begin{bmatrix} s'_{0,0} & s'_{0,1} \\ s'_{1,0} & s'_{1,1} \end{bmatrix}$$

We can recast this in terms of polynomials as follows. The value 1 corresponds to the polynomial 1 and the value 4 (binary 100) corresponds to the polynomial x^2 . Thus, we have

$$\begin{bmatrix} 1 & x^2 \\ x^2 & 1 \end{bmatrix} \begin{bmatrix} s_{0,0} & s_{0,1} \\ s_{1,0} & s_{1,1} \end{bmatrix} = \begin{bmatrix} s'_{0,0} & s'_{0,1} \\ s'_{1,0} & s'_{1,1} \end{bmatrix}$$

Remember that multiplication is performed modulo $(x^4 + x + 1)$. Using the polynomial formulation allows us to develop a simple explanation of the arithmetic involved. Referring back to the representation of the state matrix in Figure D.2a, we can recast the mix column multiplications as follows:

$$\begin{bmatrix} 1 & x^2 \\ x^2 & 1 \end{bmatrix} \begin{bmatrix} b_0x^3 + b_1x^2 + b_2x + b_3 & b_8x^3 + b_9x^2 + b_{10}x + b_{11} \\ b_4x^3 + b_5x^2 + b_6x + b_7 & b_{12}x^3 + b_{13}x^2 + b_{14}x + b_{15} \end{bmatrix}$$

Let's perform the multiplication of the first row of the left-hand matrix with the first column of the right-hand matrix to get the entry in the upper left-hand corner of the target matrix; that is, the polynomial value for $s'_{0,0}$. We have

$$\begin{aligned} s'_{0,0} &= (b_0x^3 + b_1x^2 + b_2x + b_3) + (x^2)(b_4x^3 + b_5x^2 + b_6x + b_7) \\ &= b_4x^5 + b_5x^4 + (b_0 \oplus b_6)x^3 + (b_1 \oplus b_7)x^2 + b_2x + b_3 \end{aligned}$$

It can easily be shown that

$$\begin{aligned} x^5 \bmod (x^4 + x + 1) &= (x^2 + x) \\ x^4 \bmod (x^4 + x + 1) &= (x + 1) \end{aligned}$$

The reader is invited to do the polynomial division to demonstrate these equalities. Using these results, we have

$$\begin{aligned} s'_{0,0} &= b_4(x^2 + x) + b_5(x + 1) + (b_0 \oplus b_6)x^3 + (b_1 \oplus b_7)x^2 + b_2x + b_3 \\ &= (b_0 \oplus b_6)x^3 + (b_1 \oplus b_4 \oplus b_7)x^2 + (b_2 \oplus b_4 \oplus b_5)x + (b_3 \oplus b_5) \end{aligned}$$

Expressed in terms of bits, the four bits of $s'_{0,0}$ are

$$s'_{0,0} = [(b_0 \oplus b_6), (b_1 \oplus b_4 \oplus b_7), (b_2 \oplus b_4 \oplus b_5), (b_3 \oplus b_5)]$$

Similarly, we can show that

$$\begin{aligned} s'_{1,0} &= [(b_2 \oplus b_4), (b_0 \oplus b_3 \oplus b_5), (b_0 \oplus b_1 \oplus b_6), (b_1 \oplus b_7)] \\ s'_{0,1} &= [(b_8 \oplus b_{14}), (b_9 \oplus b_{12} \oplus b_{15}), (b_{10} \oplus b_{12} \oplus b_{13}), (b_{11} \oplus b_{13})] \\ s'_{1,1} &= [(b_{10} \oplus b_{12}), (b_8 \oplus b_{11} \oplus b_{13}), (b_8 \oplus b_9 \oplus b_{14}), (b_9 \oplus b_{15})] \end{aligned}$$

APPENDIX E

MATHEMATICAL BASIS OF THE BIRTHDAY ATTACK

- E.1 Related Problem**
- E.2 The Birthday Paradox**
- E.3 Useful Inequality**
- E.4 The General Case of Duplications**
- E.5 Overlap Between Two Sets**

In this appendix, we derive the mathematical justification for the birthday attack. We begin with a related problem and then look at the problem from which the name “birthday attack” is derived.

E.1 RELATED PROBLEM

A general problem relating to hash functions is the following. Given a hash function H , with n possible outputs and a specific value $H(x)$, if H is applied to k random inputs, what must be the value of k so that the probability that at least one input y satisfies $H(y) = H(x)$ is 0.5?

For a single value of y , the probability that $H(y) = H(x)$ is just $1/n$. Conversely, the probability that $H(y) \neq H(x)$ is $[1 - (1/n)]$. If we generate k random values of y , then the probability that none of them match is just the product of the probabilities that each individual value does not match, or $[1 - (1/n)]^k$. Thus, the probability that there is at least one match is $1 - [1 - (1/n)]^k$.

The binomial theorem can be stated as

$$(1-a)^k = 1 - ka + \frac{k(k-1)}{2!}a^2 - \frac{k(k-1)(k-2)}{3!}a^3 \dots$$

For very small values of a , this can be approximated as $(1 - ka)$. Thus, the probability of at least one match is approximated as $1 - [1 - (1/n)]^k \approx 1 - [1 - (k/n)] = k/n$. For a probability of 0.5, we have $k = n/2$.

In particular, for an m -bit hash code, the number of possible codes is 2^m and the value of k that produces a probability of one-half is

$$k = 2^{(m-1)} \tag{E.1}$$

E.2 THE BIRTHDAY PARADOX

The birthday paradox is often presented in elementary probability courses to demonstrate that probability results are sometimes counterintuitive. The problem can be stated as follows: What is the minimum value of k such that the probability is greater than 0.5 that at least two people in a group of k people have the same birthday? Ignore February 29 and assume that each birthday is equally likely.

We can reason to the answer as follows. The probability that the birthdays of any two people are not alike is clearly $364/365$ (since there is only one chance in 365 that one person’s birthday will coincide with another’s). The probability that a third person’s birthday will differ from the other two is $363/365$; a fourth person’s, $362/365$; and so on, until we reach the 24th person ($342/365$). We thus obtain a series of 23 fractions which must be multiplied together to reach the probability that all 24 birthdays are different. The product is a fraction that reduces to about 0.507, or slightly better than $1/2$, for a coincidence among 23 people.

To derive this answer formally, let us define

$$P(n, k) = \Pr [\text{at least one duplicate in } k \text{ items, with each item able to take on one of } n \text{ equally likely values between 1 and } n]$$

Thus, we are looking for the smallest value of k such that $P(365, k) \geq 0.5$. It is easier first to derive the probability that there are no duplicates, which we designate as $Q(365, k)$. If $k > 365$, then it is impossible for all values to be different. So we assume $k \leq 365$. Now consider the number of different ways, N , that we can have k values with no duplicates. We may choose any of the 365 values for the first item, any of the remaining 364 numbers for the second item, and so on. Hence, the number of different ways is

$$N = 365 \times 364 \times \dots (365 - k + 1) = \frac{365!}{(365 - k)!} \quad (\text{E.2})$$

If we remove the restriction that there are no duplicates, then each item can be any of 365 values, and the total number of possibilities is 365^k . So the probability of no duplicates is simply the fraction of sets of values that have no duplicates out of all possible sets of values:

$$Q(365, k) = \frac{365! / (365 - k)!}{(365)^k} = \frac{365!}{(365 - k)! (365)^k}$$

and

$$P(365, k) = 1 - Q(365, k) = 1 - \frac{365!}{(365 - k)! (365)^k} \quad (\text{E.3})$$

This function is plotted in Figure E.1. The probabilities may seem surprisingly large to anyone who has not considered the problem before. Many people would guess that

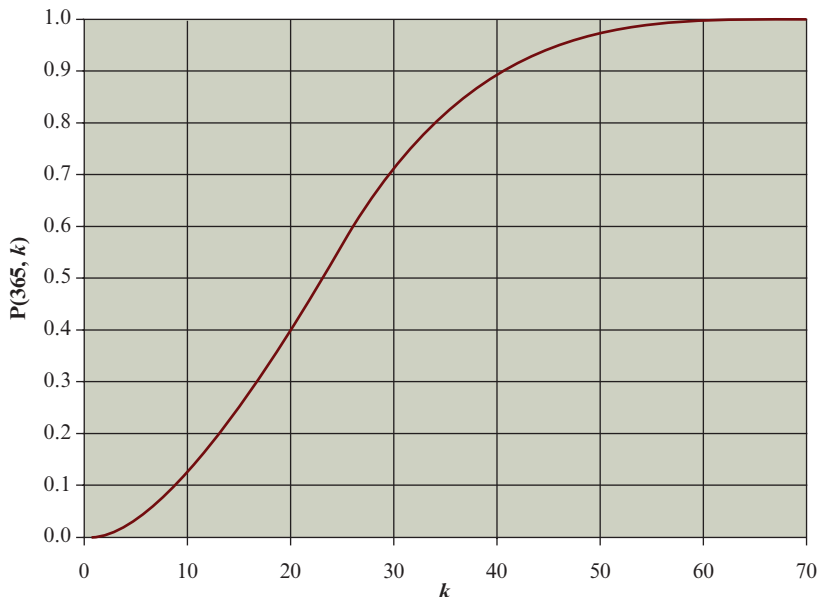

Figure E.1 The Birthday Paradox

to have a probability greater than 0.5 that there is at least one duplicate, the number of people in the group would have to be about 100. In fact, the number is 23, with $P(365, 23) = 0.5073$. For $k = 100$, the probability of at least one duplicate is 0.9999997.

Perhaps the reason that the result seems so surprising is that if you consider a particular person in a group, the probability that some other person in the group has the same birthday is small. But the probability that we are concerned with is the probability that *any* pair of people in the group has the same birthday. In a group of 23, there are $(23(23 - 1))/2 = 253$ different pairs of people. Hence the high probabilities.

E.3 USEFUL INEQUALITY

Before developing a generalization of the birthday problem, we derive an inequality that will be needed:

$$(1 - x) \leq e^{-x} \text{ for all } x \geq 0 \quad (\text{E.4})$$

Figure E.2 illustrates the inequality. To see that the inequality holds, note that the lower line is tangent to e^{-x} at $x = 0$. The slope of that line is just the derivative of e^{-x} at $x = 0$:

$$\begin{aligned} f(x) &= e^{-x} \\ f'(x) &= \frac{d}{dx} e^{-x} = -e^{-x} \\ f'(0) &= -1 \end{aligned}$$

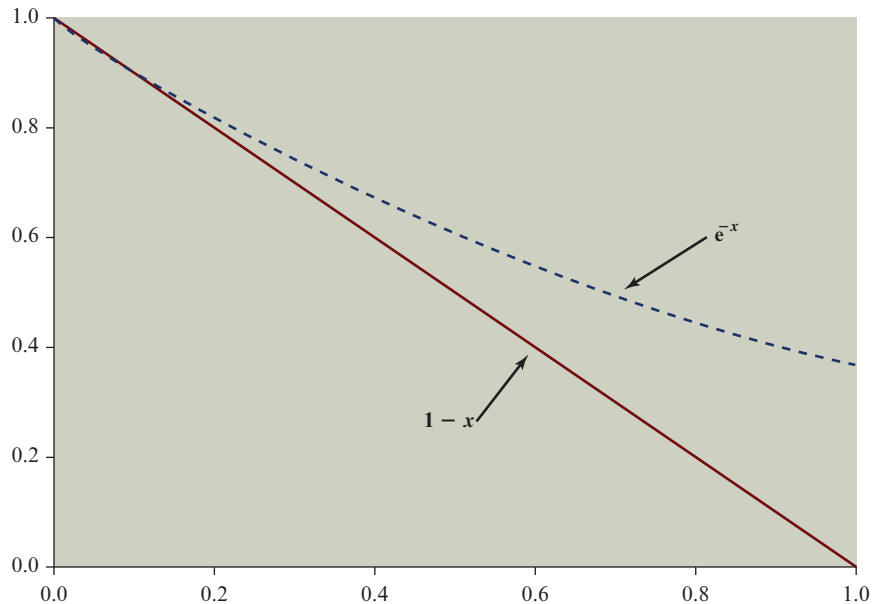

Figure E.2 A Useful Inequality

The tangent is a straight line of the form $ax + b$ with $a = -1$, and the tangent at $x = 0$ must equal $e^{-0} = 1$. Thus, the tangent is the function $(1 - x)$, confirming the inequality of Equation (11.4). Further, note that for small x , we have $(1 - x) \approx e^{-x}$.

E.4 THE GENERAL CASE OF DUPLICATIONS

The birthday problem can be generalized to the following problem. Given a random variable that is an integer with uniform distribution between 1 and n and a selection of k instances ($k \leq n$) of the random variable, what is the probability, $P(n, k)$, that there is at least one duplicate? The birthday problem is just the special case with $n = 365$. By the same reasoning as before, we have the following generalization of Equation (3):

$$P(n, k) = 1 - \frac{n!}{(n - k)!n^k} \quad (\text{E.5})$$

We can rewrite this as

$$\begin{aligned} P(n, k) &= 1 - \frac{n \times (n - 1) \times \dots \times (n - k + 1)}{n^k} \\ &= 1 - \left[\frac{n - 1}{n} \times \frac{n - 2}{n} \times \dots \times \frac{n - k + 1}{n} \right] \\ &= 1 - \left[\left(1 - \frac{1}{n}\right) \times \left(1 - \frac{2}{n}\right) \times \dots \times \left(1 - \frac{k - 1}{n}\right) \right] \end{aligned}$$

Using the inequality of Equation (4),

$$\begin{aligned} P(n, k) &> 1 - [(e^{-1/n}) \times (e^{-2/n}) \times \dots \times (e^{-(k-1)/n})] \\ &> 1 - e^{-[(1/n) + (2/n) + \dots + ((k-1)/n)]} \\ &> 1 - e^{-(k \times (k-1))/2n} \end{aligned}$$

Now let us pose the question: What value of k is required such that $P(n, k) > 0.5$? To satisfy the requirement, we have

$$\begin{aligned} 1/2 &= 1 - e^{-(k \times (k-1))/2n} \\ 2 &= e^{(k \times (k-1))/2n} \\ \ln 2 &= \frac{k \times (k - 1)}{2n} \end{aligned}$$

For large k , we can replace $k \times (k - 1)$ by k^2 , and we get

$$k = \sqrt{2(\ln 2)n} = 1.18\sqrt{n} \approx \sqrt{n} \quad (\text{E.6})$$

As a reality check, for $n = 365$, we get $k = 1.18 \times \sqrt{365} = 22.54$, which is very close to the correct answer of 23.

We can now state the basis of the birthday attack in the following terms. Suppose we have a function H , with 2^m possible outputs (i.e., an m -bit output). If H is applied to k random inputs, what must be the value of k so that there is the probability of at least one duplicate [i.e., $H(x) = H(y)$ for some inputs x, y]? Using the approximation in Equation (6),

$$k = \sqrt{2^m} = 2^{m/2} \quad (\text{E.7})$$

E.5 OVERLAP BETWEEN TWO SETS

There is a problem related to the general case of duplications that is also of relevance for our discussions. The problem is this: Given an integer random variable with uniform distribution between 1 and n and two sets of k instances ($k \leq n$) of the random variable, what is the probability, $R(n, k)$, that the two sets are not disjoint; that is, what is the probability that there is at least one value found in both sets?

Let us call the two sets X and Y , with elements $\{x_1, x_2, \dots, x_k\}$ and $\{y_1, y_2, \dots, y_k\}$, respectively. Given the value of x_1 , the probability that $y_1 = x_1$ is just $1/n$, and therefore the probability that y_1 does not match x_1 is $[1 - (1/n)]$. If we generate the k random values in Y , the probability that none of these values is equal to x_1 is $[1 - (1/n)]^k$. Thus, the probability that there is at least one match to x_1 is $1 - [1 - (1/n)]^k$.

To proceed, let us assume that all the elements of X are distinct. If n is large and if k is also large (e.g., on the order of \sqrt{n}), then this is a good approximation. In fact, there may be a few duplications, but most of the values will be distinct. With that assumption, we can make the following derivation:

$$\begin{aligned} \Pr[\text{no match in } Y \text{ to } x_1] &= \left(1 - \frac{1}{n}\right)^k \\ \Pr[\text{no match in } Y \text{ to } X] &= \left(\left(1 - \frac{1}{n}\right)^k\right)^k = \left(1 - \frac{1}{n}\right)^{k^2} \\ R(n, k) = \Pr[\text{at least one match in } Y \text{ to } X] &= 1 - \left(1 - \frac{1}{n}\right)^{k^2} \end{aligned}$$

Using the inequality of Equation (4),

$$\begin{aligned} R(n, k) &> 1 - (e^{-1/n})^{k^2} \\ R(n, k) &> 1 - (e^{-k^2/n}) \end{aligned}$$

Let us pose the question: What value of k is required such that $R(n, k) > 0.5$? To satisfy the requirement, we have

$$\begin{aligned} 1/2 &= 1 - (e^{-k^2/n}) \\ 2 &= e^{k^2/n} \\ \ln(2) &= \frac{k^2}{n} \\ k &= \sqrt{(\ln(2))n} = 0.83\sqrt{n} \approx \sqrt{n} \end{aligned} \quad (\text{E.8})$$

We can state this in terms related to birthday attacks as follows. Suppose we have a function H , with 2^m possible outputs (i.e., an m -bit output). Apply H to k random inputs to produce the set X and again to k additional random inputs to produce the set Y . What must be the value of k so that there is the probability of at least 0.5 that there is a match between the two sets (i.e., $H(x) = H(y)$ for some inputs $x \in X, y \in Y$)? Using the approximation in Equation (8):

$$k = \sqrt{2^m} = 2^{m/2}$$

GLOSSARY

access control The process of granting or denying specific requests: 1) for obtaining and using information and related information processing services; and 2) to enter specific physical facilities.

active attack An attempt to alter system resources or affect their operation

actuator A device that receives an electronic signal from a controller and responds by interacting with its environment to produce an effect on some parameter of a physical, chemical, or biological entity

Advanced Encryption Standard (AES) Specifies a U.S. government- approved cryptographic algorithm that can be used to protect electronic data. The AES algorithm is a symmetric block cipher that can encrypt (encipher) and decrypt (decipher) information. This standard specifies the Rijndael algorithm, a symmetric block cipher that can process data blocks of 128 bits, using cipher keys with lengths of 128, 192, and 256 bits.

anomaly detection An intrusion detection technique that searches for activity that is different from the normal behavior of system entities and system resources

application proxy A system that acts as a relay of application-level traffic

asymmetric encryption A form of cryptosystem in which encryption and decryption are performed using two different keys, one of which is referred to as the public key and one of which is referred to as the private key. Also known as public-key encryption.

attack Any kind of malicious activity that attempts to collect, disrupt, deny, degrade, or destroy information system resources or the information itself.

authentication The process of verifying an identity claimed by or for a system entity.

authentication exchange An exchange of information between two parties over a network that verifies the identity of a user, process, or device, often as a prerequisite to allowing access to resources in an information system

authentication server A centralized server whose function is to authenticate users to servers and servers to users

authenticator Additional information appended to a message to enable the receiver to verify that the message should be accepted as authentic. The authenticator may be functionally independent of the content of the message itself (e.g., a nonce or a source identifier) or it may be a function of the message contents (e.g., a hash value or a cryptographic checksum).

authenticity The property of being genuine and being able to be verified and trusted; confidence in the validity of a transmission, a message, or message originator.

availability The property of a system or a system resource being accessible and usable upon demand by an authorized system entity, according to performance specifications for the system; i.e., a system is available if it provides services according to the system design whenever users request them.

avalanche effect A characteristic of an encryption algorithm in which a small change in the plaintext or key gives rise to a large change in the ciphertext. For a hash code, the avalanche effect is a characteristic in which a small change in the message gives rise to a large change in the message digest.

backbone network A network that connects geographically dispersed fog networks as well as providing access to other networks that are not part of the enterprise network

backward unpredictability In a pseudorandom number stream, it is not feasible to determine the seed from knowledge of any generated values.

bacteria Program that consumes system resources by replicating itself.

base64 transfer encoding A binary-to-text encoding scheme that represent binary data in an ASCII string format by translating 6 bits of data into an 8-bit representation of a character.

big endian A byte format in which the most significant byte of a word is in the low-address (leftmost) byte position.

Bijection A one-to-one correspondence.

birthday attack This cryptanalytic attack attempts to find two values in the domain of a function that map to the same value in its range.

block chaining A procedure used during symmetric block encryption that makes an output block dependent not only on the current plaintext input block and key, but also on earlier input and/or output. The effect of block chaining is that two instances of the same plaintext input block will produce different ciphertext blocks, making cryptanalysis more difficult.

block cipher A symmetric encryption algorithm in which a block of plaintext bits (typically 64 or 128) is transformed as a whole into a ciphertext block of the same length.

block cipher mode of operation A technique for enhancing the effect of a cryptographic algorithm or adapting the algorithm for an application, such as applying a block cipher to a sequence of data blocks or a data stream

botnet A collection of systems, each of which has malware to launch attacks on other systems.

brute force attack A cryptanalysis technique or other kind of attack method involving an exhaustive procedure that tries all possibilities, one-by-one.

byte A sequence of 8 bits. Also referred to as an *octet*.

cipher An algorithm for encryption and decryption. A cipher replaces a piece of information (an element in plaintext) with another object with the intent to conceal meaning. Typically, the replacement rule is governed by a secret key.

ciphertext The output of an encryption algorithm; the encrypted form of a message or data.

ciphertext stealing A block cipher mode of operation technique in which the processing of the last block “steals” a temporary ciphertext of the penultimate block to complete the cipherblock.

circuit-level proxy A system that acts as a relay between two TCP connections.

cloud A collection of computing resources made available to a set of users over a network or the Internet.

cloud auditor A party that can conduct independent assessment of cloud services, information system operations, performance, and security of the cloud implementation

cloud broker An entity that manages the use, performance and delivery of cloud services, and negotiates relationships between CPs and cloud consumers

cloud carrier An intermediary that provides connectivity and transport of cloud services from CPs to cloud consumers

cloud service consumer (CSC) A person or organization that maintains a business relationship with, and uses service from, cloud providers

cloud service provider (CSP) A person, organization, or entity responsible for making a service available to interested parties

code An unvarying rule for replacing a piece of information (e.g., letter, word, phrase) with another object, not necessarily of the same sort. Generally, there is no intent to conceal meaning. Examples include the ASCII character code (each character is represented by 7 bits) and frequency-shift keying (each binary value is represented by a particular frequency).

commutative A binary operation in which changing the order of the operands does not change the result.

- composite number** An integer that is not prime
- compression function** A function used repeatedly in a hash algorithm.
- computationally secure** Secure because the time and/or cost of defeating the security are too high to be feasible.
- confidentiality** Preserving authorized restrictions on information access and disclosure, including means for protecting personal privacy and proprietary information. A loss of confidentiality is the unauthorized disclosure of information.
- confusion** A cryptographic technique that seeks to make the relationship between the statistics of the ciphertext and the value of the encryption key as complex as possible. This is achieved by the use of a complex scrambling algorithm that depends on the key and the input.
- constrained device** A device with limited volatile and nonvolatile memory, limited processing power, and a low data rate transceiver
- conventional encryption** Symmetric encryption.
- core** A network that connects geographically dispersed networks as well as providing access to other networks that are not part of the enterprise network
- covert channel** A communications channel that enables the transfer of information in a way unintended by the designers of the communications facility.
- cryptanalysis** The branch of cryptology dealing with the breaking of a cipher to recover information or forging encrypted information that will be accepted as authentic.
- cryptographic algorithm** An algorithm that uses the science of cryptography, including (a) encryption algorithms, (b) cryptographic hash algorithms, (c) digital signature algorithms, and (d) key-agreement algorithms.
- cryptographic checksum** An authenticator that is a cryptographic function of both the data to be authenticated and a secret key. Also referred to as a message authentication code (MAC).
- cryptographic hash function** An algorithm for which it is computationally infeasible (because no attack is significantly more efficient than brute force) to find either (a) a data object that maps to a pre-specified hash result (the one-way property) or (b) two data objects that map to the same hash result (the collision-free property).
- cryptography** The branch of cryptology dealing with the design of algorithms for encryption and decryption, intended to ensure the secrecy and/or authenticity of messages.
- cryptology** The study of secure communications, which encompasses both cryptography and cryptanalysis.
- cryptoperiod** Time span during which a specific cryptographic key is authorized for use for its defined purpose.
- cybersecurity** Prevention of damage to, protection of, and restoration of computers, electronic communications systems, electronic communications services, wire communication, and electronic communication, including information contained therein, to ensure its availability, integrity, authentication, confidentiality, and nonrepudiation.
- cryptosystem (cryptographic system)** A set of cryptographic algorithms together with the key management processes that support use of the algorithms in some application context.
- data authenticity** The property of a digital object that it is indeed what it claims to be.
- data confidentiality** The property that information is not made available or disclosed to unauthorized individuals, entities, or processes
- data integrity** The property that data has not been changed, destroyed, or lost in an unauthorized or accidental manner.

data origin authentication Provides for the corroboration of the source of a data unit. It does not provide protection against the duplication or modification of data units. This type of service supports applications like electronic mail, where there are no ongoing interactions between the communicating entities.

deciphering Decryption

decryption The translation of encrypted text or data (called ciphertext) into original text or data (called plaintext). Also called *deciphering*.

deeply embedded system A system that has a processor whose behavior is difficult to observe both by the programmer and the user. A deeply embedded system uses a microcontroller, is not programmable once the program logic for the device has been burned into ROM (read-only memory), and has no interaction with a user.

denial of service The prevention of authorized access to resources or the delaying of time-critical operations.

deskewing algorithm A technique to add additional randomness to a random bit stream.

detached signature A digital signature that may be stored and transmitted separately from the message it signs

differential cryptanalysis A technique in which chosen plaintexts with particular XOR difference patterns are encrypted. The difference patterns of the resulting ciphertext provide information that can be used to determine the encryption key.

diffusion A cryptographic technique that seeks to obscure the statistical structure of the plaintext by spreading out the influence of each individual plaintext digit over many ciphertext digits.

Digital Signature Algorithm (DSA) An authentication mechanism that enables the creator of a message to attach a code that acts as a signature. The signature is formed by taking the hash of the message and encrypting the message with the creator's private key. The signature guarantees the source and integrity of the message.

digram A two-letter sequence. In English and other languages, the relative frequency of various digrams in plaintext can be used in the cryptanalysis of some ciphers. Also called *digraph*.

direct digital signature Refers to a digital signature scheme that involves only the communicating parties (source, destination). It is assumed that the destination knows the public key of the source

discrete logarithm In the expression $b \equiv a^i \pmod{p}$, the exponent i is referred to as the discrete logarithm of the number b for the base $a \pmod{p}$.

discretionary access control An access control service that enforces a security policy based on the identity of system entities and their authorizations to access system resources. This service is termed "discretionary" because an entity might have access rights that permit the entity, by its own volition, to enable another entity to access some resource.

divisor One integer is said to be a divisor of another integer if there is no remainder on division.

eavesdropping Monitoring of, transmissions

edge In the context of IoT, the network of IoT devices.

electronic mail (email) A method of exchanging messages ("mail") between people using electronic devices.

ElGamal digital signature A digital signature algorithm used by a number of applications

elliptic curve Defined by an equation in two variables with coefficients

Elliptic Curve Digital Signature Algorithm (ECDSA) A public-key encryption algorithm based on elliptic curves.

elliptic curve cryptography The use of cryptographic algorithms based on elliptic curves.

embedded system Refers to the use of electronics and software within a product that has a specific function or set of functions, as opposed to a general-purpose computer, such as a laptop or desktop system. We can also define an embedded system as any device that includes a computer chip, but that is not a general-purpose workstation, desktop or laptop computer.

enciphering Encryption

encryption The conversion of plaintext or data into unintelligible form by means of a reversible translation, based on a translation table or algorithm. Also called enciphering.

end-to-end encryption Continuous protection of data that flows between two points in a network, effected by encrypting data when it leaves its source, keeping it encrypted while it passes through any intermediate computers (such as routers), and decrypting it only when it arrives at the intended final destination.

entropy source A source of random bits.

error-correction code A code in which each character or signal conforms to specific rules of construction so that deviations from these rules indicate the presence of an error and in which some or all of the detected errors can be corrected automatically.

false negative A test that returns negative when the actual result is positive.

false positive A test that returns positive when the actual result is negative.

federated identity management A system that involves the use of a common identity management scheme across multiple enterprises and numerous applications and supporting many thousands, even millions, of users.

Feistel cipher A classic, and still common, structure for symmetric encryption.

field A set of elements on which addition, subtraction, multiplication, and division are defined, and behave as the corresponding operations on rational and real numbers do. A field is thus a fundamental algebraic structure, which is widely used in algebra, number theory and many other areas of mathematics.

finite field A field with a finite number of elements

firewall A dedicated computer that interfaces with computers outside a network and has special security precautions built into it in order to protect sensitive files on computers within the network. It is used to service outside networks connections, especially the Internet and dial-in lines.

fog A collection of devices deployed physically near the edge of an IoT network; that is, near the sensors and other data-generating devices. Thus, some of the basic processing of large volumes of generated data is offloaded and outsourced from IoT application software located at the center

forward unpredictability In a pseudorandom number stream, if the seed is unknown, the next output bit in the sequence should be unpredictable in spite of any knowledge of previous bits in the sequence

greatest common divisor The greatest common divisor of two integers, a and b , is the largest positive integer that divides both a and b . One integer is said to divide another integer if there is no remainder on division.

group key A key used by multiple entities.

hash code Output of a hash function.

hash function A function that maps a variable-length data block or message into a fixed-length value called a hash code. The function is designed in such a way that, when protected, it provides an authenticator to the data or message. Also referred to as a message digest.

hash value Output of a hash function.

honeypot A decoy system designed to lure a potential attacker away from critical systems. A form of intrusion detection.

identity element An element of a set with respect to a binary operation on that set, which leaves other elements unchanged when combined with them

IEEE 802.11 A standard for wireless local area networks.

index Another name for discrete logarithm.

information security Preservation of confidentiality, integrity, and availability of information. In addition, other properties, such as authenticity), accountability, non-repudiation, and reliability can also be involved.

information technology (IT) Applied computer systems, both hardware and software, and often including networking and telecommunications, usually in the context of a business or other enterprise. Often the name of the part of an enterprise that deals with all things electronic.

initialization vector A random block of data that is used to begin the encryption of multiple blocks of plaintext, when a block-chaining encryption technique is used. The IV serves to foil known-plaintext attacks.

internet of things A networked collection of sensors and actuators owned by and operated on behalf of an organization.

intruder An individual who gains, or attempts to gain, unauthorized access to a computer system or to gain unauthorized privileges on that system.

intrusion detection system The detection of unauthorized access to a host system.

intrusion detection system A set of automated tools designed to detect unauthorized access to a host system.

intrusion prevention The prevention unauthorized access to a host system.

IP Security (IPsec) A security enhancement to IPv4 and IPv6

IPv4 The Internet Protocol version that was universally used until the advent of IPv6

IPv6 The Internet Protocol version intended to replace IPv4. Its most notable improvement over IPv4 is the use of longer address lengths.

irreversible mapping A transformation of data such that the original data cannot be recovered from the transformed data.

Kerberos The name given to Project Athena's code authentication service.

key distribution The distribution of encryption keys to two or more parties.

key distribution center A system that is authorized to transmit temporary session keys to principals. Each session key is transmitted in encrypted form using a master key that the key distribution center shares with the target principal.

key exchange A procedure whereby two communicating parties can cooperate to acquire a shared cryptographic key.

key expansion The generation of subkeys from a key

key management A mechanism or set of mechanisms for managing the creation, storage, distribution, and disposal of cryptographic keys.

key wrapping A method of securely exchanging a symmetric key to be shared by two parties, using a symmetric key already shared by those parties.

keyless algorithm A cryptographic algorithm, such as a hash algorithm, that does not use a key.

keystream A stream of bits used as the key for a stream encryption algorithm.

lightweight cryptographic algorithm A cryptographic algorithm designed for resource-constrained devices

- lightweight cryptography** A subfield of cryptography concerned with the development of cryptographic algorithms for resource-constrained devices
- little endian** A byte format in which the least significant byte of a word is in the low-address (left-most) byte position.
- logic bomb** Logic embedded in a computer program that checks for a certain set of conditions to be present on the system. When these conditions are met, it executes some function resulting in unauthorized actions.
- malware** Software that exploits vulnerabilities in a computing system to create an attack.
- mandatory access control** A means of restricting access to objects based on fixed security attributes assigned to users and to files and other objects. The controls are mandatory in the sense that they cannot be modified by users or their programs.
- man-in-the-middle attack** A form of active wiretapping attack in which the attacker intercepts and selectively modifies communicated data in order to masquerade as one or more of the entities involved in a communication.
- masquerade** A type of attack in which one system entity illegitimately poses as (assumes the identity of) another entity.
- master key** A long-lasting key that is used between a key distribution center and a principal for the purpose of encoding the transmission of session keys. Typically, the master keys are distributed by noncryptographic means. Also referred to as a *key-encrypting key*.
- media access control (MAC)** For broadcast networks, the method of determining which device has access to the transmission medium at any time.
- meet-in-the-middle attack** This is a cryptanalytic attack that attempts to find a value in each of the range and domain of the composition of two functions such that the forward mapping of one through the first function is the same as the inverse image of the other through the second function – quite literally meeting in the middle of the composed function.
- message authentication** A process used to verify the integrity of a message.
- message authentication code (MAC)** Cryptographic checksum.
- message digest** Hash function.
- microcontroller** A single chip that contains the processor, non-volatile memory for the program (ROM or flash), volatile memory for input and output (RAM), a clock, and an I/O control unit.
- misuse detection** An intrusion detection technique based on rules that specify system events, sequences of events, or observable properties of a system that are believed to be symptomatic of security incidents
- modular arithmetic** A kind of integer arithmetic that reduces all numbers to one of a fixed set $[0, \dots, n - 1]$ for some number n . Any integer outside this range is reduced to one in this range by taking the remainder after division by n .
- mode of operation** A technique for enhancing the effect of a cryptographic algorithm or adapting the algorithm for an application, such as applying a block cipher to a sequence of data blocks or a data stream.
- modulus** If a is an integer and n is a positive integer, we define $a \bmod n$ to be the remainder when a is divided by n . The integer n is called the modulus.
- monoalphabetic substitution cipher** A single cipher alphabet (mapping from plain alphabet to cipher alphabet) is used per message.
- multilevel security** A capability that enforces access control across multiple levels of classification of data.

multiple encryption Repeated use of an encryption function with different keys to produce a more complex mapping from plaintext to ciphertext.

network security Protection of networks and their service from unauthorized modification, destruction, or disclosure, and provision of assurance that the network performs its critical functions correctly and there are no harmful side effects.

nibble A sequence of four bits.

non-repudiation Assurance that the sender of information is provided with proof of delivery and the recipient is provided with proof of the sender's identity, so neither can later deny having processed the information.

nonce An identifier or number that is used only once.

notarization The use of a trusted third party to assure certain properties of a data exchange

one-time pad An encryption scheme in which the key length is equal to the message length, with each element (bit or character) of the key used to encrypt/decrypt each element of the message (e.g., by XOR). The key is randomly chosen and used only once, for a single message. If the key is secure, this scheme is impossible to break.

one-way function A function that is easily computed, but the calculation of its inverse is infeasible.

operational technology Machines/appliances with embedded IT built by non-IT companies, such as medical machinery, SCADA (supervisory control and data acquisition), process control, and kiosks, bought as appliances by enterprise OT people and primarily using wired connectivity

order The exponent to which a belongs (mod n)

OSI security architecture A management-oriented security standard that focuses on the OSI model and on networking and communications aspects of security.

pairwise keys Cryptographic keys used for communication between a pair of devices, typically between an STA and an AP. These keys form a hierarchy beginning with a master key from which other keys are derived dynamically and used for a limited period of time.

passive attack An attempt to learn or make use of information from the system that does not affect system resources.

password A secret data value, usually a character string, that is used as authentication information. A password is usually matched with a user identifier that is explicitly presented in the authentication process, but in some cases, the identity may be implicit.

peer entity authentication Provides for the corroboration of the identity of a peer entity in an association. Two entities are considered peers if they implement the same protocol in different systems; e.g., two TCP modules in two communicating systems.

permutation An ordered sequence of all the elements of a finite set of elements S , with each element appearing exactly once

plaintext The input to an encryption function or the output of a decryption function.

polyalphabetic substitution cipher The use of different monoalphabetic substitutions as one proceeds through the plaintext message.

post-quantum cryptographic algorithm A cryptographic algorithm designed using the principles of post-quantum cryptography.

post-quantum cryptography Concerned with the development of cryptographic algorithms that are secure against the potential development of quantum computers.

Post Office Protocol (POP3) An email protocol

prime number An integer $p > 1$ is a prime number if and only if its only divisors are ± 1 and $\pm p$.

- primitive root** If r and n are relatively prime integers with $n > 0$, and if $f(n)$ is the least positive exponent m such that $r^m \equiv 1 \pmod{n}$, then r is called a primitive root modulo n .
- privacy** The right of individuals to control or influence what information related to them may be collected and stored and by whom, and to whom that information may be disclosed
- private cloud** A cloud that is implemented within the internal IT environment of the organization
- private key** One of the two keys used in an asymmetric encryption system. For secure communication, the private key should only be known to its creator.
- product cipher** The execution of two or more simple ciphers in sequence in such a way that the final result or product is cryptographically stronger than any of the component ciphers
- pseudorandom function (PRF)** A function that produces a pseudorandom string of bits of some fixed length
- pseudorandom number generator** A function that deterministically produces a sequence of numbers that are apparently statistically random.
- public cloud** A cloud infrastructure made available to the general public or a large industry group and is owned by an organization selling cloud services
- public key** One of the two keys used in an asymmetric encryption system. The public key is made public and is to be used in conjunction with a corresponding private key.
- public-key certificate** Consists of a public key plus a User ID of the key owners with the whole block signed by a trusted third party. Typically, the third party is a certificate authority (CA) that is trusted by the user community, such as a government agency or a financial institution.
- public-key encryption** Asymmetric encryption.
- public-key infrastructure (PKI)** The set of hardware, software, people, policies, and procedures needed to create, manage, store, distribute, and revoke digital certificates based on asymmetric cryptography.
- quantum computing** A form of computing is based on the representation of information in a form analogous to the behavior of elementary particles in quantum physics
- quantum safety** Refers to cryptographic algorithms that are safe, or secure, against quantum computing algorithms
- relatively prime** Two numbers are relatively prime if they have no prime factors in common; that is, their only common divisor is 1.
- replay** An attack in which a service already authorized and completed is forged by another, duplicate request in an attempt to repeat authorized commands.
- replay attack** An attack in which a service already authorized and completed is forged by another “duplicate request” in an attempt to repeat authorized commands.
- residue** When the integer a is divided by the integer n , the remainder r is referred to as the residue. Equivalently, $r = a \pmod{n}$.
- residue class** All the integers that have the same remainder when divided by n form a residue class (\pmod{n}). Thus, for a given remainder r , the residue class (\pmod{n}) to which it belongs consists of the integers $r, r \pm n, r \pm 2n, \dots$
- reversible mapping** A transformation of data such that the original data can be recovered from the transformed data.
- round** An sub-algorithm in a cryptographic algorithm that is repeated multiple times.
- round function** The function performed by a round.

routing control Enables selection of particular physically or logically secure routes for certain data and allows routing changes, especially when a breach of security is suspected.

RSA algorithm A public-key encryption algorithm based on exponentiation in modular arithmetic. It is the only algorithm generally accepted as practical and secure for public-key encryption.

S-box A matrix structure that is used as part of some block cipher algorithms to perform substitution.

secret key The key used in a symmetric encryption system. Both participants must share the same key, and this key must remain secret to protect the communication.

security attack An assault on system security that derives from an intelligent threat; that is, an intelligent act that is a deliberate attempt (especially in the sense of a method or technique) to evade security services and violate the security policy of a system.

security mechanism A process (or a device incorporating such a process) that is designed to detect, prevent, or recover from a security attack.

security service A processing or communication service that enhances the security of the data processing systems and the information transfers of an organization. The services are intended to counter security attacks, and they make use of one or more security mechanisms to provide the service.

security threat A potential for violation of security, which exists when there is a circumstance, capability, action, or event that could breach security and cause harm. That is, a threat is a possible danger that might exploit a vulnerability.

seed The input to a pseudorandom number generator.

sensor A device that measures some parameter of a physical, chemical, or biological entity and delivers an electronic signal proportional to the observed characteristic, either in the form of an analog voltage level or a digital signal. In both cases, the sensor output is typically input to a microcontroller or other management element

session key A temporary encryption key used between two principals.

single-key algorithm A cryptographic algorithm that uses a single secret key.

single-key encryption Encryption that uses a single secret key.

Simple Mail Transfer Protocol (SMTP) An email protocol

skew Bias in a random or pseudorandom bit stream.

steganography Methods of hiding the existence of a message or other data. This is different than cryptography, which hides the meaning of a message but does not hide the message itself.

stream cipher A symmetric encryption algorithm in which ciphertext output is produced bit-by-bit or byte-by-byte from a stream of plaintext input.

subkey A key derived from the main key of an encryption algorithm, generally used for only one round.

substitution A basic mechanism of encryption in which one bit or block of data is substituted for another.

symmetric encryption A form of cryptosystem in which encryption and decryption are performed using the same key. Also known as *conventional encryption*.

system integrity Assures that a system performs its intended function in an unimpaired manner, free from deliberate or inadvertent unauthorized manipulation of the system.

threat A potential security harm to an asset.

timestamp A sequence of characters or encoded information identifying when a certain event occurred, usually giving date and time of day

timing attack An attack that depends on the running time of the decryption algorithm

- transceiver** A device that contains the electronics needed to transmit and receive data. Most IoT devices contain a wireless transceiver, capable of communication using Wi-Fi, ZigBee, or some other wireless scheme
- transport mode** A mode of operation of IPsec that provides protection to the payload of an IP packet.
- trapdoor** Secret undocumented entry point into a program used to grant access without normal methods of access authentication.
- trapdoor one-way function** A function that is easily computed, and the calculation of its inverse is infeasible unless certain privileged information is known.
- triple DES (3DES)** Multiple encryption using three instances of DES, with either two or three different keys
- Trojan horse** A computer program that appears to have a useful function, but also has a hidden and potentially malicious function that evades security mechanisms, sometimes by exploiting legitimate authorizations of a system entity that invokes the program.
- true random number generator** Produces bits non-deterministically using some physical source that has produces some sort of random output.
- trust** the willingness of a party to be vulnerable to the actions of another party based on the expectation that the other will perform a particular action important to the trustor, irrespective of the ability to monitor or control that other party
- trust relationship** A relationship between two different domains or areas of authority that makes it possible for users in one domain to be authenticated by a domain controller in the other domain.
- trusted system** A computer and operating system that can be verified to implement a given security policy.
- trustworthiness** A characteristic of an entity that reflects the degree to which that entity is deserving of trust
- tunnel mode** A mode of operation of IPsec that provides protection to both the payload and header of an IP packet
- tweakable block cipher** A cipher that has three inputs: a plaintext P , a symmetric key K , and a tweak T ; and produces a ciphertext output C .
- two-key algorithm** A cryptographic algorithm that uses a public key and a private key.
- user authentication** The process of verifying an identity claimed by or for a system entity.
- unconditionally secure** Secure even against an opponent with unlimited time and unlimited computing resources.
- unpredictability** The property of a stream of bits that future bits are not predictable from preceding bits.
- virtual private network** Consists of a set of computers that interconnect by means of a relatively unsecure network and that make use of encryption and special protocols to provide security.
- virus** Code embedded within a program that causes a copy of itself to be inserted in one or more other programs. In addition to propagation, the virus usually performs some unwanted function.
- Wi-Fi** A commercial specification of IEEE 802.11
- worm** Program that can replicate itself and send copies from computer to computer across network connections. Upon arrival, the worm may be activated to replicate and propagate again. In addition to propagation, the worm usually performs some unwanted function.
- zombie** A program that secretly takes over another Internet-attached computer and then uses that computer to launch attacks that are difficult to trace to the zombie's creator.

REFERENCES

ABBREVIATIONS

ACM Association for Computing Machinery
IBM International Business Machines Corporation
IEEE Institute of Electrical and Electronics Engineers
NIST National Institute of Standards and Technology

- ADAM94** Adams, C. “Simple and Effective Key Scheduling for Symmetric Ciphers.” *Proceedings, Workshop on Selected Areas of Cryptography, SAC’94*, 1994.
- AGRA04** Agrawal, M.; Kayal, N.; and Saxena, N. “PRIMES is in P.” *IIT Kanpur, Annals of Mathematics*, September 2004.
- AGRE11** Agren, M.; Hell, M.; Johansson, T.; and Meier, W. “A New Version of Grain-128 with Authentication.” *ECRYPT Workshop on Symmetric Encryption*, February 2011.
- ALFA13** AlFardan, N., et al. “On the Security of RC4 in TLS and WPA.” *USENIX Security Symposium*, July 2013.
- ANDR17** Androulaki, E. “Cryptography and Protocols in Hyperledger Fabric.” *Real-World Cryptography Conference*, 2017.
- AROR12** Arora, M. “How Secure is AES Against Brute-Force Attack?” *EE Times*, May 7, 2012.
- AUMA12** Aumasson, J., and Bernstein, D. “SipHash: A Fast Short-Input PRF.” *Progress in Cryptology – INDOCRYPT 2012*, 2012.
- BABB08** Babbage, S., et al. The eStream Portfolio. <http://www.ecrypt.eu.org/stream/portfolio.pdf>, April 15, 2008.
- BARD12** Bardou, R., et al. “Efficient Padding Oracle Attacks on Cryptographic Hardware.” INRIA, Rapport de recherche RR-7944. <http://hal.inria.fr/hal-00691958>, April 2012.
- BASU12** Basu, A. *Intel AES-NI Performance Testing over Full Disk Encryption*. Intel Corp. May 2012.
- BELL90** Bellare, S., and Merritt, M. “Limitations of the Kerberos Authentication System.” *Computer Communications Review*, October 1990.
- BELL94a** Bellare, M., and Rogaway, P. “Optimal Asymmetric Encryption—How to Encrypt with RSA.” *Proceedings, Eurocrypt ’94*, 1994.
- BELL94b** Bellare, S., and Cheswick, W. “Network Firewalls.” *IEEE Communications Magazine*, September 1994.
- BELL96a** Bellare, M.; Canetti, R.; and Krawczyk, H. “Keying Hash Functions for Message Authentication.” *Proceedings, CRYPTO ’96*, August 1996; published by Springer-Verlag. An expanded version is available at <http://www-cse.ucsd.edu/users/mihir>.
- BELL96b** Bellare, M.; Canetti, R.; and Krawczyk, H. “The HMAC Construction.” *CryptoBytes*, Spring 1996.
- BELL96c** Bellare, M., and Rogaway, P. “The Exact Security of Digital Signatures—How to Sign with RSA and Rabin.” *Advances in Cryptology – Eurocrypt ’96*, 1996.
- BELL98** Bellare, M., and Rogaway, P. “PSS: Provably Secure Encoding Method for Digital Signatures.” *Submission to IEEE P1363*, August 1998.

- BELL00** Bellare, M.; Kilian, J.; and Rogaway, P. “The Security of the Cipher Block Chaining Message Authentication Code.” *Journal of Computer and System Sciences*, December 2000.
- BELL09** Bellare, M., et al. “Format Preserving Encryption.” *Proceedings of SAC 2009 (Selected Areas in Cryptography)*, November 2009. Available at Cryptology ePrint Archive, Report 2004/094
- BELL10a** Bellare, M.; Rogaway, P.; and Spies, T. *The FFX Mode of Operation for Format-Preserving Encryption, Draft 1.1*. NIST, <http://csrc.nist.gov/groups/ST/toolkit/BCM/documents/proposedmodes/ffx/ffx-spec.pdf>, February, 2010.
- BELL10b** Bellare, M.; Rogaway, P.; and Spies, T. *Addendum to The FFX Mode of Operation for Format-Preserving Encryption: A parameter collection for enciphering strings of arbitrary radix and length*. NIST, <http://csrc.nist.gov/groups/ST/toolkit/BCM/documents/proposedmodes/ffx/ffx-spec2.pdf>, September 2010.
- BELL16** Bellare, S. “Attack Surfaces.” *IEEE Security & Privacy*, May-June, 2016.
- BENN97** Bennett, C., et al. “Strengths and Weaknesses of Quantum Computing.” *SIAM Journal on Computing*, October 1997.
- BERT07** Bertoni, G., et al. “Sponge Functions.” *Ecrypt Hash Workshop 2007*, May 2007.
- BERT11** Bertoni, G., et al. “Cryptographic Sponge Functions.” January 2011, <http://sponge.noekeon.org/>.
- BETH91** Beth, T.; Frisch, M.; and Simmons, G. eds. *Public-Key Cryptography: State of the Art and Future Directions*. New York: Springer-Verlag, 1991.
- BIRY04** Biryukov, A. *Block Ciphers and Stream Ciphers: The State of the Art*. Cryptology ePrint Archive, Report 2004/094, 2004.
- BIRY17** Biryukov, A., and Perrin, L. *State of the Art in Lightweight Symmetric Cryptography*. Cryptology ePrint Archive, Report 2017/511, 2017
- BLAC05** Black, J. “Authenticated Encryption.” *Encyclopedia of Cryptography and Security*, Springer, 2005.
- BLEI98** Bleichenbacher, D. “Chosen ciphertext attacks against protocols based on the RSA encryption standard PKCS #1,” *CRYPTO '98*, 1998.
- BLUM86** Blum, L.; Blum, M.; and Shub, M. “A Simple Unpredictable Pseudo-Random Number Generator.” *SIAM Journal on Computing*, No. 2, 1986.
- BOGA18** Bogatyy, I. “A Next-Generation Smart Contract and Decentralized Application Platform.” Ethereum White Paper. August 2018. <https://github.com/ethereum/wiki/wiki/White-Paper>
- BONE02** Boneh, D., and Shacham, H. “Fast Variants of RSA.” *CryptoBytes*, Winter/Spring 2002.
- BRIE10** Brier, E.; Peyrin, T.; and Stern, J. *BPS: a Format-Preserving Encryption Proposal*. NIST, <http://csrc.nist.gov/groups/ST/toolkit/BCM/documents/proposedmodes/bps/bps-spec.pdf>, April 2010.
- BRIG79** Bright, H., and Enison, R. “Quasi-Random Number Sequences from Long-Period TLP Generator with Remarks on Application to Cryptography.” *Computing Surveys*, December 1979.
- BRYA88** Bryant, W. *Designing an Authentication System: A Dialogue in Four Scenes*. Project Athena document, February 1988. Available at <http://web.mit.edu/kerberos/www/dialogue.html>
- BUTE15** Buterin, MV. “On Public and Private Blockchains.” *Ethereum Blog*, August 7, 2015, <https://blog.ethereum.org/2015/08/07/on-public-and-private-blockchains/>

- BUTI17** Butin, D. "Hash-Based Signatures: State of Play." *IEEE Security & Privacy*, July/August 2017.
- CACH16** Cachin, C. "Architecture of the Hyperledger Blockchain Fabric." *Workshop on Distributed Cryptocurrencies and Consensus Ledgers*, July 2016.
- CAKI10** Cakiroglu, M., et al. "Performance evaluation of scalable encryption algorithm for wireless sensor networks." *Scientific Research and Essays*, May 2010.
- CAMP92** Campbell, K., and Wiener, M. "Proof that DES is not a Group." *Proceedings, Crypto '92*, 1992; published by Springer-Verlag.
- CHOI08** Choi, M., et al. "Wireless Network Security: Vulnerabilities, Threats and Countermeasures." *International Journal of Multimedia and Ubiquitous Engineering*, July 2008.
- CONS17** Constantin, L. "The SHA-1 Hash Function is Now Completely Unsafe." *Computer-World*, February 23, 2017.
- COPP94** Coppersmith, D. "The Data Encryption Standard (DES) and Its Strength Against Attacks." *IBM Journal of Research and Development*, May 1994.
- CORM09** Cormen, T.; Leiserson, C.; Rivest, R.; and Stein, C. *Introduction to Algorithms*. Cambridge, MA: MIT Press, 2009.
- CRAN01** Crandall, R., and Pomerance, C. *Prime Numbers: A Computational Perspective*. New York: Springer-Verlag, 2001.
- CRYP17** CRYPTREC Lightweight Cryptography Working Group. *CRYPTREC Cryptographic Technology Guideline (Lightweight Cryptography)*. March 2017.
- CSA11** Cloud Security Alliance. *Security as a Service (SecaaS)*. CSA Report, 2011.
- CSA17** Cloud Security Alliance. *The Treacherous 12—Top Threats to Cloud Computing + Industry Insights*. CSA Report, October 2017.
- DAEM99** Daemen, J., and Rijmen, V. *AES Proposal: Rijndael, Version 2*. Submission to NIST, March 1999. <http://csrc.nist.gov/archive/aes/index.html>.
- DAMG89** Damgard, I. "A Design Principle for Hash Functions." *Proceedings, CRYPTO '89*, 1989; published by Springer-Verlag.
- DAVI89** Davies, D., and Price, W. *Security for Computer Networks*. New York: Wiley, 1989.
- DAWS96** Dawson, E., and Nielsen, L. "Automated Cryptanalysis of XOR Plaintext Strings." *Cryptologia*, April 1996.
- DENN81** Denning, D., and Sacco, G. "Timestamps in Key Distribution Protocols." *Communications of the ACM*, August 1981.
- DENN82** Denning, D. *Cryptography and Data Security*. Reading, MA: Addison-Wesley, 1982.
- DENN83** Denning, D. "Protecting Public Keys and Signature Keys." *Computer*, February 1983.
- DIFF76a** Diffie, W., and Hellman, M. "New Directions in Cryptography." *Proceedings of the AFIPS National Computer Conference*, June 1976.
- DIFF76b** Diffie, W., and Hellman, M. "Multiuser Cryptographic Techniques." *IEEE Transactions on Information Theory*, November 1976.
- DIFF77** Diffie, W., and Hellman, M. "Exhaustive Cryptanalysis of the NBS Data Encryption Standard." *Computer*, June 1977.
- DIFF79** Diffie, W., and Hellman, M. "Privacy and Authentication: An Introduction to Cryptography." *Proceedings of the IEEE*, March 1979.
- DIFF88** Diffie, W. "The First Ten Years of Public-Key Cryptography." *Proceedings of the IEEE*, May 1988.
- DIMI07** Dimitriadis, C. "Analyzing the Security of Internet Banking Authentication Mechanisms." *Information Systems Control Journal*, Vol. 3, 2007.

- DING17** Ding, J., and Petzoldt, A. “Current State of Multivariate Cryptography.” *IEEE Security & Privacy*, July/August 2017.
- DRUC18** Drucker, N.; Gueron, S.; and Krasnov, V. *Making AES great again: the forthcoming vectorized AES instruction*. Cryptology ePrint Archive, Report 2018/392, 2018
- EFF98** Electronic Frontier Foundation. *Cracking DES: Secrets of Encryption Research, Wiretap Politics, and Chip Design*. Sebastopol, CA: O’Reilly, 1998.
- ELGA84** Elgamal, T. “A Public Key Cryptosystem and a Signature Scheme Based on Discrete Logarithms.” *Proceedings, Crypto 84*, 1984.
- ELGA85** Elgamal, T. “A Public Key Cryptosystem and a Signature Scheme Based on Discrete Logarithms.” *IEEE Transactions on Information Theory*, July 1985.
- ENIS17** European Union Agency For Network And Information Security. *Baseline Security Recommendations for IoT*. November 2017. <https://www.enisa.europa.eu>
- ETSI14** European Telecommunications Standards Institute. *Quantum Safe Cryptography and Security; An introduction, benefits, enablers and challenges*. ETSI White Paper, 2014.
- FEIS73** Feistel, H. “Cryptography and Computer Privacy.” *Scientific American*, May 1973.
- FEIS75** Feistel, H.; Notz, W.; and Smith, J. “Some Cryptographic Techniques for Machine-to-Machine Data Communications.” *Proceedings of the IEEE*, November 1975.
- FERN99** Fernandes, A. “Elliptic Curve Cryptography.” *Dr. Dobb’s Journal*, December 1999.
- FORD95** Ford, W. “Advances in Public-Key Certificate Standards.” *ACM SIGSAC Review*, July 1995.
- FRAN07** Frankel, S., et al. *Establishing Wireless Robust Security Networks: A Guide to IEEE 802.11i*. NIST Special Publication SP 800-97, February 2007.
- GARD77** Gardner, M. “A New Kind of Cipher That Would Take Millions of Years to Break.” *Scientific American*, August 1977.
- GART17** Gartner Research. “What CIOs Should Tell the Board of Directors About Blockchain.” February 14, 2017. <https://www.gartner.com/doc/3606027/cios-tell-board-directors-blockchain>
- GEOR12** Georgiev, M., et al. “The Most Dangerous Code in the World: Validating SSL Certificates in Non-Browser Software.” *ACM Conference on Computer and Communications Security*, 2012.
- GONG92** Gong, L. “A Security Risk of Depending on Synchronized Clocks.” *Operating Systems Review*, January 1992.
- GONG93** Gong, L. “Variations on the Themes of Message Freshness and Replay.” *Proceedings, IEEE Computer Security Foundations Workshop*, June 1993.
- GOOD11** Goodin, D. “Hackers break SSL encryption used by millions of sites.” *The Register*, September 19, 2011.
- GOOD12** Goodin, D. “Crack in Internet’s foundation of trust allows HTTPS session hijacking.” *Ars Technica*, September 13, 2012.
- GREE18** Greenemeier, L. “How Close Are We—Really—to Building a Quantum Computer?” *Scientific American*, May 2018.
- GROV96** Grover, L. “A Fast Quantum Mechanical Algorithm for Database Search.” *ACM Symposium on Theory of Computing*, 1996.
- GUO11** Guo, J.; Peyrin, T.; and Poschmann, A. “The PHOTON Family of Lightweight Hash Functions.” 31st Annual International Cryptology Conference (CRYPTO 2011), 2011.
- GUTT06** Gutterman, Z.; Pinkas, B.; and Reinman, T. “Analysis of the Linux Random Number Generator.” *Proceedings, 2006 IEEE Symposium on Security and Privacy*, 2006.

- HART28** Hartley, R. "Transmission of Information." *Bell System Technical Journal*, July 1928.
- HELL79** Hellman, M. "The Mathematics of Public-Key Cryptography." *Scientific American*, August 1970.
- HELL06** Hell, M.; Johansson, T.; and Meier, W. "Grain—a stream cipher for constrained environments." *International Journal of Wireless and Mobile Computing*, vol. 2, no. 1, 2006.
- HERN06** Hernan, S.; Lambert, S.; Ostwald, T.; and Shostack, A. "Uncover Security Design Flaws Using The STRIDE Approach." *MSDN Magazine*, November 2006.
- HEVI99** Hevia, A., and Kiwi, M. "Strength of Two Data Encryption Standard Implementations Under Timing Attacks." *ACM Transactions on Information and System Security*, November 1999.
- HILT06** Hiltgen, A.; Kramp, T.; and Wiegold, T. "Secure Internet Banking Authentication." *IEEE Security and Privacy*, vol. 4, no. 2, 2006.
- HOWA03** Howard, M.; Pincus, J.; and Wing, J. "Measuring Relative Attack Surfaces." *Proceedings, Workshop on Advanced Developments in Software and Systems Security*, 2003.
- HUIT98** Huitema, C. *IPv6: The New Internet Protocol*. Upper Saddle River, NJ: Prentice Hall, 1998.
- IANS90** I'Anson, C., and Mitchell, C. "Security Defects in CCITT Recommendation X.509 - The Directory Authentication Framework." *Computer Communications Review*, April 1990.
- INTE14** Intel Corp. *Intel® Digital Random Number Generator (DRNG) Software Implementation Guide*. May 15, 2014. <https://software.intel.com/en-us/articles/intel-digital-random-number-generator-drng-software-implementation-guide>
- INTE18** Intel, Corp. Intel Architecture Instruction Set Extensions and Future Features Programming Reference. Ref. #319433-034, May 2018. <https://software.intel.com/sites/default/files/managed/c5/15/architecture-instruction-set-extensions-programming-reference.pdf>
- ISAC13** ISACA. *Responding to Targeted Cyberattacks*. 2008. www.isaca.org
- IWAT03** Iwata, T., and Kurosawa, K. "OMAC: One-Key CBC MAC." *Proceedings, Fast Software Encryption, FSE '03*, 2003.
- JAIN91** Jain, R. *The Art of Computer Systems Performance Analysis: Techniques for Experimental Design, Measurement, Simulation, and Modeling*. New York: Wiley, 1991.
- JAKO98** Jakobsson, M.; Shriver, E.; Hillyer, B.; and Juels, A. "A Practical Secure Physical Random Bit Generator." *Proceedings of The Fifth ACM Conference on Computer and Communications Security*, November 1998.
- JOHN05** Johnson, D. "Hash Functions and Pseudorandomness." *Proceedings, First NIST Cryptographic Hash Workshop*, 2005.
- JONS02** Jonsson, J. "On the Security of CTR + CBC-MAC." *Proceedings of Selected Areas in Cryptography – SAC 2002*, 2002.
- JUEN87** Jueneman, R. "Electronic Document Authentication." *IEEE Network Magazine*, April 1987.
- JURI97** Jurisic, A., and Menezes, A. "Elliptic Curves and Cryptography." *Dr. Dobb's Journal*, April 1997.
- KALI01** Kaliski, B. "RSA Digital Signatures." *Dr. Dobb's Journal*, May 2001.
- KALI95** Kaliski, B., and Robshaw, M. "The Secure Use of RSA." *CryptoBytes*, Autumn 1995.
- KALI96a** Kaliski, B., and Robshaw, M. "Multiple Encryption: Weighing Security and Performance." *Dr. Dobb's Journal*, January 1996.

- KALI96b** Kaliski, B. "Timing Attacks on Cryptosystems." *RSA Laboratories Bulletin*, January 1996. <http://www.rsasecurity.com/rsalabs>
- KEHN92** Kehne, A.; Schonwalder, J.; and Langendorfer, H. "A Nonce-Based Protocol for Multiple Authentications." *Operating Systems Review*, October 1992.
- KLEI10** Kleinjung, T., et al. "Factorization of a 768-bit RSA modulus." Listing 2010/006, *Cryptology ePrint Archive*, February 18, 2010.
- KNUD00** Knudson, L. "Block Chaining Modes of Operation." *NIST First Modes of Operation Workshop*, October 2000. <http://csrc.nist.gov/groups/ST/toolkit/BCM/workshops.html>
- KNUT98** Knuth, D. *The Art of Computer Programming, Volume 2: Seminumerical Algorithms*. Reading, MA: Addison-Wesley, 1998.
- KOBL94** Koblitz, N. *A Course in Number Theory and Cryptography*. New York: Springer-Verlag, 1994.
- KOCH96** Kocher, P. "Timing Attacks on Implementations of Diffie-Hellman, RSA, DSS, and Other Systems." *Proceedings, Crypto '96*, August 1996.
- KOHL89** Kohl, J. "The Use of Encryption in Kerberos for Network Authentication." *Proceedings, Crypto '89*, 1989; published by Springer-Verlag.
- KOHL94** Kohl, J.; Neuman, B.; and Ts'o, T. "The Evolution of the Kerberos Authentication Service." in Brazier, F., and Johansen, D. *Distributed Open Systems*. Los Alamitos, CA: IEEE Computer Society Press, 1994. Available at <http://web.mit.edu/kerberos/www/papers.html>
- KOHN78** Kohnfelder, L. *Towards a Practical Public Key Cryptosystem*. Bachelor's Thesis, M.I.T. 1978.
- KUMA97** Kumar, I. *Cryptology*. Laguna Hills, CA: Aegean Park Press, 1997.
- KUMA10** Kumar, K.; Salivahanan, S.; and Reddy, K. "Implementation of Low Power Scalable Encryption Algorithm." *International Journal of Computer Applications*, December 2010.
- KUMA11a** Kumar, K.; Reddy, K.; and Salivahanan, S. "Efficient Modular Adders for Scalable Encryption Algorithm." *International Journal of Computer Applications*, June 2011.
- KUMA11b** Kumar, M. "The Hacker's Choice Releases SSL DOS Tool." *The Hacker News*, October 24, 2011. <http://thehackernews.com/2011/10/hackers-choice-releases-ssl-ddos-tool.html#>
- LAI18** Lai, V. "A coffee-break introduction to time complexity of algorithms." July 9, 2018. <https://dev.to/vickylai/a-coffee-break-introduction-to-time-complexity-of-algorithms-160m>
- LAMP79** Lamport, L. "Constructing Digital Signatures from a One Way Function." *Computer Science Laboratory Technical Report CSL-98*, October 18, 1979.
- LAM92a** Lam, K., and Gollmann, D. "Freshness Assurance of Authentication Protocols." *Proceedings, ESORICS 92*, 1992; published by Springer-Verlag.
- LAM92b** Lam, K., and Beth, T. "Timely Authentication in Distributed Systems." *Proceedings, ESORICS 92*, 1992; published by Springer-Verlag.
- LAMP98** Lamport, L. "The Part-Time Parliament." *ACM Transactions on Computer Systems*, May 1998.
- LAUT17** Lauter, K. "Postquantum Opportunities: Lattices, Homomorphic Encryption, and Supersingular Isogeny Graphs." *IEEE Security & Privacy*, July/August 2017.
- LAW06** Law, Y.; Doumen, J.; and Hartel, P. "Survey and Benchmark of Block Ciphers for Wireless Sensor Networks." *ACM Transactions on Sensor Networks*, February 2006.

- LEHM51** Lehmer, D. "Mathematical Methods in Large-Scale Computing." *Proceedings, 2nd Symposium on Large-Scale Digital Calculating Machinery*, Cambridge: Harvard University Press, 1951.
- LEUT94** Leutwyler, K. "Superhack." *Scientific American*, July 1994.
- LEVE90** Leveque, W. *Elementary Theory of Numbers*. New York: Dover, 1990.
- LEVI12** Levis, P. "Experiences from a Decade of TinyOS Development." *10th USENIX Symposium on Operating Systems Design and Implementation*, 2012.
- LEWA00** Lewand, R. *Cryptological Mathematics*. Washington, DC: Mathematical Association of America, 2000.
- LEWI69** Lewis, P.; Goodman, A.; and Miller, J. "A Pseudo-Random Number Generator for the System/360." *IBM Systems Journal*, no. 2, 1969.
- LIDL94** Lidl, R., and Niederreiter, H. *Introduction to Finite Fields and Their Applications*. Cambridge: Cambridge University Press, 1994.
- LIPM00** Lipmaa, H.; Rogaway, P.; and Wagner, D. "CTR Mode Encryption." *NIST First Modes of Operation Workshop*, October 2000. <http://csrc.nist.gov/groups/ST/toolkit/BCM/workshops.html>
- LISK02** Liskov, M.; Rivest, R.; and Wagner, D. "Tweakable Block Ciphers." *Advances in Cryptology – CRYPTO 2002*, 2002.
- LUCK04** Luck, S. "Design Principles for Iterated Hash Functions." *Cryptology ePrint Archive*, Report 2004/253, 2004.
- LUK07** Luk, M., et al. "MiniSec: A Secure Sensor Network Communication Architecture." *International Conf. on Information Processing in Sensor Networks*, 2007.
- MA10** Ma, D., and Tsudik, G. "Security and Privacy in Emerging Wireless Networks." *IEEE Wireless Communications*, October 2010.
- MACE08** Mace, F.; Standaert, F.; and Quisquater, J. "FPGA Implementation(s) of a Scalable Encryption Algorithm." *IEEE Transactions on Very Large Scale Integration (VLSI) Systems*, February 2008.
- MANA11** Manadhata, P., and Wing, J. "An Attack Surface Metric." *IEEE Transactions on Software Engineering*, vol. 37, no. 3, 2011.
- MAUW05** Mauw, S., and Oostdijk, M. "Foundations of Attack Trees." *International Conference on Information Security and Cryptology*, 2005.
- MAYE95** Mayer, R.; Davis, J.; and Schoorman, D. "An Integrative Model of Organizational Trust." *Academy of Management Review*, July 1995.
- MCEL78** McEliece, R. "A Public-Key Cryptosystem Based on Algebraic Coding Theory." *Deep Space Network Progress Report*, Jet Propulsion Laboratory, California Institute of Technology, 1978.
- MCGR03** McGrew, D., and Viega, J. "Flexible and Efficient Message Authentication in Hardware and Software." 2003. Available at <http://citeseerx.ist.psu.edu/viewdoc/summary?doi=10.1.1.58.9422>
- MCGR04** McGrew, D., and Viega, J. "The Security and Performance of the Galois/Counter Mode (GCM) of Operation." *Proceedings, Indocrypt*, 2004.
- MECH14** Mechalis, J. *Intel® Digital Random Number Generator (DRNG) Software Implementation Guide*. Intel Developer Zone. May 15, 2014. <https://software.intel.com/en-us/articles/intel-digital-random-number-generator-drng-software-implementation-guide>
- MENE97** Menezes, A.; Oorschot, P.; and Vanstone, S. *Handbook of Applied Cryptography*. Boca Raton, FL: CRC Press, 1997. Available at: <http://cacr.uwaterloo.ca/hac/index.html>

- MERK79** Merkle, R. *Secrecy, Authentication, and Public Key Systems*. Ph.D. Thesis, Stanford University, June 1979.
- MERK81** Merkle, R., and Hellman, M. "On the Security of Multiple Encryption." *Communications of the ACM*, July 1981.
- MERK89** Merkle, R. "One Way Hash Functions and DES." *Proceedings, CRYPTO '89*, 1989; published by Springer-Verlag.
- MEYE88** Meyer, C., and Schilling, M. "Secure Program Load with Modification Detection Code." *Proceedings, SECURICOM 88*, 1988.
- MEYE13** Meyer, C.; Schwenk, J.; and Gortz, H. "Lessons Learned From Previous SSL/TLS Attacks A Brief Chronology Of Attacks And Weaknesses." *Cryptology ePrint Archive*, 2013.
- MILL75** Miller, G. "Riemann's Hypothesis and Tests for Primality." *Proceedings of the Seventh Annual ACM Symposium on the Theory of Computing*, May 1975.
- MILL88** Miller, S.; Neuman, B.; Schiller, J.; and Saltzer, J. "Kerberos Authentication and Authorization System." *Section E.2.1, Project Athena Technical Plan*, M.I.T. Project Athena, Cambridge, MA, 27 October 1988.
- MIRK04** Mirkovic, J., and Relher, P. "A Taxonomy of DDoS Attack and DDoS Defense Mechanisms." *ACM SIGCOMM Computer Communications Review*, April 2004.
- MITC90** Mitchell, C.; Walker, M.; and Rush, D. "CCITT/ISO Standards for Secure Message Handling." *IEEE Journal on Selected Areas in Communications*, May 1989.
- MOOR01** Moore, A.; Ellison, R.; and Linger, R. "Attack Modeling for Information Security and Survivability." *Carnegie-Mellon University Technical Note CMU/SEI-2001-TN-001*, March 2001.
- MUSA03** Musa, M.; Schaefer, E.; and Wedig, S. "A Simplified AES Algorithm and its Linear and Differential Cryptanalysis." *Cryptologia*, April 2004.
- MYER91** Myers, L. *Spycomm: Covert Communication Techniques of the Underground*. Boulder, CO: Paladin Press, 1991.
- NAS18** National Academy of Sciences. *Decrypting the Encryption Debate A Framework for Decision Makers*. Washington, DC: National Academies Press, 2018.
- NCAE13** National Centers of Academic Excellence in Information Assurance/Cyber Defense. *NCAE IA/CD Knowledge Units*. June 2013.
- NECH01** Nechvatal, J., et al. "Report on the Development of the Advanced Encryption Standard (AES)." *Journal of Research of the National Institute of Standards and Technology*, May-June 2001. <https://nvlpubs.nist.gov/nistpubs/jres/106/3/j63nec.pdf>
- NEED78** Needham, R., and Schroeder, M. "Using Encryption for Authentication in Large Networks of Computers." *Communications of the ACM*, December 1978.
- NEUM93a** Neuman, B., and Stubblebine, S. "A Note on the Use of Timestamps as Nonces." *Operating Systems Review*, April 1993.
- NEUM93b** Neuman, B. "Proxy-Based Authorization and Accounting for Distributed Systems." *Proceedings of the 13th International Conference on Distributed Computing Systems*, May 1993.
- NHTS14** National Highway Transportation Safety Agency. *Vehicle-to-Vehicle Communications: Readiness of V2V Technology for Application*. U. S. Department of Transportation, August 2014.
- NIST17** National Institute of Standards and Technology. "Profiles for the Lightweight Cryptography Standardization Process." *NIST Cybersecurity White Paper*, April 26, 2017.

- NIST18** National Institute of Standards and Technology. “Announcing Request for Comments on Lightweight Cryptography Requirements and Evaluation Criteria.” *Federal Register*, May 14, 2018.
- ODLY95** Odlyzko, A. “The Future of Integer Factorization.” *CryptoBytes*, Summer 1995.
- ORE67** Ore, O. *Invitation to Number Theory*. Washington, D.C.: The Mathematical Association of America, 1967.
- PARK88** Park, S., and Miller, K. “Random Number Generators: Good Ones are Hard to Find.” *Communications of the ACM*, October 1988.
- PARZ06** Parziale, L., et al. *TCP/IP Tutorial and Technical Overview*. ibm.com/redbooks, 2006.
- PAUL07** Paul, G., and Maitra, S. “Permutation after RC4 Key Scheduling Reveals the Secret Key.” *Selected Areas of Cryptography: SAC 2007, Lecture Notes on Computer Science*, Vol. 4876, pp 360-337, 2007.
- PELL10** Pellegrini, A.; Bertacco, V.; and Austin, A. “Fault-Based Attack of RSA Authentication.” *DATE '10 Proceedings of the Conference on Design, Automation and Test in Europe*, March 2010.
- POIN02** Pointcheval, D. “How to Encrypt Properly with RSA.” *CryptoBytes*, Winter/Spring 2002.
- POPE79** Popok, G., and Kline, C. “Encryption and Secure Computer Networks.” *ACM Computing Surveys*, December 1979.
- POPP17** Popper, N. “An Explanation of Initial Coin Offerings.” *New York Times*, October 27, 2017.
- PREN10** Preneel, B. “The First 30 Years of Cryptographic Hash Functions and the NIST SHA-3 Competition.” *CT-RSA'10 Proceedings of the 2010 International Conference on Topics in Cryptology*, 2010.
- RABI80** Rabin, M. “Probabilistic Algorithms for Primality Testing.” *Journal of Number Theory*, December 1980.
- RIBE96** Ribenboim, P. *The New Book of Prime Number Records*. New York: Springer-Verlag, 1996.
- RIVE78** Rivest, R.; Shamir, A.; and Adleman, L. “A Method for Obtaining Digital Signatures and Public Key Cryptosystems.” *Communications of the ACM*, February 1978.
- RIVE84** Rivest, R., and Shamir, A. “How to Expose an Eavesdropper.” *Communications of the ACM*, April 1984.
- ROBS95a** Robshaw, M. *Stream Ciphers*. RSA Laboratories Technical Report TR-701, July 1995. <http://www.rsasecurity.com/rsalabs>
- ROBS95b** Robshaw, M. *Block Ciphers*. RSA Laboratories Technical Report TR-601, August 1995. <http://www.rsasecurity.com/rsalabs>
- ROGA01** Rogaway, P.; Bellare, M.; Black, J.; and Krovetz, T. “OCB: A Block-Cipher Mode of Operation for Efficient Authenticated Encryption.” NIST Proposed Block Cipher Mode, August 2001. <https://csrc.nist.gov/Projects/Block-Cipher-Techniques/BCM/Modes-Development>
- ROGA03** Rogaway, P., and Wagner, A. *A Critique of CCM*. Cryptology ePrint Archive: Report 2003/070, April 2003.
- ROGA04a** Rogaway, P. “Efficient Instantiations of Tweakable Blockciphers and Refinements to Modes OCB and PMAC.” *Advances in Cryptology—Asiacrypt 2004. Lecture Notes in Computer Science*, Vol. 3329. Springer-Verlag, 2004.
- ROGA04b** Rogaway, P., and Shrimpton, T. “Cryptographic Hash-Function Basics: Definitions, Implications, and Separations for Preimage Resistance, Second-Preimage Resistance, and Collision Resistance.” *Fast Software Encryption*, 2004.

- ROGA10** Rogaway, P. “A Synopsis of Format-Preserving Encryption.” *Unpublished Manuscript*, March 2010. <http://web.cs.ucdavis.edu/~rogaway/papers>
- ROSA14** Rosado, T., and Bernardino, J. “An Overview of OpenStack Architecture.” *ACM IDEAS '14*, July 2014.
- SAAR12** Saarinen, M., and Engels, D. *A Do-It-All-Cipher for RFID: Design Requirements*. Cryptology ePrint Archive, Report 2012/317, 2012.
- SALT75** Saltzer, J., and Schroeder, M. “The Protection of Information in Computer Systems.” *Proceedings of the IEEE*, September 1975.
- SCHN91** Schneider, F., ed. *Trust in Cyberspace*. National Academy Press, 1999.
- SCHN96** Schneier, B. *Applied Cryptography*. New York: Wiley, 1996.
- SCHN14** Schneier, B. “The Internet of Things is Wildly Insecure—and Often Unpatchable.” *Wired*, January 6, 2014.
- SEAG08** Seagate Technology. *128-Bit Versus 256-Bit AES Encryption*. Seagate Technology Paper, 2008.
- SEFR12** Serfaoui, O.; Aissaoui, M.; and Eleuldj, M. “OpenStack: Toward an Open-Source Solution for Cloud Computing.” *International Journal of Computer Applications*, October 2012.
- SEGH12** Seghal, A., et al. “Management of Resource Constrained Devices in the Internet of Things.” *IEEE Communications Magazine*, December 2012.
- SEND17** Sendrier, N. “Code-Based Cryptography: State of the Art and Perspectives.” *IEEE Security & Privacy*, July/August 2017.
- SHAN49** Shannon, C. “Communication Theory of Secrecy Systems.” *Bell Systems Technical Journal*, no. 4, 1949.
- SHOR97** Shor, P. “Polynomial-Time Algorithms for Prime Factorization and Discrete Logarithms on a Quantum Computer.” *SIAM Journal of Computing*, October 1997.
- SIMM93** Simmons, G. “Cryptology.” *Encyclopaedia Britannica, Fifteenth Edition*, 1993.
- SING99** Singh, S. *The Code Book: The Science of Secrecy from Ancient Egypt to Quantum Cryptography*. New York: Anchor Books, 1999.
- SINK09** Sinkov, A., and Feil, T. *Elementary Cryptanalysis: A Mathematical Approach*. Washington, D.C.: The Mathematical Association of America, 2009.
- SMIT71** Smith, J. “The Design of Lucifer: A Cryptographic Device for Data Communications.” *IBM Research Report RC 3326*, April 15, 1971.
- SMIT15** Smith, A., and Whitcher, U. “Making a Hash of Things.” *Math Horizons*, November 2015.
- STAL18** Stallings, W., and Brown, L. *Computer Security: Principles and Practice*. Upper Saddle River, NJ: Pearson, 2018.
- STAL19** Stallings, W. *Effective Cybersecurity: Understanding and Using Standards and Best Practices*. Upper Saddle River, NJ: Pearson, 2019.
- STAN06** Standaert F.; Piret G.; Gershenfeld N.; and Quisquater, J. “SEA: A Scalable Encryption Algorithm for Small Embedded Applications.” *International Conference on Smart Card Research and Advanced Applications*, 2006.
- STEI88** Steiner, J.; Neuman, C.; and Schiller, J. “Kerberos: An Authentication Service for Open Networked Systems.” *Proceedings of the Winter 1988 USENIX Conference*, February 1988.
- STEV17** Stevens, M., et al. *The first collision for full SHA-1*. Cryptology ePrint Archive, Report 2017/190, 2017

- STIN06** Stinson, D. *Cryptography: Theory and Practice*. Boca Raton, FL: CRC Press, 2006.
- TAYL11** Taylor, G., and Cox, G. "Digital Randomness." *IEEE Spectrum*, September 2011.
- TIER15** Tierpoint. *With all Due Diligence*. Tierpoint White Paper, 2015. Tierpoint.com
- TIRI07** Tiri, K. "Side-Channel Attack Pitfalls." *Proceedings of the 44th Annual Design Automation Conference*, June 2007.
- TOBA07** Tobarra, L.; Cazorla, D.; Cuartero, F.; and Diaz, G. "Analysis of Security Protocol MiniSec for Wireless Sensor Networks." *The IV Congreso Iberoamericano de Seguridad Informatica (CIBSI'07)*, November 2007.
- TRAN18** Transparency Market Research. *Blockchain Technology Market to Emerge With Magnanimous Revenue: Key Facts Behind This Rise*. June 2018. <https://www.transparency-marketresearch.com/pressrelease/blockchain-technology-market.htm>
- TUCH79** Tuchman, W. "Hellman Presents No Shortcut Solutions to DES." *IEEE Spectrum*, July 1979.
- VANC11** Vance, J. *VAES3 Scheme for FFX*. NIST, <http://csrc.nist.gov/groups/ST/toolkit/BCM/documents/proposedmodes/ffx/ffx-ad-VAES3.pdf>, May 2011.
- VANO90** van Oorschot, P., and Wiener, M. "A Known-Plaintext Attack on Two-Key Triple Encryption." *Proceedings, EUROCRYPT '90*, 1990; published by Springer-Verlag.
- VANO94** van Oorschot, P., and Wiener, M. "Parallel Collision Search with Application to Hash Functions and Discrete Logarithms." *Proceedings, Second ACM Conference on Computer and Communications Security*, 1994.
- VOYD83** Voydock, V., and Kent., S. "Security Mechanisms in High-Level Network Protocols." *Computing Surveys*, June 1983.
- WALK05** Walker, J. "802.11 Security Series. Part III: AES-based Encapsulations of 802.11 Data." Platform Networking Group, Intel Corporation, 2005.
- WAYN09** Wayner, P. *Disappearing Cryptography*. Boston and Burlington, MA: Morgan Kaufmann, 2009.
- WEBS86** Webster, A., and Tavares, S. "On the Design of S-Boxes." *Proceedings, Crypto '85*, 1985; published by Springer-Verlag.
- WIEN90** Wiener, M. "Cryptanalysis of Short RSA Secret Exponents." *IEEE Transactions on Information Theory*, vol. 36, no. 3, 1990.
- WOO92a** Woo, T., and Lam, S. "Authentication for Distributed Systems." *Computer*, January 1992.
- WOO92b** Woo, T., and Lam, S. "'Authentication' Revisited." *Computer*, April 1992.
- XU16** Xu, X., et al. "The Blockchain as a Software Connector." *2016 13th Working IEEE/IFIP Conference on Software Architecture*, April 2016.
- YUVA79** Yuval, G. "How to Swindle Rabin." *Cryptologia*, July 1979.

INDEX

A

Abelian groups, 138–139, 323–324
 associative, 323
 closure, 323
 commutative, 323
 elliptic curve, 324
 identity element, 323
 inverse element, 323
Ability, 38
Absorbing phase, 364, 365
Access control, 31, 33, 576, 581, 586
Access point (AP), 568, 569, 575, 577
Accidental association, 568
Account/service hijacking, 717
Accountability, 25
Active attacks, 29–30
 data modification, 29
 denial of service, 29
 masquerade, 29
 replay, 29
Actuator, 730
Ad hoc networks, 568
Adaptive chosen message attack, 419
Adaptive Proportion Test, 277
Addition, 139, 140, 158
 algebraic description of, 326
 geometric description of, 324–326
Additive inverse, 54
AddRoundKey, 171, 172, 174, 192–194
 forward add round key
 transformation, 183
 inputs for single AES round, 184
 inverse add round key
 transformation, 183
Administrative management domain
 (ADMD), 600, 631
Advanced Encryption Standard (AES),
 113, 123, 136, 154, 166
 AddRoundKey and InvMixColumns,
 192–193
 avalanche effect, 188–191
 byte-level operations, 174
 data structures, 170
 detailed structure, 171–173
 AddRoundKey, 171
 MixColumns, 171
 ShiftRows, 171
 substitute bytes, 171
 encryption
 and decryption, 172
 process, 169
 round, 173
 equivalent inverse cipher, 191–193
 example, 187–191
 vs. FPE, 225
 general structure, 168–171
 State, 168
 implementation, 191–195
 8-bit processor, 193–194
 32-bit processor, 194–195
 inputs for, 184
 InvShiftRows and InvSubByte, 192
 key expansion, 184–186
 parameters, 170

 row and column operations, 180
 State array, 168
 transformation functions (*See*
 Transformation functions, AES)
Advanced persistent threat (APT),
 717–720
 encrypt data, 719
 enterprise reconnaissance, 719
 exfiltrate data, 720
 foothold, 719
 initial attack, 719
 maintaining, 720
 moving to new systems, 719
 persistence, 719
 privileges, 719
 research, 719
AEAD. *See* Authenticated encryption
 with additional data (AEAD)
Agricultural sensors, 443
AH. *See* Authentication Header (AH)
Alert protocol, 541
Algorithm
 decryption, 289
 design, 251–252
 cryptographic algorithms, 251–252
 hash functions, 252
 message authentication codes, 252
 purpose-built algorithms, 251
 symmetric block ciphers, 252
 encryption, 288
 negotiation, 556
Analyzers, 682
Anomaly detection, 683–684
 false negatives, 684
 false positives, 684
 profile based, 685
 strategies, 685
 threshold, 685
Anti-replay service, 651–652
 receiver, 652
 replay attack, 651–652
 sender, 652
AP. *See* Access point (AP)
Application-level gateway, 679–680
Application proxy. *See* Application-level
 gateway
Arbitrary reversible substitution
 cipher, 116
Associative group, 137, 323
Associative laws, 54
Associativity of multiplication, 139
Asymmetric cryptographic
 algorithms, 456
Asymmetric encryption, 35–36
 algorithms, 35
 keys, 290
 PKI, 287
 public key certificate, 287
 public key cryptographic
 algorithm, 287
 terminology related to, 287
Attack, 27
Attack that consumes data transmission
 resources, 692

Authenticated encryption (AE), 399–405
 architecture strategies, 448–449
 block ciphers, 449–451
 CMAC, 399–402
 GCM, 402–405
 authentication and encryption
 functions, 403
 message authentication code, 404
 stream ciphers, 451
Authenticated encryption with
 additional data (AEAD), 445
Authentication
 data origin, 31
 ESP, 658
 exchange, 33
 Grain-128a, 272
 IEEE 802.11i wireless LAN
 security, 586–588
 IKE key determination, 663
 payload, 667
 peer entity, 31
 public-key cryptography, 292, 293
 S/MIME, 610–613
 STRIDE threat model, 714
Authentication Header (AH), 644, 646
Authentication service exchange, 522
Authenticator, 292, 380
Authenticity, 25
Authenticity-related threats, 607
Authority key identifier, 492
Authorization security controls, 715
Autokey system, 102
Automated key management, 661
Automobiles, 444
Availability, 24, 714
Availability service, 32–33
Availability-related threats, 607
Avalanche effect, 188–191
 DES, 125–127
B
Backbone network, 732
Backward unpredictability, 250
Barrier security, 574
Base64 transfer encoding, 606
Basic service set (BSS), 575, 577, 578
Benevolence, 38
BIC. *See* Bit independence
 criterion (BIC)
Big-endian format, 355
Bijection, 69
Binary curve, 326
Binary operator, 51
Binary operator mod, 81
Birthday attack. *See* Mathematical
 basis of birthday attack
Birthday paradox, 349, 789–791
Bit independence criterion (BIC), 130
56-bit keys, 128
Bit length, 232
8-bit processor, 193–194
32-bit processor, 194–195
Bitrate, 362, 363

- Blinding, 307
 - Block cipher, 113–114
 - advantage of, 261–262
 - authenticated encryption, 449–451
 - CBC mode, 210–212
 - CFB mode, 212–214
 - CTR mode, 212, 216–218
 - encryption, 212
 - OFB mode, 212, 214–216
 - s-bit, 213
 - segments, 212
 - CTR mode, 212, 216–218
 - advantages of, 217–218
 - hardware efficiency, 217
 - preprocessing, 218
 - provable security, 218
 - random access, 218
 - simplicity, 218
 - software efficiency, 218
 - design principles, 129–131
 - BIC, 130
 - design of function F, 130
 - key schedule algorithm, 131
 - number of rounds, 130
 - SAC, 130
 - double DES, 202–204
 - ECB, 207–210
 - diffusion, 210
 - error propagation, 209
 - error recovery, 209
 - modes of operation, 207
 - overhead, 209
 - security, 210
 - FPE, 225–239
 - AES vs., 225
 - difficulties in designing an, 226–227
 - Feistel structure for, 227–232
 - motivation, 225–226
 - NIST methods for, 233–239
 - notation in, 230
 - parameters in, 230
 - MAC on, 396–398
 - CMAC, 397–398
 - DAA, 396–397
 - modes of operation, 208
 - multiple encryption, 202–207
 - OFB mode, 212, 214–216
 - PRNGs, 255–260
 - mechanisms, 256
 - NIST CTR_DRBG, 257–260
 - processes, 87
 - symmetric, 252
 - symmetric encryption algorithms, 35
 - triple DES
 - known-plaintext attack on, 206
 - with three keys, 207
 - with two keys, 204–207
 - TRNG, 275
 - tweakable, 219–220
 - XTS-AES mode, 218–225
 - ciphertext-stealing technique, 223
 - definition, 224
 - feedback characteristic of modes of operation, 219
 - operation on sector, 223–225
 - operation on single block, 221–223
 - storage encryption requirements, 220–221
 - tweakable block ciphers, 219–220
 - Block size, 120
 - Blum Blum Shub (BBS) generator, 254–255
 - Botnet, 687
 - Bring-your-own-device (BYOD) policy, 572
 - Broad network access, 702
 - Brute-force approach, 247
 - Brute-force attacks, 87, 89, 249, 302, 348–351, 459
 - birthday paradox, 349
 - collision resistant attacks, 349–351
 - cryptanalysis, 351–352
 - MAC, 390–391
 - preimage and second preimage attacks, 349
 - BSS. *See* Basic service set (BSS)
 - Business continuity and disaster recovery, 723
 - BYOD policy. *See* Bring-your-own-device (BYOD) policy
- C**
- Caesar cipher, 90–92, 100–101
 - Canonical form, 606–567
 - Capacity, 364
 - CBC mode. *See* Cipher block chaining (CBC) mode
 - CBC-MAC/CMAC, 278–279
 - CCA. *See* Chosen ciphertext attack (CCA)
 - CCMP. *See* Counter Mode-CBC MAC Protocol (CCMP)
 - Certificate Association Data, 624
 - Certificate payload, 667
 - Certificate policies, 493
 - Certificate Request payload, 667
 - Certification authority (CA)
 - forward certificates, 490
 - reverse certificates, 490
 - CFB mode. *See* Cipher feedback (CFB) mode
 - Change Cipher Spec protocol, 540
 - Character strings, 229–231
 - Chi step function, 369, 372–373
 - Chinese remainder theorem (CRT), 69–71, 302
 - bijection, 69
 - first assertion, 69–70
 - second assertion, 70
 - Chip area, 442
 - Chosen ciphertext attack (CCA), 88, 304, 308–309
 - Chosen text attack, 88
 - Chosen-plaintext approach, 205
 - Chosen-plaintext attack, 88
 - CIA triad, 24
 - accountability, 25
 - authenticity, 24
 - availability, 24
 - confidentiality, 24
 - integrity, 24
 - Cipher, 84
 - block (*See* Block cipher)
 - design principles, 129–131
 - design of function F, 130
 - key schedule algorithm, 131
 - number of rounds, 130
 - SAC, 130
 - Cipher block chaining (CBC) mode, 210–212, 345
 - Cipher feedback (CFB) mode, 212–214
 - CTR mode, 212, 216–218
 - encryption, 212
 - OFB mode, 212, 214–216
 - s-bit, 213
 - segments, 212
 - Cipher spec, 538
 - Cipher-Based Message Authentication Code (CMAC), 397–402
 - Ciphertext, 84, 85, 289
 - plaintext transforming to, 87
 - Ciphertext only attack, 88
 - Ciphertext-stealing technique, 223
 - Circuit-level gateway, 680
 - Circuit-level proxy. *See* Circuit-level gateway
 - Claimant, 503
 - Classical encryption, 84–106
 - Client write key, 538
 - Client write MAC secret, 538
 - Client/server authentication exchange, 523
 - Closure, 137
 - under multiplication, 139
 - Closure group, 323
 - Cloud auditor, 708, 709, 710
 - Cloud broker, 708, 710
 - service aggregation, 710
 - service arbitrage, 710
 - service intermediation, 710
 - Cloud carrier, 709, 710
 - Cloud computing, 701–711
 - characteristics of, 701–703
 - broad network access, 702
 - measured service, 702
 - on-demand self-service, 702
 - rapid elasticity, 702
 - resource pooling, 702–703
 - definition, 701
 - deployment models
 - community cloud, 706
 - comparison of, 708
 - hybrid cloud, 706–708
 - private cloud, 706, 707
 - public cloud, 704–705
 - elements, 701–703
 - elements, 701–703
 - broad network access, 702
 - measured service, 702
 - on-demand self-service, 702
 - rapid elasticity, 702
 - resource pooling, 702–703
 - reference architecture, 708–711
 - cloud auditor, 708, 709, 710
 - cloud broker, 709, 710
 - cloud carrier, 709, 710
 - cloud service customer (CSC), 708
 - cloud service provider (CSP), 708
 - roles and responsibilities, 708–711
 - service models
 - IaaS, 703–704
 - PaaS, 703
 - SaaS, 703
 - separation of responsibilities in, 704
 - Cloud network, 732
 - Cloud security
 - computing, 701–711
 - deployment models, 704–708
 - elements, 701–703

- reference architecture, 708–711
- service models, 703–704
- concepts, 711–713
- guidelines, 712–713
- open-source module, 724–725
- privacy issues and recommendations, 712–713
- risk and countermeasures, 713–721
 - abuse and nefarious use of, 721
 - account hijacking, 717
 - advanced persistent threats, 717–720
 - data breaches, 715–716
 - data loss, 720
 - denial-of-service, 721
 - insecure APIs, 716
 - insufficient due diligence, 720
 - malicious insiders, 717
 - shared technology
 - vulnerabilities, 721
 - STRIDE threat model, 714–715
 - system vulnerabilities, 717
 - weak identity, credential, and access management, 716
- as service, 721–724 (*See also* SecaaS)
 - business continuity and disaster recovery, 723
 - DLP, 723
 - elements, 722
 - email security, 723
 - encryption, 723
 - IAM, 723
 - intrusion management, 723
 - network security, 724
 - security assessments, 723
 - SIEM, 723
 - web security, 723
- Cloud service customer (CSC), 708
- Cloud service provider (CSP), 708
- CMAC. *See* Cipher-Based Message Authentication Code (CMAC)
- Coefficient set, 145
- Codeword, 466
- Collision, 346
- Collision resistant, 347
 - attacks, 349–351
 - brute-force attacks, 349–351
- Communications security, 36, 737
- Communications transmission rate, 442
- Community cloud, 706
- Commutative, 53, 138
- Commutative group, 323
- Commutative laws, 54
- Commutative ring, 139
- Commutativity of multiplication, 139
- Composite number, 67
- Composition, 367
- Comprehensive email security, 607–609
- Compression
 - function, 351
 - method, 538
 - S/MIME, 613
- Computation resistance, MAC, 396
- Computational aspects, 299–304
- Computational secrecy, 755
- Computationally secure encryption scheme, 89
- Conditional probability, 754
- Conditioning algorithms, 274
- Confidentiality, 23, 24, 538
 - data, 31–32
 - MiniSec, 740
 - public-key cryptosystem, 291
 - S/MIME, 611–613
 - security controls, 714
- Confidentiality-related threats, 607
- Configuration payload, 667
- Confusion, 118–119
- Congruences
 - properties of, 51
 - relation, 51
 - relation mod, 81–82
- Congruent modulo n , 51
- Connection protocol, 560–564
 - channel mechanism, 560
 - close a channel, 560
 - data transfer, 560
 - open a new channel, 560
 - channel types, 561
 - direct-tcpip, 561
 - forwarded-tcpip, 561
 - session, 561
 - x11, 561
 - port forwarding, 562–564
- Consistency, 249
- Constant exponentiation time, 307
- Constant polynomial, 145
- Constrained device, 441
 - categories of
 - chip area, 442
 - communications transmission rate, 442
 - energy consumption, 442
 - execution time, 442
 - program code size and RAM size, 442
- Content types, 604–605
 - application type, 605
 - message type, 605
 - message/external-body subtype, 605
 - message/partial subtype, 605
 - message/rfc822 subtype, 605
 - multipart type, 605
 - multipart/alternative subtype, 605
 - multipart/digest subtype, 605
 - multipart/mixed subtype, 605
 - multipart/parallel subtype, 605
 - text type, 605
- Content-Description header fields, 604
- Content-ID header fields, 604
- Content-Transfer-Encoding header fields, 604
- Content-Type header fields, 603
- Conventional encryption, 84, 87, 291
 - attacking, 87
 - secure use of, 85
- Cookie exchange, 662
- Core network, 732
- Counter (CTR) mode, 212, 216–218
 - advantages of, 217–218
 - hardware efficiency, 217
 - preprocessing, 218
 - provable security, 218
 - random access, 218
 - simplicity, 218
 - software efficiency, 218
- Counter Mode-CBC MAC Protocol (CCMP), 592
- CREATE_CHILD_SA exchange, 664
- Credential, 503
- Credential service provider (CSP), 502
- CRT. *See* Chinese remainder theorem (CRT)
- Cryptanalysis, 84, 351–352, 459
 - and brute-force attack, 87–89
 - computationally secure, 89
 - types of attacks on encrypted messages, 88
 - unconditionally secure, 89
- compression function, 351
- computational effort for, 334
- MAC, 391
- public-key, 296
- RSA algorithm, 305
- strong encryption, 89
- structure of secure hash code, 351
- Cryptographic algorithms, 33, 643, 738–739
 - keyless algorithms, 34
 - cryptographic hash function, 34
 - pseudorandom number generator, 34
 - lightweight, 442, 448–456
 - asymmetric, 456
 - authenticated encryption, 448–451
 - hash functions, 451–454
 - message authentication codes, 454–456
 - single round encryption, 450
 - post-quantum
 - code-based, 463, 464, 466–467
 - digital signatures, 462
 - encryption, 463
 - hash-based digital signature, 463, 464, 469–472
 - KEMs, 463
 - multivariate-based, 463, 464, 467–469
 - security mechanisms, 33
 - single-key algorithms, 34–35
 - message authentication code, 35
 - symmetric encryption algorithms, 35
- Skipjack, 738
- two-key algorithms, 34, 35–36
 - asymmetric encryption algorithms, 35
 - digital signature algorithm, 36
 - key exchange, 36
 - user authentication, 36
- Cryptographic checksum, 385
- Cryptographic hash functions, 34, 338–373, 411
 - applications of, 339–344
 - collision resistant, 347
 - digital signatures, 342–343
 - intrusion detection, 344
 - message authentication, 349–342
 - one-way password file, 343
 - preimage resistant, 347
 - PRF, 344
 - PRNG, 344
 - properties, relationship, 348
 - pseudorandomness, 348

- Cryptographic hash functions (*Continued*)
 - requirements and security, 346–352
 - brute-force attacks, 348–351
 - collision, 346
 - cryptanalysis, 351–352
 - preimage, 346
 - second preimage resistant, 347
 - resistance properties, 348
 - virus detection, 344
- Cryptographic system, 84
- Cryptographically secure pseudorandom bit generator (CSPRBG), 254
- Cryptography, 33–36, 84, 87
 - number of keys used, 87
 - conventional encryption, 87
 - secret-key, 87
 - single-key, 87
 - symmetric key, 87
 - plaintext, 87
 - block cipher, 87
 - stream cipher, 87
 - transforming plaintext to ciphertext, 87
 - product systems, 87
- Cryptology, 84
- Cryptoperiod, 459–460
- Cryptosystem, 461–462
- CSPRBG. *See* Cryptographically secure pseudorandom bit generator (CSPRBG)
- CTR mode. *See* Counter (CTR) mode
- CTR_DRBG, 256, 257–260
- Cubic equation, 324, 326, 329–330
- Cybersecurity
 - availability, 24
 - objectives, 23–25
 - confidentiality
 - data, 23
 - privacy, 24
 - integrity, 24
- Cyclic group, 139
- D**
- DANE. *See* DNS-based authentication of named entities (DANE)
- Data aggregation, 689
- Data authentication, 740
- Data authenticity, 24
- Data Authentication Algorithm (DAA), 396–397
- Data breaches, 715–716
- Data collection, 689
- Data confidentiality, 23, 31–32
 - CCMP, 593
 - TKIP, 592
- Data encryption algorithm (DEA), 123
- Data Encryption Standard (DES), 121, 123–125, 286
 - avalanche effect, 125–127
 - DAA, 396–397
 - decryption, 125, 775
 - double, 202–204
 - meet-in-the-middle attack, 204
 - reduction to single stage, 203–204
 - encryption, 124–125
 - encryption algorithm, 768
 - example, 125–127
 - initial permutation, 769–771
 - key generation, 774
 - key schedule calculation, 774–775
 - permutation tables, 769–771
 - permuted input, 124
 - preoutput, 125
 - s-boxes, 773–774
 - single round, 771–775
 - strength of, 128–129
 - nature of DES algorithm, 128–129
 - timing attacks, 129
 - use of 56-bit keys, 128
 - subkey, 125
 - triple
 - known-plaintext attack on, 206
 - with three keys, 207
 - with two keys, 204–207
- Data integrity, 24, 32, 33
- Data loss prevention (DLP), 723
- Data management security, 735
- Data modification, 29
- Data normalization, 689
- Data origin authentication, 31
- Database, 619–620
 - distributed, 619
 - SAD (*See* Security association database (SAD))
- DEA. *See* Data encryption algorithm (DEA)
- Deciphering, 84
- Decryption, 84, 294
 - algorithm, 85, 289
 - DES, 125
 - elliptic curve, 332–334
 - Feistel cipher, 120, 121–123
 - FPE, 227–229
 - signature verification, 433
 - tables for substitution, 116
- Deeply embedded systems, 440–441
- Delete payload, 667
- Demilitarized zone (DMZ) networks, 680–681
- Denial of service (DoS), 29, 569
- Denial-of-service (DoS) attack
 - cloud security, 721
 - construction, 692–694
 - consumes data transmission, 692
 - countermeasures
 - detection and filtering, 694
 - prevention and preemption, 694
 - traceback and identification, 694
 - description, 690–692
 - direct, 692
 - example, 691
 - flooding-based, 693
 - internal resource, 690–691
 - reflector, 692
 - scanning process, 692–694
 - hit list, 694
 - local subnet, 694
 - random, 694
 - topological, 694
 - STRIDE threat model, 714
 - SYN flood attack, 690–691
- DES. *See* Data Encryption Standard (DES)
- Deskewing algorithms, 274
- Determinant, 97
- Deterministic primality algorithm, 68
- Device security, 36–37, 572–574
- DH. *See* Diffie-Hellman (DH)
- Diffie-Hellman (DH)
 - key exchange, 315–316
 - algorithm, 316–317, 661–662
 - analog, 332
 - discrete logarithm, 316
 - key exchange protocols, 318
 - man-in-the-middle attack, 318–319
 - values, 664
 - timing attacks, 129
- Diffusion, 118–119
- Digital random number generator (DRNG), 277–280
 - hardware architecture, 278–279
 - CBC-MAC/CMAC, 278–279
 - Intel DRNG logical structure, 280
 - Intel processor chip, 278
 - logical structure, 279–280
- Digital Signature Algorithm (DSA), 417, 423–427
 - approach, 423–425
 - signing and verifying, 426
- Digital signatures, 33, 288, 292, 294, 663
 - algorithm, 36
 - attacks and forgeries
 - adaptive chosen message attack, 419
 - directed chosen message attack, 419
 - existential forgery, 420
 - generic chosen message attack, 419
 - key-only attack, 419
 - known message attack, 419
 - selective forgery, 420
 - total break, 420
 - universal forgery, 420
 - cryptographic hash functions, 342–343
 - definition, 417
 - direct, 420–421
 - ECDSA, 427–430
 - Elgamal signature scheme, 421–422
 - essential elements, 418
 - NIST digital signature algorithm, 423–427
 - properties, 418–419
 - requirements, 420
 - quantum computing, 462
 - Schnorr signature scheme, 422–423
 - simplified examples, 343
- Digrams, 94–96
- Direct DDoS, 692
- Direct digital signature, 420–421
- Direct historical trust, 41
- Directed chosen message attack, 419
- Discrete logarithms, 71–76, 316
 - calculation of, 75–76
 - for modular arithmetic, 73–75
 - powers of integer, 71–73
- Disk drives, 272–273
- Distributed database, 619
- Distribution system (DS), 575, 577, 579
- Distributive laws, 54, 139
- Divides, 45, 148
- Divisibility, 45–46
- Division algorithm, 46–47
- Divisor, 45, 148
- DMZ. *See* Demilitarized zone (DMZ) networks

- DNS. *See* Domain name system (DNS)
 - DNS Security Extensions (DNSSEC), 607, 619–622
 - operation, 622
 - resource records for, 622
 - DNS-based authentication of named entities (DANE), 607, 622–625
 - S/MIME, 625
 - SMTP, 625
 - TLSA record, 623–624
 - Certificate Association Data, 624
 - matching type field, 624
 - selector field, 624
 - DNSSEC. *See* DNS Security Extensions (DNSSEC)
 - Domain Name System (DNS), 600, 680
 - database, 619–620
 - distributed database, 620
 - domain name space, 619
 - elements, 619
 - name resolution, 621
 - name servers, 619
 - operation, 620–621
 - resolvers, 619
 - variable-depth hierarchy
 - for names, 619
 - Domain-Based Message Authentication, Reporting and Conformance (DMARC), 608–609, 634–638
 - functional flow, 637
 - identifier alignment, 634
 - on receiver side, 636
 - reports, 638
 - on sender side, 634–636
 - tag and value descriptions, 635
 - DomainKeys Identified Mail (DKIM), 608, 628–633
 - deployment example, 631
 - email threats, 628–630
 - capabilities, 629
 - characteristics, 629
 - location, 630
 - functional flow, 631–633
 - strategy, 630–631
 - DoS. *See* Denial of service (DoS)
 - Double encryption, 522
- E**
- EAP. *See* Extensible Authentication Protocol (EAP)
 - Ease of analysis, 121
 - Eavesdropping, 27
 - ECB. *See* Electronic codebook (ECB)
 - ECC. *See* Error correction code (ECC)
 - Electronic codebook (ECB), 207–210, 740–741
 - characteristic of, 208
 - diffusion, 210
 - error propagation, 209
 - error recovery, 209
 - modes of operation, 207
 - overhead, 209
 - security, 210
 - Electronic home appliances, 443
 - Electronic mail security, 598–638, 723
 - DANE, 607, 622–625
 - Secure/Multipurpose Internet Mail Extension, 625
 - Simple Mail Transfer Protocol, 624–625
 - TLSA record, 623–624
 - DKIM, 608, 628–633
 - email threats, 628–630
 - functional flow, 631–633
 - strategy, 630–631
 - DMARC, 634–638
 - functional flow, 637
 - identifier alignment, 634
 - on receiver side, 636
 - reports, 638
 - on sender side, 634–636
 - tag and value descriptions, 635
 - DNSSEC, 607, 619–622
 - operation, 622
 - resource records for, 622
 - email format, 601–607
 - MIME, 602–607
 - RFC 5,342, 602
 - email threats and comprehensive email security, 607–609
 - Internet mail architecture, 599–601
 - email components, 599–600
 - email protocols, 600–601
 - S/MIME, 607, 609–619
 - certificate processing, 618
 - enhanced security services, 618–619
 - message content types, 614
 - messages, 614–618
 - operational description, 610–613
 - SPF, 607–608, 625–228
 - mechanisms, 627
 - modifiers, 627
 - operation, 628
 - on receiver side, 627–628
 - on sender side, 626
 - Elgamal cryptographic system, 319–322
 - Elgamal digital signature scheme, 421–422
 - Elliptic curve, 324
 - Elliptic curve arithmetic, 322–331
 - abelian groups, 323–324
 - associative, 323
 - closure, 323
 - commutative, 323
 - elliptic curve, 324
 - identity element, 323
 - inverse element, 323
 - over $GF(2^m)$, 329–331
 - finite field, 329
 - points on, 329
 - over real numbers, 324–326
 - algebraic description of
 - addition, 326
 - example of, 325
 - geometric description of
 - addition, 324–326
 - Weierstrass equation, 324
 - over Z_p , 326–329
 - binary curve, 326
 - points on, 327
 - prime curve, 326
 - Elliptic curve cryptography (ECC), 322–323, 326
 - computational effort for
 - cryptanalysis, 334
 - Diffie-Hellman key exchange analog, 332
 - encryption/decryption, 332–334
 - order, 332
 - security of, 334
 - Elliptic Curve Digital Signature Algorithm (ECDSA)
 - generation and authentication, 428–430
 - global domain parameters, 428
 - key generation, 428
 - process involved in, 427
 - signing and verifying, 429
 - Email
 - compatibility, 613
 - components, 599–600
 - ADMD, 600
 - DNS, 600
 - MDA, 599
 - MHS, 599
 - MS, 599
 - MSA, 599
 - MTA, 599
 - MUA, 599
 - format, 601–607
 - MIME, 602–607
 - RFC 5,342, 602
 - protocols, 600–601
 - IMAP, 601
 - POP3, 601
 - SMTP, 599–601
 - security, 723
 - threats, 607–609, 628–630
 - capabilities, 629
 - characteristics, 629
 - location, 630
 - Encapsulating Security Payload (ESP), 644, 649–657
 - anti-replay service, 651–652
 - receiver, 652
 - replay attack, 651–652
 - sender, 652
 - encryption and authentication
 - algorithms, 650, 653
 - format, 650
 - information, 646
 - padding, 651
 - protocol operation, 657
 - transport and tunnel modes, 652–657
 - Enciphering, 84
 - Encoded message (EM) verification, 433–435
 - Encrypted messages, types of
 - attacks on, 88
 - chosen ciphertext, 88
 - chosen plaintext, 88
 - chosen text, 88
 - ciphertext only, 88
 - known plaintext, 88
 - Encrypted payload, 667
 - Encryption, 84, 294, 723
 - algorithm, 84, 288
 - asymmetric, 35–36
 - CFB mode, 212
 - cloud security as service, 723
 - conventional, 291
 - and decryption tables for
 - substitution, 116
 - DES, 124–125
 - elliptic curve, 332–334
 - Feistel cipher, 120

- Encryption (*Continued*)
 FPE, 227–229
 Grain-128a, 272
 message (*See* Message encryption)
 public-key, 290, 291
 scheme
 computationally secure, 89
 unconditionally secure, 89
 storage requirements, 220–221
 symmetric, 35
 symmetric keys, 463
 wireless security measures, 569
- End-to-end encryption, 475
- End-to-end IPsec Transport-Mode Encryption, 654
- Energy consumption, 442
- Enhanced nondeterministic random number generator (ENRNG), 279
- Enhanced security services, 618–619
 secure mailing lists, 619
 security labels, 618
 signed receipts, 618
 signing certificates, 619
- ENRNG. *See* Enhanced nondeterministic random number generator (ENRNG)
- Entanglement, 457
- Entropy, 760–762
 conditional, 763
 function, 762–763
 and secrecy, 764
- Entropy rate, 273
- Entropy source, 248
 NIST CTR_DRBG, 258–259
 TRNG, 272–273
 disk drives, 272–273
 sound/video input, 272
- Equivalent inverse cipher, 191–193
- Error control
 external, 383
 internal, 383
- Error correction code (ECC), 466–467
- Error propagation, 209
- Error recovery, 209
- ESMTP. *See* Extended SMTP (ESMTP)
- ESS. *See* Extended service set (ESS)
- Euclidean algorithm, 47–50
 example, 50
 extended, 57–59
 greatest common divisor, 47–48
 for polynomials, 150, 157
 relatively prime, 47
 revisited, 56–57
- Euler's theorem, 64–65
- Euler's totient function, 63–64
- Execution time, 442
- Existential forgery, 420
- Extended Euclidean algorithm, 57–59
- Extended service set (ESS), 575, 578
- Extended SMTP (ESMTP), 601
- Extensible Authentication Protocol (EAP), 84
 payload, 667
- External error control, 383
- F**
- Factor, 148
- Factoring problem, 304–306
- False negatives, 684
- False positives, 684
- Fast software encryption/decryption, 121
- Fault-based attack, 307–308
- FCS. *See* Frame check sequence (FCS)
- Federal Information Processing Standards (FIPS), 41
- Federated identity management, 526
 identity federation, 528–530
 identity management, 526–528
- Feedback characteristic of modes of operation, 219
- Feistel cipher, 117–123
 confusion, 118–119
 decryption, 120, 121–123
 design features, 120–121
 diffusion, 118–119
 encryption, 120
 example, 123
 parameters, 120–121
 structure, 115–117, 119–121
- Feistel structure for FPE, 227–232
 bit length, 232
 character strings, 229–231
 encryption and decryption, 227–229
 function F_K , 231–232
 message length, 232
 radix, 232
- Fermat's theorem, 62–63
- Fields, 136, 140–141, 167
 multiplicative inverse, 140
 types of, 142
- Finite fields, 136, 329
 abelian group, 138–139
 arithmetic, 167–168
 irreducible, 167
 cyclic group, 139
 fields, 140–141
 of form $GF(2^n)$, 151–162
 computational considerations, 157–159
 generator, 160–162
 modular polynomial arithmetic, 153–155
 motivation, 151–153
 multiplicative inverse, 155–157
 of form $GF(p)$, 141–144
 multiplicative inverse, 143–144
 order p , 141–143
 groups, 137–138
 polynomial arithmetic
 with coefficients in Z_p , 146–149
 greatest common divisor, 150–151
 ordinary, 145–146
 rings, 139–140
- Finite group, 138
- FIPS. *See* Federal Information Processing Standards (FIPS)
- Firewall, 36, 573, 574
 capabilities, 673–674
 characteristics, 673–674
 behavior control, 673
 direction control, 673
 service control, 673
 user control, 673
 configuration example, 681
 internal and external, 680–681
 limitations, 674
 types of, 674–681
 application-level, 679–680
 circuit-level, 680
 packet filtering, 674–678
 stateful inspection, 678–679
- First assertion, 69–70
- Fog, 730–732
- Forensics, 690
- Format-preserving encryption (FPE), 225–239
 AES vs., 225
 applications, 225–226
 difficulties in designing an, 226–227
 Feistel structure for, 227–232
 bit length, 232
 character strings, 229–231
 encryption and decryption, 227–229
 function F_K , 231–232
 message length, 232
 radix, 232
 motivation, 225–226
 NIST methods for, 233–239
 FF1 algorithm, 233–236
 FF2 algorithm, 237–238
 FF3 algorithm, 238–239
 notation in, 230
 parameters in, 230
- Forward add round key transformation (AddRoundKey), 183
- Forward mix column transformation (MixColumns), 180
- Forward shift row transformation (ShiftRows), 179
- Forward substitute byte transformation (SubBytes), 174
- Forward unpredictability, 250
- 4-way handshake, 591
- FPE. *See* Format-preserving encryption (FPE)
- Frame check sequence (FCS), 383, 577
- Frequency test, 250
- G**
- Galois/counter mode (GCM), 402–405
 authentication and encryption
 functions, 403
 message authentication code, 404
- Generalized number field sieve (GNFS), 305
- Generate function, 259
- Generator, 139, 160–162
- Generic chosen message attack, 419
- GMK. *See* Group master key (GMK)
- GNFS. *See* Generalized number field sieve (GNFS)
- Grain stream cipher, 265
- Grain-128a, 269–272
 authentication, 272
 encryption, 272
 key and IV initialization, 270–271
 output for encryption, 269–270
 Stream Cipher, 271
- Greatest common divisor, 47–48
 finding, 48–50, 150–151
- Group master key (GMK), 588, 589, 590
- Group temporal key (GTK), 590
- Groups, 137–138
 associative, 137
 closure, 137
 commutative, 138
 cyclic, 139

- distribution, 592
 - finite, 138
 - generate, 139
 - generator, 139
 - identity element, 138
 - infinite, 138
 - inverse element, 138
 - keys, 590–591
 - order of, 138
 - permutation, 138
 - Grover's algorithm, 458
- H**
- Handshake protocol
 - action, 543
 - CipherSpec
 - Cipher algorithm, 544
 - Cipher type, 544
 - hash size, 544
 - is exportable, 544
 - IV size, 544
 - key material, 544
 - MAC algorithm, 544
 - CipherSuite parameter
 - anonymous Diffie-Hellman, 544
 - ephemeral Diffie-Hellman, 544
 - fixed Diffie-Hellman, 544
 - RSA, 544
 - client authentication and key
 - exchange, 546
 - certificate message, 546
 - ephemeral or anonymous
 - Diffie-Hellman, 546
 - fixed Diffie-Hellman, 546
 - RSA, 546
 - finished message, 547
 - security capabilities, 542–544
 - cipher suite, 542
 - compression method, 542–544
 - random, 542
 - session ID, 542
 - version, 542
 - server authentication and key
 - exchange, 544–546
 - anonymous Diffie-Hellman, 545
 - ephemeral Diffie-Hellman, 545
 - RSA key exchange, 545
 - Hardware fault-based attack, 304
 - Hash code, 338
 - digital signature, 343
 - message authentication, 341–342
 - secure, general structure of, 351
 - Hash functions, 338, 381
 - attack against, 340
 - cryptographic, 338–373
 - applications of, 339–344
 - brute-force attacks, 348–351
 - collision, 346
 - collision resistant, 347
 - cryptanalysis, 351–352
 - digital signatures, 342–343
 - intrusion detection, 344
 - message authentication, 339–342
 - one-way password file, 343
 - preimage, 346
 - preimage resistant, 347
 - PRF, 344
 - PRNG, 344
 - properties, relationship, 348
 - pseudorandomness, 348
 - requirements and security, 346–352
 - resistance properties, 348
 - second preimage resistant, 347
 - virus detection, 344
 - internal state and output sizes, 451
 - keyed, 342
 - and message authentication codes, 252, 391–395
 - message size, 451
 - PHOTON permutation, 452–453
 - PHOTON sponge structure, 451–452
 - PRNG on, 410–411
 - resistance properties, 348
 - strong, 347
 - TRNG, 274–275
 - two simple, 344–346
 - Hash tree, 470
 - Hash-based digital signature, 463, 464, 469–472
 - Hash value, 347, 349, 353
 - Header fields, 603–604
 - Content-Description, 604
 - Content-ID, 604
 - Content-Transfer-Encoding, 604
 - Content-Type, 603
 - MIME-Version, 603
 - Health testing, 275–277
 - on conditioning function, 277
 - on noise source, 275–277
 - Hill cipher, 97–100
 - algorithm, 98–100
 - concepts from linear algebra, 97–98
 - determinant, 97
 - Hit list, 694
 - HMAC, 391–395
 - algorithm, 392–395
 - design objectives, 392
 - efficient implementation
 - of, 394
 - security of, 395
 - structure, 393
 - Host-based IDS, 682, 684–685
 - HTTPS (Hyper Text Transfer Protocol Secure), 550–552
 - connection closure, 552
 - connection initiation, 552
 - Human resource security, 39
 - Hybrid cloud, 706–707
- I**
- IAB. *See* Internet Architecture Board (IAB)
 - IaaS. *See* Infrastructure as a service (IaaS)
 - Ideal block cipher, 115–117
 - Identification payload, 667
 - Identification string exchange, 555
 - Identities, 54
 - Identity and access management (IAM), 716, 723
 - Identity element, 54, 138, 323
 - Identity federation, 528–530
 - examples, 529
 - Identity management system
 - administrators, 527
 - attribute service, 527
 - authorization, 527
 - data consumers, 528
 - identity provider, 527
 - identity services, 527
 - key services, 527
 - management, 527
 - point of contact, 527
 - principal, 527
 - provisioning, 527
 - SSO protocol services, 527
 - trust services, 527
 - Identity provider, 527
 - Identity theft (MAC spoofing), 568
 - IEEE 802.11 wireless LAN, 574–580
 - association-related services, 579–580
 - association, 580
 - BSS transition, 580
 - disassociation, 580
 - ESS transition, 580
 - no transition, 580
 - reassociation, 580
 - MPDU format, 576
 - network components and
 - architectural model, 577–578
 - ESS, 578
 - protocol architecture, 575–577
 - logical link control, 577
 - media access control, 576–577
 - physical layer, 575
 - protocol stack, 576
 - services, 578–580
 - association-related services, 579–580
 - distribution of messages within
 - a DS, 579
 - terminology, 575
 - Wi-Fi alliance, 575
 - IEEE 802.11i wireless LAN security, 580–594
 - authentication phase, 586–588
 - access control approach, 586
 - EAP exchange, 587–588
 - MPDU exchange, 587
 - discovery phase, 584–586
 - MPDU exchange, 585–586
 - security capabilities, 585
 - elements of, 582
 - key management phase, 588–592
 - group key distribution, 592
 - group keys, 590–591
 - pairwise key distribution, 591–592
 - pairwise keys, 590
 - phases of operation, 581–584
 - authentication, 583
 - connection termination, 584
 - discovery, 583
 - key generation and distribution, 583
 - protected data transfer, 583
 - protected data transfer phase, 592–593
 - CCMP, 593
 - TKIP, 592–593
 - pseudorandom function, 593–594
 - services, 581
 - access control, 581
 - authentication, 581
 - privacy with message integrity, 581
 - IETF. *See* Internet Engineering Task Force (IETF)
 - IKE. *See* Internet Key Exchange (IKE)
 - IKEv2 Exchanges, 664

- IMAP. *See* Internet Mail Access Protocol (IMAP)
- Incident management, 689–690
 - alerting, 689
 - correlation, 689
 - data aggregation, 689
 - data collection, 689
 - data normalization, 689
 - reporting/compliance, 689
- Independent BSS (IBSS), 577
- Indeterminate, 145
- Index, 74
- Industrial systems, 443–444
- Infinite field, 141
- Infinite group, 138
- Information, 758, 759–760
- Information and entropy, 758–763
- Information disclosure, 714
- Information security, 23
 - challenges of, 25–26
- Information technology (IT), 729
- Informational exchange, 664
- Infrastructure as a service (IaaS), 703–704
- Initialization value (IV), 650
- Initialization vectors, 538
- Inputs
 - for single AES round, 184
 - sound/video, 272
- Insecure programming, 735
- Insufficient due diligence certification, 720
 - CSP's, 720
 - data protection, 720
 - infrastructure, 720
- Integral domain, 140
- Integration, 579, 734
- Integrity, 24, 25
 - data, 24
 - system, 24
 - trustworthiness, 38
- Integrity-related threats, 607
- Intel digital random number generator, 277–280
 - hardware architecture, 278–279
 - logical structure, 279–280
- Internal error control, 383
- Internal resource attack, 690–691
- International Organization for Standardization (ISO), 42
- International Telecommunication Union (ITU), 42
- Internet Architecture Board (IAB), 41, 642
- Internet Key Exchange (IKE), 644, 660–667
 - header and payload formats, 665–667
 - key determination
 - authentication, 663
 - cookie exchange, 662
 - features, 662–663
 - IKEv2 Exchanges, 664
 - nonces, 663
 - protocol, 661–663
 - payload types, 666–667
 - requirements, 662–663
- Internet Engineering Task Force (IETF), 41
- Internet Mail Access Protocol (IMAP), 601
- Internet mail architecture, 599–601
 - email components, 599–600
 - ADMD, 600
 - DNS, 600
 - MDA, 599
 - MHS, 599
 - MS, 599
 - MSA, 599
 - MTA, 599
 - MUA, 599
 - email protocols, 600–601
 - IMAP, 601
 - POP3, 601
 - SMTP, 601
- Internet of Things (IoT), 728
 - and cloud context, 730–732
 - components, 729–730
 - evolution
 - information technology, 729
 - operational technology, 729
 - personal technology, 729
 - sensor/actuator technology, 729
 - security concepts, 733–736
 - ecosystems, 734–735
 - environment, 739
 - gateway, 737–738
 - tamper resistance and detection, 736
 - things on, 728
- Internet security. *See* Network security
- Internet Security Association and Key Management Protocol (ISAKMP), 661
- Internet Service Provider (ISP), 628, 643
- Internet Society (ISOC), 41
- Intrusion, 682
- Intrusion detection system (IDS), 37, 344, 682–686, 723
 - approaches, 683–684
 - anomaly detection, 683–684
 - misuse detection, 683
 - components
 - analyzers, 682
 - sensors, 682
 - user interface, 682
 - definition, 682
 - host-based, 682
 - host-based techniques, 684–685
 - network-based, 682, 685–686
 - principles, 683
- Intrusion management, 722, 723
- Intrusion prevention systems (IPs), 36, 723
- Inverse add round key transformation, 183
- Inverse element, 53, 138, 323
- Inverse mix column transformation (InvMixColumns), 181
- Inverse shift row transformation (InvShiftRows), 179
- Inverse substitute byte transformation (InvSubBytes), 178
- InvMixColumns, 192–193
- InvShiftRows, 192
- InvSubByte, 192
- Iota step function, 373
- IoT ecosystems
 - attack surfaces, 734
 - deployment, 734
 - device resources, 734
 - insecure programming, 735
 - integration, 734
 - lack of expertise, 734
 - low cost, 734
 - safety aspects, 734
 - security updates, 734–735
 - standards and regulations, 734
 - unclear liabilities, 735
- IoT gateway security
 - communication, 737
 - data management, 737
 - functions, 737–738
 - mutual authentication and authorization, 737
 - policies and techniques, 737
 - security audit, 737
 - service provision, 737
- IoT security
 - concepts, 733–736
 - elements, 733
 - environment
 - data protection and confidentiality, 739
 - internet protocol and network security, 739
 - tamper resistance and detection, 739
 - user authentication and access control, 739
 - objectives, 733–736
 - detecting security events and incidents, 735
 - logical access, 735
 - maintaining functionality, 736
 - physical access, 735
 - preventing data, 735
 - protecting IoT components, 735
 - restoring system, 736
- IoT/cloud context, 730–732
 - cloud, 732
 - comparison of cloud and fog features, 732
 - core, 732
 - edge, 730
 - fog, 730–732
 - gateways, 730
- IoT-enabled device
 - components
 - actuator, 730
 - microcontroller, 730
 - power supply, 730
 - sensor, 729–730
 - transceiver, 730
- IP security (IPsec), 642–667
 - applications, 643
 - architecture, 645
 - authentication plus confidentiality, 658–659
 - destination address, 645
 - documents, 643–644
 - AH, 644
 - architecture, 643
 - cryptographic algorithms, 644
 - ESP, 644
 - IKE, 644
 - ESP, 649–657
 - anti-replay service, 651–652
 - encryption and authentication algorithms, 650, 653
 - format, 650, 651
 - information, 646

- padding, 651
 - protocol operation, 657
 - transport and tunnel modes, 652–657
 - IKE, 644
 - header and payload formats, 665–667
 - key determination protocol, 661–664
 - SA, 645
 - combinations of, 659–660
 - IP destination address, 645
 - Security Protocol Identifier, 645
 - SPI, 645
 - SAD, 645–646
 - AH information, 646
 - Anti-Replay Window, 646
 - ESP information, 646
 - IPsec Protocol Mode, 646
 - Lifetime of this Security Association, 646
 - Path MTU, 646
 - Sequence Counter Overflow, 646
 - Sequence Number Counter, 646
 - SPI, 645
 - services, 644
 - SPD, 645, 646–647
 - local and remote ports, 647
 - local IP address, 647
 - name, 647
 - next layer protocol, 647
 - remote IP address, 647
 - traffic processing, 648–649
 - inbound packets, 649
 - outbound packets, 648
 - transport and tunnel modes, 652–657
 - VPN with tunnel mode, 656
 - IPv4, 643
 - IPv6, 643, 647
 - Iris images, 504
 - Irreducible polynomial, 148, 154
 - Irreversible mapping, 115
 - ISAKMP. *See* Internet Security Association and Key Management Protocol (ISAKMP)
 - IS-Box, 176
 - ISO. *See* International Organization for Standardization (ISO)
 - ISOC. *See* Internet Society (ISOC)
 - ISP. *See* Internet Service Provider (ISP)
 - Iteration function, 362
 - ITU Telecommunication Standardization Sector (ITU-T), 42
 - K**
 - Keccak, 362, 364, 366, 368, 370
 - KEK. *See* Key encryption key (KEK)
 - KEMs. *See* Key-establishment mechanisms (KEMs)
 - Kerberos, 510–524
 - environmental shortcomings
 - authentication forwarding, 521
 - encryption system dependence, 521
 - internet protocol dependence, 521
 - interrealm authentication, 521
 - message byte ordering, 521
 - ticket lifetime, 521
 - exchanges, 518
 - motivation, 511–512
 - reliable, 511
 - scalable, 511
 - secure, 511
 - transparent, 511
 - overview of, 517
 - principal, 519
 - technical deficiencies
 - double encryption, 522
 - password attacks, 522
 - PCBC encryption, 522
 - session keys, 522
 - Version 4, 512–520
 - authentication dialogue, 512–513
 - authentication service
 - exchange, 516
 - client/server authentication
 - exchange, 516
 - message exchanges, 516
 - protocol, 517
 - secure authentication dialogue, 513–515
 - simple authentication dialogue, 512–513
 - ticket-granting service exchange, 516
 - Version 5, 521–524
 - authentication dialogue, 522–524
 - authentication service
 - exchange, 522
 - message exchanges, 523
 - nonce, 522
 - options, 522
 - realm, 522
 - ticket-granting service
 - exchange, 523
 - times, 522
- Kerberos realm, 519–520
- Key
 - asymmetric encryption, 290
 - determination protocol, 660–664
 - expansion algorithm, 184–186
 - generation, 303–304
 - length, 258
 - schedule algorithm, 131
 - size, 121
 - 3DES, 204–207
 - unwrapping, 407–410
- Key distribution center (KDC), 476, 507–509, 524–525
- Key distribution, symmetric
 - using asymmetric encryption, 478–480
 - secret key distribution, 480
 - simple secret key distribution, 478–480
 - using symmetric encryption, 474–477
 - key distribution option, 474–477
- Key distribution technique, 474–475
- Key encryption key (KEK), 405
- Key exchange, 36, 294, 556
 - Diffie-Hellman, 315–319
 - algorithm, 316–317, 661–662
 - analog, 332
 - discrete logarithm, 316
 - key exchange protocols, 318
 - man-in-the-middle attack, 318–319
 - payload, 667
- Key expansion, 780–781
- Key hierarchy, 477
- Key management and distribution
 - hierarchy, 477
 - public keys distribution, 481–485
 - public-key infrastructure, 494–496
- symmetric key distribution
 - using asymmetric encryption, 478–480
 - using symmetric encryption, 474–477
 - X.529 certificates, 485–493
- Key translation center (KTC), 476
- Key usage, 492
- Key Wrap (KW) mode, 405–406
- Key wrapping
 - algorithm, 406–407
 - KEK, 405
 - operation for 256-bit key, 408, 409
 - and unwrapping, 407–410
- Keyed hash function, 342
- Key-establishment mechanisms (KEMs), 463
- Keyless algorithms, 34
 - cryptographic hash function, 34
 - pseudorandom number generator, 34
- Key-only attack, 419
- Keystream, 260–261
- Known message attack, 419
- Known-plaintext, 88
 - attack on triple Data Encryption Standard, 205, 206
- KW mode. *See* Key Wrap (KW) mode
- L**
- Lanes, 366, 367
- Lattice, 464
- Lattice-based cryptography, 463–466
- Lightweight, 439
- Lightweight cryptographic algorithms, 442, 448–456
 - asymmetric, 456
 - authenticated encryption, 448–451
 - hash functions, 451–454
 - message authentication codes, 454–456
 - SipHash, 455
 - single round encryption, 450
- Lightweight cryptography, 439
 - AEAD, 445–447
 - algorithms, 442, 448–456
 - constrained devices, 441
 - categories of, 442
 - classes of, 441
 - deeply embedded systems, 440–441
 - microcontroller, 440
 - profiles for, 445
 - security considerations, 442–444
 - agricultural sensors, 443
 - automobiles, 444
 - home appliances, 443
 - industrial systems, 443–444
 - medical sensors, 443
 - RFID, 442–443
 - smart agricultural sensors, 443
 - security requirements, 445–448
 - trade-offs, 444–445
- Lightweight Directory Access Protocol (LDAP), 724
- Linear algebra operations over Z_n , 750–752
- Linear congruential generators, 252–253
- Linear feedback shift registers, 265–268
- Local forwarding, 563
- Local subnet, 694
- Low energy overhead, 738
- Lucifer cipher, 227

M

- MAC. *See* Message authentication codes (MAC)
- MAC protocol data unit (MPDU), 575, 576
 - CRC, 577
 - destination MAC address, 576
 - exchange, 585–586
 - AS, 587
 - association, 585–586
 - EAP exchange, 587
 - network and security capability discovery, 585
 - open system authentication, 585
 - secure key delivery, 587
 - format, 577
 - MAC Control, 576
 - MAC header, 577
 - MAC trailer, 577
 - MSDU, 576
 - source MAC address, 576
- MAC service data unit (MSDU), 575, 576, 579
- Mail Delivery Agent (MDA), 599
- Mail Submission Agent (MSA), 599
- Malicious association, 568
- Malicious insiders, 717
- Malicious software, 687–690. *See also* Malware
- Malware
 - defense, 688–690
 - elements of, 688
 - endpoint behavior analysis, 689
 - forensics, 690
 - incident management, 689–690
 - network traffic analysis, 688–689
 - payload analysis, 689
 - post-compromise, 688
 - real-time and near-real-time, 688
- types, 687–688
 - backdoor, 687
 - bot, 688
 - mobile code, 688
 - rootkit, 687
 - spyware, 687
 - Trojan horse, 687
 - virus, 687
 - worm, 687
- Management information base (MIB)
 - content, 644
- Mandated trust, 41
- Man-in-the-middle attacks, 29, 318–319, 478, 479, 568
- Manual key management, 660
- Mapping
 - definition, 117
 - irreversible, 115
 - nonsingular, 115
 - policy, 493
 - reversible, 115
- Mask generation function (MGF), 308–309, 430–431
- Masquerade, 29, 380
- Master key, 476, 507–508
- Master secret, 538, 546
 - Diffie-Hellman, 546
 - RSA, 546
- Master session key (MSK), 590
- Matching Type field, 624
- Mathematical attacks, 304
 - Mathematical basis of birthday attack
 - birthday paradox, 789–791
 - duplications, 792–793
 - inequality, 791–792
 - overlapping two sets, 793–794
 - related problem, 789
 - Maurer’s universal statistical test, 250
 - MD4, 352
 - MD5, 351, 362
 - MDA. *See* Mail Delivery Agent (MDA)
 - Measured service, 702
 - Media access control (MAC), 576–577
 - Mediated trust, 41
 - Medical sensors, 443
 - Meet-in-the-middle attack, 204
 - Merkle root, 470
 - Message authentication, 339–342
 - attack against hash function, 340
 - functions, 380–387
 - hash function, 381
 - MAC, 385–387
 - message encryption, 381–385
 - hash code, 341–342
 - keyed hash function, 342
 - message digest, 339
 - requirements, 379–380
 - content modification, 380
 - destination repudiation, 380
 - disclosure, 379
 - masquerade, 380
 - sequence modification, 380
 - source repudiation, 380
 - timing modification, 380
 - traffic analysis, 380
 - simplified examples, 341
 - Message authentication code (MAC), 342, 379, 539
 - authenticated encryption, 399–405
 - CMAC, 399–402
 - GCM, 402–405
 - basic uses of, 386
 - on block ciphers, 396–398
 - CMAC, 397–398
 - DAA, 396–397
 - HMAC, 391–395
 - algorithm, 392–395
 - design objectives, 392
 - efficient implementation of, 394
 - security of, 395
 - structure, 393
 - key wrapping, 405–410
 - algorithm, 406–407
 - KEK, 405
 - operation for 256-bit key, 408
 - and unwrapping, 407–410
 - PRNG using, 412
 - requirements for, 388–390
 - security of, 390–391
 - brute-force attacks, 390–391
 - computation resistance, 390
 - cryptanalysis, 391
 - SipHash, 455
 - characteristics of, 454
 - design of, 454
 - variants, 454
- Message digest, 339
 - generation using SHA-492, 354
- Message encryption, 381–385
 - basic uses of, 381
 - public-key encryption, 384–385
 - symmetric encryption, 381–384
 - external error control, 383
 - internal error control, 383
 - TCP segment, 384
- Message Handling Service (MHS), 599
- Message integrity, 538
 - CCMP, 593
 - TKIP, 592
- Message integrity code (MIC), 592
- Message length, 232
- Message Store (MS), 599–600
- Message Transfer Agent (MTA), 599
- Message type, 605
- Message User Agents (MUA), 599–601
- Message/external-body subtype, 605
- Message/partial subtype, 605
- Message/rfc822 subtype, 605
- MIC. *See* Message integrity code (MIC)
- Michael, 592, 593
- Microcontroller, 440
- Miller-Rabin algorithm, 66–68
 - details of, 67
 - properties of prime numbers, 66–67
 - first property, 66
 - second property, 66
 - repeated use of, 68
- MIME. *See* Multipurpose Internet Mail Extension (MIME)
- MIME-Version header fields, 603
- Min-entropy, 765–767
- MiniSec, 740
 - confidentiality, 740
 - data authentication, 740
 - freshness, 740
 - lost messages, 740
 - low energy overhead, 740
 - replay protection, 740
- Misuse detection, 683
- MixColumns, 171, 173, 194
 - transformation, 180–183, 199–200
- Mobile device security, 570–574
 - cloud-based applications, 570
 - de-perimeterization, 571
 - external business requirements, 571
 - growing use of new devices, 570
 - strategy, 572–574
 - barrier security, 574
 - device security, 572–574
 - elements, 572, 573
 - traffic security, 574
 - threats, 571–572
 - interaction with other systems, 572
 - lack of physical security controls, 571
 - location services, 572
 - by unknown parties, 572
 - untrusted content, 572
 - untrusted mobile devices, 571
 - untrusted networks, 572
- Modification of messages, 29
- Modular arithmetic, 51–59, 143, 151, 155
 - congruences, 51
 - congruent modulo n , 51
 - Euclidean algorithm
 - extended, 57–59
 - revisited, 56–57

- exponentiation in, 300–301
 - modulus, 51
 - operations, 52–53
 - properties of, 53–56, 300
 - reducing k modulo n , 54
 - set of residues/residue classes, 54
 - Modular polynomial arithmetic, 153–155
 - Modulus, 51, 81
 - Monic polynomial, 145
 - Monoalphabetic ciphers, 92–95
 - digrams, 94
 - permutation, 92
 - relative frequency, 93, 94
 - substitution cipher, 92
 - Multifactor authentication, 505
 - Multi-instance model, 715–716
 - Multipart type, 605
 - Multipart/alternative subtype, 605
 - Multipart/digest subtype, 605
 - Multipart/mixed subtype, 605
 - Multipart/parallel subtype, 605
 - Multiple encryption, 202–207
 - double DES, 202–204
 - meet-in-the-middle attack, 204
 - reduction to single stage, 203–204
 - triple DES
 - known-plaintext attack on, 206
 - with three keys, 207
 - with two keys, 204–207
 - Multiplication, 140–141, 158–159, 200
 - Multiplicative identity, 140
 - Multiplicative inverse, 140, 143–144, 155–157
 - Multipurpose Internet Mail Extension (MIME), 602–607
 - canonical form, 606–607
 - content types, 604–605
 - application type, 605
 - message type, 605
 - message/external-body subtype, 605
 - message/partial subtype, 605
 - Message/rfc822 subtype, 605
 - multipart type, 605
 - multipart/alternative subtype, 605
 - multipart/digest subtype, 605
 - multipart/mixed subtype, 605
 - multipart/parallel subtype, 605
 - text type, 605
 - header fields, 603–604
 - Content-Description, 604
 - Content-ID, 604
 - Content-Transfer-Encoding, 604
 - Content-Type, 603
 - MIME-Version, 603
 - native form, 606
 - specification, 603
 - transfer encodings, 605–606
 - base64 transfer encoding, 606
 - quoted-printable, 606
 - use of, 603
- Multirate padding, 363
- Multi-tenant model, 716
- Multivariate polynomial, 467
- Multivariate-based algorithms, 467–469
- Multivariate-based cryptography, 463–464, 467–469
- Mutual authentication, 505–507
 - asymmetric encryption, 524–525
 - and authorization, 737
- challenge/response, 506
- remote user-authentication
 - principles, 505–507
- symmetric encryption, 507–510
- timestamps, 506
- N**
- National Institute of Standards and Technology (NIST), 41, 123, 166
 - digital signature algorithm, 423–427
 - for electronic user authentication, 501–503
 - FPE, 233–239
 - FF1 algorithm, 233–236
 - FF2 algorithm, 236–238
 - FF3 algorithm, 238–239
 - Native form, 606
 - Network injection attack, 569
 - Network protocols security
 - components, 462
 - Network security, 23, 36–37. *See also* Cryptography
 - cloud security as service, 724
 - communications security, 36
 - denial-of-service (DoS) attack, 690
 - construction, 692–694
 - countermeasures, 694
 - description, 690–692
 - flooding-based, 693
 - device security, 36–37
 - elements of, 36
 - firewall, 36, 672–681
 - application-level, 679–680
 - characteristics, 673–674
 - circuit-level, 680
 - DMZ networks, 680–681
 - packet filtering, 674–678
 - stateful inspection, 678–679
 - types of, 674–680
 - intrusion detection system, 36, 682
 - approaches, 683–684
 - host-based, 684–685
 - network-based, 685–686
 - principles, 682
 - intrusion prevention, 36
 - malicious software, 687
 - types of, 687–688
 - malware defense, 688–690
 - Network traffic analysis, 688–689
 - Network-based IDS, 682
 - Network-Based Intrusion Detection Systems (NIDS), 685–686
 - deployment example, 686
 - function, 685
 - placement, 685–686
 - NIDS. *See* Network-Based Intrusion Detection Systems (NIDS)
 - NIDS function, 685
 - NIDS placement, 685–686
 - Next-bit test, 254
 - NIST. *See* National Institute of Standards and Technology (NIST)
 - NIST CTR_DRBG, 257–260
 - entropy source, 257
 - functions, 259
 - generate, 258
 - initialize, 258
 - key length, 258
 - output block length, 258
 - parameters, 258
 - reseed interval, 258
 - seed length, 258
 - update, 259–260
- No zero divisors, 140
- Nonce, 211, 506, 522, 663
 - payload, 667
- Non-deterministic random bit generators (NRBGs) model, 276
- Nonlinear feedback shift registers, 268–269
- Nonrepudiation, 24, 32, 714
- Nonsingular mapping, 115
- Nontraditional networks, 568
- Notarization, 33
- Notify payload, 667
- NRBGs model. *See* Non-deterministic random bit generators (NRBGs) model
- Number of rounds, 121, 130
- Number theory, 45–76
 - Chinese remainder theorem, 69–71
 - discrete logarithms, 71–76
 - calculation of, 75–76
 - for modular arithmetic, 73–75
 - powers of integer, 71–73
 - divisibility, 45–46
 - division algorithm, 46–47
 - Euclidean algorithm, 47–50
 - Euler's theorem, 64–65
 - Euler's totient function, 63–64
 - Fermat's theorem, 62–63
 - modular arithmetic, 51–59
 - Euclidean algorithm revisited, 56–57
 - extended Euclidean algorithm, 57–59
 - modular arithmetic operations, 52–53
 - modulus, 51
 - properties of, 53–56
 - properties of congruences, 51
 - primality, testing for, 66–68
 - algorithm, 68
 - distribution of primes, 68
 - Miller-Rabin algorithm, 66–68
 - prime numbers, 59–62
- O**
- OAEP. *See* Optimal asymmetric encryption padding (OAEP)
 - Oakley Key Determination Protocol, 661
 - OCB. *See* Offset Codebook (OCB) Mode
 - OFB mode. *See* Output feedback (OFB) mode
 - Offset Codebook (OCB) Mode, 740–744
 - encryption and authentication, 742
 - On-demand self-service, 702
 - One-time pad, 103–104
 - One-way authentication
 - asymmetric encryption, 525–526
 - One-way function, 295
 - One-way password file, 343

- Open-source cloud security module, 724–725
 - identity, 724
 - OpenStack, 724
 - policies, 724
 - service catalog, 724
 - token, 724
 - virtual machine, 725
 - Open-source IOT security module, 739–744
 - cryptographic algorithms, 740–741
 - data authentication, 740
 - MiniSec, 740
 - Offset Codebook Mode, 741–744
 - operating modes, 741
 - TinyOS, 739
 - OpenStack, 724
 - Operational technology (OT), 729
 - Operations on vectors and matrices, 747–750
 - arithmetic, 747–748
 - determinants, 748–749
 - inverse of matrix, 749–750
 - Optimal asymmetric encryption padding (OAEP), 308–309
 - Order, 71, 72
 - Order of group, 138
 - Ordinary polynomial arithmetic, 145–146
 - OSI security architecture
 - attacks, 29
 - ITU-T Recommendation X.800, 26–27
 - security attack, 27
 - security mechanism, 27
 - security service, 27
 - threats, 27
 - Output, 235, 257
 - Output block length, 258
 - Output feedback (OFB) mode, 212, 214–216
- P**
- PaaS. *See* Platform as a service (PaaS)
 - Packet filtering firewall
 - attacks and countermeasures, 678
 - IP address spoofing, 678
 - source routing, 678
 - tiny fragment, 678
 - destination IP address, 674
 - example, 676
 - interface, 674–676
 - IP protocol field, 674
 - rule sets, 676–677
 - source and destination
 - transport-level address, 674
 - source IP address, 674
 - weaknesses, 677–678
- Pairwise master key (PMK), 590
- Pairwise transient key (PTK), 590
- Parameters
 - SHA, 353
 - SHA-3, 366
- Passive attack, 27
 - release of message contents, 27
 - traffic analysis, 28
- Password attacks, 522
- Path MTU, 646
- Peer certificate, 537
- Peer entity authentication, 31
- Perfect secrecy, 104, 754–758
- Permutation, 92, 117, 119, 138
- Permuted input, 124
- Personal identification
 - number (PIN), 504
- Personal technology, 729
- Pi step function, 371–372
- PIN. *See* Personal identification number (PIN)
- PKI. *See* Public key infrastructure (PKI)
- Plaintext, 84, 288
 - transforming to ciphertext, 87
- Plaintext–ciphertext pair, 204
- Platform as a service (PaaS), 703
- Playfair cipher, 95–97
 - monarchy, 95
 - plaintext, 96
 - relative frequency of letters, 96
- PMK. *See* Pairwise master key (PMK)
- Point at infinity, 324
- Policy mappings, 493
- Pollard rho method, 334
- Polyalphabetic ciphers, 100–103
 - autokey system, 102
 - one-time pad, 103–104
 - polyalphabetic substitution cipher, 100
 - substitution cipher, 100
- Vernam cipher, 102–103
- Vigenère cipher, 100–102
- Polynomial
 - arithmetic
 - coefficient set, 145
 - with coefficients in Z_p , 146–149
 - constant polynomial, 145
 - Euclidean algorithm for, 150, 157
 - examples of, 147, 149
 - greatest common divisor, 150–151
 - indeterminate, 145
 - modular, 153–155
 - monic polynomial, 145
 - ordinary, 145–146
 - treatment of, 145
 - with coefficients in GF(28), 197–200
 - ring, 146
 - root of, 160
- Port, 562–564
- Post Office Protocol (POP3), 601
- Post-quantum cryptographic algorithms
 - code-based, 463–464, 466–467
 - digital signatures, 462
 - encryption, 463
 - hash-based digital signature, 463–464, 469–472
 - hash tree, 470
 - Lamport’s scheme, 469–470
 - Merkle hash tree, 471–472
 - Merkle root, 470
- KEMs, 463
- multivariate-based, 463–464, 467–469
 - arithmetic in GF(42), 469
 - polynomial, 467
 - public key, 469
 - quadratic polynomial, 467–468
- Post-quantum cryptography, 456
 - algorithms, 459–472
 - computing, 456–457
 - entanglement, 457
 - qubits, 456
 - superposition, 456–457
- cryptoperiods, 459–460
 - algorithms, 459
 - brute-force attacks, 459
 - cryptanalysis, 459
 - quantum safety timeline, 460
 - security threats, 459
 - from SP 820-37, 461
- Grover’s algorithm, 458
- safety, 460–462
 - cryptosystems, 461–462
 - network protocols, 462
 - products, 462
 - security protocols, 462
- Shor’s factoring algorithm, 457–458
 - RSA key length, 458
- Power supply, 730
- Preimage, 346
 - attacks, 349
 - brute-force attacks, 348
- Preimage resistant, 347
- Preoutput, 125
- Pre-shared key (PSK), 590
- PRF. *See* Pseudorandom function (PRF)
- Primality, testing for, 66–68
 - algorithm, 68
 - distribution of primes, 68
 - Miller–Rabin algorithm, 66–68
 - details of, 67
 - repeated use of, 68
 - two properties of prime numbers, 66–67
- Prime curve, 326
- Prime number, 59–62, 143, 152
- Prime polynomial, 148
- Primitive polynomial, 160
- Primitive root, 72, 315
- Privacy, 24
- Privacy of electronic product code (EPC), 443
- Private cloud, 706
- Private keys, 288, 289
 - certificate, 287
 - RSA algorithm, 302–303
- Private-key usage period, 493
- PRNG. *See* Pseudorandom number generator (PRNG)
- Product cipher, 117, 118
- Product systems, 87
- Program code size and RAM size, 442
- Propagating cipher block chaining (PCBC) encryption, 522
- Pseudorandom function (PRF), 247–249, 344, 410, 549
- Pseudorandom number generator (PRNG), 34, 247–249, 252–255, 344
 - Blum Blum Shub generator, 254–255
 - on hash function, 410–411
 - linear congruential generators, 252–253
 - MAC function, 412
 - next-bit test, 254
 - principles of, 246–252
 - algorithm design, 251–252
 - requirements, 249–251
 - TRNGs, PRNGs, and PRFs, 247–249
 - use of random numbers, 246–247

- randomness, 249–250
 - consistency, 249
 - frequency test, 250
 - Maurer’s universal statistical test, 250
 - runs test, 250
 - scalability, 249
 - uniformity, 249
 - requirements, 249–251
 - seed requirements, 250–251
 - unpredictability
 - backward, 250
 - forward, 250
 - using block cipher, 255–260
 - mechanisms, 256
 - NIST CTR_DRBG, 257–260
 - Pseudorandom numbers, 247
 - Pseudorandomness, 348
 - PSK. *See* Pre-shared key (PSK)
 - PTK. *See* Pairwise transient key (PTK)
 - Public cloud, 704–705
 - Public key infrastructure (PKI), 287, 494–496
 - Public keys, 288, 289, 481–485
 - (asymmetric) cryptographic algorithm, 287
 - authority, 482–483
 - certificates, 484–485
 - cryptanalysis, 296
 - public announcement of, 481
 - publicly available directory, 481–482
 - RSA algorithm, 301–302
 - uncontrolled distribution, 481
 - Public-key cryptography, 285–309
 - applications for, 293–294
 - decryption, 294
 - digital signature, 294
 - encryption, 294
 - key exchange, 294
 - authentication, 292, 293
 - characteristics, 288–289
 - ciphertext, 289
 - confidentiality, 291
 - conventional encryption, 291
 - decryption algorithm, 289
 - digital signature, 292
 - encryption algorithm, 288
 - misconception, 286
 - plaintext, 288
 - principles of, 287–296
 - public and private keys, 288, 289
 - public-key cryptanalysis, 296
 - public-key encryption, 288–290
 - requirements for, 294–296
 - one-way function, 295
 - trap-door one-way function, 295
 - secrecy, 293
 - secret key, 290
 - Public-key encryption, 288–291, 384–385, 663
 - Public-key infrastructure (PKI) components
 - certification authority, 494
 - end entity, 494
 - registration authority, 494
 - repository, 494
 - Publicly available directory, 481–482
 - Purpose-built algorithms, 251
- Q**
- Quadratic polynomial, 467–468
 - Quantum computing, 456–457
 - Quantum safety, 460–462
 - Quantum-safe cryptography, 461
 - Qubits, 456
 - Quoted-printable transfer encodings, 606
- R**
- Radio-frequency identification (RFID), 442–443
 - antitheft, 443
 - counterfeit goods, 443
 - environmental logging, 443
 - privacy of electronic product code (EPC), 443
 - returns, 443
 - Radix, 230, 232
 - Rail fence cipher, 105
 - Random, scanning process, 694
 - Random delay, 307
 - Random numbers
 - generator, 212, 248
 - randomness, 246–247
 - independence, 246–247
 - uniform distribution, 246
 - unpredictability, 247
 - use of, 246–247
 - Randomization approach, 247
 - Randomness, 246–247
 - characteristics, 249
 - consistency, 249
 - frequency test, 250
 - independence, 246
 - Maurer’s universal statistical test, 250
 - runs test, 250
 - scalability, 249
 - tests, 250
 - uniform distribution, 246
 - uniformity, 249
 - Rapid elasticity, 702
 - RC4, 262–264
 - initialization of S, 262–263
 - stream generation, 263
 - strength of, 263–264
 - Read-only memory (ROM), 440
 - Realm, 519
 - Reflector DDoS, 692
 - Registration authority (RA), 494
 - Relatively prime, 47, 55, 142
 - Release of message contents, 27
 - Relying party (RP), 495, 503
 - Remote forwarding, 563
 - Remote user-authentication principles
 - challenge/response, 506
 - mutual authentication, 505–507
 - NIST model, 501–503
 - something the individual does (dynamic biometrics), 504
 - something the individual is (static biometrics), 504
 - something the individual knows, 504
 - something the individual possesses, 504
 - using asymmetric encryption
 - mutual authentication, 524–525
 - one-way authentication, 525–526
 - using symmetric encryption
 - mutual authentication, 507–510
 - Repetition Count Test, 276–277
 - Replay, 29
 - Replay attack, 506, 651
 - Replay protection, 740
 - Repudiation, 714
 - Reseed interval, 258, 259
 - Residue, 47, 81, 142, 155
 - Residue classes, 54, 82
 - Resource pooling, 702–703
 - Resource records (RRs), 619, 620
 - Reversible mapping, 115
 - RFC 4,706, 628–629
 - capabilities, 629
 - characteristics, 629
 - location, 630
 - RFC 5,342, 602
 - Rho step function, 370–371
 - Rijndael, 166, 168, 179, 186, 193, 195
 - Rings, 139–140
 - associativity of multiplication, 139
 - closure under multiplication, 139
 - commutativity of multiplication, 139
 - distributive laws, 139
 - integral domain, 140
 - multiplicative identity, 140
 - no zero divisors, 140
 - Rivest-Shamir-Adleman (RSA) algorithm, 288, 289, 296–309
 - computational aspects, 299–304
 - exponentiation in modular arithmetic, 300–301
 - key generation, 303–304
 - private key, 302–303
 - public key, 301–302
 - description of, 297–299
 - example of, 299
 - processing of multiple blocks, 300
 - security of, 304–309
 - CCA, 304, 308–309
 - factoring problem, 304–306
 - fault-based attack, 307–308
 - hardware fault-based attack, 304
 - mathematical attacks, 304
 - OAEP, 308–309
 - timing attacks, 304, 306–307
 - Robust Security Network (RSN), 581
 - Role-based access control (RBAC), 724
 - Round, 125, 126
 - constants in SHA-3, 373
 - function, 119, 121, 357–359
 - Routing control, 33
 - RRs. *See* Resource records (RRs)
 - RSA algorithm. *See* Rivest-Shamir-Adleman (RSA) algorithm
 - RSA-PSS digital signature algorithm
 - mask generation function, 430–431
 - signature verification, 433–435
 - signing operation, 431–433
 - RSN. *See* Robust Security Network (RSN)
 - Runs test, 250

S

- SaaS. *See* Software as a service (SaaS)
 - S-AES
 - arithmetic in GF(44), 785–786
 - data structures, 778
 - encryption and decryption
 - add key, 779
 - mix column, 781
 - nibble substitution, 779–781
 - shift row, 780–781
 - encryption round, 779
 - key expansion, 782
 - mix column function, 786–787
 - S-boxes, 780, 783
 - structure of, 783–785
 - transformations, 780
 - S-AES structure, 783–785
 - S-Box, 174, 175, 179, 780, 783
 - Scalability, 249
 - Schnorr digital signature scheme, 422–423
 - SecaaS. *See* Security as a service (SecaaS)
 - Second assertion, 70
 - Second preimage
 - attacks, 349
 - brute-force attacks, 349
 - Second preimage resistant, 347
 - Secret information, 26
 - Secret key, 84–85, 290
 - Secret-key encryption, 87
 - Secure Hash Algorithm (SHA), 352–361
 - Secure shell (SSH)
 - connection protocol, 560–564
 - transport layer security, 553–564
 - User Authentication Protocol, 558–559
 - Secure/Multipurpose Internet Mail Extension (S/MIME), 607, 609–619
 - certificate processing, 618
 - DANE, 624–625
 - enhanced security services, 618–619
 - secure mailing lists, 619
 - security labels, 618
 - signed receipts, 618
 - signing certificates, 619
 - messages, 614–618
 - certificates-only message, 618
 - clear signing, 617
 - compressedData, 614
 - envelopedData, 614, 615–616
 - registration request, 617
 - signedData, 614, 616
 - operational description, 610–613
 - authentication, 610–612
 - compression, 613
 - confidentiality, 611–612
 - email compatibility, 613
 - simplified functional flow, 612
 - user agent role, 618
- Security as a service (SecaaS), 721–722
- Security assessments, 723
- Security association database (SAD), 644, 645–646
 - AH information, 646
 - Anti-Replay Window, 646
 - ESP information, 646
 - IPsec Protocol Mode, 646
 - Lifetime of this Security Association, 646
 - Path MTU, 646
 - Sequence Counter Overflow, 646
 - Sequence Number Counter, 646
 - SPI, 645
- Security associations (SA), 645
 - authentication plus confidentiality, 658–659
 - ESP with authentication option, 658
 - transport adjacency, 658–659
 - transport-tunnel bundle, 659
 - combinations of, 659–660
 - IP destination address, 645
 - lifetime of, 646
 - payload, 666
 - attribute, 667
 - proposal, 667
 - transform, 667
- Security Protocol Identifier, 645
- SPI, 645
- Security assurance, 40
- Security attacks, 27–30
 - active attacks, 29–30
 - data modification, 30
 - denial of service, 29
 - masquerade, 29
 - replay, 29
 - passive attack, 27–29
 - release of message contents, 27
 - traffic analysis, 28
- Security awareness and training, 39
- Security considerations, 442–444
 - agricultural sensors, 443
 - automobiles, 444
 - home appliances, 443
 - industrial systems, 443–444
 - medical sensors, 443
 - RFID, 442–443
 - smart agricultural sensors, 443
- Security functionality, 40
- “Security in the Internet Architecture” (RFC 1636), 642
- Security information and event management (SIEM), 723
- Security label, 618
- Security mechanisms
 - access control, 33
 - authentication exchange, 33
 - cryptographic algorithms, 33
 - cryptographic hash functions, 346–348
 - collision resistant, 347
 - preimage resistant, 347
 - pseudorandomness, 348
 - second preimage resistant, 347
 - data integrity, 33
 - digital signature, 33
- ECB, 210
- MAC, 390–391
 - based on hash functions, 400
 - brute-force attacks, 390–391
 - computation resistance, 390
 - cryptanalysis, 391
- RSA algorithm, 304–309
 - brute force attacks, 304
 - CCA, 304, 308–309
 - factoring problem, 304–306
 - fault-based attack, 307–308
 - hardware fault-based attack, 304
 - mathematical attacks, 304
 - OAEP, 308–309
 - timing attacks, 304, 306–307
- services, 30–33
 - access control, 31
 - availability service, 32–33
 - data confidentiality, 31–32
 - data integrity, 32, 33
 - nonrepudiation, 32
- specific
 - access control, 33
 - authentication exchange, 33
 - data integrity, 33
 - digital signature, 33
 - notarization, 33
 - routing control, 33
 - traffic padding, 33
- Security Parameter Index (SPI), 645, 646
- Security policies and techniques, 737
- Security policy database (SPD), 644, 646–647
 - local and remote ports, 647
 - local IP address, 647
 - name, 647
 - next layer protocol, 647
 - remote IP address, 647
- Security protocols, 462
- Security Protocol Identifier, 645
- Security requirements, 445–448
 - AEAD, 446–447
 - side-channel attack, 446
- Security services
 - access control, 31
 - authentication, 31
 - availability service, 32–33
 - data confidentiality, 31–32
 - data integrity, 32
 - nonrepudiation, 32
- Security services (X.800), 30–33
- Security threats, 459
- Security updates, 734–735
- Seed, 248, 258
 - input to PRNG, 251
 - requirements, 250–251
- Seed length, 258
- Selective forgery, 420
- Selector field, 624
- Selectors, 646
- Sender Policy Framework (SPF), 607, 625–628
 - mechanisms, 627
 - modifiers, 627
 - operation, 628
 - on receiver side, 627–628
 - on sender side, 626
- Sensor/actuator technology, 729
- Sensors
 - IDS component, 682
 - IoT-enabled device component, 729–730
 - tamper detection, 736
- Sequence Counter Overflow, 646
- Sequence Number Counter, 646
- Sequence numbers, 523, 538, 605
- Server and client random, 538
- Server write key, 538
- Server write MAC secret, 538
- Service aggregation, 710
- Service arbitration, 710
- Service intermediation, 710
- Service provision security, 737
- Session identifier, 537
- Session key, 522, 611–612
- Set of residues, 54

- SHA. *See* Secure Hash Algorithm (SHA)
- SHA-0, 352
- SHA-1, 352
- SHA-2, 353
- SHA-3, 362–373
- iteration function *f*, 366–373
 - Chi step function, 372–373
 - composition, 367
 - constants in SHA-3, 373
 - Iota step function, 373
 - Pi step function, 371–372
 - Rho step function, 370–371
 - structure of, 367–368
 - theta step function, 368–370
 - parameters, 366
 - sponge construction, 362–366
 - absorbing phase, 364, 365
 - bitrate, 362
 - capacity, 364
 - iteration function, 362
 - multirate padding, 363
 - simple padding, 363
 - sponge function input and output, 363
 - squeezing phase, 365
 - state matrix, 367
 - step functions in, 368
- SHA-224, 353
- SHA-256, 353
- SHA-384, 353
- SHA-512, 353
- constants, 356
 - logic, 353–356
 - big-endian format, 355
 - step 1 append padding bits, 354
 - step 2 append length, 354
 - step 3 initialize hash buffer, 354–355
 - step 4 process message in 1024-bit (128-byte) blocks, 355–356
 - step 5 output, 356
 - message digest generation using, 354
 - round function, 357–361
- Shared technology vulnerabilities, 721
- ShiftRows, 171, 173, 194
- AES row and column operations, 180
 - forward shift row transformation, 179
 - inverse shift row transformation, 179
- Shor's factoring algorithm, 457–458
- Side-channel attack, 446
- SIEM. *See* Security information and event management (SIEM)
- Signal-hiding techniques, 569
- Signature verification
- decryption, 433
 - EM verification, 433–435
- Signing operation
- forming the signature, 433
 - message encoding, 431–433
- Simple Mail Transfer Protocol (SMTP), 599, 601
- Simple Network Management Protocol Version 3 (SNMPv3), 387
- Simple padding, 363
- Simple Mail Transfer Protocol (SMTP), 678
- Simplified AES (S-AES), 777–781. *See also* S-AES
- Single sign-on (SSO), 527
- Single-key algorithms, 34–35
- message authentication code, 35
 - symmetric encryption algorithms, 35
- Single-key encryption, 84, 87
- SipHash message authentication code, 455
- Skipjack, 740
- S/MIME. *See* Secure/Multipurpose Internet Mail Extension (S/MIME)
- SMTP. *See* Simple Mail Transfer Protocol (SMTP)
- Software as a service (SaaS), 703
- Sound/video input, 272
- SPD. *See* Security policy database (SPD)
- Special number field sieve (SNFS), 305
- Sponge construction, 362–366
- absorbing phase, 364, 365
 - bitrate, 362
 - capacity, 364
 - iteration function, 362
 - multirate padding, 363
 - simple padding, 363
 - sponge function input and output, 363
 - squeezing phase, 365
- Sponge function input and output, 363
- Spoofing identity, 714
- Squeezing phase, 364, 365
- Standards, 41–42
- Internet Society (ISOC), 41
 - National Institute of Standards and Technology (NIST), 41
- STARTTLS, 607, 624
- State, 168
- State array, 168
- State matrix, 367
- Stateful inspection firewalls, 678–679
- Static biometrics, 504
- Stream ciphers, 35, 87, 113–115, 260–262, 451
- advantage of, 261–262
 - design considerations for, 261
 - processes, 87
 - RC4, 262–264
 - initialization of S, 262–263
 - stream generation, 263
 - strength of, 263
 - using feedback shift registers, 264–272
 - Grain-128a, 269–272
 - linear, 265–268
 - nonlinear, 268–269
- Stream generation, 263
- Strict avalanche criterion (SAC), 130
- STRIDE threat model
- authorization, 715
 - availability, 714
 - confidentiality, 714
 - elevation of privilege, 714–715
 - information disclosure, 714
 - repudiation, 714
 - spoofing identity, 714
 - tampering with data, 714
- Strong encryption, 89
- SubBytes, 171, 174, 194
- Subject key identifier, 492
- Subkey, 119, 125, 523
- Subscriber, 503
- Substitute bytes, 171, 174–179
- AES byte-level operations, 174
 - construction of S-Box and IS-Box, 176
 - forward substitute byte transformation, 174
 - inverse substitute byte transformation, 178
- Substitution techniques, 90–104, 116, 117, 119
- Caesar cipher, 90–92
 - Hill cipher, 97–100
 - monoalphabetic ciphers, 92–95
 - one-time pad, 103–104
 - playfair cipher, 95–97
 - polyalphabetic ciphers, 100–103
- Substitution-permutation network (SPN), 119
- Superposition, 456–457
- Suplicants, 586
- Suppress-replay attacks, 509
- Symmetric block ciphers, 252
- Symmetric cipher model, 84–89
- ciphertext, 85
 - cryptanalysis and brute-force attack, 87–89
 - attacks on encrypted messages, 88
 - computationally secure encryption scheme, 89
 - cryptanalysis, 87
 - unconditionally secure encryption scheme, 89
 - cryptography
 - keys used, 87
 - plaintext, processed, 87
 - plaintext to ciphertext, 87
 - decryption algorithm, 85
 - encryption algorithm, 84
 - model of symmetric cryptosystem, 86
 - plaintext, 84
 - secret key, 84
 - secure use of conventional encryption, 85
 - simplified model of symmetric encryption, 85
- Symmetric cryptosystem, 86
- Symmetric encryption, 35, 84–89, 381–384
- external error control, 383
 - internal error control, 383
 - remote user-authentication using mutual authentication, 507–510
- Symmetric encryption algorithms, 35
- Symmetric key encryption, 87, 663
- System integrity, 24
- System vulnerabilities, 717
- ## T
- Tag, 388, 627, 635
- Tamper detection
- circuitry, 736
 - sensors, 736
 - switches, 736
- Tamper resistance, 736
- Tampering, 36
- TDEA. *See* Triple Data Encryption Algorithm (TDEA)
- Temporal Key Integrity Protocol (TKIP), 592–593
- Text type, 605
- TFC. *See* Traffic flow confidentiality (TFC)
- Theta step function, 368–370

- Third-party key distribution options, 476–477
- Threats, 27
 - mobile device security, 571–572
 - interaction with other systems, 572
 - lack of physical security controls, 571
 - location services, 572
 - by unknown parties, 572
 - untrusted content, 572
 - untrusted mobile devices, 571
 - untrusted networks, 572
 - wireless network security, 568–569
- Threshold detection, 685
- Ticket, 513
- Ticket-granting server (TGS), 513
- Ticket-granting service exchange, 523
- Time complexity, 293, 295
- Timestamp, 421, 477, 506
- Timing attacks, 304, 306–307
 - blinding, 307
 - constant exponentiation time, 307
 - DES, 129
 - random delay, 307
- TinyOS, 739
- TKIP. *See* Temporal Key Integrity Protocol (TKIP)
- TKIP sequence counter (TSC), 593
- Topological, scanning process, 694
- Total break, 420
- Traditional block cipher structure, 113–123
 - arbitrary reversible substitution cipher, 116
 - block cipher, 114–115
 - confusion, 118–119
 - diffusion, 118–119
 - encryption and decryption tables for substitution, 116
 - Feistel cipher, 117–123
 - block size, 120
 - ease of analysis, 121
 - fast software encryption/decryption, 121
 - key size, 121
 - number of rounds, 121
 - round function, 121
 - structure, 115–117, 119–121
 - subkey generation algorithm, 121
 - ideal block cipher, 115–117
 - motivation for Feistel cipher structure, 115–117
 - permutation, 117, 119
 - reversible or nonsingular, 115
 - round function, 119
 - SPN, 119
 - stream cipher, 113–115
 - substitution, 117, 119
- Traffic analysis, 28, 380
- Traffic flow confidentiality (TFC), 650
- Traffic padding, 33
- Traffic processing, IP security (IPsec), 648–649
 - inbound packets, 649
 - outbound packets, 648
- Traffic security, 574
- Traffic Selector payload, 667
- Traffic-flow confidentiality, 651
- Transceiver, 730
- Transfer encodings, 605–606
 - base64 transfer encoding, 606
 - quoted-printable, 606
- Transformation functions, AES, 174–184
 - AddRoundKey transformation
 - forward add round key transformation, 183
 - inputs for single AES round, 184
 - inverse add round key transformation, 183
 - MixColumns transformation, 180–183
 - forward mix column transformation, 180
 - inverse mix column transformation, 181
 - ShiftRows transformation
 - AES row and column operations, 180
 - forward shift row transformation, 179
 - inverse shift row transformation, 179
 - substitute bytes transformation, 174–179
 - AES byte-level operations, 174
 - construction of S-Box and IS-Box, 176
 - forward substitute byte transformation, 174
 - inverse substitute byte transformation, 178
- Transport layer protocol
 - host keys, 554–555
 - key generation, 558
 - packet exchange, 554–558
 - algorithm negotiation, 555
 - key exchange, 556
 - message authentication code, 554
 - packet length, 554
 - padding length, 554
 - payload, 554
 - random padding, 554
- Transport Layer Security (TLS), 533–564
 - alert protocol, 541
 - architecture, 536–538
 - cipher spec, 538
 - compression method, 538
 - connection, 537
 - is resumable, 538
 - master secret, 538
 - peer certificate, 537
 - session, 537
 - session identifier, 537
 - attacks
 - categories, 550–551
 - TLSv1.3, 551
 - Change Cipher Spec protocol, 540
 - connection state
 - client write key, 538
 - client write MAC secret, 538
 - initialization vectors, 538
 - sequence numbers, 538
 - server and client random, 538
 - server write key, 538
 - server write MAC secret, 538
 - cryptographic computations, 547–549
 - generation, 548
 - master secret creation, 547
 - handshake protocol, 541–547
 - HTTPS, 551–552
 - connection closure, 552
 - connection initiation, 552
 - message authentication code, 554
 - padding, 554
 - pseudorandom function, 548–549
 - record protocol, 538–540
 - compressed length (16 bits), 540
 - compression, 538–539
 - confidentiality, 538
 - content type (8 bits), 540
 - fragmentation, 538
 - MAC, 540
 - major version (8 bits), 540
 - message integrity, 538
 - minor version (8 bits), 540
 - secure shell, 553–564
 - connection protocol, 560–564
 - transport layer protocol, 553, 554–558
 - user authentication protocol, 558
 - session state
 - Cipher spec, 538
 - compression method, 538
 - is resumable, 538
 - master secret, 538
 - peer certificate, 537
 - session identifier, 537
 - web security considerations, 534–536
- Transport modes, 652–654
- Transposition cipher, 105
- Trap-door one-way function, 295
- Triple Data Encryption Algorithm (TDEA), 118
- Triple Data Encryption Standard (3DES)
 - known-plaintext attack on, 206
 - with three keys, 207
 - with two keys, 204–207
- Trojan horse, 687
- True random number generator (TRNG), 247–248, 272–280
 - block cipher, 276
 - entropy sources, 273–274
 - disk drives, 273–274
 - sound/video input, 273
 - hash function, 274–275
 - health testing, 276–278
 - on conditioning function, 278
 - on noise source, 276–278
 - Intel digital random number generator, 277–280
 - hardware architecture, 278–279
 - logical structure, 279–280
 - PRNGs vs., 274
- Trust
 - concepts, 37
 - direct historical, 41
 - mandated, 41
 - mediated, 41
 - model, 38–39
 - and information security, 38–40
 - risk, 38
 - trustworthiness, 38
 - propensity to, 38
 - relationships, 40–41
 - validated, 41

- Trust relationship, 40–41
 - Trustworthiness, 38
 - ability, 38
 - benevolence, 38
 - of individual, 39–40
 - human resource security, 39
 - security awareness and training, 39
 - of information systems, 40
 - security assurance, 40
 - security functionality, 40
 - integrity, 38
 - of organization, 40
 - TSC. *See* TKIP sequence counter (TSC)
 - Tunnel modes, 560, 652–657
 - Tweakable block ciphers, 219–220
 - Two simple hash function, 344–346
 - Two-key algorithms, 34–36
 - asymmetric encryption algorithms, 35
 - digital signature algorithm, 36
 - key exchange, 36
 - user authentication, 36
- U**
- Unconditionally secure encryption scheme, 89
 - Uniform distribution, 246
 - Uniformity, 249
 - Universal forgery, 420
 - Unpredictability, 247
 - backward, 250
 - forward, 250
 - Update function, 259–260
 - U.S. National Security Agency (NSA), 459, 740
 - User authentication, 36
 - and access control, 739
 - federated identity management
 - identity federation, 528–530
 - identity management, 526–528
 - Kerberos, 510–524
 - motivation, 511–512
 - Version 4, 512–520
 - Version 5, 521–524
 - remote user-authentication
 - principles
 - mutual authentication, 505–507
 - NIST model, 501–503
 - something the individual does (dynamic biometrics), 504
 - something the individual is (static biometrics), 504
 - something the individual knows, 504
 - something the individual possesses, 504
 - using asymmetric encryption
 - mutual authentication, 524–525
 - one-way authentication, 525–526
 - using symmetric encryption
 - mutual authentication, 507–510
 - User Authentication Protocol
 - authentication methods, 559
 - message exchange, 559
 - message types and formats, 558–559
 - User interface, 682
- V**
- Validated trust, 41
 - Vendor ID payload, 667
 - Verifier, 502
 - Vernam cipher, 102–103
 - Vigenère cipher, 100–102
 - Virtual private networks (VPNs), 574, 655
 - Virus detection, 344
 - Viruses, 687
- W**
- WAN. *See* Wide area network (WAN)
 - Weak collision resistant, 347
 - Web security, 723
 - considerations, 534–536
 - threats, 535
 - traffic security approaches, 535–536
 - Weierstrass equation, 324
 - WEP. *See* Wired Equivalent Privacy (WEP)
 - Wide area network (WAN), 680
 - Wi-Fi, 575
 - Wi-Fi Protected Access (WPA), 575, 581
 - Wired Equivalent Privacy (WEP), 581, 592
 - Wireless network security, 567–594
 - components, 568
 - 02.11 wireless LAN, 574–580
 - association-related services, 579–580
 - MPDU format, 577
 - network components and architectural model, 574–578
 - protocol architecture, 575–577
 - services, 578–580
 - terminology, 575
 - Wi-Fi alliance, 575
 - IEEE 802.11i wireless LAN security, 580–594
 - authentication phase, 586–588
 - discovery phase, 584–586
 - elements of, 582
 - key management phase, 588–592
 - phases of operation, 581–584
 - protected data transfer phase, 592–593
 - pseudorandom function, 593–594
 - services, 581
 - measures, 569–570
 - securing wireless access points, 569
 - securing wireless networks, 570
 - securing wireless transmissions, 569
 - mobile device security, 570–574
 - strategy, 572–574
 - threats, 571–572
 - threats, 568–569
 - wireless security, 567–570
 - Worms, 687
 - WPA. *See* Wi-Fi Protected Access (WPA)
- X**
- X.509 certificates, 485–493
 - certificate subject and issuer attributes
 - issuer alternative name, 493
 - subject alternative name, 493
 - subject directory attributes, 493
 - certification authority
 - forward certificates, 490
 - reverse certificates, 490
 - certification path constraints
 - basic constraints, 493
 - name constraints, 493
 - policy constraints, 493
 - formats
 - extensions, 488
 - issuer name, 487
 - issuer unique identifier, 488
 - period of validity, 488
 - serial number, 487
 - signature, 488
 - signature algorithm identifier, 487
 - subject name, 488
 - subject unique identifier, 488
 - subject's public-key information, 488
 - version, 487
 - hierarchy, 490
 - key and policy information, 492–493
 - authority key identifier, 492
 - certificate policies, 493
 - key usage, 492–493
 - policy mappings, 493
 - private-key usage period, 493
 - subject key identifier, 492
 - revocation of, 491
 - user's, 489–491
 - Version 3, 491–492
 - XTS-AES mode, 218–225
 - ciphertext-stealing technique, 223
 - definition, 224
 - feedback characteristic of modes of operation, 219
 - operation on sector, 223–225
 - operation on single block, 221–223
 - storage encryption requirements, 220–221
 - tweakable block ciphers, 219–220
- Z**
- Zero point, 324
 - ZIP, 92

ACRONYMS

3DES	Triple DES	IV	Initialization Vector
AES	Advanced Encryption Standard	KDC	Key Distribution Center
AH	Authentication Header	LAN	Local Area Network
ANSI	American National Standards Institute	MAC	Message Authentication Code
CBC	Cipher Block Chaining	MD5	Message Digest, Version 5
CC	Common Criteria	MIC	Message Integrity Code
CESG	Communications-Electronics Security Group	MIME	Multipurpose Internet Mail Extension
CFB	Cipher Feedback	MTU	Maximum Transmission Unit
CMAC	Cipher-Based Message Authentication Code	NIST	National Institute of Standards and Technology
CRT	Chinese Remainder Theorem	NSA	National Security Agency
DDoS	Distributed Denial of Service	OFB	Output Feedback
DEA	Data Encryption Algorithm	PCBC	Propagating Cipher Block Chaining
DES	Data Encryption Standard	PGP	Pretty Good Privacy
DoS	Denial of Service	PIV	Personal Identity Verification
DSA	Digital Signature Algorithm	PKI	Public Key Infrastructure
DSS	Digital Signature Standard	PRNG	Pseudorandom Number Generator
ECB	Electronic Codebook	RFC	Request for Comments
ECC	Elliptic Curve Cryptography	RNG	Random Number Generator
ECDSA	Elliptic Curve Digital Signature Algorithm	RSA	Rivest–Shamir–Adelman
ESP	Encapsulating Security Payload	RSA-PSS	RSA Probabilistic Signature Scheme
FIPS	Federal Information Processing Standard	SET	Secure Electronic Transaction
IAB	Internet Architecture Board	SHA	Secure Hash Algorithm
IETF	Internet Engineering Task Force	SHS	Secure Hash Standard
IP	Internet Protocol	S/MIME	Secure MIME
IPsec	IP Security	SNMP	Simple Network Management Protocol
ISO	International Organization for Standardization	SNMPv3	Simple Network Management Protocol Version 3
ITU	International Telecommunication Union	SSL	Secure Sockets Layer
ITU-T	ITU Telecommunication Standardization Sector	TCP	Transmission Control Protocol
		TDEA	Triple DEA
		TLS	Transport Layer Security
		UDP	User Datagram Protocol
		WAN	Wide Area Network